

DOCUMENT RESUME

ED 226 239

CE 035 201

TITLE Apprentice Heating Systems Specialist, 11-1. Military Curriculum Materials for Vocational and Technical Education.

INSTITUTION Air Force School of Applied Aerospace Sciences, Sheppard AFB, Tex.; Ohio State Univ., Columbus. National Center for Research in Vocational Education.

SPONS AGENCY Office of Education (DHEW), Washington, D.C.

PUB DATE 78

NOTE 548p.

PUB TYPE Guides - Classroom Use - Materials (For Learner) (051)

EDRS PRICE MF02/PC22 Plus Postage.

DESCRIPTORS Behavioral Objectives; Blueprints; Criterion Referenced Tests; *Electrical Appliances; Electricity; Electronic Control; *Equipment Maintenance; *Equipment Utilization; *Fuels; Hand Tools; *Heating; Job Skills; Military Personnel; Military Training; Postsecondary Education; Safety; Secondary Education; *Technical Education; Temperature; Water Treatment

IDENTIFIERS Military Curriculum Project; Power Plants

ABSTRACT This military-developed text consists of four volumes of materials for use by those studying to become apprentice heating system specialists. Covered in the individual volumes are the following topics: related subjects (basic electricity, electrical controls, pipe and copper tubing, the principles of heating, fuels, and fuel systems); heating systems (space heating-unit heaters as well as burner, warm-air, and hot-water heating); and central heat plants (high temperature water, steamplant operation, steamplant maintenance, and external and internal water treatment). Each chapter is organized around criterion learning objectives with readings, criterion test items, and answers. The volume review is also keyed to the objectives, but no answers are provided. (MN)

 * Reproductions supplied by EDRS are the best that can be made *
 * from the original document. *

MILITARY CURRICULUM MATERIALS

9
The military-developed curriculum materials in this course package were selected by the National Center for Research in Vocational Education Military Curriculum Project for dissemination to the six regional Curriculum Coordination Centers and other instructional materials agencies. The purpose of disseminating these courses was to make curriculum materials developed by the military more accessible to vocational educators in the civilian setting.

The course materials were acquired, evaluated by project staff and practitioners in the field, and prepared for dissemination. Materials which were specific to the military were deleted, copyrighted materials were either omitted or approval for their use was obtained. These course packages contain curriculum resource materials which can be adapted to support vocational instruction and curriculum development.

The National Center Mission Statement

The National Center for Research in Vocational Education's mission is to increase the ability of diverse agencies, institutions, and organizations to solve educational problems relating to individual career planning, preparation, and progression. The National Center fulfills its mission by:

- Generating knowledge through research
- Developing educational programs and products
- Evaluating individual program needs and outcomes
- Installing educational programs and products
- Operating information systems and services
- Conducting leadership development and training programs

FOR FURTHER INFORMATION ABOUT Military Curriculum Materials

WRITE OR CALL

Program Information Office
The National Center for Research in Vocational
Education
The Ohio State University
1960 Kenny Road, Columbus, Ohio 43210
Telephone: 614/486-3655 or Toll Free 800/
848-4815 within the continental U.S.
(except Ohio)



THE NATIONAL CENTER
FOR RESEARCH IN VOCATIONAL EDUCATION
The Ohio State University, 1960 Kenny Road, Columbus, Ohio 43210
Tel. (614) 486-3655
Center: C1VOCED050/Columbus, Ohio

Military Curriculum Materials for Vocational and Technical Education

Information and Field
Services Division

The National Center for Research
in Vocational Education



Military Curriculum Materials Dissemination Is . . .

an activity to increase the accessibility of military-developed curriculum materials to vocational and technical educators.

This project, funded by the U.S. Office of Education, includes the identification and acquisition of curriculum materials in print form from the Coast Guard, Air Force, Army, Marine Corps and Navy.

Access to military curriculum materials is provided through a "Joint Memorandum of Understanding" between the U.S. Office of Education and the Department of Defense.

The acquired materials are reviewed by staff and subject matter specialists, and courses deemed applicable to vocational and technical education are selected for dissemination.

The National Center for Research in Vocational Education is the U.S. Office of Education's designated representative to acquire the materials and conduct the project activities.

Project Staff:

Wesley E. Budke, Ph.D., Director
National Center Clearinghouse

Shirley A. Chase, Ph.D.
Project Director

What Materials Are Available?

One hundred twenty courses on microfiche (thirteen in paper form) and descriptions of each have been provided to the vocational Curriculum Coordination Centers and other instructional materials agencies for dissemination.

Course materials include programmed instruction, curriculum outlines, instructor guides, student workbooks and technical manuals.

The 120 courses represent the following sixteen vocational subject areas:

Agriculture	Food Service
Aviation	Health
Building & Construction	Heating & Air Conditioning
Trades	Machine Shop Management & Supervision
Clerical Occupations	Meteorology & Navigation
Communications	Photography
Drafting	Public Service
Electronics	
Engine Mechanics	

The number of courses and the subject areas represented will expand as additional materials with application to vocational and technical education are identified and selected for dissemination.

How Can These Materials Be Obtained?

Contact the Curriculum Coordination Center in your region for information on obtaining materials (e.g., availability and cost). They will respond to your request directly or refer you to an instructional materials agency closer to you.

CURRICULUM COORDINATION CENTERS

EAST CENTRAL
Rebecca S. Douglass
Director
100 North First Street
Springfield, IL 62777
217/782-0759

NORTHWEST
William Daniels
Director
Building 17
Airdustrial Park
Olympia, WA 98504
206/753-0879

MIDWEST
Robert Patton
Director
1515 West Sixth Ave.
Stillwater, OK 74704
405/377-2000

SOUTHEAST
James F. Shill, Ph.D.
Director
Mississippi State University
Drawer DX
Mississippi State, MS 39762
601/325-2510

NORTHEAST
Joseph F. Kelly, Ph.D.
Director
225 West State Street
Trenton, NJ 08625
609/292-6562

WESTERN
Lawrence F. H. Zane, Ph.D.
Director
1776 University Ave.
Honolulu, HI 96822
808/948-7834

APPRENTICE HEATING SYSTEMS SPECIALIST

Table of Contents

Course Description	Page 1
Volume 1 - <u>Related Subjects</u> - Text Material	Page 3
Volume Review Exercise	Page 56
Volume 2 - <u>Fundamentals</u> - Text Material	Page 63
Volume Review Exercise	Page 209
Volume 3 - <u>Heating Systems</u> - Text Material	Page 220
Volume Review Exercise	Page 322
Volume 4 - <u>Central Heat Plants</u> - Text Material	Page 333
Volume Review Exercise	Page 524

Developed by:
United States Air Force

Occupational Area:
Heating and Air Conditioning

Development and Review Dates:
Unknown

Cost: **Print Pages:**
534

Availability:
Military Curriculum Project, The Center for Vocational Education, 1960 Kenny Rd., Columbus, OH 43210

Suggested Background:

None

Target Audiences:

Grades 10-adult

Organization of Materials:

Objectives, readings, criterion test items, answers; volume review exercises

Type of Instruction:

Individualized, self-paced

Type of Materials:	No. of Pages:	Average Completion Time:
Volume 1 - <i>Related Subjects</i>	50	Flexible
Volume Review Exercise	7	
Volume 2 - <i>Fundamentals</i>	142	Flexible
Volume Review Exercise	11	
Volume 3 - <i>Heating Systems</i>	98	Flexible
Volume Review Exercise	11	
Volume 4 - <i>Central Heat Plants</i>	187	Flexible
Volume Review Exercise	14	

Supplementary Materials Required:

None

Course Description

This course was designed to provide information for Apprentice (semi-skilled) workers in the heating systems trade. The duties of the *Apprentice Heating Systems Specialist* are as follows:

- Installs and maintains heating system components and equipment
- Operates and maintains central heating plants
- Maintains and repairs building heating systems
- Maintains tools and equipment

The course is divided into four volumes covering the fundamentals of heating systems and heating plants. Some sections were deleted because they referred to specific military organization or operations,

- Volume 1 - *Related Subjects* contains four chapters. The chapter on prints and tools and part of another chapter on safety are covered. The other sections were not suitable for inclusion.
- Volume 2 - *Fundamentals* contains five chapters covering basic electricity, electrical controls, pipe and copper tubing, the principles of heating, and fuels and fuel systems.
- Volume 3 - *Heating Systems* contains four chapters discussing space heating-unit heaters, and burner, warm-air, and hot-water heating.
- Volume 4 - *Central Heat Plants* contains five chapters covering high temperature water, steamplant operation, steamplant maintenance, and external and internal water treatment.

Each chapter is organized around criterion learning objectives with readings, criterion test items, and answers. The volume review is also keyed to the objectives but no answers are available. The course is designed for self-study and evaluation but would best be used in a laboratory or on-the-job learning situation.

54730 01 7409

3

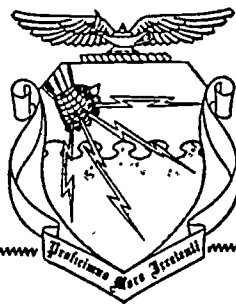
CDC 54730

APPRENTICE HEATING SYSTEMS SPECIALIST

(AFSCs 54730 and 54730A)

Volume 1

Related Subjects



Extension Course Institute

Air University

11

4



PREPARED BY
DEPARTMENT OF CIVIL ENGINEERING TRAINING
SCHOOL OF APPLIED AEROSPACE SCIENCES (ATC)
SHEPPARD AIR FORCE BASE, TEXAS

EXTENSION COURSE INSTITUTE, GUNTER AIR FORCE STATION, ALABAMA

THIS PUBLICATION HAS BEEN REVIEWED AND APPROVED BY COMPETENT PERSONNEL
OF THE PREPARING COMMAND IN ACCORDANCE WITH CURRENT DIRECTIVES
ON DOCTRINE, POLICY, ESSENTIALITY, PROPRIETY, AND QUALITY.

Preface

THE AIR FORCE realizes that its buildings must be provided with heating systems so that people can work efficiently and live comfortably. The civil engineer at each Air Force installation has been delegated to provide this necessary heating. He must also furnish processing steam for hospital sterilization work and cooking, for the operation of food steamtables in kitchens and dining rooms, for aircraft and automotive cleaning equipment, for clothes (cleaning and pressing apparatus), and for specialized processing that may be required.

Each year the Air Force uses amazing amounts of solid, liquid, and gaseous fuels for heating. The cost of consuming these fuels in heating units amounts to many millions of dollars. It is therefore obvious that heating alone is a very large business of the Air Force. For this reason, the efficient operation of the base heating systems is an important factor in reducing the overall cost of base operation. Because of this magnitude, even small increases in efficiency can result in big savings.

Too often inefficiency results (1) from using poor firing methods, (2) from inadequate furnace and boiler maintenance, (3) from failure to choose the best fuel for the equipment installed, (4) from improper design, and (5) from improper installation of heating equipment. The most prevalent of these are poor firing methods and inadequate preventive maintenance of stokers, furnaces, and boilers. If proper operating and maintenance practices are strictly observed by personnel, the cost of heating can be greatly decreased.

This is the first volume of this course and it contains discussions on subjects designed to introduce you to the career field of heating. You will also study about security and safety, publications, and prints and tools.

Code numbers appearing on figures are for preparing agency identification only.

If you have questions on the accuracy or currency of the subject matter of this text, or recommendations for its improvement, send them to Tech Tng Cen/TTOC, Sheppard AFB TX 76311.

If you have questions on course enrollment or administration, or on any of ECI's instructional aids (your key to Career Development, Behavioral Objective Exercises, Volume Review Exercise, and Course Examination), consult your education officer, training officer, or NCO, as appropriate. If he can't answer your questions, send them to ECI, Gunter AFS AL 36118, preferably on ECI Form 17, Student Request for Assistance.

This volume is valued at 18 hours (6 points).

Material in this volume is technically accurate, adequate, and current as of April 1974.

6

Contents

	<i>Page</i>
<i>Preface</i>	<i>iii</i>
Chapter	
1 <i>Civil Engineering</i>	1
2 <i>Security and Safety</i>	16
3 <i>Publications</i>	35
4 <i>Prints and Tools</i>	55
<i>Bibliography</i>	84
<i>Answers for Exercises</i>	85

14

7

MODIFICATIONS

Pages 1-22 of this publication has (have) been deleted in adapting this material for inclusion in the "Trial Implementation of a Model System to Provide Military Curriculum Materials for Use in Vocational and Technical Education." Deleted material involves extensive use of military forms, procedures, systems, etc. and was not considered appropriate for use in vocational and technical education.

8

conditions. This will aid your supervisor in accomplishing his responsibility, plus assuring you of safe working conditions.

Your work area may contain many potential hazards if you fail to follow the safety rules established for your protection. The following paragraphs will make you conscious of some of the things you should, or shouldn't do, to perform your job safely.

Housekeeping. Poor housekeeping, that is, not keeping your work area clean and orderly, can result in various types of accidents both of a major and minor nature. Broken bones, cuts, gouges, bruises, burns, and many other injuries can result from poor housekeeping. You can help prevent these injuries to yourself and others simply by practicing good housekeeping. Some of the important items to consider in keeping your working area, and also your living area, in proper order are given below.

- Keep all floors and walkways clean, dry, and free from spilled oil, fuel, or other contaminants. If fuel, oil, or grease is spilled, clean it up immediately. Slipping and falling could result in a serious injury to you or someone else.

- Insure that your plant or other area is adequately ventilated at all times. Vapors from fuels, oils, greases, and various types of acids are injurious to your health.

- Keep all working areas well lighted if at all possible. You cannot work efficiently and safely without sufficient lighting. Check the lighting system frequently and replace burned out lamps, fuses, and accomplish other preventive maintenance as required.

- Don't leave tools scattered about on floors, engines, workstands, or any other place other than those cabinets and boxes especially provided for tools. Some tools used in maintenance are heavy enough to cause considerable damage by falling a short distance.

- Don't struggle with a toolbox which is too heavy to handle conveniently. Men have been known to rupture themselves in handling excessively heavy toolboxes. Divide your tools so that you can handle them without strain.

- Don't clutter your work area with unnecessary equipment. If you do not intend to use an item, store it in a safe place.

- Keep all ropes, chains, cables, hoses, and electrical extension cords properly stowed when not in use.

- Provide suitable waste containers for waste and insure that waste is promptly put into the proper container. Mark each container for the material it is to be used for.

2-3. Principles of Ground Safety

As an Air Force specialist, you should have two primary aims in life: one, to do a first-class job in your assigned duty; the other, to return to civilian life, either by discharge or retirement, in as good a physical condition as possible. A thorough knowledge of the hazards confronting you, the established safety rules to protect you, and your observance of these safety rules, may determine what condition you will be in when you return to civilian life. In fact, it could determine whether or not you live long enough to become a civilian again.

Most accidents can be prevented if everyone cooperates to eliminate unsafe acts and conditions. Accidents do not happen because of unchangeable circumstances or because of fate. They happen because there is ignorance or misunderstanding of what constitutes a hazard or indifference to existing hazards. The following paragraphs provide you with vital information on safety, and accident causes. Safety is a tool that you cannot afford to be without.

024. List the safety habits that heating specialists should practice.

You, as an apprentice heating systems specialist, should be concerned with:

a. Safe working conditions.

b. The types and use of protective equipment.

c. Knowing the proper use and maintenance of your tools.

d. Knowing the fundamentals of first aid, including artificial respiration.

Although your supervisor is responsible for insuring that all aspects of a safe surrounding is maintained, you should take it upon yourself to be aware of any unsafe

• Use extra care in disposing of scrap metal, tubing, wire, glass, etc. Insure that all parts of the materials are well inside the waste container. The sharp edges of these materials will cut and tear your skin as well as your clothes.

• Maintain an adequate inspection program of all electrical cables, switchgear, and equipment for frayed wiring insulation, exposed contacts, and condition of switch handles and other controls.

• Inspect your shop frequently for protruding nails, bolt ends, and other sharp points which may cause injury. Also insure that broken window and door glasses are replaced promptly and the broken glass properly disposed of.

• Insure that water fountains, lunch areas, and personnel clothing lockers are kept in a clean, sanitary condition. Illness caused by contaminated water, food, coffee, etc., can often become more serious than most accidents.

The above listed housekeeping items are not the only things for you to consider, but they will help you improve your housekeeping situation.

Horseplay. Some of the common varieties of horseplay are pushing, tripping, directing compressed air toward a friend, shocking a friend with electricity, applying the hotfoot, and, perhaps the worst of all, "goosing." This goosing, if applied to a nervous person, may cause him to leap into moving machinery or into contact with high voltage electricity, or he may simply fall and "only" break an arm. Injuries or deaths resulting from horseplay cannot be justified. Horseplay in any Air Force shop is strictly forbidden.

Improper Working Methods. Equipment which has exposed moving parts such as belts, chains, flywheels, moving arms, etc., can be serious safety hazard unless care is exercised during its operation and maintenance. While most moving parts of machinery are inclosed in protective guards of one kind or another, alertness on the part of the operator or mechanic is essential. Gloves, neckties, or loose clothing, particularly large loose sleeves, should not be worn around moving machinery. Just stop for a moment and visualize what would happen if your necktie or even your sleeve should become caught in a drive belt or chain. You would be lucky to escape with your life.

Any adjustment, cleaning, lubrication, or repair of moving machinery should be accomplished with the device stopped if at all

possible. If it is not possible to stop the device, extreme care should, and must, be observed to prevent serious injury.

Exercises (024):

1. Insuring that your plant is adequately ventilated is a form of what safety habit?
2. List five practices that are considered good working habits.
3. Explain why the act of "goosing" is considered an unsafe act.
4. List five habits that are considered unsafe acts.

025. Cite the objectives of ground safety.

To reduce accidents throughout the Air Force, a ground safety section has been established at each Air Force base. This ground safety section has a well-established safety program in effect at all times. You should carry out to the fullest extent possible all safety policies and procedures. This includes both those of the ground safety section and those of your local shop. Be sure that you include any directives passed on to you through safety meetings. The ground safety program is based on the fact that most accidents can be prevented, before they happen! When safety is conscientiously practiced, injury to personnel and equipment will be at a minimum.

Exercises (025):

1. Cite the main objectives of ground safety.

026. Identify the safety directives applicable to a heating system specialist.

There are certain safety directives that you, as a heating specialist, should become familiar

with. They should be readily available for you to locate information that pertains to different portions of your duties.

(1) *Industrial Safety Accident Prevention Handbook* (AFM 127-101). The purpose of this manual is to inform people of the general requirements of ground safety. The responsibility for safety at all levels of activity is clearly outlined. To aid the various activities in meeting their responsibilities, the manual identifies all known safety hazards. It includes the principles of shop safety, health hazards and protection, fire prevention, aerospace safety, and other areas not so closely related to your field. One chapter in the manual is devoted entirely to safety rules pertaining to electrical facilities and equipment.

(2) *Electrical Facilities Safe Practices Handbook* (AFP 85-1). This pamphlet is in a size (pocket size) and format so that you can easily have it available for ready reference on the job.

Unlike the *Industrial Safety Accident Prevention Handbook*, which gives you general requirements, AFP 85-1 prescribes specific safe practices and procedures for people maintaining and operating electrical systems and equipment. In other words, the pamphlet is written especially for people who work around electricity. Safe working practices, protective clothing and equipment, grounding electric tools, and first aid procedures are but a few of the important items covered in the pamphlet. These two important safety publications are not the only directives that you should acquaint yourself with. Others which hold an equal amount of importance are safety posters. These posters are displayed on safety bulletin boards throughout your organization. They are changed periodically to enhance an interest from all personnel. The poster subjects are based on current ideas and/or events. There are also safety circulators which are routed through each section. Safety memorandum and thoughts are again based on current events and incidents.

Safety briefings could be classified as safety directives. Each section holds safety briefings at least on a weekly basis. Section supervisors also give safety orientation briefings to all new airmen. These assure that all personnel become acquainted with hazards in their respective work areas.

Exercises (026):

1. Which Air Force safety directive would be most available to you while working on the job?

2. Which form of safety directive would a newly assigned individual expect to be subjected to?

3. Which AF directive informs personnel of the general requirements of ground safety?

2-4. First Aid Procedures

Someday you may save someone's life, possibly your own, if you know how to render first aid properly. As you know, first aid refers to the treatment given the sick or injured before regular medical or surgical treatment can be administered by trained personnel. The fundamentals of first aid are easily learned. You can improve your handling of emergencies just by acquainting yourself with the contents of this section. Although the information presented under the following learning objectives is not intended to qualify you as a doctor or even a medical aid man, it may help you save a life.

027. State the first aid procedures you would use in given situations.

There are many types of injuries. Some of the more common injuries and the emergency first aid for them are discussed in the following paragraphs.

Wounds. The three lifesaving steps are: stop the bleeding, prevent shock, and protect the wound.

First apply pressure to the wound with a dressing or any clean article of cloth. The dressing is placed against the wound and firm pressure should be applied as long as needed. If the wound is on an arm or leg, and if bleeding continues, place the patient in a prone position with the injured limb raised. The limbs should not be raised if broken bones are suspected.

If blood is gushing from the wound and the previously discussed methods of stopping the bleeding have failed, a tourniquet should be applied. The tourniquet should be tightened only enough to stop arterial bleeding (gushing of blood from the wound). Always place the tourniquet between the wound and the heart, in most cases just above the wound; however, in case of bleeding below the knee or elbow, a tourniquet should be placed above these joints.



Figure 2-1. Pressure points for bleeding control.

The patient should be seen by a medical officer as soon as possible after the tourniquet is applied. The tourniquet should not be loosened by anyone except trained medical personnel.

Bleeding can often be reduced or stopped by applying hand or finger pressure at various points on a patient's body as indicated in figure 2-1.

The pressure points in the groin and neck are particularly important. If the wound is too high on the leg for a tourniquet to be applied, the pressure points in the groin can be used. A neck pressure point should be used when the patient has a profusely bleeding scalp wound. Use the neck pressure point only when other methods of stopping the bleeding have failed. Do not apply pressure to both neck points at the same time or the blood supply to the brain will be critically reduced.

Prevent or Treat Shock. Treatment for shock is started as soon as you come upon a casualty. Shock is a condition of great weakness of the body. It can, and often does, result in death, and may be caused by any type of injury. The more severe the injury, the more likely the occurrence of shock.

A person in shock may tremble and appear nervous. His pulse becomes rapid and weak. He may be excessively thirsty. He may become quite pale and wet with perspiration. He may gasp for air, and he may pass out.

A person may not go into shock for sometime after an injury; therefore, he should be treated for shock whether he has shock symptoms or not. To prevent or treat shock, make the patient comfortable. Remove any bulky items the patient has been carrying. Loosen his belt and clothes. Handle him gently. Do not move him more than is absolutely necessary. If he is lying in an abnormal position, make sure no bones are broken before you attempt to straighten him out. If there is no head wound, lower his head and shoulders, or if possible, raise his legs to increase the flow of blood to the brain. Patients with head wounds are treated as described in the section covering head wounds. Use a blanket, coat, etc., to keep him from becoming chilled. Be sure to put something under him to protect him from the cold ground. If he is unconscious, place him face down with his head turned to one side. This position helps to prevent choking should he vomit. Once you have the patient in the proper position, don't move him because to do so might make his blood pressure drop.

12
If the patient remains conscious, replace body fluid by giving him coffee, cocoa, or tea to drink. Do not give fluids to a patient who is unconscious or to one with a stomach wound. In some cases it may be advisable to apply breathing oxygen if available.

Protect the Wound. A dressing held in place by a bandage helps protect the wound from germs; foreign matter, and further injury. Keep your hands off the wound and do not touch the side of the dressing that goes next to the wound. Don't pull clothing over the area to be treated; tear or cut clothing away from the wound.

To treat a belly wound, cover it with a sterile dressing from a first aid pack or kit, fasten the dressing securely and treat the patient for shock. Do not try to replace organs such as intestines, protruding from the belly. To do so might cause infection and severe shock. However, if it is necessary to move an exposed intestine in order to cover the wound then do so. Be sure to keep the intestines wet with water. Do not give food or water through the mouth but the person's lips may be moistened with a wet cloth.

Chest wounds are particularly dangerous if air is being sucked in and blown out of the chest cavity through the wound. When such condition exists, the wound itself is not as dangerous as the air which goes through it because the air squeezes the lung, and may cause it to collapse. Make a chest wound airtight as soon as possible. The victim's life may depend on it. To make the wound airtight, have the patient forcibly exhale, if possible. Immediately apply a dressing which is large enough to stop the flow of air through the wound. Pack the dressing firmly over the wound. Cover the dressing with a large piece of material, such as from a waterproof garment to help make the wound airtight. Bind this covering securely with a belt or strips of torn clothing. Encourage the patient to lie on his injured side so that the lung of his uninjured side can receive more air.

Head wounds may consist of one of the following conditions or a combination of these conditions; a cut or bruise of the scalp, fracture of the skull, or an injury to the blood vessels to the scalp, skull, and brain. A scalp wound is easily detected because of the profuse bleeding. To treat such a wound, perform the three lifesaver steps described above. Once dressing is applied, do not remove it.

In any head injury do not place the patient's head in a position lower than the rest of his body. Keep him flat on his back unless he is unconscious or unless the wound

is on the back of his head. If the patient is unconscious, examine the mouth for false teeth or other objects which might cause choking. Place him face down with head turned to one side.

Bleeding from the neck usually is severe because of the many blood vessels in this area. Stop the bleeding by exerting pressure with a sterile dressing. Then bind the dressing so as to protect the wound. If the large artery, or vein is cut, apply hand pressure both above and below the cut. A patient with a penetrating neck wound needs special treatment to prevent him from choking on blood. Have him lean forward with his head held forward and down or have him lie face down. These positions allow the blood to drain out of his mouth instead of into his windpipe. Treat for shock but do not use the faceup shock position. **AND GET MEDICAL HELP AT ONCE.**

Part of the treatment for jaw wounds is similar to that of neck wounds, because usually there is severe bleeding and consequently danger of choking on blood. Have the patient sit up with his head held forward and down. If his jaw is broken, do not bandage his mouth tightly shut. Place the absorbent part of the dressing over the wound and tie the tails over the top of the head to lend support to the jaw. When treating a jaw wound as in the case of a neck wound, do not use a faceup, head low shock position.

Fractures. When treating patients with fractures, remember two important points: prevent shock, and prevent further injury. Careless handling of patients with fractures can result in further injury.

A fracture should be suspected if there is:

- Tenderness over the injury with pain on movement.
- Inability of the victim to move the injured part.
- Unnatural shape.
- Swelling and a change in color of the skin.

A fracture may or may not have all these signs. If you are not certain whether a fracture is present or not, give the patient the benefit of the doubt, treat the injury as a fracture.

There are two types of fractures. A *closed fracture* (simple fracture) is a break in the bone without a break in the overlying skin. An *open fracture* (compound fracture) is a broken bone with a break in the overlying skin, with the broken bone protruding.

Most fractures require splinting. Proper splinting relieves pain and helps prevent

further injury. The reduction of pain cannot be overemphasized, because excessive pain increases the danger of shock.

Burns. Severe burns are more likely to cause shock than any other types of wounds so be sure to treat for shock whenever a person has been severely burned.

Infection is another great danger in cases of severe burns. To get clothing away from the burn, cut or tear the clothes, then gently lift them off. Do not pull the clothing over the burn and do not try to remove pieces of cloth that stick to the burned area.

If large sterile dressings are available, burned surfaces may be covered, but in the case of severe burns it is best to leave the burn exposed. Never break the blisters or touch the burn.

The victim of burns should drink a lot of water because of the loss of body fluids. If possible, add salt tablets or loose salt to the water. Three or more quarts of water should be consumed by the burned victim every 24 hours. Again medical personnel must be summoned at the earliest possible moment.

Shock. Immediate action must be taken in cases of electric shock. Seconds count as they can mean the difference between death and recovery. Artificial respiration is the fundamental first aid measure for this emergency. A person coming in contact with a "live wire" is the usual cause of electrical shock. If the switch is nearby, turn it off, but do not spend time hunting for the switch. Remove the victim from the wire by using a dry wooden pole, dry clothing, rope, or any nonconductor. Be sure not to touch the wire or victim with your bare hands or you will end up in the same condition as the victim. Artificial respiration should be started immediately after freeing the victim from the wire.

Emergencies from Toxic Substances. AFM 127-101 should always be consulted from current information relative to chemical hazards. As an airman, you can expect to come in frequent contact with potentially dangerous substances. Fuels, solvents, and fire extinguishing agents are examples of such materials. Overexposure to these, and many other substances, can result in severe illness or death. Remember, the early effects of toxic substances are often difficult to detect; so **BE ALERT!**

Fuels. Some fuels may present a potential hazard. Look for these symptoms in your self and others: drowsiness, headache, lassitude, a sense of well-being and buoyancy, excitement and disorientation; and then, in a later stage a

reduced level of consciousness, convulsions, and finally coma. Immediately remove a person to fresh air if he develops any of these symptoms. Normally, fresh air is all that is needed for mild contamination. If clothing has been saturated with fuel, remove the affected clothing. Cleanse the skin immediately with large amounts of water.

If the victim is found unconscious, remove him to fresh air and give him oxygen if available. Keep him warm. Give artificial respiration if he is not breathing and get medical help as soon as possible. The best first aid for toxic fuel, as for all toxic substances, is to practice correct preventive measures.

Solvents. Solvents compose another group of chemicals that often prove toxic. As is true in any case of toxic poisoning, immediately remove the victim from the contaminated area, remove any clothing that is saturated, and thoroughly wash the contaminated skin.

Fire-extinguishing agents. The chemicals commonly involved are methyl bromide, carbon tetrachloride, and chlorobromomethane. Victims of these materials may first notice headache and dizziness, followed by nausea and vomiting. Because of the extreme toxicity of methyl bromide, exposure to it in small, but nevertheless harmful, amounts over a period of time can result in death.

Remove a person exposed to extinguishing agents to fresh air. In the event of spillage on the skin, wash with soap and water. Thoroughly irrigate the eyes with water if they are affected. Administer oxygen in a case of methyl bromide poisoning.

Exercises (027):

1. List the most common types of injuries.
2. Name emergencies resulting from toxic substances.
3. Explain the symptoms of shock.
4. What are considered the three lifesaving steps?

5. A victim's leg *will not* stop the gushing of blood. Name a lifesaving step that you would perform.

6. What is the fundamental first aid procedure for electric shock?

7. A victim of electric shock has no pulse sensation from the wrist. To which area would you go to try and locate a pulse beat?

028. List the common methods of artificial respiration, and cite the requirements for proper heart-lung resuscitation.

Heart-Lung Resuscitation. Resuscitation procedures described herein are in two parts; which, when combined, constitute heart-lung resuscitation. These procedures are applicable to victims of electrical shock, heart failure, drowning, suffocation, and certain other causes; however, the original consideration here is electrical shock.

Artificial respiration is applicable where respiration has stopped, but there is a pulse however slight. The easiest place to detect the pulse is not in the wrist, but in the throat on either side of the windpipe near the collarbone. In cases where no pulse is apparent, use closed chest cardiac massage along with artificial respiration.

Closed chest cardiac (heart) massage is the rhythmical compression of the heart without opening the chest by surgery. It is designed to provide an artificial circulation in order to keep blood flowing to the brain and other organs until the heart's beat has been reestablished. Closed chest cardiac massage is used in cases where the heart has stopped beating (cannot detect a pulse).

The primary reason for the heart's ceasing to beat is insufficient oxygen to the vital centers. This could result from smothering. Other reasons include electrical shock, excessive bleeding, shock, heart disease, effects of certain drugs, and even anxiety.

When the heart stops beating or breathing stops, it is always an emergency. Be calm; think; act! Time is of the utmost importance—SECONDS COUNT! If you are alone, or there are only two of you to conduct emergency aid, DO NOT TAKE THE



Figure 2-2. Clean victim's mouth.

TIME TO SEND FOR HELP. If additional personnel arrive, then send for medical personnel. The great danger when the heart or breathing stops is the lack of sufficient oxygen carried in the blood to feed the brain. The brain is the most sensitive tissue of the body and the results of a shortage of oxygen becomes severe within a few minutes (usually about three) after breathing and circulation are cut off. Thus, while a victim who has had delayed resuscitation may live, he faces the possibility of extensive brain damage—a human vegetable.

Mouth-to-Mouth Method. This method of artificial respiration is accomplished by executing the procedure listed below.

1. Place the casualty on his back (faceup). Do not put anything under his head as it may flex the neck, causing the air passages to be blocked.

2. Quickly clear his mouth of any foreign matter by running your fingers behind his lower teeth and over the back of his tongue. Wipe out any fluid, vomitus, or mucus (see figure 2-2). This cleaning should not take more than a second or two since little time should be lost in getting air into the casualty's lungs.

3. If available (do not waste time looking for these materials), place a rolled blanket or some other similar material under the shoulders so that the head will drop backward. Tilt his head back so that the neck is stretched and the head is in the "chin-up" position (see figure 2-3). This aligns the air passages so that they do not become blocked by kinking or pressure.

4. Place your thumb into the corner of his mouth and grasp the lower jaw firmly. Lift the lower jaw forward to pull the tongue forward out of the air passage. Do not attempt to hold or depress the tongue.

5. With other hand, pinch the nose shut in order to prevent air leakage:

6. Take a deep breath and open your mouth wide. Seal your mouth around the casualty's mouth and your thumb, and blow forcefully (except for infants and small children) into his mouth until you see his chest rise (see figure 2-4). If the chest does not rise, hold the jaw up more forcefully and blow harder while making sure there is no blockage of the air passage and no air leakage around the mouth or nose.

7. When his chest rises, stop blowing and quickly remove your mouth from his. Take another deep breath while listening for his exhalation. If his exhalation is noisy, elevate the jaw further.

8. When exhalation is finished, blow in the next deep breath. The first five to ten breaths must be deep (except for infants and small children) and given at a rapid rate in order to provide rapid reoxygenation. Thereafter, continue breathing at a rate of 12 to 20 times a minute.

CAUTION: Excessively deep and rapid breathing may cause you to become faint, to tingle, and even to lose consciousness. Therefore, after the first five to ten breaths, adjust your breathing to a rate of 12 to 20 times a minute with only moderate increase in normal volume. In this way rescue breathing can be continued for long periods without fatigue.

9. After performing rescue breathing for a period of time, you may notice that the casualty's stomach is bulging. This is due to air being blown into the stomach instead of the lungs. Although an inflation of the stomach is not dangerous, it makes inflation of the lungs more difficult. Therefore, when you see the stomach bulging to a marked degree, gently apply pressure to the stomach with your hand between inflations.



Figure 2-3. Position head and lower jaw.

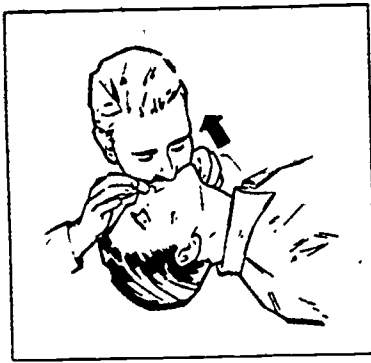


Figure 2-4. Apply mouth-to-mouth respiration.

10. As soon as artificial respiration has been started and while it is being continued, an assistant should loosen any tight clothing about the casualty's neck, chest, or waist. **KEEP THE PATIENT WARM.**

11. Continue artificial respiration without interruption, until natural breathing is restored or until a physician declares the patient is dead.

12. To avoid strain on the heart when the patient revives, he should be kept lying down and not allowed to stand or sit up. He should be kept warm. Give him a warm drink, such as coffee or tea.

13. A brief return of natural respiration is not a certain indication for stopping the resuscitation. Frequently the patient, after a temporary recovery of respiration, stops breathing again. The patient must be watched, if natural breathing stops, artificial respiration should be resumed at once.

Closed Chest Cardiac Massage. It is imperative that blood circulation be maintained while the mouth-to-mouth respiration is being performed. A quick method of determining if the heart has

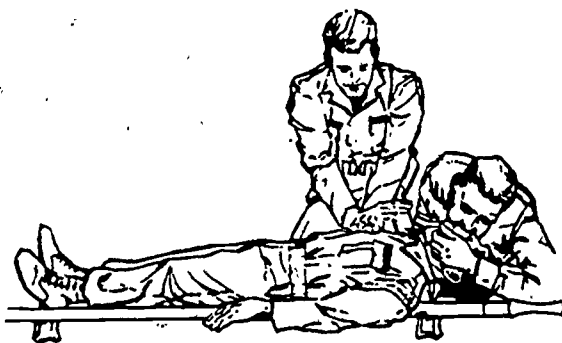


Figure 2-5. Two-person heart/lung resuscitation method.

stopped beating is to lift the victim's eyelid and observe the pupil. If the pupil is dilated (enlarged), the heart has stopped beating and artificial blood circulation must be maintained throughout the revival procedure, or until natural heartbeat is reestablished.

Follow the procedure listed below to establish and maintain circulation.

1. Lay the patient faceup on a solid support, such as the floor, ground or pavement. A bed or couch is too soft.

2. Clear the patient's throat and mouth of any foreign matter.

3. Begin mouth-to-mouth resuscitation simultaneously with heart massage. If two people are available, one gives mouth-to-mouth resuscitation while the other gives closed chest cardiac massage (see figure 2-5). If only one person is available, alternate eight counts of cardiac massage with two counts of mouth-to-mouth breathing.

4. Kneel at right angles to the patient's trunk so you can use your weight in applying pressure.

5. Place the heel of your right hand on the breastbone of the patient, with fingers spread and raised so that pressure is only on the breastbone, but not on the ribs (see figure 2-6). Place your left hand on top of the right, and press vertically downward—apply enough

HEART AND THORACIC CAGE

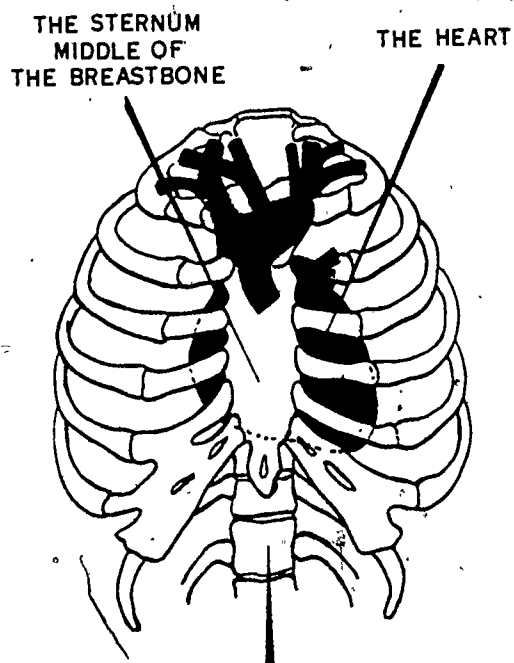


Figure 2-6. Heart and thoracic cage.

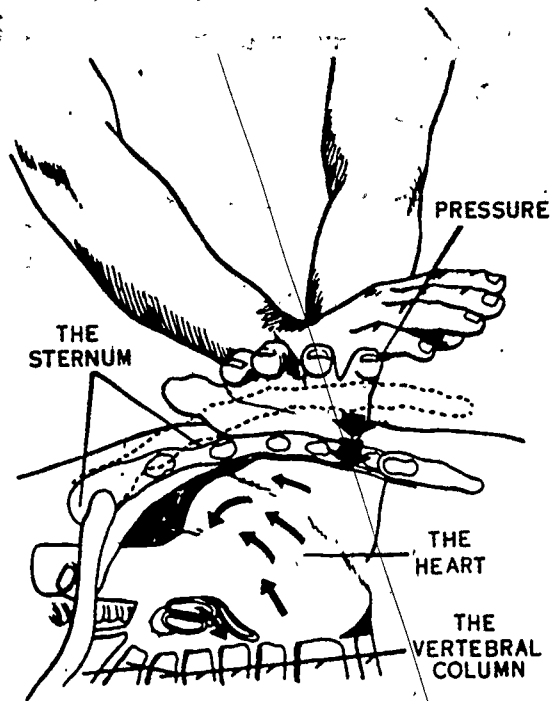


Figure 2-7. Pressure forces blood out of heart.

pressure to depress the breastbone from one and one-half to two inches (see figure 2-7). The chest of an adult, although resistant when he is conscious, becomes surprisingly flexible when he is unconscious.

NOTE: With a child, use only one hand and relatively light pressure. In newborn infants, use of fingers only may be sufficient.

NOTE: The heart is located between the sternum (breastbone) and the vertebral column. Pressure on the breastbone forces the heart against the spine, thus forcing blood into the arteries. Release of pressure allows the heart to refill with venous blood.

6. Release the pressure immediately, lifting the hands slightly (see figure 2-8), then repeat in a cadence OF APPROXIMATELY 60 THRUSTS PER MINUTE.

7. Continue closed chest cardiac massage until you get professional medical aid. Also, if possible, continue to give mouth-to-mouth resuscitation until someone arrives with a tank of oxygen to take over. If you are on your own and the victim shows no response, continue both measures until the victim becomes stiff (rigor mortis sets in). Even trained and experienced medical personnel find it increasingly difficult to say when a person is really dead beyond recall. Again, the most important point is to immediately begin and continue resuscitation efforts.

Back-Pressure Arm-Lift Method. The back-pressure arm-lift method of artificial respiration is shown in figure 2-9. This method may be used when the victim has suffered mouth injuries, or when vomiting is occurring.

Back-Pressure Hip-Lift Method. This is another method of artificial respiration which may be used when the exhaled air method is not desirable, and when arm injuries prevent the use of the arm-lift method. (See figure 2-10.)

Exercises (028):

1. What are the common methods of artificial respiration? When may these methods be used?
2. What is heart-lung resuscitation?
3. List the requirements to accomplish heart-lung resuscitation by (1) artificial respiration (mouth-to-mouth) and (2) closed chest cardiac massage.

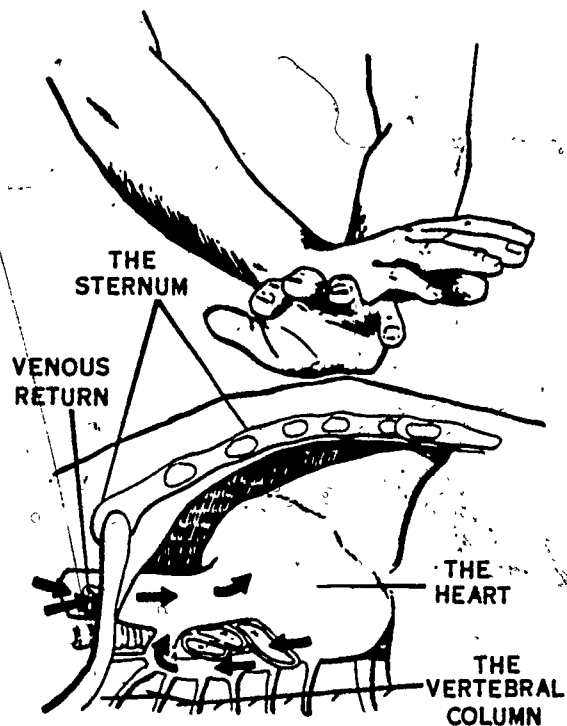


Figure 2-8. Release pressure, heart refills.

029. Identify the different categories of accidents which must be reported.

Investigating and reporting accidents serve a vital function in the overall USAF accident prevention program. All major commands are responsible for investigating and reporting each accident, and for maintaining a followup system to make sure that corrective action is taken. A personal report must be submitted by the commander of any subordinate unit that has an accident that causes death or serious casualties, or extensive property

damage. The severity of an accident is determined by the resulting disability classification. The disability classifications used are fatal injury, permanent total disability, and permanent partial nondisabling injury. Actually, the severity of the accident greatly determines the reporting procedures, but all accidents, no matter how big or small, must be reported.

Exercise (029):

1. How is the severity of an accident determined?

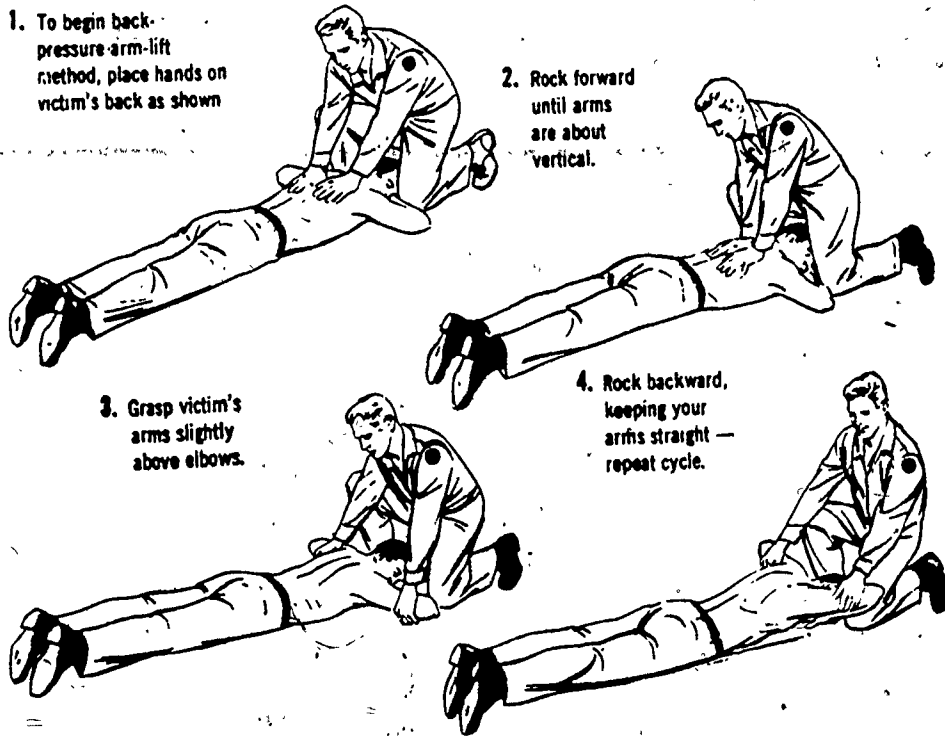
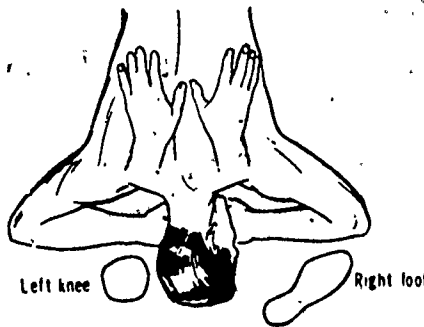
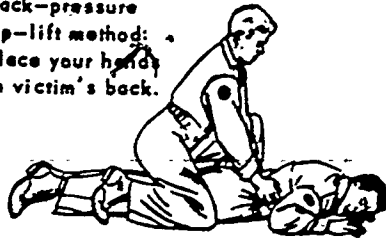


Figure 2-9. Back-pressure arm-lift method.

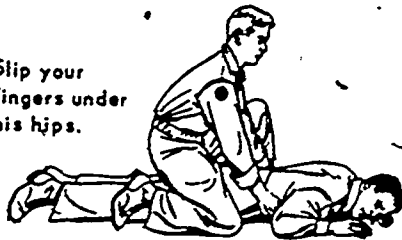
1. Back-pressure hip-lift method: Place your hands on victim's back.



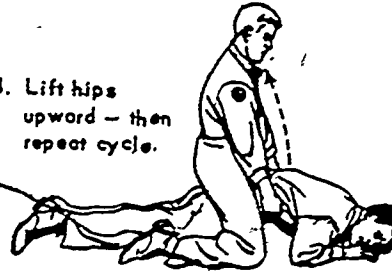
2. Lean forward slowly pressing downward.



3. Slip your fingers under his hips.



4. Lift hips upward - then repeat cycle.



1A-022

Figure 2-10. Back-pressure hip-lift method.

2. What are the disability classifications or categories?

3. What accidents must be reported?

030. List the regulations and forms used in accident reporting.

Before an accident occurs which would require you to report, make sure you have done your best to find and report any and all unsafe acts or habits. Reporting these conditions will result in a decrease of accidents. Remember every member of the Air Force has the responsibility of reporting all unsafe acts or conditions that are found.

At base level, we are primarily concerned with the accident reporting procedures set forth by the base director of safety. He, in turn, must abide by AFR 127-4, *Investigation and Reporting US Air Force Accidents and Incidents*, and the major command's supplement thereto. If any of the personnel in

your section are involved in an accident, the ground safety office, with your supervisor's assistance, is required to fill out forms reporting the circumstances and the extent of damage and injuries sustained. Although there are several forms, the ones most important are AF Form 711, USAF Accident/Incident Report, and AF Form 711a, Ground Accident Report. Also, most bases or centers have developed local forms, which must be processed by the organization directly concerned with the accident.

In conclusion, it should be noted that much time and expense is involved in investigating and reporting accidents. Although the majority of accidents are of a minor nature, they involve research of various publications, paperwork, and followup action. You should be instilled with the desire to think before you make a move.

Exercises (030):

1. Which AF regulation should be consulted before completing an accident report?

2. Which two forms would you be concerned with, concerning accident reporting?

MODIFICATIONS

Chapter 3 of this publication has (have) been deleted in adapting this material for inclusion in the "Trial Implementation of a Model System to Provide Military Curriculum Materials for Use in Vocational and Technical Education." Deleted material involves extensive use of military forms, procedures, systems, etc. and was not considered appropriate for use in vocational and technical education.

Prints and Tools

ONE OF THE tasks of a heating specialist is to repair broken lines, whether they are steam, water, or fuel. To repair a broken line, you must first locate it, and in many instances you will have to use a blueprint to do this. This poses two problems for you. How will a blueprint help you in locating broken lines if you don't know how to interpret them? And, once you do find the broken line, do you know the proper use of the correct tool necessary for the repair?

This chapter deals with the theory, types, and care of blueprints, also the symbols, scales, and details used in blueprints. It also will provide information necessary for you to select, care, and use the proper tool for any given task.

4-1. Theory of Prints

A diagram which will serve as a chart to show the heating specialist how to do the best possible job is called a blueprint. If he does not already have the skill to interpret the information such a chart presents, the apprentice heating specialist must immediately acquire it. The purpose of the following learning objectives is to help you learn and perfect the skill of blueprint reading.

044. Identify the two drawings needed in the process of making blueprints, and list in sequence the steps of the process.

Blueprints are exact copies of mechanical drawings, which are generally drawn accurately to scale. Blueprints, or just *prints* as they are often called, are made from drawings in much the same way that photographs are made from negatives.

The negative for the blueprint is known as a tracing. It is made by placing a sheet of special translucent tracing paper or cloth over the drawing. Every line, symbol, and item of

information on the drawing is then traced on the tracing paper or cloth with black waterproof ink or a special black pencil. After the tracing is completed, it is checked and the original drawing is filed for future use. Some drawings are made directly on the tracing material in pencil; then they are traced with the ink or with a special black pencil. This shortcut saves time and material, and the product is satisfactory for most jobs.

Now, the tracing is placed on the sheet of clear glass, mounted in a special frame, and covered with a sheet of sensitized light-green blueprint paper. The padded back of the frame is secured behind the blueprint paper to keep the two sheets together. The front of the frame is then exposed to a strong light, which penetrates the tracing except where the lines are drawn and causes chemical action to take place in the coating on the print paper. There is no chemical action under the lines of the tracing because the black lines block off the light.

After the proper exposure, the print is removed and washed in clear water to remove the unexposed chemical. The exposed portions of the print paper turn a deep blue during the washing; of course, the lines are white. Sometimes the print is first washed in a weak solution of bichromate of potash to intensify the blue color. If this solution is used, the print must again be washed in clear water.

Any number of prints can be made from one tracing, if it is handled carefully. When large numbers of prints are required, they are made in a special blueprint machine, but the same principle is involved.

After the prints are made, there are a few precautions that should be observed in order to keep them in a higher degree of usability. Blueprints are not just scraps of paper. They are valuable permanent documents that can

be used again and again. Prints must be kept out of strong sunlight; otherwise they will fade. They must not be allowed to get wet or smudged in any way, such as with grease, crayon, pencil, etc. No sort of notations should be made on a print without the proper authority.

When instructions to mark a blueprint are given, a yellow pencil is used. Ordinary (black lead) pencil marks are hard to see on a colored background. Distances should not be measured on a blueprint! If you cannot find a dimension on one view, look at another view. If you still cannot find it, ask someone who knows. Why not measure? The original mechanical drawings might not have been drawn absolutely to scale. Perhaps the print paper has shrunk or stretched. You cannot take chances! You should take care of a blueprint just as you would the picture of your wife or girl friend so that the prints will be in good condition and ready to look at the next time.

Exercises (044):

1. From what does a blueprint originate?
2. What is the negative for a blueprint called?
3. How many procedures are involved in making a normal blueprint? What are they?

045. List the types of prints, and identify those that are processed differently from blueprints.

Blueprints are not always blue. All kinds of reproduced drawings are commonly referred to as blueprints or just prints. They can be white, brown, black, gray, or other colors.

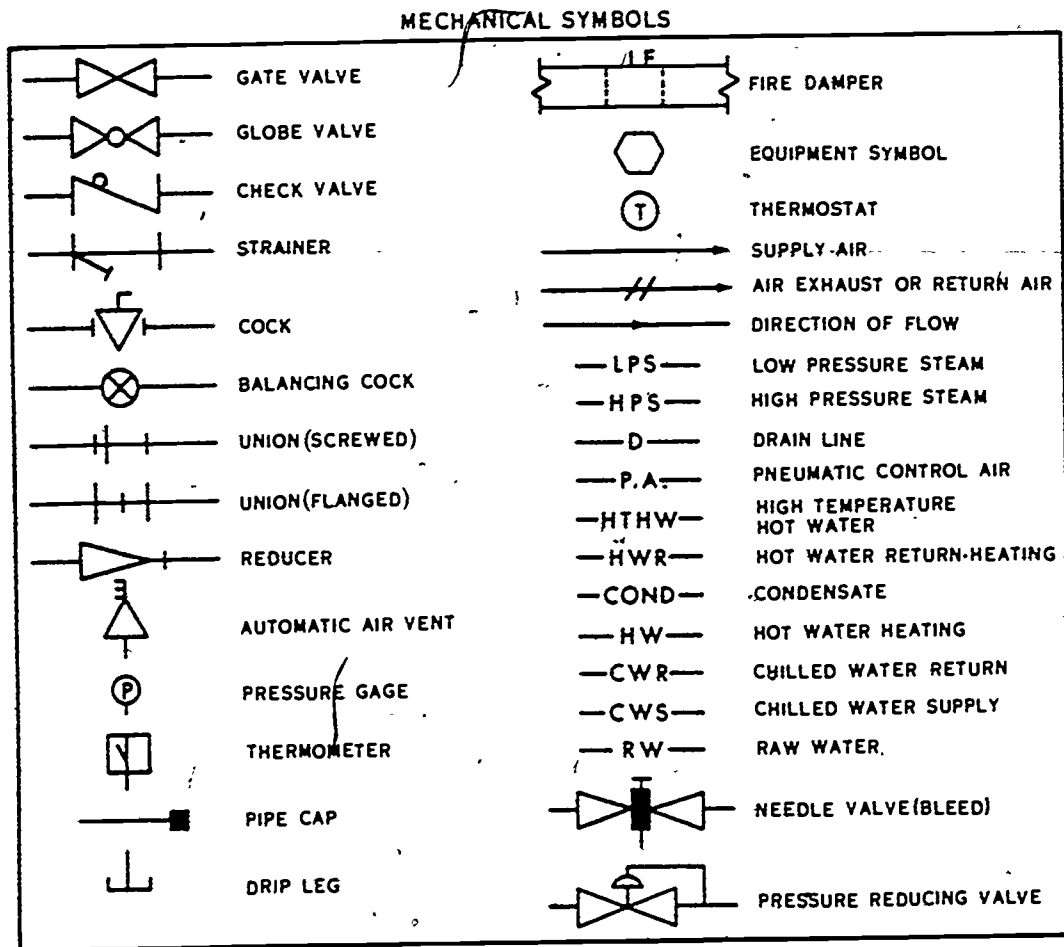


Figure 4-1. Mechanical symbols.

ELECTRICAL SYMBOLS







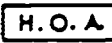











	INCANDESCENT FIXTURE OUTLET		BRANCH CIRCUIT CONCEALED IN CEILING OR WALLS
	JUNCTION BOX		BRANCH CIRCUIT CONCEALED IN FLOOR
	THERMOSTAT		BRANCH CIRCUIT EXPOSED
	FLUORESCENT FIXTURE OUTLET		GROUND CABLE NR 2
	CLOCK OUTLET		MOTOR (NUMBER INDICATES HP)
	HAND-OFF AUTOMATIC SWITCH		DISCONNECT SWITCH
	SWITCH		PHONE OUTLET
	DUPLEX CONVENIENCE OUTLET		GROUND ROD
	SPECIAL PURPOSE		GROUND
	120V-1Ø EXPLOSION PROOF OUTLET		MAGNETIC MOTOR STARTER
	LIGHTING PANEL	E.P.	EXPLOSION PROOF
	POWER PANEL	W.P.	WEATHER PROOF

Figure 4-2. Electrical symbols.

The color differences result from the different kinds of sensitive papers used in the development processes. You should be able to recognize other prints because you may be working with them. Below are various types of prints.

Blueprints. The blueprint process is the simplest and most generally used copying process for making prints that you will use. The process was discussed in Behavioral Objective 044. As you know, this process

produces a print with a blue background and white lines.

Vandykes. Vandyke paper is a thin sensitized paper which turns dark brown when exposed to light and properly finished. A reversed negative of a tracing may be made on it by exposing it to light with the inked side of the drawing next to the sensitized side of the paper; then this negative can be printed on blueprint paper, giving a positive print with blue lines on white background.

PLUMBING SYMBOLS










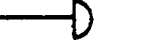

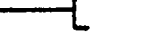


	DOMESTIC WATER (COLD)		CHECK VALVE
	HOT WATER		PLUG VALVE
	HOT WATER RETURN		PRESSURE REDUCING VALVE
	PLANT AIR		PRESSURE OR TEMP RELIEF VALVE
	UTILITY AIR		WELDED CAP
	FILTERED AIR SUPPLY		QUICK DISCONNECT
	FLOOR CLEAN OUT		
	SIGHT GLASS		

Figure 4-3. Plumbing symbols.

PIPING SYMBOLS

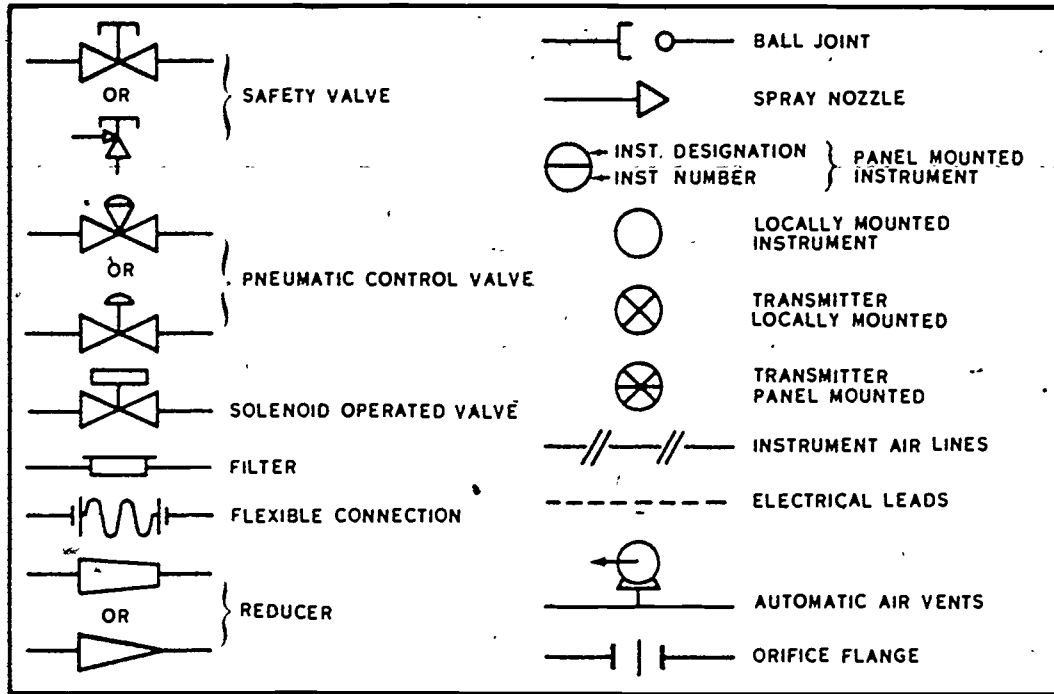


Figure 4-4. Piping symbols.

BW Prints and Director Prints. These prints have black lines on a white background and are made directly from the original tracing, either in a blueprinting machine (and developed by hand) or in a special machine made for the purpose. They are used extensively when positive prints are desired.

Ozalid Prints. This process is based on the chemical action of light sensitive diazo compounds. It is a contact method of reproducing in which the exposure is made in either a regular blueprinting machine or an ozalid "whiteprint" machine, and the exposed print developed dry with ammonia vapors in a developing machine. Standard papers giving black, blue, and maroon lines on a white background are available. Since this process can use transparent papers, cloth, and foils for the original drawing, erasures and additions can be made on the original tracing without altering it.

Photostat Prints. These prints are extensively used by large corporations. In this process the drawings are made on dark background with white lines. The drawing can then be photographed and the photographs may be reduced or enlarged to almost any size.

Exercises (045):

1. List the different types of prints.

2. Which type of print is dried with the aid of ammonia vapors?
3. Which type of print eliminates many of the procedures utilized by the normal blueprint processing?

4-2. Use of Symbols and Scales

In many respects, learning to read blueprints is the same as learning to read the English language. The chief difference lies in the fact that it is a much easier task. In reading, we have letters (SYMBOLS) which combine to form words and lead to ideas.

Hence, we are able to tell other people our thoughts or ideas by writing them on paper, or by telling them directly what we want them to know. In blueprint reading we have first a few basic things to learn. First, there are the symbols to be recognized that correspond to the letters of the alphabet. We also have symbols that represent things or ideas. Second, we have abbreviations for words to save space and time. Third, there is an alphabet of lines that helps us distinguish

dimension lines from object lines. Fourth, and most important of all, is multiview projection, which is sometimes called orthographic projection.

046. From given information, identify symbols familiar to the heating career field.

Symbols used in blueprints are arbitrary or conventional signs, such as characters, abbreviations, etc., used in place of pictured details. A few symbols used in blueprints are located in figures 4-1, 4-2, 4-3, 4-4, 4-5, 4-6, and 4-7. They are relevant to the heating career field.

The most basic symbol and the one requiring the greatest understanding is the line. The thickness of the line and the

configuration used, must be understood for you to use a blueprint or drawing properly. (See figure 4-8.)

The American Standard Association (ASA) has established standards for the width of lines used on drawings. The association approved the exclusion of heavy lines on pencil drawings. However, heavy (wide lines) are still used on ink drawings. Of course, the width of line used on the tracing will be the same as appears on the prints made from the tracing. In reference to drawings, the words "weight" and "width" have the same meaning.

On drawings, the heavier lines will be used for the border, the medium lines will be used for the object, and the finer lines will be used

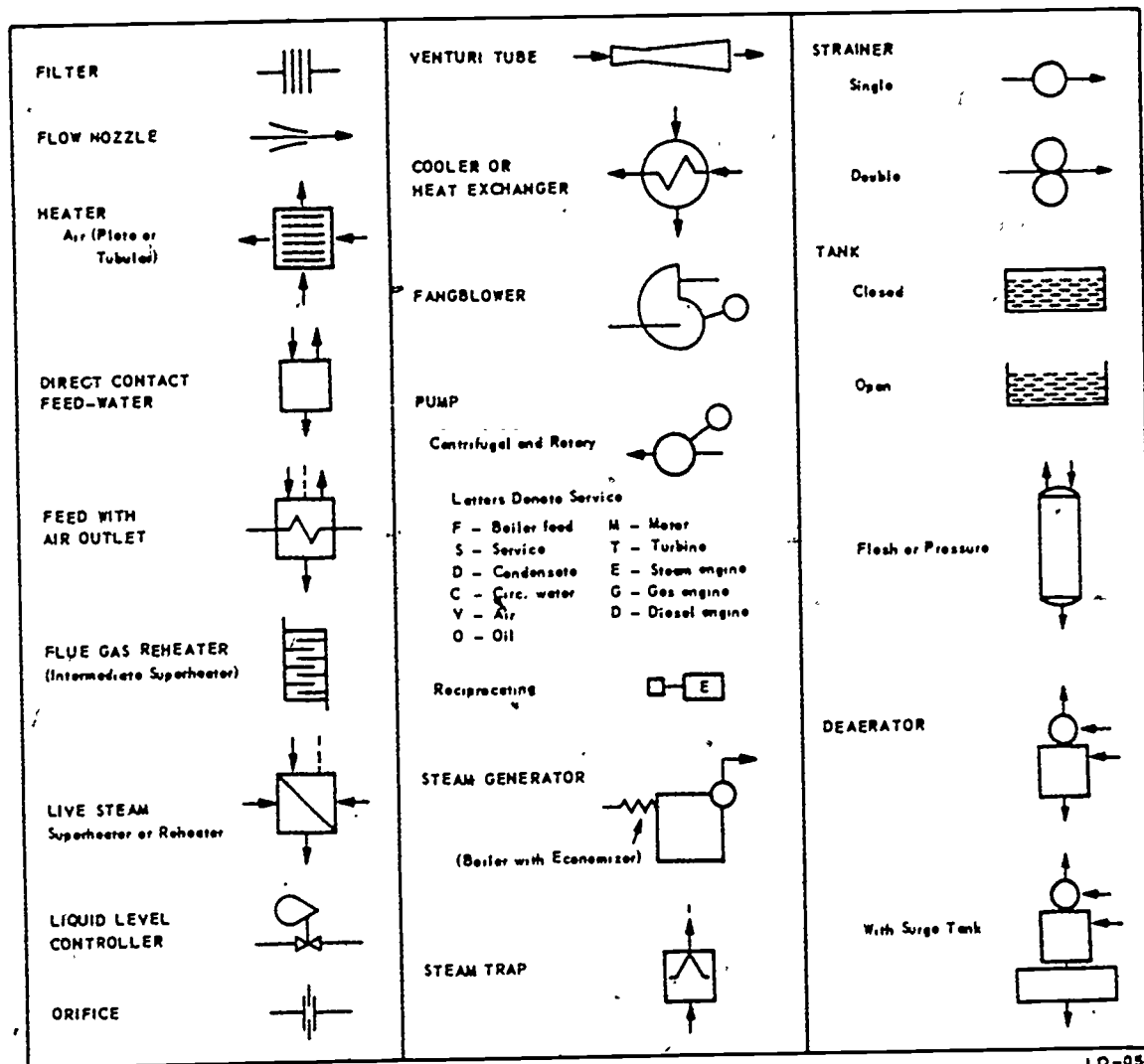
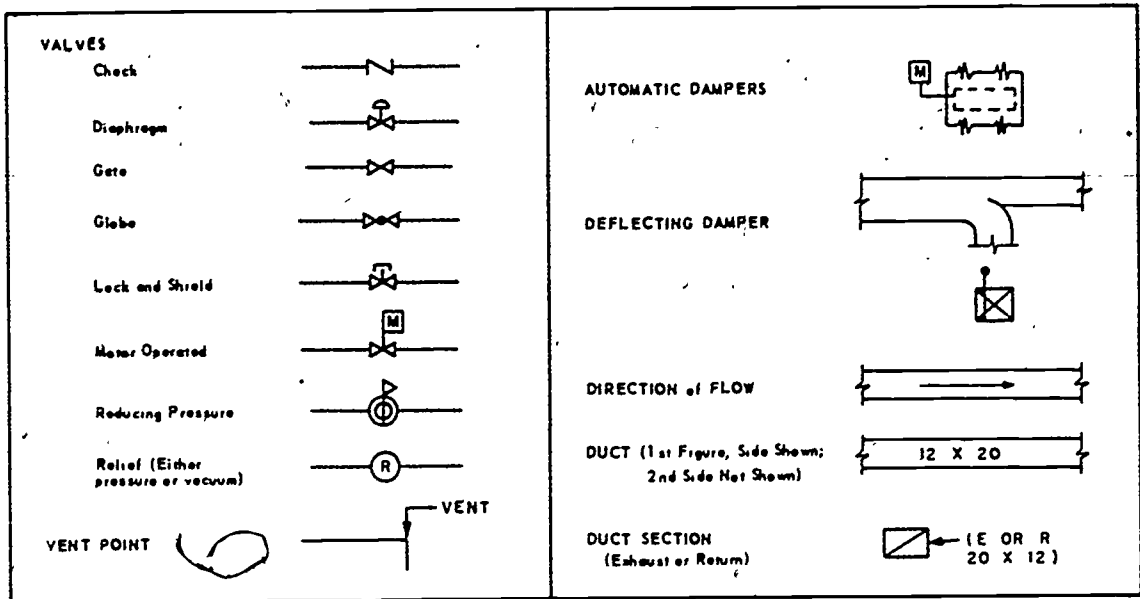


Figure 4-5. Heating power symbols.



LD-055

Figure 4-6. Heating symbols.

for centerlines and dimension lines. The following explanations will aid you in identifying lines used on drawings.

Borderline. (——) The borderline is the heavy line around the outer edge of the print. It informs the reader that the intended illustration is complete within these borders. Exactly what the illustration is supposed to be is noted on the legend in the lower right corner along with other necessary reference information.

Object Line (or Visible Line). (——) The object or visible line outlines the specific item illustrated by the draftsman. It is a medium weight line which shows the shape of the object to the reader. It is used to outline buildings, partitions within the structure, piping, conduit, etc. It is the most important line on the print because it forms the object to which we are referring.

Centerline. (- - -) The centerline is used when it is necessary for the reader to use the center of an object as reference. Consult your symbols and become thoroughly familiar with it; whenever it is used, it usually adds great significance to the drawing.

Extension and Dimension Lines. (——>) Extension lines are used to bring meaning to dimension lines. The centerlines and extension serve as stops for dimension lines. The extension lines do not touch the object, but start about 1/16 of an inch from the

object line and extend about 1/8 of an inch beyond the dimension arrow. In instances where the dimension must be located inside the object, the object lines serve as stops.

Cutting Plane. (——) This is merely a line symbol to give accuracy to the reader as to the view taken by the draftsman (very useful in the machine tool business, but used less in construction drawing).

Section Lining (Shading). Use on detail drawings to indicate material to be used. They also may be used to show a cutaway of an object. (Refer to figure 4-8.)

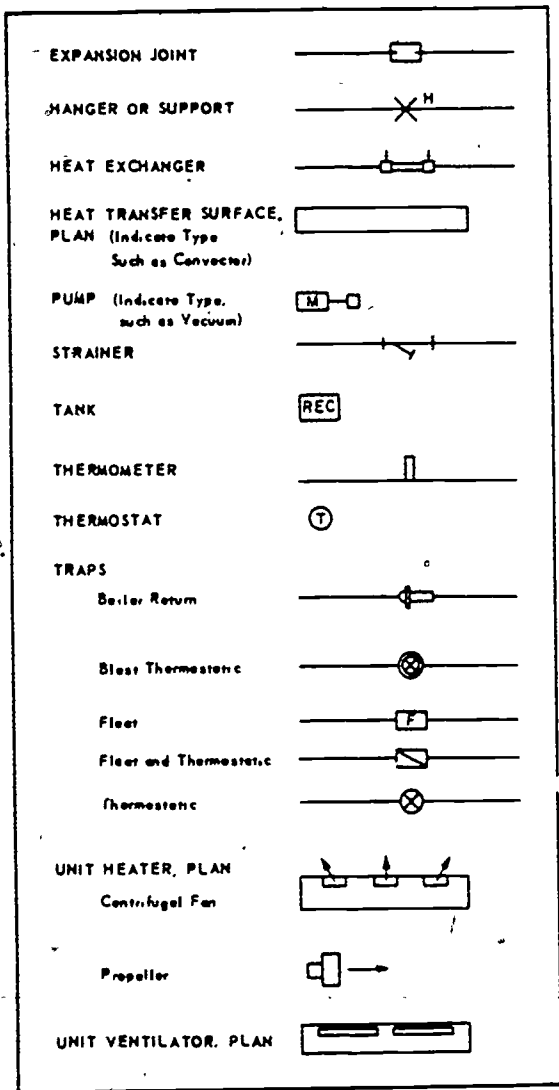
Breaklines. (——) In drawing a detail of piping, shafting, etc., it is usually drawn with breaklines. Uses of conventional breaklines are illustrated in figure 4-9.

Hidden Lines. Hidden lines are medium lines which consist of short dashes evenly spaced (-----) that show hidden features of the object.

Now, go to figure 4-8 and find examples of each line referred to. Study the drawing carefully, leaving no line unexplained.

Exercises (406):

1. If you see a medium weight line on a print going to a water heater you would know that it is a object line or visible line. This would be a symbol for what?



LO-057

Figure 4-7. Heating symbols.

2. Referring to figures 4-2, 4-3, 4-4, 4-5, 4-6, or 4-7, the symbols _____ X _____ and T refer to a _____.

3. How are water lines or steam lines drawn in a detailed print?

047. State the purpose of scaling, and identify different types of scales.

Objects are drawn full size when the details

of the object are clearly shown and the size of the paper will conveniently permit. Enlarged views of sections are made when the actual size of the object is so small that full-sized representations would not clearly present the features of the object. Reduced scale prints are made of large objects that can be shown clearly in a smaller scale. The prime reason for reducing the scale of drawings is to reduce their size so that they can be placed on smaller sheets without crowding the views.

The scale of prints is generally noted in the title block and can be designated as "full size," "enlarged view," or at a reduced scale such as 1" = 10', 1/4" = 1', and others which are similar.

Scaling. The process of measuring dimensions on a blueprint is called scaling. Important dimensions are normally shown on the blueprint and should not be scaled because of the possible distortion of the print on cloth or paper.

Architect's scale. Architect's scales are divided into proportional feet and inches. They are generally used in scaling blueprints for machine and structural work. The triangular architect's scale (see figure 4-10) usually contains 11 scales, each subdivided differently. Six of the scales are read from the right end.

Engineer's scale. Engineer's scales are divided into decimal graduations (10, 20, 30, 40, 50, and 60 divisions to an inch). Figure 4-11 illustrates an engineer's scale. These scales are used for plotting, map drawing, and the graphic solution of problems.

Metric scale. Metric scales, shown in figure 4-12, are used in conjunction with drawings, maps, and the like, which are made in countries using the metric system. The metric system is also being used with increasing frequency in the United States. The scale is divided into millimeters and centimeters.

Graphic scale. Graphic scales, shown in figure 4-13, are lines divided into distances corresponding to convenient units of length of the object represented by the print. They are placed in or near the title block of the print. Since these scales are a part of the print, increasing or decreasing the print will change the scale lengths accordingly.

Methods of Scaling. When you are using the architect's or engineer's scale, the method of scaling is that of determining the scale of the print from the notations given, such as 1" = 10', 1/4" = 1', 1" = 20', and the like. Then,

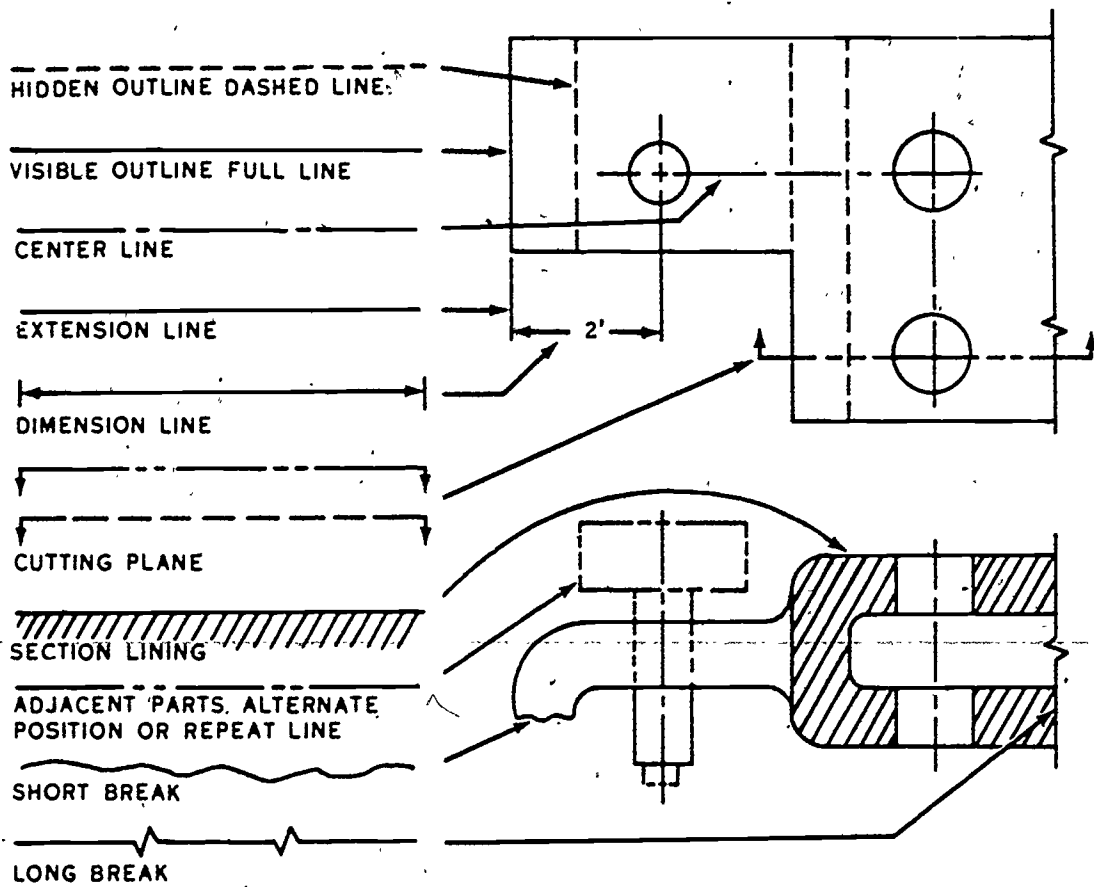


Figure 4-8. Line symbols.

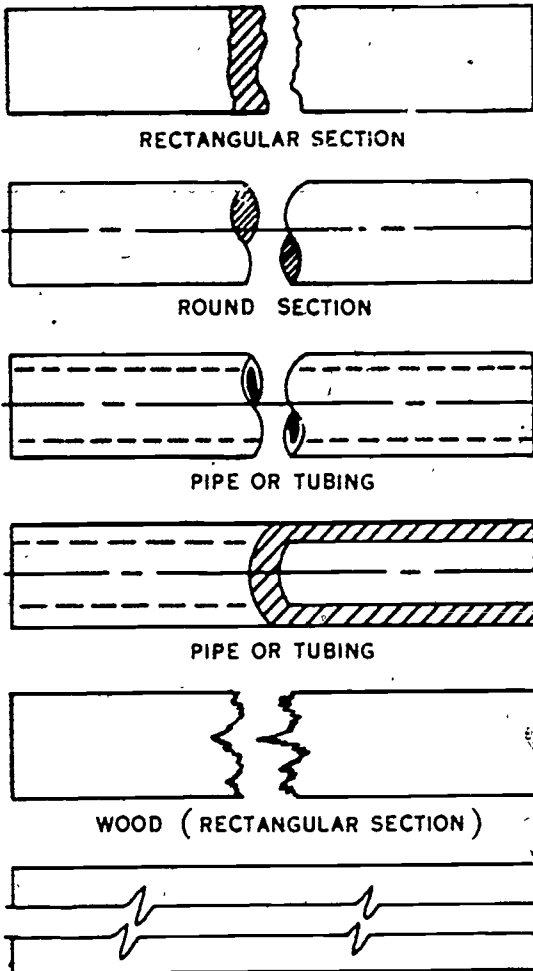


Figure 4-9. Conventional breaks.

you select the corresponding scale on the architect's or engineer's scale. While using the proper scale, measure the desired dimensions on the print. For example, if the scale of the print is 1" = 100', then a dimension that measures 20 divisions on the engineer's scale (10 divisions per inch) represents a distance of 200 feet.

When you are working with graphic scales, the method usually used is that of marking

off the length of the dimensions desired onto a slip of paper, placing the slip of paper on the graphic scale, and reading the distance of the dimension that was marked.

Exercises (047):

1. What is the purpose of scaling?
2. Match the scale in Column A to the proper description in Column B.

- | | |
|---|--|
| <p><i>Column A</i></p> <ol style="list-style-type: none"> 1. Architect's scale 2. Engineer's scale 3. Metric scale 4. Graphic scale | <p><i>Column B</i></p> <ol style="list-style-type: none"> a. A scale divided into millimeters and centimeters used in conjunction with maps, drawings, etc. b. A scale divided into decimal graduations, used for plotting and map drawing. c. A scale divided into feet and inches used for drawing machine and structure work. d. Lines divided into distances corresponding to units of length. |
|---|--|

048. Differentiate between the elevation and plan type views.

A blueprint is usually made up of three different views: the top view, side or end view, and the front view. Figure 4-14 shows how objects appear in each of these views, and figure 4-15 shows how all three views would be laid out on one sheet. The front and side views are called elevations; the top view is the plan view, or architectural drawing.

Elevations. Elevations are merely pictures of an object, as viewed from positions directly in front of each of the four sides. Figure 4-16 shows an elevation plan of the four sides of a cottage. This blueprint gives us a general idea of what the structure looks like. Such elevations are relatively simple and are almost

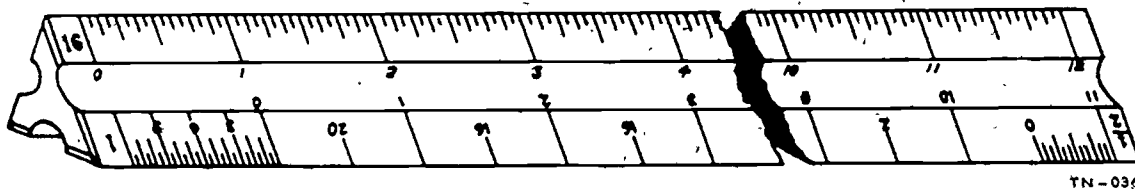
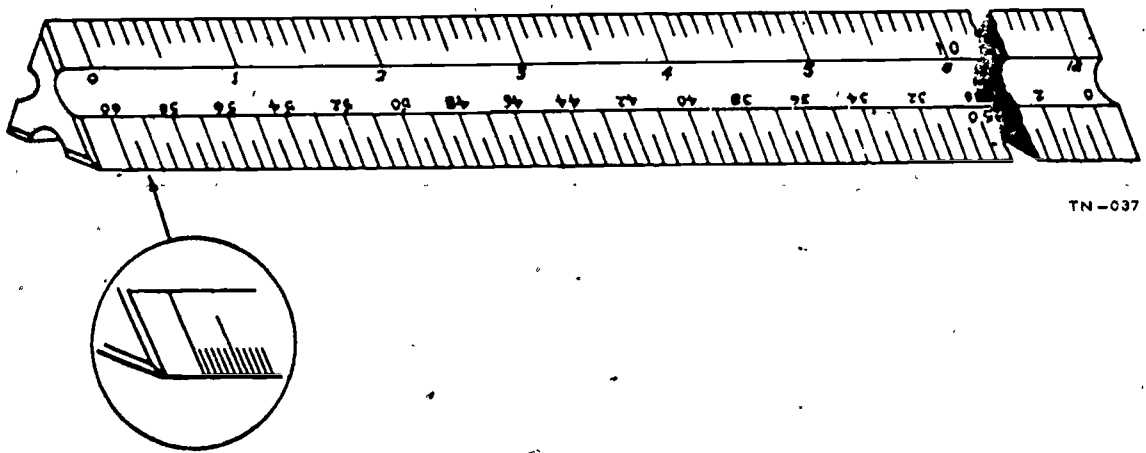


Figure 4-10. Architect's scale.



TN-037

Figure 4-11. Engineer's scale.

self-explanatory even to one who knows very little about blueprints. The heating specialist uses elevations to clarify other views. Each elevation gives additional information, such as the type of roof, kind of siding, and the dimensions. Figure 4-17 is a front elevation plan of a small cottage. Note the information and dimensions on the elevation plan.

Plan View. Plan views, or architectural blueprints, show the interior arrangement of a building. These blueprints are made looking down on the building from a point directly above. Horizontal surfaces, such as floors, appear without distortion. All vertical surfaces, such as walls, appear as lines. A plan view of the same cottage is shown in figure 4-18.

Plan views usually show the outside shape of a building, the arrangements of the rooms, and the sizes and the shapes of rooms. They often give the types of materials to be used; the thicknesses of walls and partitions; and the types, sizes, and locations of doors and windows. They provide details of framework and structure; and they show the type, size, and location of mechanical equipment, such as heating plants, radiators, plumbing, electrical fixtures, and appliances. Also included are the instructions concerning the

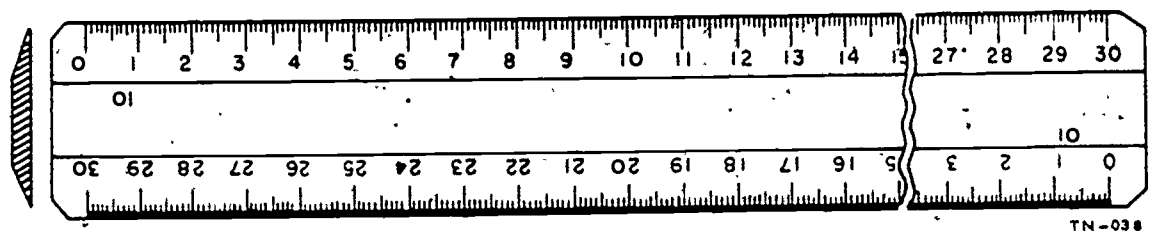
construction and the installation work. The plan view that is illustrated in figure 4-18 is quite easy to read and understand once you know what each line and symbol means.

Exercises (048):

1. Differentiate between the elevation and plan views.
2. Which type view would you normally use when you plumb a housing unit?

4-3. Mechanics' Handtools

Tools are vital to the mechanic's job, and without them he is useless. Today, there are still many jobs being done in the Air Force with handtools. Regardless of the job to be done, the good mechanic must have, choose, and use the correct tools to accomplish a maintenance task properly. Without tools and the knowledge of how to use them, the



TN-038

Figure 4-12. Metric scales.

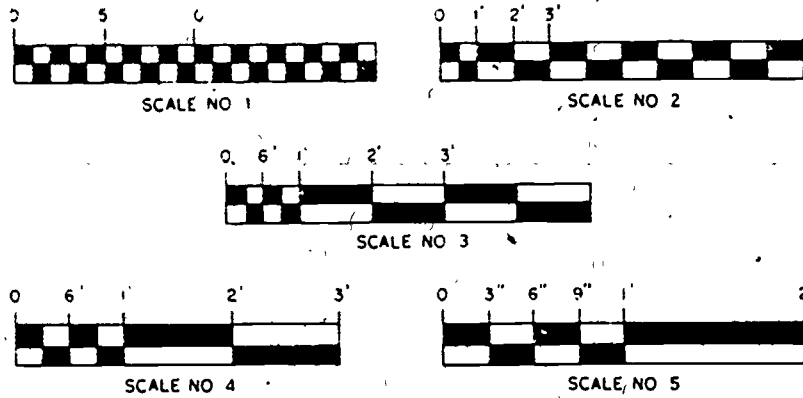


Figure 4-13. Graphic scales.

mechanic wastes time and cuts down his efficiency.

Besides, without proper tools, the mechanic can cause injury to himself or his coworkers. Statistics show that handtools in use are responsible for a large portion of the accidental injuries to mechanics. The knowledge of the proper use of handtools will not eliminate all accidents, but if know-how is used, the accidents and injuries will be greatly reduced.

049. Identify the types and uses of gripping tools.

Wrenches. Wrenches are tools used for tightening and removing nuts, boltheads, and

capscrews. They are also used for gripping round items, such as pipe, studs, and round rods. Wrenches are generally classified as adjustable jaw wrenches, socket wrenches, open end wrenches, box end wrenches, and pipe wrenches, and are shown in figure 4-19.

Pipe wrench. The pipe wrenches range in size from 6 to 60 inches. The offset wrench may be as long as 36 inches. (See fig. 4-20.) Pipe wrenches are used for turning pipe, round rod, and smooth fittings which do not offer a gripping surface for other types of wrenches; however, the bit of the jaws mars the work. Pipe wrenches should not be used on nuts or bolts. The size of these wrenches is designated by their overall length. For example an 18-inch wrench has a handle of 1 1/2 feet long and handles pipe up to 2 inches in diameter.

When using a pipe wrench be sure that the teeth on the jaws are clean and sharp. When

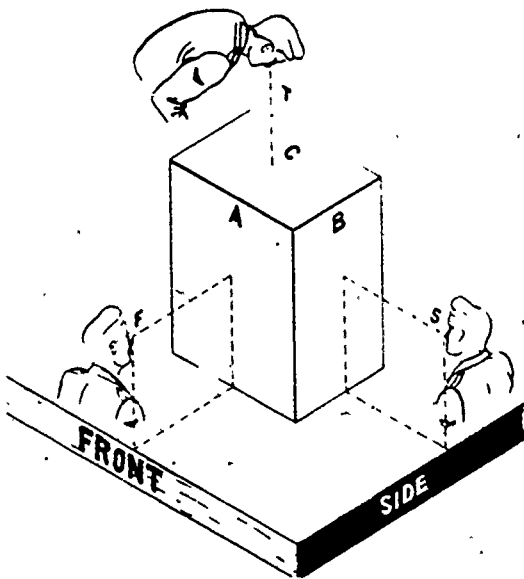


Figure 4-14. Three views of an object.

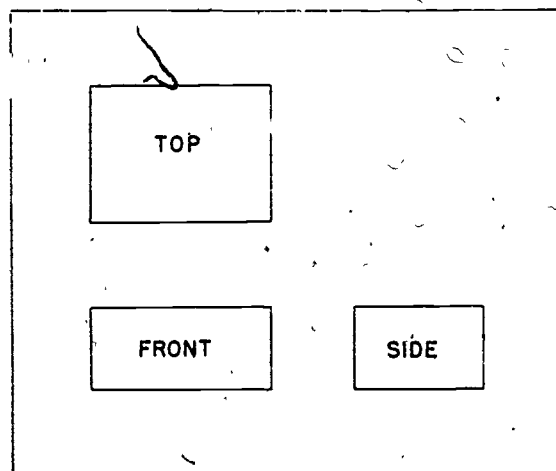


Figure 4-15. Three views of an object placed on one sheet.

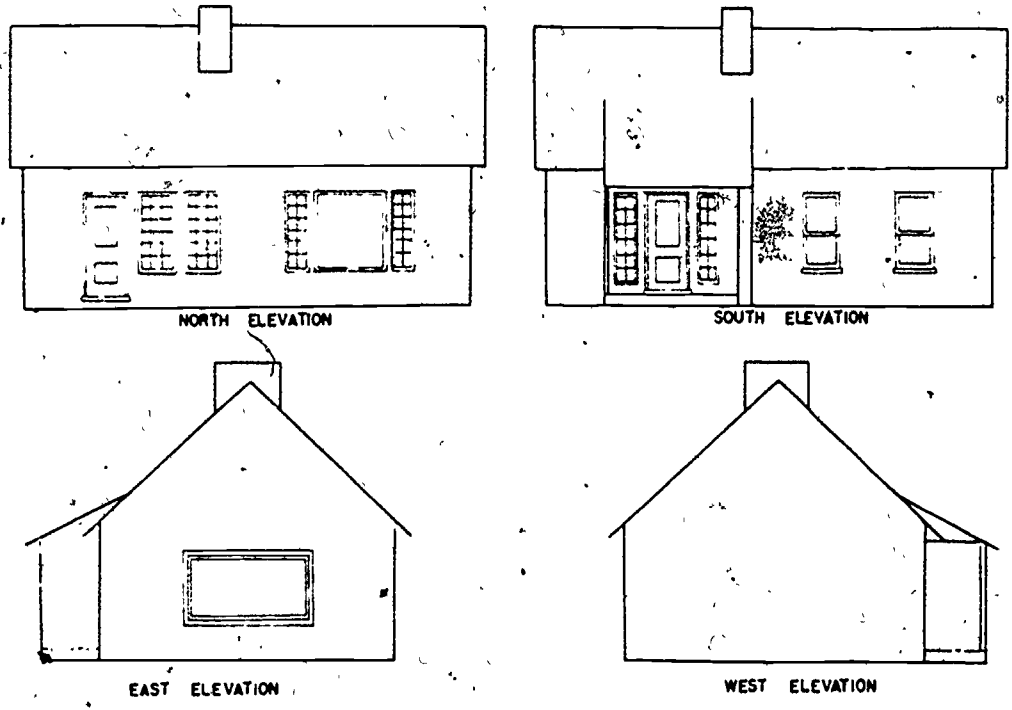


Figure 4-16. Elevation plan of a cottage.

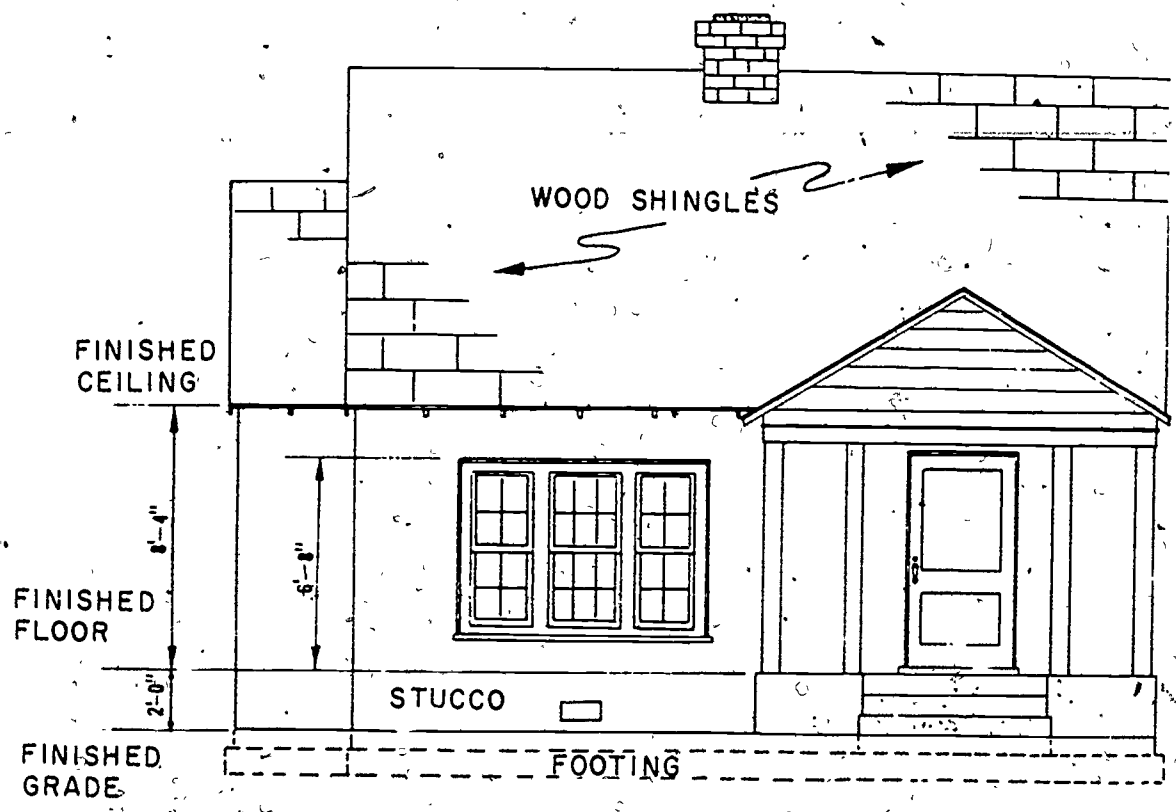


Figure 4-17. Front elevation of a cottage.

the teeth become dull, they can be sharpened with a file. When they become worn out, they can be replaced by inserting a new hook jaw and a heel jaw.

The housing or main body of the wrench is made very strong and will stand tremendous strain, but DO NOT use a pipe extension on the handle; use a larger wrench. Only a pipe wrench that is in good condition should be used. If you cannot get parts, the wrench should be taken out of service immediately. Keep the threads on the hook jaw and nut cleaned and oiled.

NOTE: Never use pipe wrenches on square or hexagon-shaped objects except pipe unions.

Adjustable end wrench. The open end adjustable wrench is a common tool used by most tradesmen. (See figure 4-21.) It is also

the most misused tool of all and is commonly hammered on and even used backwards, as shown in figure 4-21. It is often called a knuckle buster because it generally slips on a nut if improperly used. It is a good wrench when used properly. The main precaution is to adjust the wrench so it will fit the nut or bolthead snugly so it will not slip and cause the edges of the nut to become rounded or burred when pressure is applied. The face of the jaws must be free of burrs and deep nicks.

Adjustable wrenches are made so that their jaws can be opened or closed to fit the flats of a nut or bolthead. The size of the wrench is designated by its overall length.

Open end wrench. Open end wrenches fit standard size nuts. They are lightweight, strong, and convenient for doing work in limited space. Because the jaws are set at an

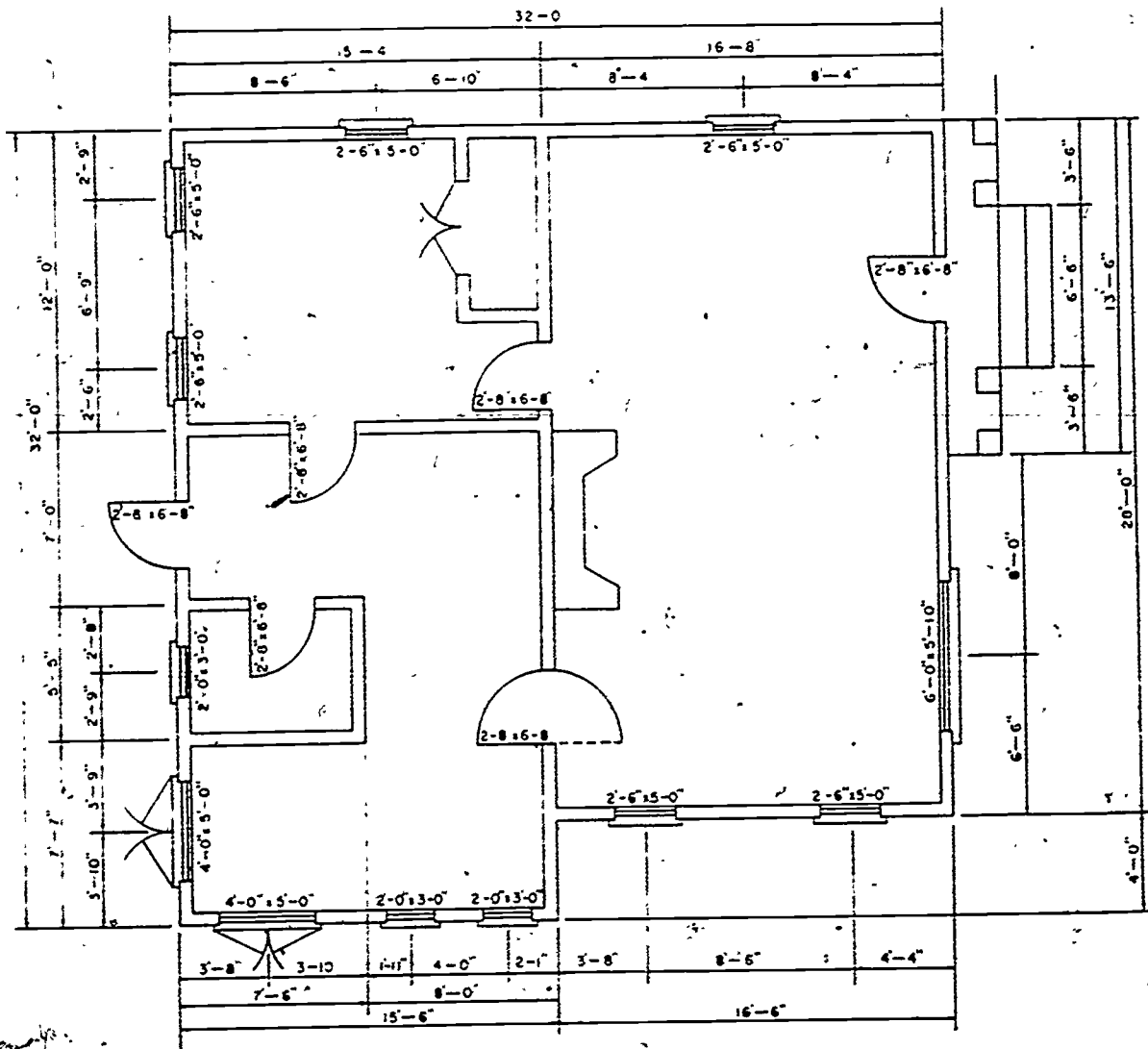


Figure 4-18. Plan views of a cottage.

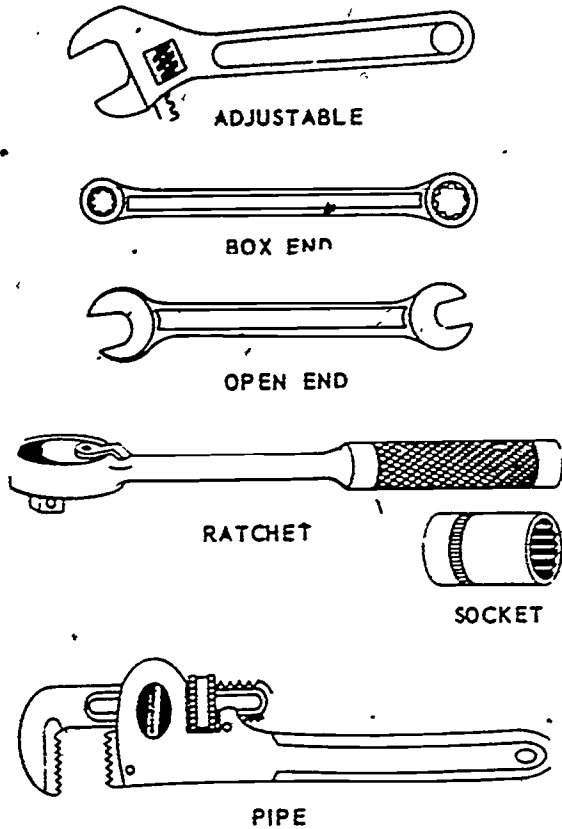


Figure 4-19. Types of wrenches:

angle, usually 15° or 90°, it is easy to work in close places by turning the wrench over after each movement. The length varies according to the size of the opening. Some open end wrenches are angular in construction. These are used in places where straight wrenches cannot be used. (See figure 4-22.)

Box end wrench. Box end wrenches are used for general purpose work. These wrenches are well suited for operation in close

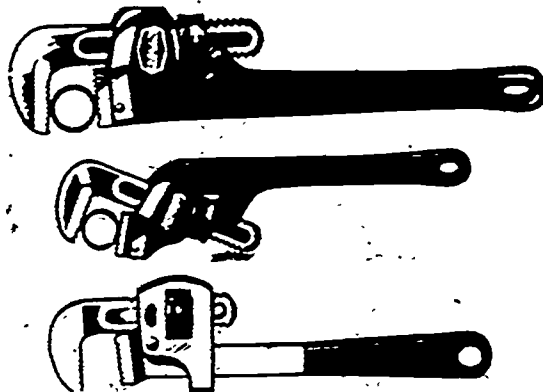


Figure 4-20. Pipe wrenches.

places because their heads are small. They can be used on nuts which cannot be grasped with other types of wrenches. Most box end wrenches have 12 points and most nuts have six sides; therefore, as little as one-twelfth of a turn can be taken each time the wrench is shifted. The length of the wrench varies according to the size of the opening. (See figure 4-23.)

All wrenches used by the heating mechanic should be kept in good condition. The ones showing any defects such as spread or distorted jaws, bent handles, or cracks, will be taken out of service if you cannot replace the parts. As mentioned previously, the tools must be kept clean and all moving parts oiled with light oil.

Socket wrenches. Socket wrenches are frequently used where it is necessary to operate in close or hard-to-reach places. The sockets are supplied in sets to fit standard size nuts and are readily fitted onto or removed from the handle. A ratchet handle is usually included in the set so that the nut can be completely tightened without removing the socket from the work. Another accessory for the socket wrench is the torque wrench. On some makes of torque wrenches a pointer indicates on a scale the amount of force being applied. On others you set a dial for the amount of torque desired.

Pliers. Each pair of pliers is designed for a specific job. There are cutting, gripping, or holding types, consisting mainly of a pair of jaws, a pivot point, and a pair of handles. The sidecutting (lineman's) pliers and diagonals are of the cutting types. The diagonals are for close cutting, while the sidecutters are used

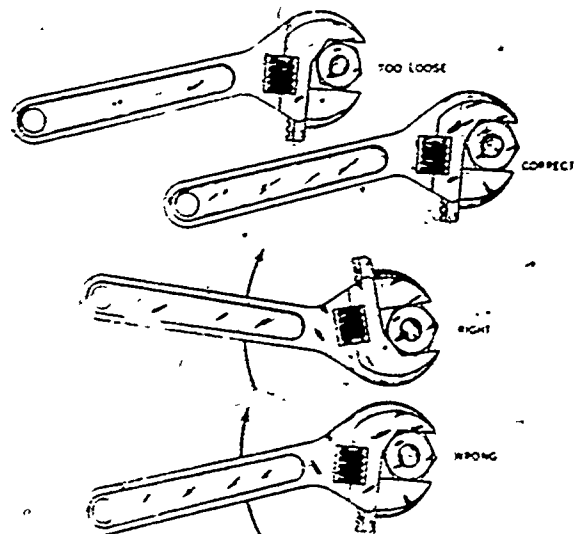


Figure 4-21. Adjustable end wrench.

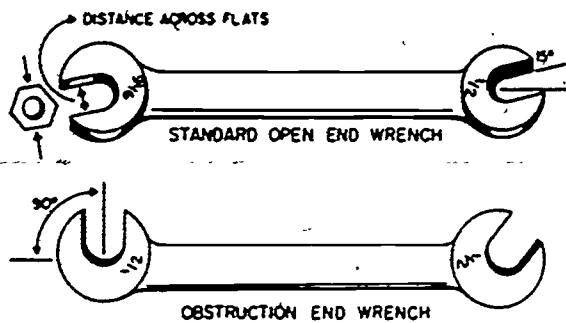


Figure 4-22. Open end wrench.

for much heavier cutting of larger wire and small cables. The various types of pliers that you normally use are shown in figure 4-24.

The combination slip-joint and water pump pliers are used extensively in electrical work. They are used to grip pipes and bolts.

Longnose pliers also serve many useful purposes. They may be used to bend any eye or loop in solid wire so that it can be wrapped around a bolt or screwhead. In places where you cannot get your fingers to tighten small size nuts or bolts, the proper application of the longnose pliers will be helpful. The longnose pliers are actually extensions of your fingers in many instances.

Pliers require an occasional light oiling at the pivot point or joint. Cutting pliers at times may become pitted at the cutting edge. Here again the proper application of a fine file over a pitted spot on the cutting edge is sufficient to restore its original condition. You can also use the fine file to sharpen the cutting edge of the diagonals or sidecutters if necessary.

The hinge or joint of water pump and slip-joint pliers may occasionally require a drop of oil and tightening of the hold nut. The knurled jaws or gripping teeth of these tools require cleaning for better gripping. Use a steel brush to clear out steel wastes, paints, and grease that have accumulated in the teeth or knurled jaws.

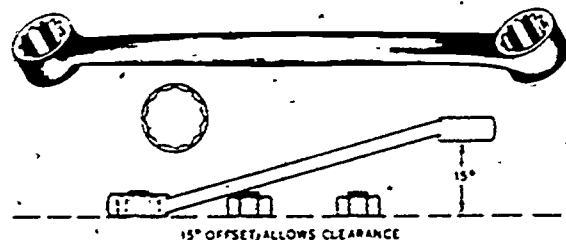


Figure 4-23. Box end wrench.

Exercise (049):

1. From the following list of common gripping tools in Column A match the tool to its proper use in Column B.

- | Column A | Column B |
|----------------------------------|---|
| 1. Pipe wrench | a. Cuts small electrical wire. |
| 2. Adjustable end wrench | b. Used on boltheads where limited room permits minimum movement. |
| 3. Open end wrench | c. Bends wire for eye or loop in solid wire. |
| 4. Box end wrench | d. Used for turning round rods. |
| 5. Socket wrench | e. Cuts heavy wire and cable. |
| 6. Combination slip joint pliers | f. Used for gripping electrical conduit. |
| 7. Longnose pliers | g. Used to fit various size boltheads. |
| 8. Diagonal pliers | h. Used where straight wrench cannot be used. |
| 9. Lineman's pliers | i. Used in hard-to-reach places on boltheads etc. |

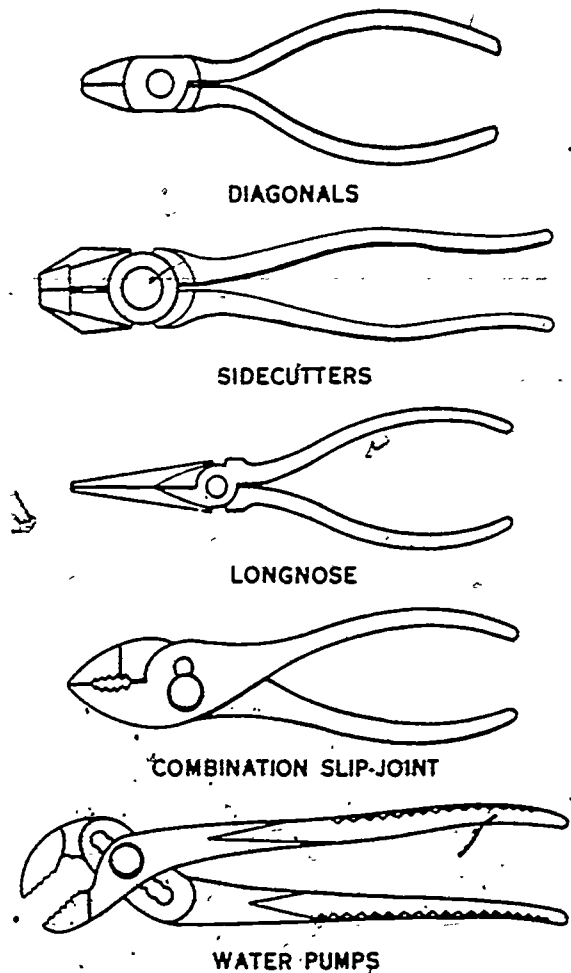


Figure 4-24. Types of pliers.

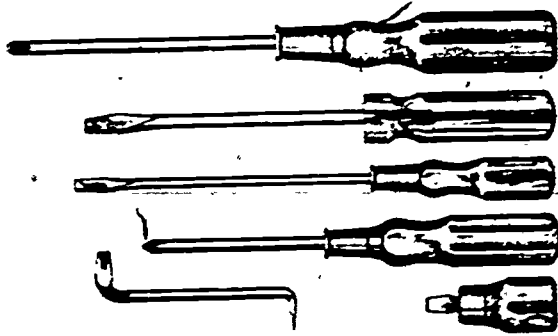


Figure 4-25. Types of screwdrivers.

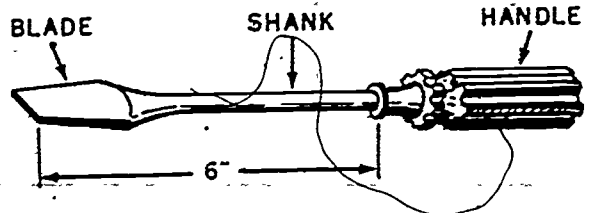


Figure 4-27. Sizing of screwdrivers.

050. State the types of screwdrivers, and tell how to repair screwdrivers.

The screwdriver is one of the most common handtools but because it is so common, everyone thinks he knows how to use it properly. It usually winds up being the most abused tool. Do you know that a screwdriver is meant only for driving and removing screws? It is not designed to be a chisel, punch, pry, nailpuller, or hammer. Jackknives, wirecutting pliers, and chisels have fairly sharp cutting edges—screwdrivers should not have, the point should be squared.

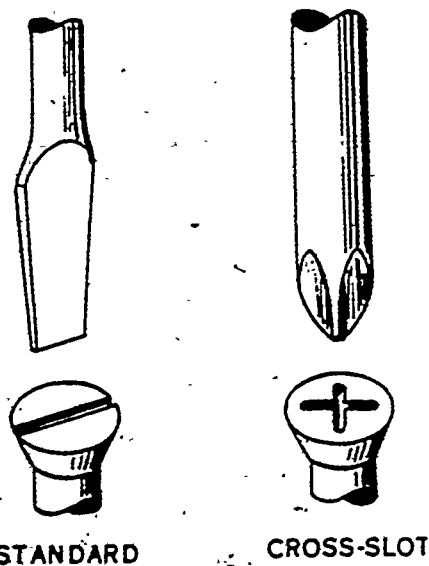
There are several different types of screwdrivers. However, the cross-slot or Phillips screwdriver and standard screwdriver are the types which are most popular with tradesmen. (Figure 4-25 shows commonly used screwdrivers.)

Each type is designed to fit a particular type screw, as shown in figure 4-26. Within each type there are several sizes. The sizes of the screwdriver increases as the size of the screw increases.

Screwdrivers are usually identified by size according to the combined length of the shank and blade. Measure the screwdriver from the base of the handle to the tip of the blade. This gives the screwdriver size. Common sizes are 3", 4", 5", 6", 8", 10", and 12". (See fig. 4-27.)

The Phillips screwdriver, or cross-point, comes in about the same sizes as the common screwdriver. You must apply the proper size to the screw, or you may damage both the screw and screwdriver.

The offset screwdriver is a very handy item for the heating specialist since you use it to turn screws at remote, hard-to-get-at angles. It has a shank about 5 inches in length, with blades on each end bent to about 1/2 inch. The blades are bent at 90° angles so that they can be used to reach remote locations. (Refer to fig. 4-28.)



STANDARD

CROSS-SLOT

Figure 4-26. Screwdriver blades.

The common screwdriver blade must be straight and have sharp corners which fit the screw slot firmly. You do not damage a screwhead if you use the right size screwdriver. Hold the screwdriver firmly against the screw to prevent it from slipping. Do not hold the screw in your hand while

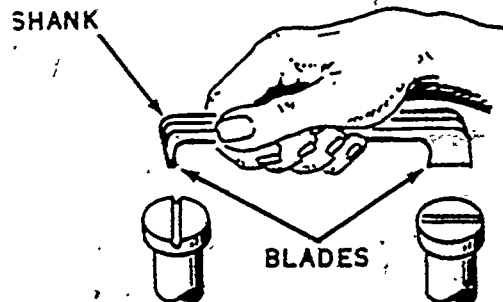


Figure 4-28. Offset screwdrivers.

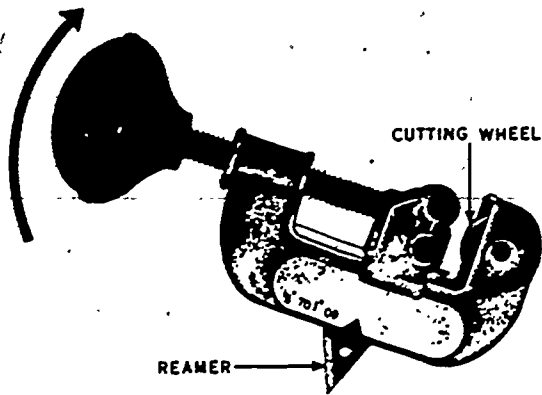


Figure 4-29. Tubing cutter.

applying pressure to tighten it. If the blade should slip, you could damage your work or seriously injure your hand. Always keep safety first and last in your mind. Never use a screwdriver as a chisel or pry bar because the tip is hard and may break.

When the blade tip becomes rounded or broken, you can usually restore it to the original shape with a bench grinder or file. When you grind a new tip on a screwdriver, do not get it too hot. Too much heat draws the temper from the metal and leaves the tip soft and worthless. To keep the screwdriver from lifting out of the screw slot, grind the sides of the blade almost parallel. It is good practice to slightly hollow the sides of the blade.

To remove nicks and to square the tip of a screwdriver, adjust the bench grinder rest to a position so that the screwdriver is at right angles to the grinding surface of the abrasive wheel. Next, adjust the rest to hold the

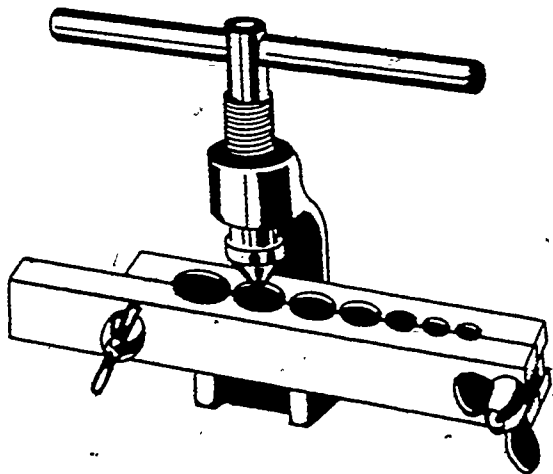


Figure 4-30. Flaring tool.

screwdriver against the wheel for a concave shape. Grind both sides until the tip is the right shape and thickness. Dip the tip in water frequently to cool it during the grinding. When the blade of a screwdriver is only slightly damaged or worn, use a common file to dress it. Use a vise to hold the screwdriver during dressing.

The Phillips screwdriver, or cross-point, must be treated in a different manner. In restoring the Phillips screwdriver to its original condition, apply a three-cornered file to remove any burrs that exist on the damaged blades. Due to the delicacy of its fine blades, the Phillips screwdriver has to be discarded whenever the blades are damaged beyond the filing point.

Exercises (050):

1. What are the types of screwdrivers used by the heating mechanic?
2. In repairing a standard screwdriver that has a nicked blade, what procedures would you use?
3. List the steps normally used in repairing a badly worn Phillips screwdriver.

051. Identify the proper tools to use for cutting, bending, and flaring copper tubing.

Tubing Cutter. The tubing that is used on heating systems can be cut with the tube cutter shown in figure 4-29. Tubing may be cut to exact length by placing the cutter wheel on the measured mark and turning the cutter slowly around the tubing. After each turn of the cutter, additional pressure (about 1/4 turn on handle) is applied to the cutter wheel until the tubing is cut. A sharp tube

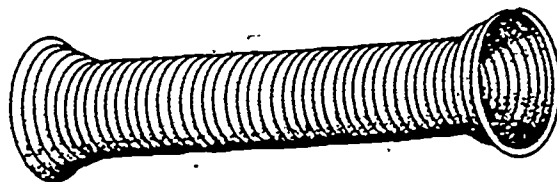


Figure 4-31. Tube bending spring.

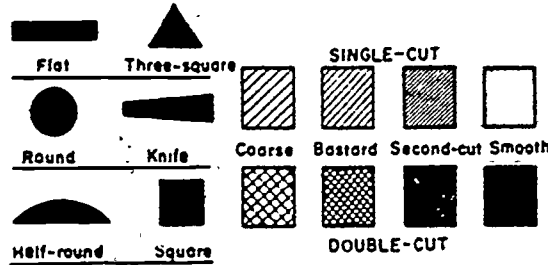
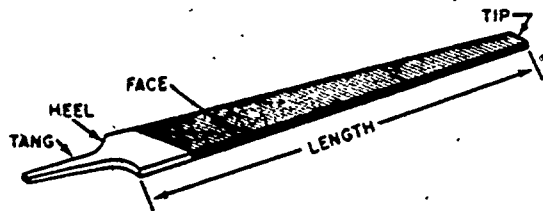


Figure 4-32. File.

cutter will leave little burring on the inside of the tubing; however, most cutters have a reamer as shown in figure 4-29. The reamer is used to smooth the inside of the cut.

Flaring Tool. A flaring tool (see figure 4-30) is used to make flares at the end of sections of tubing where flare nut connections are to be made. More will be said about flaring later in the course.

Tube Bending Spring. A tube bending spring may be used to bend tubing by hand when a high degree of accuracy is not required. These springs (see figure 4-31) come in all sizes and are made for both internal and external use. The internal spring is for use near the ends of the tubing or flared tubing, while the external is best used in the middle of long lengths of tubing. The purpose for using these springs is to prevent buckling of the tubing.

Exercises (051):

1. Tell which tools you will need to complete the following task: Install a fuel line (tubing) which will have a total length of 5 feet, flared connections at each end, and will have one 45° bend.

052. Identify the types of files and give the proper methods of using files.

Files and Filing. A file is a hardened high-carbon steel tool for cutting, removing, smoothing, or polishing metal. One file is shown in figure 4-32.

The cutting teeth of files are made by straight or diagonal row of chisel cuts. Various cuts are shown in figure 4-33. Files are classified by name, grade, and cut. The cut may be either single or double, such as those shown in figure 4-34. Grade refers to the distance between the parallel cuts. This can be listed in the order of coarseness as follows: flat, coarse, bastard, second cut, smooth, and dead smooth. Files are made in various shapes and they vary from 3 to 24 inches in length.

Types. Types of common files are mill, flat, round, hand, and half-round. The mill file is a single-cut file tapering in thickness and width for one-third of its length. It is useful for fine work and is available with square, round, or with smooth edges that have no cutting teeth. The flat file is a double-cut file that often tapers in thickness and width. It is used when a fast-cutting tool is needed.

The round file is a round tapered type having various cuts, but sometimes double cut in the larger sizes. It is sometimes referred to as a rattail file. Parallel or untapered round

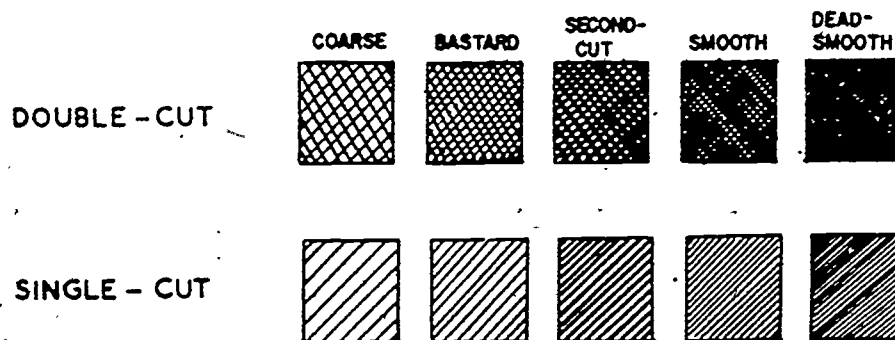


Figure 4-33. File cuts.

files are also available. The principal use of these files is to enlarge circular openings or form concave surfaces. The hand file is a single-cut file similar in shape to a flat file, but with parallel sides and only a slight taper in thickness. It has square edges, one which is a safe edge.

The half-round file is a double-cut file which tapers in thickness and width and has one flat and one oval side. This file is for removing stock rapidly and for filing concave surfaces.

Selecting files. Select the correct file for the work. The following points can be helpful in making your selection. For heavy, rough cutting, a large coarse double-cut file is the most suitable; for making finishing cuts, however, use a second-cut or a smooth single-cut file. Start filing cast iron with a bastard file and finish with a smooth file; however, when filing hard steel, start with a smooth-cut file and finish with a dead-smooth file. Start filing brass or bronze with a bastard file and finish with a second-cut or smooth file; however, use a flat file when filing aluminum, lead, or babbitt metal, and then finish with a second-cut or smooth file. For small work use a short file, for medium sized work an 8- or 10-inch file, and for larger work a file as large as can be controlled conveniently.

Using files. It is equally important for you to know how to use a file. Here are some points to be observed when working with a file. Hold the file with the handle against the palm of your hand, thumb on top, and the end of the file in the other hand with your fingers curled under it. When filing, lean your body forward with the weight evenly distributed on both feet. Hold the file straight or the surface of the work will not be flat. Not more than 30 to 40 strokes per minute should be taken; too much speed will ruin the file and the work. Use pressure only on the forward stroke, and apply only enough pressure to make the file cut evenly. Lift the file from the work on the return stroke to prevent it from becoming dulled by scraping action. (This does not apply when filing very soft metals, such as lead or aluminum. On soft work, pressure on the return stroke helps keep the file clean of removed metal.)

A file with a tang should never be used without a handle, as the tang may run into or cut the hand. Be certain the handle is wedged firmly on the tang of the file. Small files, such as needle and ignition files, have handles. Hold the work firmly in a vise, with the surface to be filed projecting slightly above

the vise jaws and parallel with them. If the work is loose in the vise, the file will chatter. This damages the teeth. It is poor practice to bear down hard on a new file. When the file is new the teeth edges are very fine and will not stand much pressure.

When round surfaces are filed, the best results are obtained by using a rocking motion as the file is moved across the work. To produce a very smooth surface, work is sometimes drawfiled. When drawfiling, move the file sideways along the work. A single-cut smooth file should be used. Pressure is heaviest on the stroke made toward the body and very light on the return stroke. For a smooth finished surface, wrap a piece of fine emery cloth around the file and proceed as in drawfiling.

Like all other tools, a file should be given good care while it is being used. Certain precautions should be carefully observed to get maximum results from filing. When filing soft metals, narrow surfaces, or working in corners, small particles of metal sometimes clog the teeth of the file and scratch the material being filed. This is called pinning. It is usually the result of putting too much pressure on the file, especially if it is a new one. To avoid pinning, be certain the file is "broken in" before taking heavy cuts. Also, rubbing chalk on the file before using it will help prevent pinning.

Break in a new file by using it first on brass, bronze, or smooth cast iron. Do not break a new file in on narrow surfaces such as sheet iron because the narrow iron is likely to break off the sharp points of the teeth. Never use a new file to remove the fins or the scale from cast iron. Most of the damage to new files is done by using too much pressure during the first few strokes.

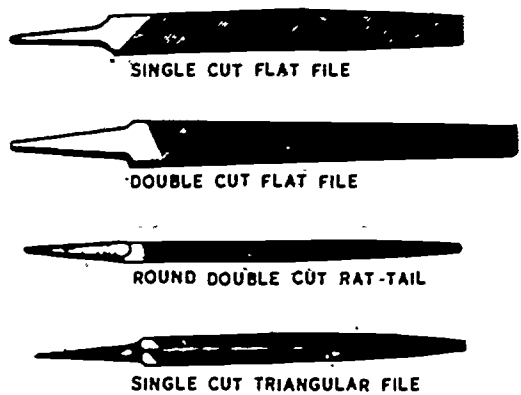


Figure 4-34. Various types of files.

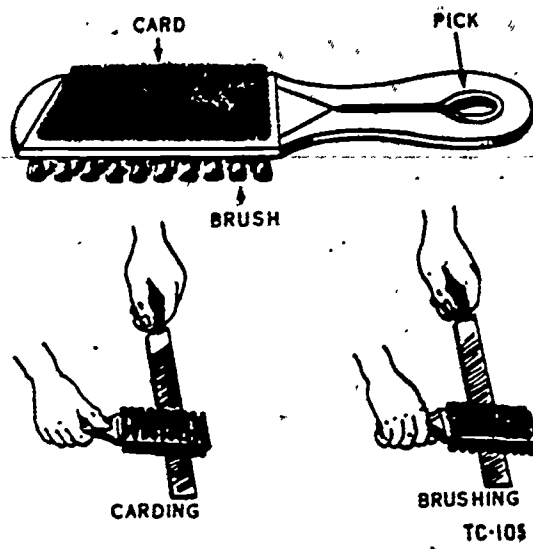


Figure 4-35. File card.

When a file is pinning and not cutting properly, it should be cleaned with a file card, pick, and brush, which are shown in the bottom view of figure 4-35. The pick is a small pointed wire instrument often furnished with a card file for cleaning out individual cuts in the file that are clogged too tightly with metal to be cleaned with a file card. When cleaning a file, lay it flat on the bench and draw the file card and brush back and forth across it parallel with the teeth cuts.

Never use a file on material harder than itself or on sandy or scaly castings. One stroke across this sand or scale will make the file useless. Apply a little oil on the surface of the file to lubricate the chips and to prevent scratching when filing wrought iron, steel, or hard fiber.

Like other cutting tools, files are easily dulled by rough or improper storage and handling. Do not throw files into a drawer or box where they can rub against each other or against other tools. Store them in separate holders such as clips, straps, or holes cut in a wooden block. For best results and long file life, use and store files properly.

Painful injuries can be caused by the improper use of files. The following suggestions will help you use files without personal injury. Firmly attach the handle on the file, particularly when filing work that is rotating in a lathe. Do not salvage a small rattail file for the purpose of using it as a prick punch for it is too brittle. Never use a file as a pry. It usually breaks and throws off tiny bits of steel which can get into your eyes.

Never use a file as a hammer; this will not only damage the file but can throw steel particles into your eyes.

Exercises (052):

1. From the types of files in Column A, match the file to its proper use in Column B.

- | | |
|---|---|
| <p><i>Column A</i></p> <ol style="list-style-type: none"> 1. Mill 2. Flat 3. Round 4. Hand 5. Half-round | <p><i>Column B</i></p> <ol style="list-style-type: none"> a. Used for removing stock rapidly. b. Used in various ways. c. Used for fast cutting. d. Used for fine work. e. Used for enlarging circular openings. |
|---|---|

2. Identify the following statements as being either true or false.

- 1. A minimum of 60 strokes per minute is recommended when filing.
- 2. Use pressure on both strokes for soft metal.
- 3. Use both hands when filing.
- 4. The tang of the file can be used as a pry for soft material.
- 5. Always bear down hard on a new file and use a soft metal as this forces the metal between the teeth and thereby strengthens the file.
- 6. Rubbing chalk on a new file will prevent pinning.
- 7. Coarse emery cloth is a good file cleaner.

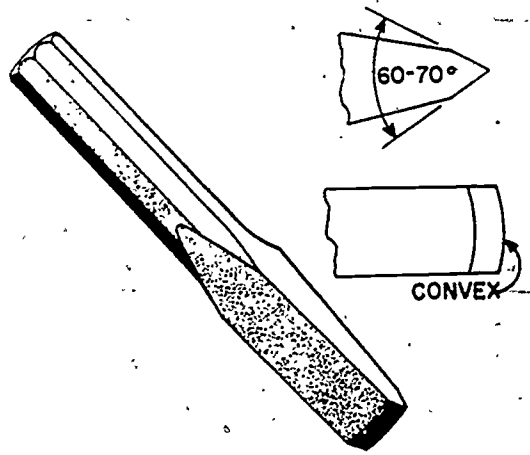


Figure 4-36. Cold chisel.

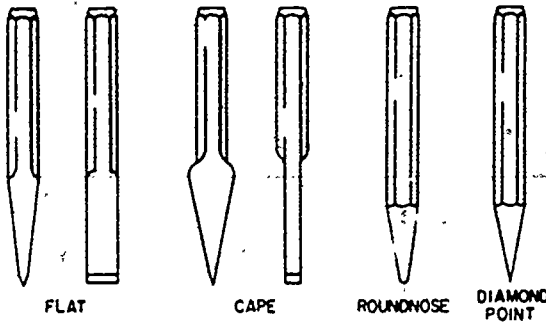


Figure 4-37. Types of cold chisels.

053. Cite the purpose of chisels, punches and hammers.

Cold Chisel. A flat cold chisel is a tool which you will use quite often, especially to cut metal and boiler tube. (See figure 4-36.) Keep your chisel sharp and the edge ground at the proper angle. The cutting angle is determined according to the hardness and softness of the metal being cut. A cutting edge angle of 70° does well for most light metal. There are various types of cold chisels. (See figure 4-37.)

Chisels used on hard or tough metal require greater strength backing up the cutting edge; an angle up to 90° may be used for this purpose. The cutting edge can be decreased somewhat from 70° for cutting softer metals.

To grind a chisel, set the rest on the grinder to secure desired bevel angle. Move the chisel head from side to side a little during grinding to slightly curve cutting edge. Turn the chisel over to grind other bevel. Keep the bevels the same size or the cutting edge will not be centered. Dip the chisel frequently in water to preserve its temper.

It is dangerous to use a metal cutting chisel with a mushroomed head. Grind head to

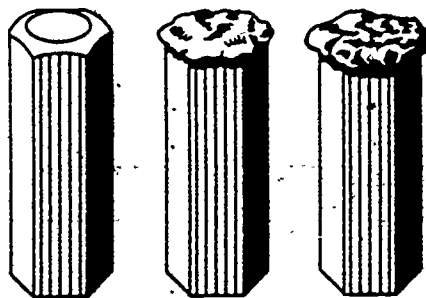


Figure 4-38. Examples of mushroomed and properly dressed cold chisels.

original shape (see figure 4-38). Harden chisel after removing mushroom.

Overheating the chisel during the grinding process causes the chisel to lose a great amount of hardness; therefore, it will be necessary to retemper the cutting and head ends of the chisel. To temper, heat whole chisel to cherry red in a gas furnace or with an acetylene torch. Grasp chisel in center with tongs. Dip cutting end in clear, cold water to a depth of about 1¼ inches. Turn chisel over and dip head end about 1 inch.

Hammers. Hammers are made in varying sizes and shapes. You may find that you use the claw hammer and the ball-peen (machinist's) hammers more than the other types. Figure 4-39 shows the hammers you should be acquainted with.

A claw hammer is used to drive or pull nails in wooden construction. Always keep the hammer face clean to prevent slipping, which causes a nail to bend. Hammers should be held near the end of the handle with the face of the striking surface parallel to the work. A grip just tight enough to control the tool is best. Deliver blows upon the object to be struck with a quick, sharp wrist action if the object is small. Use a wrist, elbow, and shoulder action on larger objects. The weight of the head of the hammer designates its size. The claw hammer runs in sizes from 7 to 22 ounces. The 16-ounce size is the most common.

The ball-peen hammer is used mainly in mechanical and shop work. Use it with driving and cutting tools, such as punches and chisels. The manner in which you use a ball-peen is the same as for the claw hammer.

Center Punch. A center punch is a tool with a point taper ground to an angle of 90°.

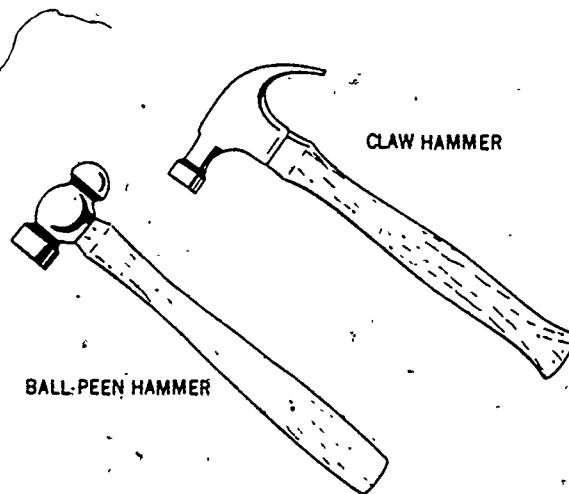


Figure 4-39. Ball-peen and claw hammer.

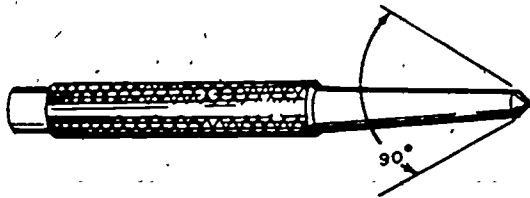


Figure 4-40. Center punch with correct angled point.

(See figure 4-40.) A center punch mark is used to start the drill for holes that are to be drilled in metal. If you try to drill a hole without first punching the center, the drill will "wander" or "walk away" from the desired center. A center punch point is ground to cone shape. For best results the correct point angle is about 90 percent.

To grind the center punch point to the correct angle, adjust the grinder rest so the punch meets the wheel at the desired angle. Rotate the punch during grinding to make the point symmetrical. Dip the punch in water at frequent intervals to avoid burning. Do not grind away more material than necessary to secure a satisfactory point.

Exercises (053):

1. What affects your decision to use a cold chisel with a cutting edge of 70° rather than one with a 90° angle?
2. What is a center punch used for?
3. When will you as a heating mechanic have to use a cold chisel?
4. What other type tool do you use with a center punch?

054. Identify the types and uses of the different cutting tools.

Hacksaw. Hacksaws (figure 4-41) are used for sawing metals and hard plastic materials. Common hacksaws may have either solid or adjustable frames. Adjustable frames can be changed to hold various sized blades, from 8

to 16 inches in length. Solid frames, although more rigid, take only the blade for which they are designed. The length is the distance between the two pins which hold the blade in place in the frame. Most hacksaw frames are designed to permit the rotation of the blade to a right-angle position for cutting deeper than the frame would otherwise allow.

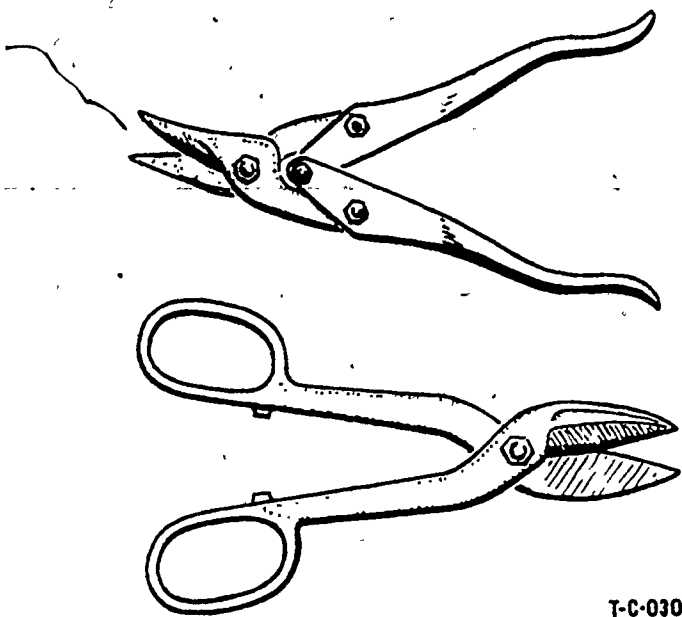
As you may already have deduced, hacksaws are made in two pieces—a frame and a removable blade. This is quite necessary since the blade does not last for many cuts before it wears out or the teeth strip off. The blades most generally used are of two types—the all-hard and the flexible. The all-hard blades are hardened throughout, while only the teeth of flexible blades are hardened. A particular feature to remember is that blades vary in the size of the teeth, ranging from 14 to 32 teeth per inch. You use the one with the correct amount of teeth for the type of cutting you are doing.

Selecting the best blade for a specific job is a twofold task: first is the question of whether to use an all-hard or a flexible blade; second, you should determine the number of teeth per inch that will do the best job of cutting. The rules listed below help acquaint you with some of the answers to the two problems.

- a. An all-hard blade is best for sawing brass, tool steel, cast iron, and other stock of heavy cross section.
- b. In general, you use a flexible blade for sawing hollow shapes and metals of light cross section, such as tubing, pipe, sheet iron, or copper.
- c. Use a blade with 18 teeth per inch on machine steel, cold-rolled steel, or structural steel. The coarse pitch makes the saw free and fast cutting.
- d. For solid stock aluminum or cast iron, you use a blade with 14 to 18 teeth per inch. This size is recommended for all general use.
- e. Use a blade with 24 teeth per inch on brass and copper tubing, and on steel conduit. Two or more teeth should be in contact with the work to preclude stripping of the teeth.



Figure 4-41. Hacksaw frame.



T-C-030

Figure 4-42. Metal shears.

f. In general, use a coarse-toothed blade for sawing soft metals and a fine-tooth blade for sawing hard metals.

After you select the correct blade, insert it in the frame with the point of the teeth pointing away from the saw handle. With the blade inserted in the frame, sawing is done by moving the saw forward with a light steady stroke. At the end of the stroke you relieve the pressure and draw the blade straight back. After the first few strokes, make each stroke as long as possible without striking the saw frame against the work.

Shears. Shears, or tin snips as they are sometimes called, are illustrated in figure 4-42; they are useful in cutting lightweight sheet metal, gasket stock, and other materials that are easily cut by shearing action. They should never be used to cut wire or rod stock, because this use will probably damage the cutting edge of the blade. Ordinary shears are

usually issued in 6- and 12-inch sizes. The most commonly used shears are the straight blade type. The curved blade type is used to cut circular shapes. Shears are usually sharpened with a power bench grinder. Keep the shears clean and the pivot pins well oiled.

Exercises (054):

1. Match the types of hacksaw blades in Column A to the metals they should cut in Column B.

Column A

Column B

- | | |
|-------------------------|--------------------------|
| 1. All-hard blade | a. Hollow shapes. |
| 2. Flexible blade | b. Solid stock aluminum. |
| 3. 18 teeth per inch | c. Brass. |
| 4. 14-18 teeth per inch | d. Copper tubing. |
| 5. 24 teeth per inch | e. Hard metals. |
| 6. Coarse-toothed blade | f. Structural steel. |
| 7. Fine-toothed blade | g. Soft metals. |

2. List the types of shears and their uses.

055. State the uses and proper care of tapes, rules, and levels.

Rules and Steel Tapes. Rules or tapes are very important to any tradesman. In fact, as a rule, it should be carried by a heating mechanic at all times. There are several different types of folding rules. (See figure 4-43.) The 6-foot folding rule is generally used by the heating mechanic; however, some tradesmen prefer to use the 6- or 10-foot flexible rule. The heating mechanic must work carefully when unfolding the rule to prevent cracking or breaking the joints. If the joints become hard to operate, place a few drops of oil on each joint and remove excess oil with cloth. If the joints become excessively worn, you must be very careful or the joint will break when unfolding. Keep rule

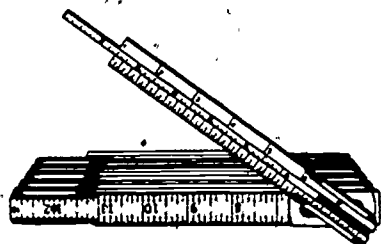


Figure 4-43. Folding rule.

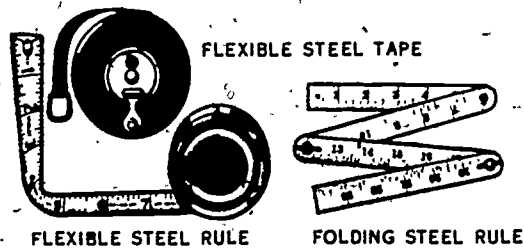


Figure 4-44. Steel measuring tools.

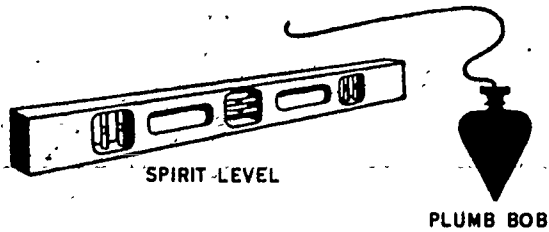


Figure 4-45. Level.

clean and protect the numbers at all times. A rule that has numbers that are not visible slows work progress.

Flexible steel rules and tapes are used by the heating mechanic to measure short and long lengths of pipe or when laying out a job. (See figure 4-44.) These flexible steel measuring tools must be kept clean and dry. Any dirt or sand on them tends to wear away the numbers and rust the steel. You must be careful when using the measuring tools to prevent kinking. A rule with a kink will not operate correctly. The bent part rubs against the case that holds it.

Level. The level, one type of which is shown in figure 4-45, is used to determine either the horizontal or vertical trueness of your work. The frame of the level is made either of wood or of aluminum. In the frame are glass tubes which contain air bubbles and a liquid. The tubes for horizontal and vertical leveling are marked to indicate their center and are aligned with the edge of the frame so that the bubble will be centered in the tube whenever the frame is level. The level is used for setting batterboards, digging ditches, and installing fixtures. The glass tubes are easily broken; so do not handle the level carelessly. Keep the level clean and well protected in your toolbox.

Exercises (055):

1. Why should the heating man carry a tape or rule with him on the job?
2. Proper care of tapes and rules consists of what?
3. Levels are used by the heating specialist to _____

4. The care of levels is extremely important because _____

056. State the facts one must know before using soldering irons or guns.

Soldering Devices. Soldering guns and irons are another convenience which industry has provided to increase the heating mechanic's production. Both types of soldering devices come in different lengths and sizes. It is important that you consider the type of job to be done before selecting an iron or gun. A large size may either ruin or burn up the appliance or device being soldered. A small size may not produce enough heat. All soldering irons and guns are rated in watts. The larger the wattage rating, the more heat produced. Soldering irons, and guns have cords of varying lengths and all operate from 120 volts ac. Most soldered terminals or joints are made with rosin-core solder. Notice the three different soldering devices in figure 4-46.

Shape and clean the points on soldering devices either by filing or using steel wool. The point must be kept clean at all times for the correct application of solder. Never dip an electric soldering iron in water. If the iron does not heat when plugged into a live circuit, this may indicate an open circuit in either the

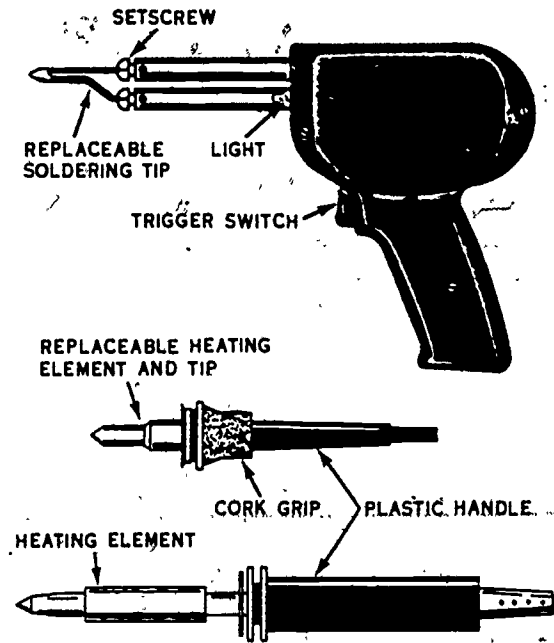


Figure 4-46. Soldering guns.

cord or the heating element. Visually inspect the cord to check for breaks in the insulation. If the open circuit cannot be located by visual inspection, disconnect the cord and element separately. Do not leave electric soldering irons or guns plugged in for long periods of time on the chance that they may be needed. This practice is hard on the element and a waste of current. Always disconnect electric soldering irons and guns when they are not in use. Soldering guns have replaceable tips that vary in size. Maintenance of these is simple; the tip is removed and replaced in one operation.

Exercises (056):

1. What important point must you remember when you apply solder?
2. What important facts must the heating specialist know before he starts to solder?

057. State the procedures for caring for tools.

Procedures for Cleaning. Each tool that is used by the heating mechanic on the job must be cleaned after its use. It is always good practice for the mechanic to be well supplied with cleaning rags or cotton waste.

The procedure for cleaning tools is determined to a great extent by where the tool is used; that is, if the tools were used in the sewer ditch, cleaning will present more of a task than if the tool has been used on the shop workbench.

Dirt, water, and oil must be cleaned from the tool after its use or at the end of the day. If the tool has been exposed to water or mud, it is important that the tool be cleaned immediately after it is used. This cleaning process will prevent the tool from rusting so easily. If mud is allowed to dry on the tool, it becomes difficult to remove. It is often necessary to use water on some types of tools to remove dry caked dirt. If this process is used, it is important that you coat the metal part of the tool with oil before you store it away for the day or job. On some tools it is never advisable to use water to clean them because of the damaging effect to the tool. In this case, it is better to use some type of solvent, such as trichloroethylene, but only if

45
it is applied in an open area that has good ventilation.

There are other general and special shop tools such as large pipe wrenches, chain tongs, shovels, picks, and power-driven machines which you will use from time to time. Tools of this type are not usually personal tools; however, you will share the responsibility of their care and maintenance with others. Always clean these tools when you are through using them and be sure that they are in good working order and stored in their proper places. The way you care for these tools, as well as your own, will be a good indication of your ability.

Repair, Sharpen, and Care. There are several approved methods of repairing and sharpening tools. One of the first methods of sharpening tools was to use a flat sandstone rock. This rock was rubbed over the cutting edge of the tool. The first large grindstones were mounted and hand-turned or foot-powered. These were used for sharpening axes, hatchets, and other chopping tools. Today we have power grinders, files, and oilstones. All of these sharpening devices are used to sharpen precision tools. Since the maintenance of all tools is important to the mechanic, the care of individual tools is presented in the following paragraphs.

Techniques Used in Lubricating. Requirements for lubricating should be recorded on preventive maintenance checklists and service records for every piece of operating equipment that requires grease or oil as a lubricant. The manufacturer's maintenance and operation instructions will be studied to determine where and when to lubricate and what kind of lubricant to use. Information should be included on the preventive maintenance records regarding lubrication points on each unit of operating equipment, the type of greasing device at each point, the type of lubricant recommended for each point, and the frequency of lubrication. Tools that do not have operating parts should be lubricated at times to prevent rusting, especially when they are placed in storage for even a short period of time.

Tools and equipment that have operating parts should be lubricated as needed. The procedure for lubricating the part is determined by the construction of the equipment. Some power equipment has a connection for a grease gun and some have cups for applying oil with an oil can. Other equipment is lubricated just by applying the oil to the moving part. One point to keep in mind is not to overlubricate; do not apply

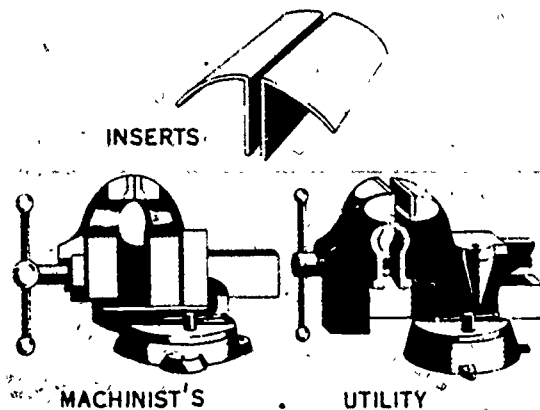


Figure 4-47. Vises.

grease or oil to such an extent that it will run out of the unit and collect dirt and grit. If an excess amount of lubricant is applied, remove it with a cloth. It is important to lubricate a moving part as often as necessary and it is also important that excess amounts of oil or grease be removed for reasons of cleanliness.

Small tools that are to be stored for any period of time must be coated with a thin layer of lubricant to prevent rusting. Metal parts of tools should be cleaned to remove fingerprints before they are coated with oil. Handling tools will cause them to rust if they are not cleaned before they are coated with oil. A good way to oil tools before they are stored is to apply the oil with an oily rag. Most generally these oily rags have been saturated in a light grade of engine oil (SAE #10). Where tools are to be stored for a long period of time, rust preventive should be applied to the metal parts of the tools. It is good practice to apply linseed oil to the wood part of tools if they are stored for a period of time. The linseed oil will soak into the wood preserving it. It will also prevent excessive water from entering the wood when the tools are exposed to water while in use.

When tools are stored for a long period of time, the box in which the tools are stored should be placed off the wood or cement floor so air can circulate under the box.

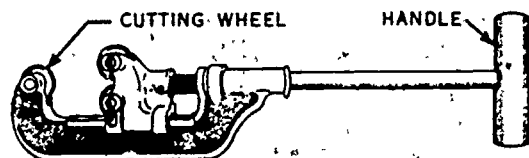


Figure 4-48. Pipe cutter.

Dry circulating air will keep down the moisture content which will help to prevent rusting of the tools.

Refer again to learning objective 049 for more information on the selection, use, and care of mechanic's handtools.

Exercises (057):

1. Who has the responsibility for cleaning tools?
2. Proper maintenance is important to the overall life of tools. What does proper maintenance consist of?
3. After tools are cleaned, oiled, and stored in a clean toolbox, what is the next step that should be accomplished?

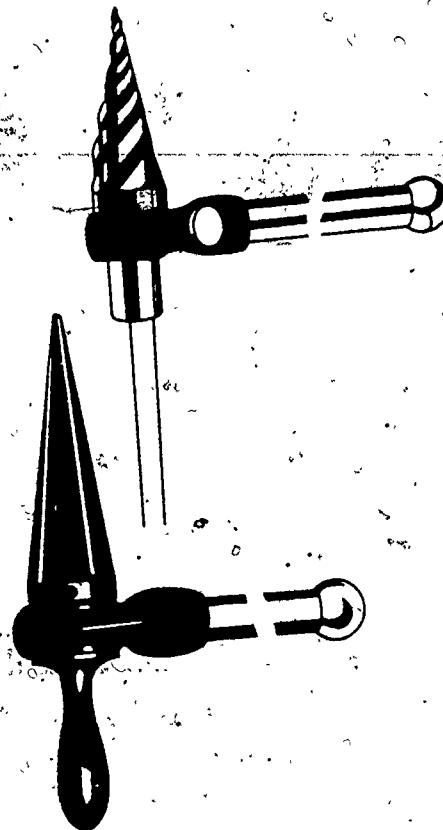


Figure 4-49. Pipe reamers.

4. Why should tools be wiped clean before oil is applied to them?

4-4. Scope of Portable and Shop Equipment

Shop tools are generally large tools that are used frequently but are too bulky and cumbersome to transport from one job to another in a toolbox. They are usually stored in a toolroom and must be checked out for use. Some of the more important shop tools are covered in this section.

058. State the types and uses of portable and installed shop equipment.

The following tools (equipment) are devices you may be responsible for.

Pipe Vises. There are several types of vises that the heating mechanic may use when cutting or threading pipe. Figure 4-47 illustrates two types that can be mounted either on a shop bench or on portable legs and carried to the job.

Vises require very little maintenance other than keeping them clean and the movable

parts well oiled. Do not use the jaws of a vise as an anvil. There is a danger of breaking the jaws or battering the inserts. Never use a pipe to increase the handle leverage, because excessive pressure on the handle may break the handle or jaws.

Pipe Cutters. Pipe cutters, as shown in figure 4-48, are available in several sizes. The size is usually indicated on the frame of the cutter. A pipe cutter with a range from 1/8 to 2 inches will handle most requirements on the job. Cutters for pipe over 2 inches in diameter usually have two handles to allow two men to rotate the cutter on the pipe. As for maintenance, keep the wheel pins and the threads on the shaft of the handle well oiled. When the cutting wheel becomes dull, you should replace it with a new wheel. Keep the tool clean at all times.

Pipe Reamers. The pipe reamer, two of which are shown in figure 4-49, is used to remove burrs from the inside edge of a pipe that has been cut with a pipe cutter. The metal is turned in by the pressure of the cutting wheel and must be removed to prevent restriction to the flow through the pipe after it is installed. Always ream the ends of a pipe when it has been cut by a pipe cutter. Do not store the reamer in a position that may cause the cutting edges to become

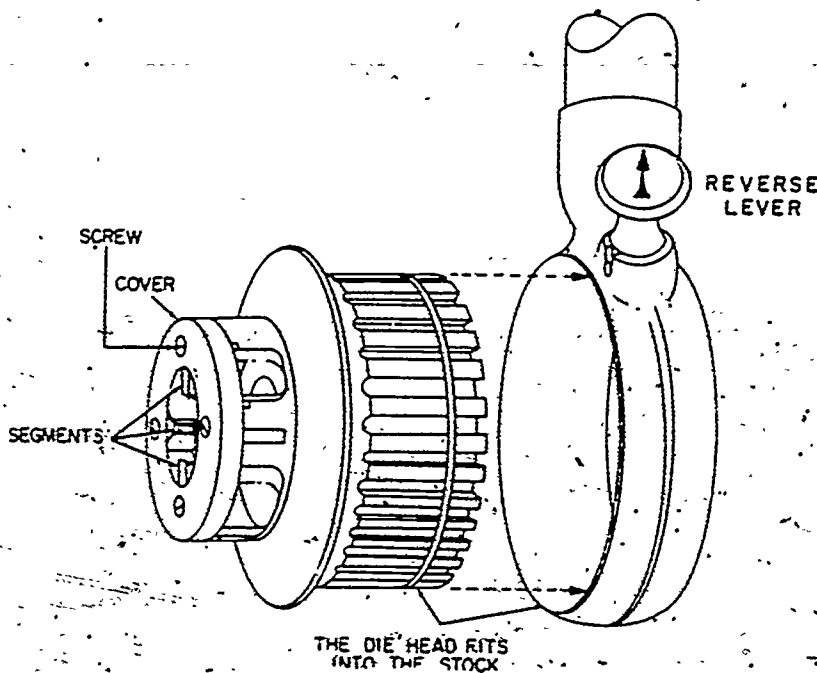


Figure 4-50: Ratchet pipe threader.

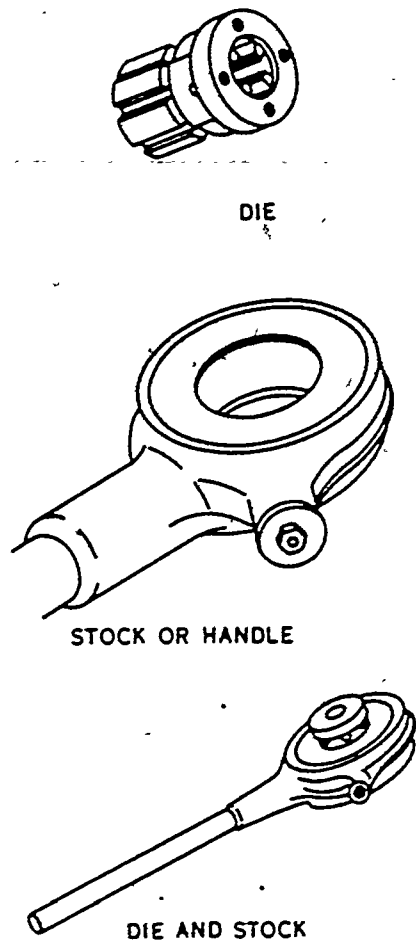


Figure 4-51. Die set.

dull. If the reamer is equipped with a ratchet, it should be kept clean and well oiled.

Pipe Dies. Pipe dies are used to cut threads on pipes. They vary in size. The die set, illustrated in figure 4-50, is used to cut threads from 1/8 to 2 inches. Larger pipe dies may be geared to cut threads on pipe up to 12 inches in diameter.

A die set consists of a stock or handle, a holder or frame, and a set of dies for different sizes of pipe. Most die holders are designed with a ratchet mechanism to facilitate thread cutting. (See figure 4-51.)

Dies are cutting tools and must be handled properly, because they are easily broken. This is due to their brittleness and hardness. Do not attempt to cut threads on hardened material, because it will break, chip, or dull the die. Keep the work well oiled when you are cutting threads on pipe and, when you finish, clean out the chips of metal sticking to

the die. Be careful of the sharp slivers cut from the pipe threads. Store the dies in a metal case.

Tube Bender. The tube bender is designed to shape and form smooth bends in soft copper tubing and pipe without collapsing the pipe. Figure 4-52 illustrates a small hand tube bender. This tube bender is normally used to bend pipe up to 1/2-inch diameter.

Bends in steel must be made so the pipe will not collapse. Powered tube benders are considered the most practical way to bend steel pipe.

Tube benders for steel pipe are manufactured in many different sizes and types. Powered tube benders should be used for bending steel pipe, because they make accurate smooth bends and do not kink, wrinkle, or crush the pipe. Steel pipe is marked and placed in the tube bender, and the bend is made in the same manner as for any other type of pipe or tubing.

Bench Grinder. The bench grinder, shown in figure 4-53, is a tool used for such handgrinding operations as sharpening chisels, and screwdrivers, drills, and punches; removing excess metal from work; and smoothing metal surfaces. It is usually fitted with both medium- and fine-grain abrasive wheels. These wheels may be removed and other wheels substituted for them. Such wheels may include wire brushing wheels, buffing wheels, or polishing wheels.

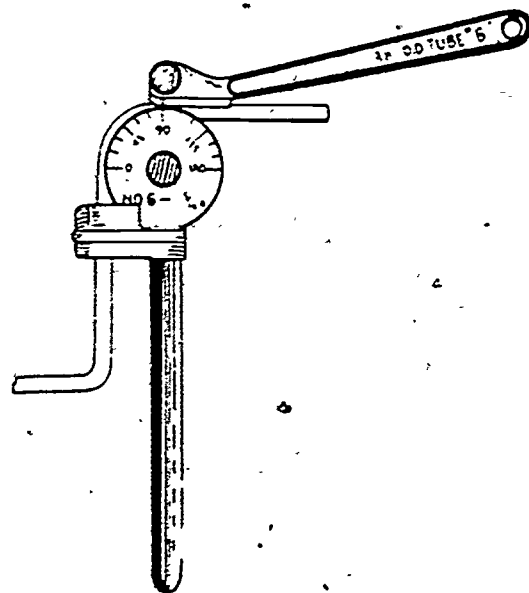


Figure 4-52. Tube bender.

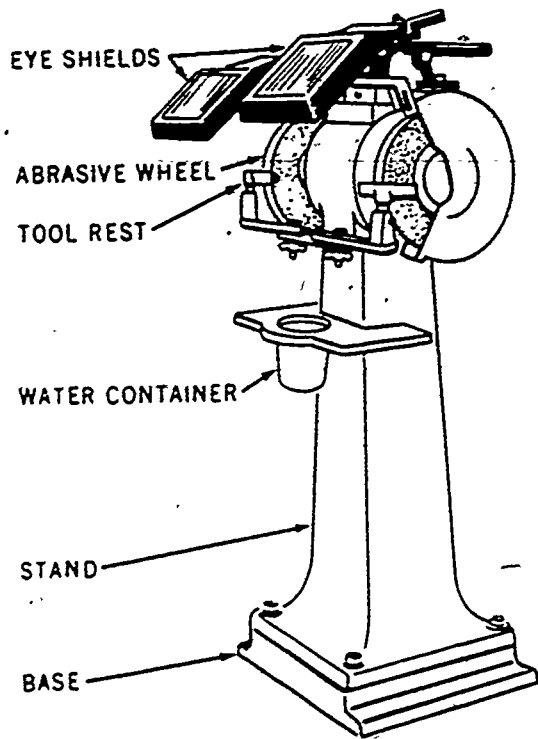


Figure 4-53. Bench grinder.

Before you use a bench grinder, make sure that the wheels are firmly held on the spindles by the flange nuts and that the tool rests are tight. Wear goggles, even if eyeshields are

attached to the grinder. It is unsafe to use a grinder without wheel guards. Remember, the abrasive wheel which grinds metal easily grinds human fingers more easily. The work should be held firmly at the correct angle on the tool rests provided on the grinder and fed into the wheel with enough pressure to remove the desired amount of metal without generating too much heat. Occasionally, cool the edges of the tools being ground to prevent drawing of the temper.

Exercises (058):

1. What is considered "shop" equipment?
2. List the components of a die set.
3. What is a shop bench grinder used for?
4. What sizes do pipe die sets come in?
5. What is the tube bender designed for?
6. Which process do you *not* practice when using a vise?

Bibliography

Department of the Air Force Publications

AFR 91-7, *Heating*, 27 May 1971.

AFM 85-12, *Operation and Maintenance of Central Heating Plants and Distribution Systems* (Volume 1), 1 June 1964.

NOTE: None of the items listed in the bibliography above are available through ECI. If you cannot borrow them from local sources, such as your base library or local library, you may request one item at a time on a loan basis from the AU Library, Maxwell AFB AL 36112, ATTN: ECI Bibliographic Assistant. However, the AU Library generally lends only books and a limited number of AFMs. Classified publications, and other types of publications are not available.

** Pg 51 have been omitted due to deleted material. No pertinent info. was left out.



ANSWERS FOR EXERCISES

024 - 1. Insuring your plant is properly ventilated is a form of good housekeeping.

024 - 2. Five practices that are considered good working habits are:

- a. Keeping working areas well lighted.
- b. Using care in disposing of scrap metal.
- c. Providing suitable waste containers.
- d. Keeping work area clean of debris.
- e. Using proper methods when moving tool- (See pg. 53.)

- boxes, etc., which are too heavy to handle conveniently.
- 024 - 3. "Goosing," if applied to a nervous person, may cause him to leap into moving machinery or into contact with high voltage electricity or he may simply fall and break a limb.
- 024 - 4. Five habits that are considered unsafe acts are: horseplay, working on machinery while it is running, working in a poorly ventilated area, leaving tools scattered around the work area, and working with machinery that is not properly guarded.
- 025 - 1. The main objectives of ground safety are to reduce accidents throughout the Air Force, to insure that every Air Force member carries out and adheres to all safety policies and procedures and to prevent accidents before they happen.
- 026 - 1. The *Electrical Facilities Safe Practices Handbook* (AFP 85-1) would probably be most available to you while performing on the job.
- 026 - 2. A newly assigned individual can expect to be given safety orientation by his section supervisor.
- 026 - 3. AFM 127-101, *Industrial Safety Accident Prevention Handbook*.
- 027 - 1. The most common types of injuries are wounds, fractures, burns, shock, and injuries caused from toxic substances.
- 027 - 2. Emergencies resulting from toxic substances are burns, poisonings, and suffocations.
- 027 - 3. The symptoms of shock are: trembling, rapid pulse, excessive thirst, gasping for air, paleness, excessive perspiration, and possibly becoming faint.
- 027 - 4. The three lifesaving steps are: stop the bleeding, prevent shock, and protect the wound.
- 027 - 5. Using a tourniquet is a lifesaving measure to perform on a person with a "gushing" wound that won't stop.
- 027 - 6. The fundamental first aid measure to perform for electrical shock is to administer artificial respiration.
- 027 - 7. The throat on either side of the windpipe near the collarbone is the location of the strongest pulse sensation.
- 028 - 1. The common methods of artificial respiration are: mouth-to-mouth, back-pressure arm-lift method, and the back-pressure hip-lift method.

Mouth-to-mouth is the preferred method; it should be used in most cases. However, the other two methods should be used if the victim has mouth injuries or is vomiting. The back-pressure hip-lift method can also be used if the victim has arm injuries.

- 028 - 2. Heart-lung resuscitation is a combination of artificial respiration and a closed chest cardiac massage, which is a first-aid measure taken in cases of shock, heart failure, drowning, suffocation, etc.
- 028 - 3. 1. Artificial respiration (mouth-to-mouth).
 - a. Patient must be faceup.
 - b. Mouth must be free of foreign matter.
 - c. Head must be in correct position.
 - d. Must be no air leakage from patient.

- e. Correct amount of breath should be forced into victim's lungs.
- f. Maintain correct breathing rate.
- g. Be alert of excess amount of air being forced into victim's stomach.
- h. Be alert to possible relapse.
- 2. Closed chest cardiac massage.
 - a. Patient must be on solid support.
 - b. Pressure should be applied only at correct area.
 - c. Correct amount of pressure should be applied.
 - d. Maintain pressure rate of approximately 60 thrusts per minute.
 - e. Artificial respiration should be performed at same time or alternately.
 - f. Both measures should be performed for an unlimited amount of time.

- 029 - 1. The severity of an accident is determined by the resulting disability classification.
- 029 - 2. The disability classifications used are: fatal injury, permanent total disability, and permanent partial nondisabling injury.
- 029 - 3. All accidents, no matter how big or small, must be reported.
- 030 - 1. AFR 127-4, *Investigation and Reporting US Air Force Accidents and Incidents*.
- 030 - 2. AF Form 711, USAF Accident/Incident Report, and AF Form 711a, Ground Accident Report.

CHAPTER 4

- 044 -1. Blueprints are derived from mechanical drawings which are drawn to scale.
- 044 -2. The negative of a blueprint is called a tracing.
- 044 -3. There are four main steps in making a blueprint.
 - (1) Make a mechanical drawing to scale.
 - (2) Trace the drawing on a special translucent paper.
 - (3) Mount tracing on a sensitized blueprint paper and expose it to a strong penetrating light, which causes a chemical reaction to the exposed part of the paper.
 - (4) Wash the print in clear water to remove the unexposed chemical.

- 045 - 1. There are five common types of prints: (1) blueprint, (2) Vandvke, (3) BW prints, (4) ozalid prints, and (5) photostat prints.
- 045 - 2. The ozalid print is dried with ammonia vapors in a developing machine.
- 045 - 3. The photostat print eliminates some procedures because of the photograph taken of the drawing.
- 046 - 1. The medium weight line on a blueprint drawn from a water heater would represent a run of pipe.
- 046 - 2. The symbols _____ X _____ and T refer to a thermostat.
- 046 - 3. Water lines and steam lines are illustrated by using object lines or visible lines.
- 047 - 1. The purpose of scaling is to either reduce prints so their size can be placed on smaller sheets of paper without crowding the views or enlarge prints so small objects can be clearly represented.
- 047 - 2.
 - 1. c.
 - 2. b.
 - 3. a.
 - 4. d.
- 048 - 1. Elevation views are pictures of an object viewed from the front of all four sides. Plan views are blueprints of the interior of a building. Plans are made so that the viewer looks downward from a point directly above.
- 048 - 2. Normally, you would use a plan view while plumbing a house.
- 049 - 1.
 - 1. d.
 - 2. g.
 - 3. h.
 - 4. b.
 - 5. i.
 - 6. f.
 - 7. c.
 - 8. a.
 - 9. e.
- 050 - 1. Cross-slot, standard, and offset.
- 050 - 2. To remove nicks in a standard screwdriver, use a bench grinder. Hold the screwdriver on the rest at a right angle to the abrasive wheel, next using the rest, grind the screwdriver for a concave shape. Grind screwdriver on both sides until the right shape and thickness is accomplished.
- 050 - 3. When a Phillips screwdriver is badly worn, replace it with a new one.
- 051 - 1. The tools necessary for this project are a tape measure, tubing cutter, tube binding spring, and a flaring outfit. Measure tubing to correct size (5 feet). Cut tubing by placing cutting wheel on measured mark, apply light pressure. Revolve cutting wheel around tubing, applying additional pressure with each revolution, until the tubing is cut. Ream tube ends to insure there are no burrs on the inside. Use the tube bending spring to make a 45° angle with no kinks or flattened spots.
- 052 - 1.
 - 1. d.
 - 2. c.
 - 3. e.
 - 4. b.
 - 5. a.

- 052 - 2.
 - 1. F.
 - 2. T.
 - 3. T.
 - 4. F.
 - 5. F.
 - 6. T.
 - 7. F.
- 053 - 1. The softness or hardness of the metal in which you are cutting.
- 053 - 2. To make a mark in starting drills to insure they don't "wander" away.
- 053 - 3. When cutting boiler tubes.
- 053 - 4. A hammer. Specifically a ball-peen hammer.
- 054 - 1.
 - 1. c.
 - 2. a.
 - 3. f.
 - 4. b.
 - 5. d.
 - 6. g.
 - 7. e.
- 054 - 2. The common types of shears are the straight blade and curved blade. They are used for cutting lightweight sheet metal, gaskets, etc. The curved blade is used primarily in cutting circular shapes.
- 055 - 1. The heating man should carry a measuring device, because on occasions he will measure lengths of pipe for a repair job or be required to lay out a job.
- 055 - 2. Keeping them clean and dry, prevent kinking, and being careful when unfolding rules to prevent breakage.
- 055 - 3. Install heating fixtures which must be in a true alignment.
- 055 - 4. Breakage of the glass tubes renders the level inoperative.
- 056 - 1. Keep the soldering points clean.
- 056 - 2. The type of job to be done and the size of the soldering iron needed.
- 057 - 1. The user of the tools.
- 057 - 2. Cleaning, repairing, sharpening, lubricating, and oiling.
- 057 - 3. When tools are being stored for long periods of time, they should be placed above the floor. Such storage will allow air to circulate around the toolbox and will keep the moisture content down, thereby preventing rust.
- 057 - 4. All fingerprints, dirt, etc., should be wiped from the metal surfaces of tools to prevent rust.
- 058 - 1. Shop equipment is large tools that are used frequently but are too bulky and cumbersome to transport from one job to another in a toolbox.
- 058 - 2. A die set consists of a stock or handle, a holder or frame, and a set of dies for different sizes of pipe.
- 058 - 3. A bench grinder is used for sharpening tools, removing excess metal from work, and smoothing metal surfaces.
- 058 - 4. Pipe die sets range from small 1/8" inch to 12 inches.
- 058 - 5. A tube bender is designed to shape and form smooth bends in soft copper tubing and pipe without collapsing the pipe.
- 058 - 6. Never use the jaws of a vise as an anvil and never use a pipe to increase the handle leverage.



STOP -

1. MATCH ANSWER SHEET TO THIS EXERCISE NUMBER.
2. USE NUMBER 1 OR NUMBER 2 PENCIL.

54730 01 25

EXTENSION COURSE INSTITUTE
VOLUME REVIEW EXERCISE
RELATED SUBJECTS

Carefully read the following:

DO'S:

1. Check the "course," "volume," and "form" numbers from the answer sheet address tab against the "VRE answer sheet identification number" in the righthand column of the shipping list. If numbers do not match, take action to return the answer sheet and the shipping list to ECI immediately with a note of explanation.
2. Note that numerical sequence on answer sheet alternates across from column to column.
3. Use a medium sharp #1 or #2 black lead pencil for marking answer sheet.
4. Circle the correct answer in this test booklet. After you are sure of your answers, transfer them to the answer sheet. If you *have* to change an answer on the answer sheet, be sure that the erasure is complete. Use a clean eraser. But try to avoid any erasure on the answer sheet if at all possible.
5. Take action to return entire answer sheet to ECI.
6. Keep Volume Review Exercise booklet for review and reference.
7. If *mandatorily* enrolled student, process questions or comments through your unit trainer or OJT supervisor.
If *voluntarily* enrolled student, send questions or comments to ECI on ECI Form 17.

DON'TS:

1. Don't use answer sheets other than one furnished specifically for each review exercise.
2. Don't mark on the answer sheet except to fill in marking blocks. Double marks or excessive markings which overflow marking blocks will register as errors.
3. Don't fold, spindle, staple, tape, or mutilate the answer sheet.
4. Don't use ink or any marking other than a #1 or #2 black lead pencil.

NOTE: NUMBERED LEARNING OBJECTIVE REFERENCES ARE USED ON THE VOLUME REVIEW EXERCISE. In parenthesis after each item number on the VRE is the *Learning Objective Number* where the answer to that item can be located. When answering the items on the VRE, refer to the *Learning Objectives* indicated by these *Numbers*. The VRE results will be sent to you on a postcard which will list the *actual VRE items you missed*. Go to the VRE booklet and locate the *Learning Objective Numbers* for the items missed. Go to the text and carefully review the areas covered by these references. Review the entire VRE again before you take the closed-book Course Examination.

MODIFICATIONS

Pages 2-4 of this publication has (have) been deleted in adapting this material for inclusion in the "Trial Implementation of a Model System to Provide Military Curriculum Materials for Use in Vocational and Technical Education." Deleted material involves extensive use of military forms, procedures, systems, etc. and was not considered appropriate for use in vocational and technical education.

5A

37. (024) The wearing of loose clothing around moving belts, chains, or flywheels is a safety violation classed as
- a. horseplay.
 - b. poor housekeeping.
 - c. improper working methods.
 - d. poor housekeeping and horseplay.
38. (025) The main objective of the ground safety section is to
- a. reduce accidents.
 - b. establish safety policies.
 - c. establish safety procedures.
 - d. reduce vehicle accidents.
39. (026) Which of the following manuals would you check for information on shop safety?
- a. AFM 85-1.
 - b. AFM 85-12.
 - c. AFM 85-19.
 - d. AFM 127-101.
40. (026) Which of the following publications is written especially for people who work around electricity?
- a. AFP 85-1.
 - b. AFM 85-12.
 - c. AFM 85-14.
 - d. AFM 127-101.

41. (027) If air is being sucked in and blown out of the chest cavity through a wound, you should
- a. stop the bleeding.
 - b. make the wound airtight as soon as possible.
 - c. keep the patient warm.
 - d. treat the patient for shock.
42. (027) Which of the following are most likely to cause shock?
- a. Burns.
 - b. Head wounds.
 - c. Belly wounds.
 - d. Chest wounds.
43. (027) After freeing a victim from a live wire, the first thing you should do is to
- a. treat the victim for shock.
 - b. start artificial respiration.
 - c. keep the victim warm.
 - d. go for help.
44. (028) When you are giving mouth-to-mouth respiration, your rate of breathing should be how many times per minute?
- a. 5 to 10.
 - b. 12 to 20.
 - c. 20 to 25.
 - d. 25 to 30.
45. (029) Disability classifications include all of the following except
- a. fatal injury.
 - b. permanent total disability.
 - c. temporary partial disability.
 - d. permanent partial disability.
46. (030) The responsibility for reporting unsafe acts or conditions belongs to
- a. NCOICs.
 - b. commanders.
 - c. base commanders.
 - d. every member of the Air Force.

MODIFICATIONS

Pages 7-8 of this publication has (have) been deleted in adapting this material for inclusion in the "Trial Implementation of a Model System to Provide Military Curriculum Materials for Use in Vocational and Technical Education." Deleted material involves extensive use of military forms, procedures, systems, etc. and was not considered appropriate for use in vocational and technical education.

61

12. (044) Blueprints are copied by
- a. tracings.
 - b. tracings and drawings.
 - c. drawings and pictures.
 - d. mechanical drawings.
72. (044) The negative for the blueprint is known as a
- a. tracing.
 - b. print.
 - c. drawing.
 - d. mechanical drawing.
73. (045) The simplest and most generally used copying process for making prints is the
- a. Vandyke.
 - b. blueprint.
 - c. Ozalid print.
 - d. photostat print.
74. (046) On a drawing, the heaviest lines are used for the
- a. border.
 - b. object.
 - c. centerlines.
 - d. dimension lines.
75. (046) Which lines on a drawing outline the specific item illustrated by the draftsman?
- a. Border.
 - b. Object.
 - c. Center.
 - d. Dimension.
76. (047) An architect's scale is used for
- a. drawings.
 - b. map drawing.
 - c. plotting.
 - d. scaling blueprints for machine and structural work.
77. (048) A blueprint is usually made up of how many different views?
- a. 5.
 - b. 4.
 - c. 3.
 - d. 2.
78. (049) An 18-inch pipe wrench will handle pipe up to how many inches in diameter?
- a. 2.
 - b. 2 1/2.
 - c. 3.
 - d. 3 1/2.
79. (049) Which of the following wrenches is often called a knuckle buster?
- a. Pipe wrench.
 - b. Adjustable end wrench.
 - c. Open end wrench.
 - d. Box end wrench.
80. (050) When you are grinding a tip on a screwdriver, too much heat will
- a. harden the tip.
 - b. leave the tip rough.
 - c. soften the tip.
 - d. do no harm.
81. (051) The three tool items needed to prepare copper tubing for installation are
- a. screwdriver, bender, and snapper.
 - b. tubing cutter, bending spring, and flaring tool.
 - c. water pump pliers, flaring tool, and adjustable wrench.
 - d. bending spring, pipe wrench, and flaring tool.
82. (052) What file is sometimes referred to as a rattle file?
- a. Round file.
 - b. Half-round file.
 - c. Mill file.
 - d. Hand file.



- 83. (052) A good method of preventing pinning is to
 - a. always use a new file.
 - b. use oil on the metal.
 - c. rub chalk on the file.
 - d. use more pressure on the backward stroke.

- 84. (053) The cutting angle of a cold chisel is determined by the
 - a. type of chisel used.
 - b. shape of the metal being cut.
 - c. size of chisel used.
 - d. softness or hardness of the metal being cut.

- 85. (053) What type of hammer should you use with a punch or chisel?
 - a. Sledge.
 - b. Claw.
 - c. Ball-peen.
 - d. Mallet.

- 86. (054) How many teeth per inch should a hacksaw blade have for cutting copper tubing?
 - a. 12.
 - b. 14.
 - c. 18.
 - d. 24.

- 87. (055) What rule is most generally used by the heating equipment mechanics?
 - a. Yardstick.
 - b. 6-foot folding rule.
 - c. 12-foot flexible rule.
 - d. 36-foot flexible tape.

- 88. (056) All soldering irons or guns are rated in
 - a. watts.
 - b. amp.
 - c. volts.
 - d. millivolts.

- 89. (057) Before storing tools that have been washed with water, you should
 - a. dry them in the sun.
 - b. coat them with linseed oil.
 - c. dry them in a bake oven.
 - d. coat them with a light grade of engine oil.

- 90. (058) When the cutting wheel on a pipe cutter becomes dull, you should
 - a. replace it.
 - b. sharpen it with a file.
 - c. sharpen it on a grinder.
 - d. sharpen it on an oil stone.

63

54730 02 7410

CDC 54730

APPRENTICE HEATING SYSTEMS SPECIALIST

(AFSCs 54730 and 54730A)

Volume 2

Fundamentals



11-1

Extension Course Institute

Air University

70

65

Preface

THIS VOLUME is written for personnel in the Air Force whose duties require them to have a knowledge of the fundamentals of heating.

The training, of which this second volume is a part, is intended for candidates who desire to progress to the 3 level, Apprentice Heating Systems Specialist, AFSC 54730.

The discussions in the five chapters of this volume are directed toward the fundamentals of heating; electrical principles; electrical, electronic and pneumatic controls; the fundamentals of pipe and copper tubing; the principles of heating; and fuels and fuel systems.

In the first and second chapters, there are learning objectives covering the principles of electricity, the types and operation of electric, electronic and pneumatic controls. The third chapter covers pipe characteristics and information about copper tubing. The fourth chapter's objectives handle the theory of heat, heat transfer, combustion and fundamentals of air pollution. The fifth chapter covers solid, liquid and gaseous fuels.

If you have any questions on the accuracy or currency of the subject matter of this text, or recommendations for its improvement, send them to Tech Tng Cen/TTOC, Sheppard AFB TX 76311.

If you have questions on course enrollment or administration, or on any of ECI's instructional aids (Your Key to Career Development, Behavioral Objective Exercises, Review Exercise, and Course Examination), consult your education officer, training officer, or NCO, as appropriate. If he can't answer your questions, send them to ECI, Gunter AFS AL 36118, preferably on ECI Form 17, Student Request for Assistance.

This volume is valued at 39 hours (13 points).

Material in this volume is technically accurate, adequate, and current as of June 1974.

66

Contents

	<i>Page</i>
<i>Preface</i>	iii
<i>Chapter</i>	
1 Basic Electricity	1
2 Electrical Controls	22
3 Pipe and Copper Tubing	65
4 Principles of Heating	83
5 Fuels and Fuel Systems	106
<i>Answers for Exercises</i>	135

72



NOTE: In this volume, the subject matter is developed by a series of Learning Objectives. Each of these carries a 3-digit number and is in boldface type. Each sets a learning goal for you. The text that follows the objective gives you the information you need to reach that goal. The exercises following the information give you a check on your achievement. When you complete them, see if your answers match those in the back of this volume. If your response to an exercise is incorrect, review the objective and its text.

Basic Electricity

YEARS AGO, MAN learned how to put electricity to work. But the early inventors could not possibly foresee the almost limitless applications of electricity to labor-saving, comfort-giving, and safety devices. Even as late as immediately prior to World War II, most of the developments in the heating field were centered on hand-fired furnaces and boilers. With the later developments of modern electric and electronic controls and instruments, however, it became necessary that the heating specialist also become familiar with these controls and with the electricity that operates them.

You can realize the effect that electricity has had when you see a burner or stoker motor start and operate. However, the forces at work and the action taking place in the wire conductors are not easy to visualize. Since it is impossible for the human eye to actually see the flow of electrical current through a conductor, it becomes necessary for you to be sufficiently acquainted with the nature and behavior of electricity to visualize the action. Your ability to form accurate mental pictures of the events occurring within electrical circuits does not depend on a high degree of intelligence. Instead, this seemingly difficult ability hinges primarily on your understanding a small number of electrical principles which, surprisingly enough, are logical and not difficult to understand. Once you do understand the principles, you can build on them to learn and understand the rules that govern the practical applications of electricity in all of its existing relationships. When equipped with this basic knowledge, you will be in the best possible position to mentally "see" what takes place inside the electrical circuit.

This chapter deals with electricity in its many aspects and with heating controls which not only operate by electricity, but electronically and pneumatically.

1-1. Theory of Electrical Current

All activity which takes place in any type of electrical circuit depends on the behavior of tiny electrical charges called electrons. To understand the behavior of electrons, you must first understand the nature of matter. Hence, your first step in the study of electricity involves your learning how electrons fit into the world of physical things that surround us.

200. Give a description of matter, differentiate between compounds and mixtures, and specify what makes electric current.

Have you ever considered that everything around you, even the air you breathe, occupies space and has weight? Anything that meets this description is called matter. With this definition, you would be hard pressed, in fact it is impossible, to name a physical substance or object that is not matter. Coal, water, wood, gas—all are examples of matter.

Just what makes up matter? Well, it is made up of very small units called molecules. The molecules are made up of atoms. The atoms, in turn, are made up of minute particles called protons, neutrons, and electrons.

Elements. Not only does matter consist of the minute particles mentioned in the preceding paragraph, but it can also be stated that all matter is composed of elements.

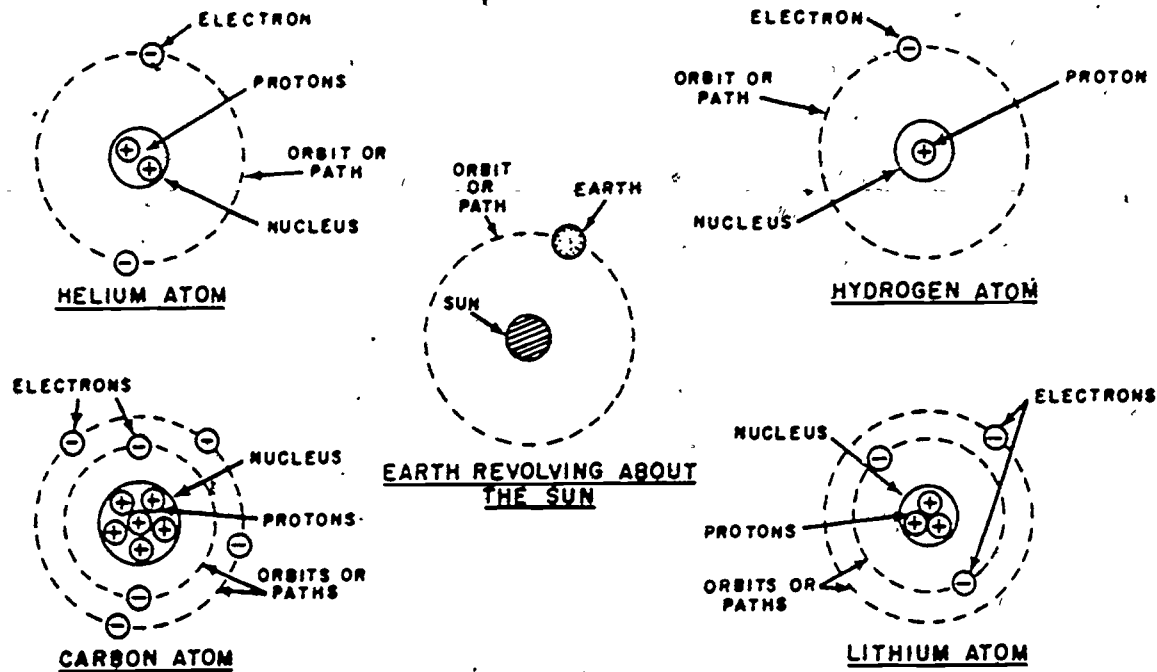


Figure 1-1. Structure of common atoms.

Elements are the so-called "building blocks of nature." They cannot be divided or reduced to a simpler substance by chemical means. Examples of elements are pure iron, gold, silver, copper, hydrogen, and oxygen. There are some 100 plus natural elements known to man. All of the familiar substances in our universe are composed either of these elements or of combinations of them. There are about a dozen other elements that have been synthetically prepared (manmade) in laboratories.

Elements may be combined in two different ways, either in compounds or mixtures. A compound is a combination of elements that can be separated only by chemical means. Examples of familiar compounds are pure water (which is composed of the elements hydrogen and oxygen) and salt (which is composed of the elements sodium and chlorine). A mixture, on the other hand, is a combination of elements or compounds that can be separated by physical means. Examples of mixtures are brass (a mixture of copper and zinc) and air (a mixture of nitrogen, oxygen, carbon dioxide, and several other gaseous substances).

Molecules. We find that a drop of water can be divided into many small parts. In fact, it can be divided until the parts are no longer visible, yet each part still retains the characteristics of the original drop. The smallest part of a substance that has all the

characteristics of that substance is called a molecule. A single drop of water is made up of many millions of molecules, as are all other substances.

A molecule of water is expressed chemically as H_2O , meaning that each molecule is composed of two distinct elements. H_2O stands for the combination of two parts of the element hydrogen (H_2) and one part of the element oxygen (O). The water molecule has a very simple structure, consisting of only two common elements. Molecules of other substances may be more complex, sometimes consisting of several elements. Just what makes up molecules? Perhaps, more specifically, we should ask what elements make up molecules.

Atoms. The individual elements that combine to form molecules are made up of atoms. For a long time it was thought that the atom was the smallest subdivision of matter. However, in recent years the electron theory has been advanced; it helps to explain many electrical and chemical phenomena. According to the electron theory, atoms are composed of minute units called protons, neutrons, and electrons. Furthermore, all the atoms that make up a particular element are identical in their structure. The reason for the different types of elements then—why iron differs from oxygen, for example—is that the protons, neutrons, and electrons differ in

number and are arranged differently within the atoms of each element.

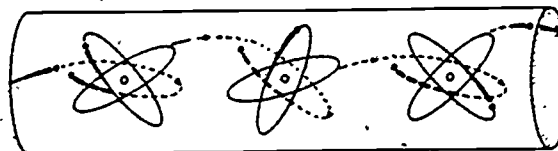
Each proton and each electron carries an electrical charge—protons carry a positive charge, whereas electrons carry a negative charge. The neutrons carry no charge. The electron theory explains that all atoms are similarly constructed of a central nucleus and orbiting electrons. The protons and neutrons are contained in a closely packed nucleus in the center of the atom. The electrons spin around the nucleus in much the same manner as the planets move around the sun.

You may recall from your high school science that our solar system has nine planets that revolve around the sun. In the same manner, one atom may have nine electrons spinning around its nucleus; other atoms may have more or fewer electrons.

Figure 1-1 shows you the atomic structure of four common atoms. Notice that the structure of each is similar and can be compared with our planet earth and its relationship with the sun. The hydrogen atom, as shown in the figure, is the simplest of all atoms. It contains one electron revolving around one proton, which acts as a nucleus. Because the negative charge of the electron is equal to the positive charge of the proton, the atom is electrically balanced or neutral. For simplification, only the charged units (proton and electron) of the atom are shown in the illustration. However, as we previously discussed, the nucleus of all atoms contains neutrons as well as protons. A proton is said to weigh many times (about 1840 times) more than an electron.

Take a look at the helium atom in figure 1-1. You notice that the nucleus contains two protons. The positive charges of these two protons are balanced by the negative charges of the two revolving electrons, and the electrical charge of the entire atom is neutral. Atoms of other elements are more complex than the hydrogen and helium atoms. For example, look at the lithium atom shown in figure 1-1. Notice that there are three electrons revolving around the nucleus in two different paths or orbits. An even more complex atom, the carbon atom, is also shown in the figure. It has six electrons revolving around the nucleus in two different paths.

The four common atoms shown in figure 1-1 illustrate the electron theory that the only difference in atoms of the various elements is in the number and arrangement of the protons, neutrons, and electrons. In some elements, the electrons in the outer paths are



ENLARGED SECTION OF COPPER WIRE

Figure 1-2. Electron movement in a conductor.

called free electrons, because they can be dislodged from their regular path and be made to move from one atom to another. It is the movement or displacement of these free electrons that gives us electrical energy.

Electron Flow. Our discussion of protons and electrons is important. Electrons moving or flowing through a conductor (wire) are called an electric current. The electric current always flows from a point of negative potential (excess of electrons) to a point of positive potential (deficiency of electrons).

Current flowing through a conductor may be compared to water flowing through a pipe. If we have a pipe full of water and pump in more water at one end, water is forced out of the other end. If a copper wire containing billions of free electrons in the outer paths of the copper atoms has electrons forced into one end of the wire, electrons are forced out of the other end. The excess of electrons at one end forces an electron away from a nearby atom and causes it to crowd an electron away from the next atom, and so on. This electron flow principle is illustrated in figure 1-2. Imagine an almost instantaneous shift of billions upon billions of free electrons throughout the entire length of the conductor, and it is not difficult to picture the electric current. Science tells us that current (electron flow) flows through a conductor at the speed of light (186,000 miles per second).

Exercises (200):

1. What are known as the "building blocks of nature"?
2. Describe matter.
3. What is current flowing through a conductor compared with?

4. Water is expressed chemically as H_2O .
Water is composed of what elements?

5. Explain the difference between compounds and mixtures.

6. What is the smallest part of a substance that has all the characteristics of that substance called?

7. What are the elements called that form molecules?

8. Electric current is composed of what?

201. Define voltage, and indicate the effects of current and the unit of measurement for resistance.

There are three fundamental factors which must be present before you can have an operating electric circuit—voltage, current, and resistance. If you understand the relationships among these three units, then you have a good foundation toward understanding and increasing your knowledge of electricity. This objective is devoted to a discussion of electrical units.

Voltage. Just as you need a pump of some sort to keep water flowing through a pipe, an electrical pressure is also needed to make current flow through a conductor. The "pump" that produces this pressure may be a battery or an electric generator which can produce a potential difference in the conductor. Water pressure is measured in pounds per square inch; electrical pressure is measured in volts. One volt is the electrical pressure required to force 1 ampere of current through a resistance of 1 ohm. Electrical pressure, electromotive force (emf), and potential difference are used interchangeably; they all mean the same thing—voltage. The basic unit of measurement for voltage is the volt.

The voltage of an ordinary dry cell battery, such as a flashlight battery, is $1\frac{1}{2}$ volts. The

70

voltage for most domestic electric service is about 120 volts. When voltage is applied to a circuit, a certain amount of current will flow through the circuit. If the voltage is increased, then the current flow will increase in direct proportion to the voltage.

Current. You have already learned that current flow is simply the movement of electrons through a conductor. Electric current and some of its effects were discovered long before the electron. The fact that current flow through a circuit was in a given direction was also known. It was this fact that gave rise to the concept of polarity.

To provide a standard method of indicating the direction of current flow, one terminal of the early chemical cell used as a source of electrical energy was marked positive (plus); the other terminal was labeled negative (minus). It was then assumed that when a circuit was connected to the cell terminals, a current would flow through the circuit from the positive terminal to the negative terminal (plus to negative). This theory (conventional current flow), however, soon gave way with the discovery of the electron. We now know that when a circuit is connected to the terminals of a battery, current flows through the circuit from the negative terminal to the positive terminal (electron flow theory).

Current has four effects—heat, magnetism, chemical action, and physical shock. Current always produces heat when it flows through a conductor. The amount of heat produced depends on the material of the conductor and on the amount of current flowing. For example, electric irons and toasters must have heating elements that produce enough heat to be practical. The light produced by an electric lamp is caused by current flowing through a threadlike conductor inside the lamp, called a filament. The filament must be heated so that it glows. However, the conductor that carries the current to the filament must not become hot enough to glow.

Magnetism is produced when current flows in a conductor. This is a very important effect, for it is the basis for millions of electrical machines, such as generators, motors, and electromagnets. Without this effect, there is no known way to generate electricity cheaply and convert it into mechanical energy to perform work.

Current produces chemical action when it flows through a liquid. Examples of this effect are the charging of a storage battery and the electroplating process. Physical shock is the unpleasant and sometimes dangerous sensation caused by coming into contact with

71

a source of electric energy. We often speak of voltage as the cause of shock; however, the fact is that current flowing through the human body produces the physical shock. The pain and the muscular contraction are due to the effect of current on the nerve centers and on the nerves themselves.

Current is measured in terms of the number of coulombs that pass by a given point in one second. When a conductor is connected across a source of voltage, and 6.28×10^{18} electrons (one coulomb) pass through the conductor in a period of 1 second, then one unit of current flow has occurred. This unit of current flow is called an ampere.

Resistance. The definition of resistance is to oppose or retard. In electrical terms, resistance means the opposition to the movement of free electrons through a circuit or conductor. The amount of opposition offered by a conductor depends on the material of the conductor, its length, its cross-sectional area, and its temperature.

Resistance to electric current is present in all matter, but one material may have much more resistance than another. Air, rubber, glass, and porcelain have so much resistance that they are called insulators and are used to confine electricity to its proper circuit. The rubber covering on the wires to an electric lamp prevent the wires from touching each other and causing a short circuit. The rubber also protects a person who is using the lamp from receiving an electric shock. Air acts as an insulator whenever a light switch is opened. Air fills the gap between the open contacts of the switch, and no current flows because of the high resistance. However, even air may act as a conductor if the voltage is high enough; otherwise, there could not be the discharge which appears in a lightning stroke.

Metals are good conductors of electricity, but some are better than others. Copper and silver are both good conductors of electricity because of their relatively low resistance. Aluminum is not as good but is used for long overhead spans because of its light weight. Steel is a poor conductor, although it is used in combination with aluminum for added strength. Alloys of nickel and chromium are used in neater elements to provide a specific resistance which passes enough current to heat the elements to a red glow. The alloy makes it possible to operate the elements at high temperatures without melting. Since copper is a good conductor and also relatively inexpensive, it is widely used in electrical circuits. However, copper is seldom used in its pure form. It is usually mixed with other metals to form a copper alloy.

The resistance of a copper wire is determined by three things—the cross-sectional area, the length, and the temperature. In normal temperature ranges, the change in resistance is very small. The main factors of resistance are the cross-sectional area of the wire and its length. Since a wire with a large diameter has a greater cross-sectional area than a smaller wire, it therefore has less resistance. A long wire has more resistance than a short one. A cold wire has less resistance than a hot wire. The ohm is the standard unit of measurement for resistance.

Exercises (201):

1. What is voltage?
2. What effects does current have?
3. What is produced when current passes through a conductor?
4. Silver and copper are considered good conductors because of their low resistance. How is the resistance of copper determined?
5. What is the standard unit of measurement for resistance?

202. Describe direct and alternating current.

Electricity in motion is called dynamic electricity. You previously learned that current flow is simply the movement of electrons through a conductor. Therefore, any time electrons flow through a conductor, dynamic electricity is at work. If the electrons move in one direction through the conductor, we have direct current (dc). If they move back and forth through the conductor at a specific interval, we have alternating current (ac).

In order to have current flow in a circuit, we must have a source of electrical energy. There are a number of sources of electricity;

however, you are concerned only with the most common and the most practical sources. In this section, we discuss the two types of electric current.

Direct Current. Thus far in our discussion, electric current has been understood as a steady flow of electrons, caused by a voltage applied to a circuit. Furthermore, we said that current flows from a negative potential to a positive potential, or that there is a steady flow in one direction only. This type of current is known as direct current. There are many uses for which only direct current is suitable, such as battery charging, electroplating, and certain electronic circuits.

Certain electrical circuits make use of a particular type of direct current, called pulsating direct current. A pulsating direct current is obtained by using specially designed switches which alternately turn a direct current off and on, causing the current to flow in pulses. The automobile ignition coil circuit is a good example of pulsating direct current. Each time the ignition points close, a short pulse of direct current flows through the ignition coil. The current pulses always flow in the same direction.

Alternating Current. A current which flows first in one direction and then reverse and flows in the opposite direction is an alternating current. One direction is called positive (+) and the other is called negative (-).

Alternating current cannot be obtained from batteries. It originates from a mechanical device called a generator or alternator. Starting with zero voltage, the ac generator builds up a voltage which pushes in the positive direction. This positive voltage increases until a maximum is reached, after which it decreases again to zero value. The voltage then builds up to a maximum value in the negative (opposite) direction and finally decreases to zero. The period of time required to go from zero to positive maximum and back to zero, to negative maximum and again to zero, is called a cycle. The number of cycles occurring per second is the frequency.

Exercises (202):

1. Describe direct current.
2. Describe alternating current.

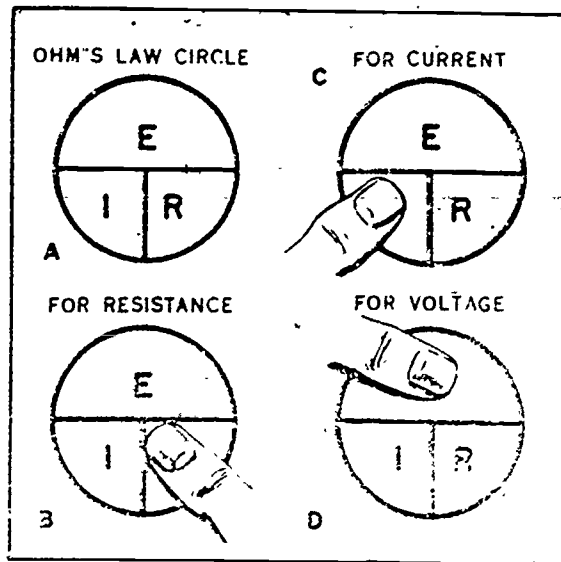


Figure 1-3. Ohm's law.

203. Using Ohm's law, solve a problem with given values.

There is a definite relationship between the voltage, current, and resistance of any circuit or part of a circuit. If the voltage is increased, the current increases proportionately; and if the resistance is increased, the current decreases proportionately. In this section we discuss the basic law on which this relation is based. We use the law to compute quantities of voltage, current, and resistance in the three basic electrical circuits.

A German scientist, Ohm, developed a law for the quantities of a circuit as follows: One volt is the pressure required to force 1 ampere of current through a resistance of 1 ohm. This law can be reduced to a simple formula where E stands for volts, I stands for current, and R stands for resistance, as shown by the Ohm's law circle in figure 1-3. The formula is solved by simple division or multiplication. Where two of the quantities are known, the third can always be determined. If you block out the unknown in the formula, the remaining portion tells how to solve the problem.

Suppose you know the voltage and current for a circuit and want to know what the resistance is for the circuit. Place your finger over the R, and the remaining part is E over I.

This can be written as $R = \frac{E}{I}$. The problem is solved by dividing I into E. Given a pressure of 120 volts and a current of 5 amps, what is the resistance? Five goes into 120 twenty-four

times, so the answer is 24 ohms of resistance.

If you know the resistance of a piece of equipment and the voltage applied to it, how much current will the equipment draw? Cover the I and you get volts divided by the resistance. You have a 4-ohm resistor and want to connect it to a 120-volt source. How much current will the resistor draw? Divide 120 by 4 and you get 30 amperes. Why is it important for you to know this? Branch circuits in buildings and barracks are protected by fuses or circuit breakers. If a 30-ampere load is plugged into a branch circuit which is protected by a 20-ampere fuse, the fuse will blow and the equipment will not work.

To find the voltage in a circuit, cover the E and the solution is I times R . It is sometimes important to know what the voltage across a piece of equipment should be, so that you can tell if it is working properly. When you know the resistance and measure the current with an ammeter, then you can calculate the voltage drop. If you have a resistance of 8 ohms and measure 10 amperes in the circuit, what is the voltage? Using the formula $I \times R$ (10 times 8) gives you 80 volts, which is the voltage across the resistor.

Exercises (203):

1. What equation is used to determine the voltage across a component of a circuit if you know the unit's resistance and the current flow?

2. What law is commonly used to compute voltage, current, and resistance in an electrical circuit?

3. What is Ohm's law?

4. Using Ohm's law given in text, compute the current flow through a 120-volt circuit that has a 6-ohm resistor.

204. Given a hypothetical situation, determine the type of circuit involved.

Series Circuit. A series circuit is defined as one in which the current has only one path to follow. Knowing that electricity flows through copper conductors and that there is a pressure (voltage) pushing it through these conductors, the electricity will seek to find new paths through which it can travel. Figure 1-4 shows a series circuit. The series circuit derived its name from the fact that the electricity flows through a series of lamps that are connected one following the other, with each lamp consuming an equal amount of current.

In a series circuit, as shown in figure 1-4, when any one of the lights in the circuit fails to burn, all other lights in the circuit will also fail to light because the circuit is broken.

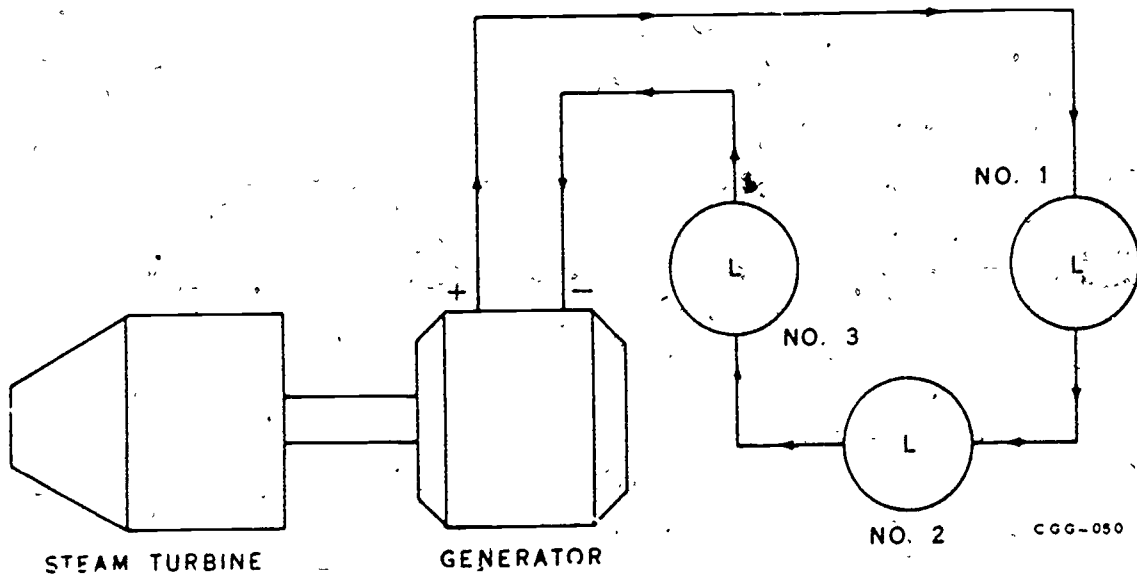


Figure 1-4. Series circuit.

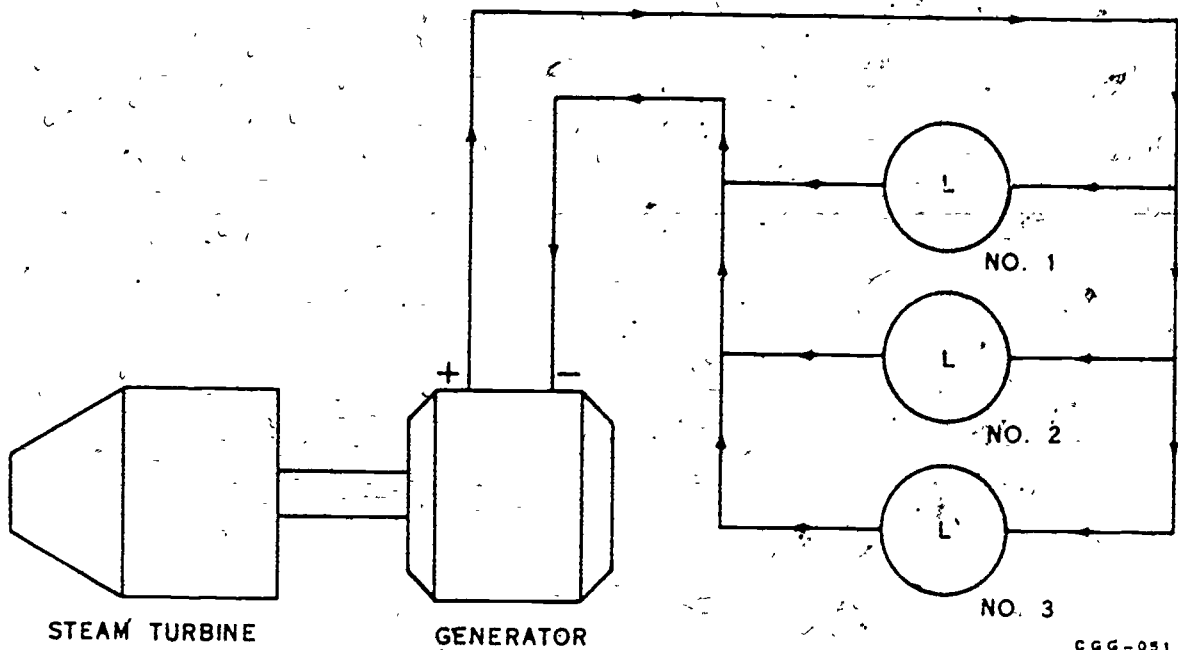


Figure 1-5. Parallel circuit.

Series-connected circuits are used where electrical heating system controls are used. All safety devices and controls must be hooked in series.

(S) Parallel Circuit. A parallel circuit can be defined as one in which there is more than one path for the current to flow. In a parallel circuit, two or more electrical devices provide independent paths through which the current can flow. The voltage across each device in parallel is the same. The total current in the circuit is equal to the sum of the currents flowing through all devices. Thus, the total amount of current is greater than the current in any individual part, and the total resistance (the resistance of the circuit as a whole) is less than the smallest resistance in it. (By Ohm's law—the current is greater; therefore, the resistance must be less.) The more electrical devices or resistors connected in parallel, the greater will be the total current; hence, the smaller is the resistance of the complete circuit.

Electrical devices are connected in parallel to decrease the total resistance and to allow them to be operated independently. If one device in a parallel circuit burns out, the others can still be operated. (One path is broken, but the others are still complete.) Figure 1-5 shows a parallel circuit.

Series-Parallel Circuit. The series-parallel circuit is a combination of the above two circuits and is not used as extensively as the other two.

Exercises (204):

1. What are the three basic circuits?
2. Describe a series circuit.
3. What is the purpose of a parallel circuit?
4. When would you, as a heating specialist, be required to use only a series circuit?
5. Your Christmas tree lights suddenly go out. After checking the bulbs you find one that is bad. What type circuit are your lights wired in?

BASIC SYMBOLS

75

	Battery		Voltmeter
	Coil or Winding		Ammeter
	Electromagnet		Wattmeter
	Resistor		Generator
	Rheostat		Motor
	Lamp		Commutator or Armature
	Switch, Single Pole, Single Throw		Conductors Joined
	Fuse		Conductors not Joined
	Switch, 2-Pole Single Throw		Transformer, General
	Switch, Single Pole, Double Throw		Transformer, Iron Core
	Switch, 2-Pole, Double Throw		Capacitor
	Circuit Breaker		Actuating Device, Thermal
	Contact, Normally Open		Ground Connection
	Contact, Normally Closed	E	Voltage
		I	Current
		R	Resistance
		Ω	Ohm
			Cycle
		+	Positive
		-	Negative

Figure 1-6. Electric symbols.

205. Cite purpose and types of symbols and wiring diagrams and match the symbol with the correct circuit component.

Electrical symbols are used in electrical plans, wiring diagrams, and schematics. You often use symbols to install electrical circuits and locate malfunctions. Therefore we will cover both symbols and wiring diagrams in this objective.

Symbols. Figure 1-6 shows you the most common electrical symbols that you use in your work. Study them and become familiar with them and with others that you may find in technical orders and manufacturer's manuals.

Usually when a job is assigned to you, a work order, a list of material, and a drawing accompany the assignment. There may be a time when your supervisor gives you only a drawing and tells you to prepare a list of material required for the job. You might receive a rush work order to install service conductors to a new building, but no material list or blueprint. In this case, you would have to go through the building and estimate the kilowatt (kw.) load for the building according to the number of lights and outlets, and their voltage, to determine the proper size service conductors. If you had the electrical drawing of the building, you could figure the kw. load of the lights and each piece of required equipment. The lights and equipment would,

of course, be represented by symbols on the drawing. By using the drawing, you would be able to get a more accurate kw. load estimate.

The above example illustrates how essential your knowledge of the symbols in figure 1-6 is. Do not be alarmed by the number of symbols. Experience and learning a few simple rules make recognition easy. Outlets are designated by a circle with a letter or added line to show their purpose. Wall outlets are distinguished from ceiling outlets by a short line outside the circle. Special-purpose outlets are identified by a subscript added to the symbol.

Switches are simply designated by the letter S. The subscript following in small print shows their special purpose. Panels, or control panels, disconnects, and service switches are indicated by a rectangular shaped symbol. In practically every case where a letter is used with a symbol, it is the first letter of the descriptive name. Symbols are used because it is easier to use a symbol than a picture of the unit. It also takes less room and is faster.

Wiring Diagrams. Wiring diagrams are the "roadmaps" for electrical circuits. They are detailed drawings that show how the wires of a circuit connect the electrical fixtures and other components together. Unlike the single-line drawings in electrical plans, wiring diagrams show the individual wires and how each is connected to the circuit components.

You will find that there are variations in wiring diagrams. Sometimes they are drawn to show the actual picture of the circuit components. Sometimes symbols are used to represent circuit components. In either case,

wiring diagrams show each circuit component in relation to the other components. Wiring diagrams are an important, if not essential, tool in your job of troubleshooting and replacing defective circuit components.

In figure 1-7 you see a wiring diagram. The diagram shown is lighting circuit B-19 depicted in the electrical plan in figure 1-8. In this wiring diagram you see that the circuit components are shown as pictures instead of being represented by symbols. The diagram shows how each component is connected to the circuit in relation to the other components. When circuits are drawn in picture form, as in the case of figure 1-7, the drawing is referred to as a pictorial wiring diagram.

Schematic wiring diagrams, on the other hand, use symbols to represent circuit components. However, like wiring diagrams, they always show each circuit component in relation to the other components. As in the schematic diagram, the circuit components are always represented by symbols. They give you an overall symbolic view of a circuit and show at a glance how that circuit functions. Therefore, schematics are very useful when you study circuit operation and troubleshoot circuit troubles.

Figure 1-8 shows a schematic wiring diagram. As you recall, the schematic is a separate set of drawings that shows the separate of the circuit components as shown in figure 1-7. In a schematic, the circuit components are represented by symbols. On a schematic, a wiring diagram and a schematic diagram are used for troubleshooting. You will see the effect of

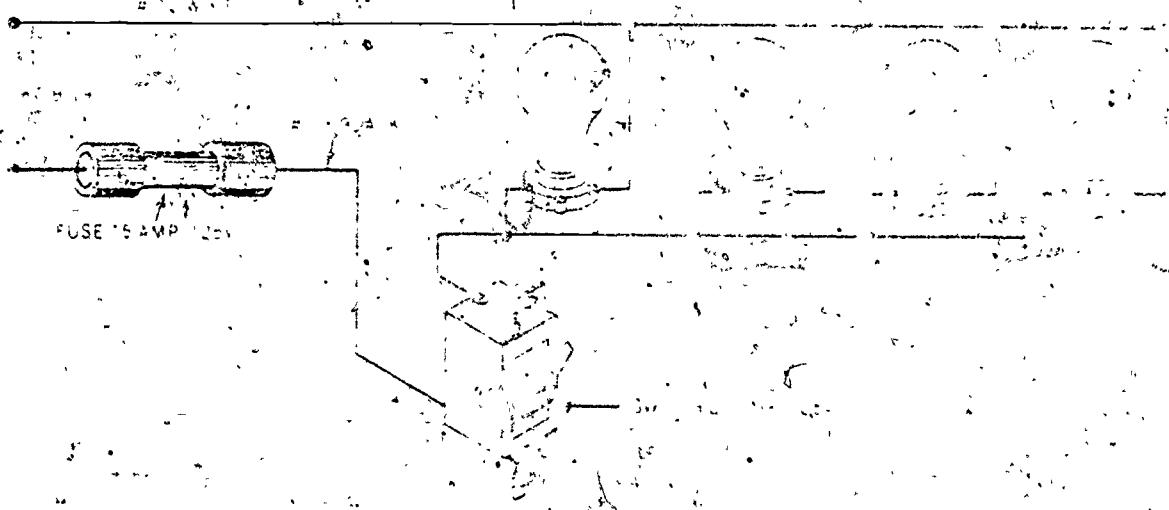
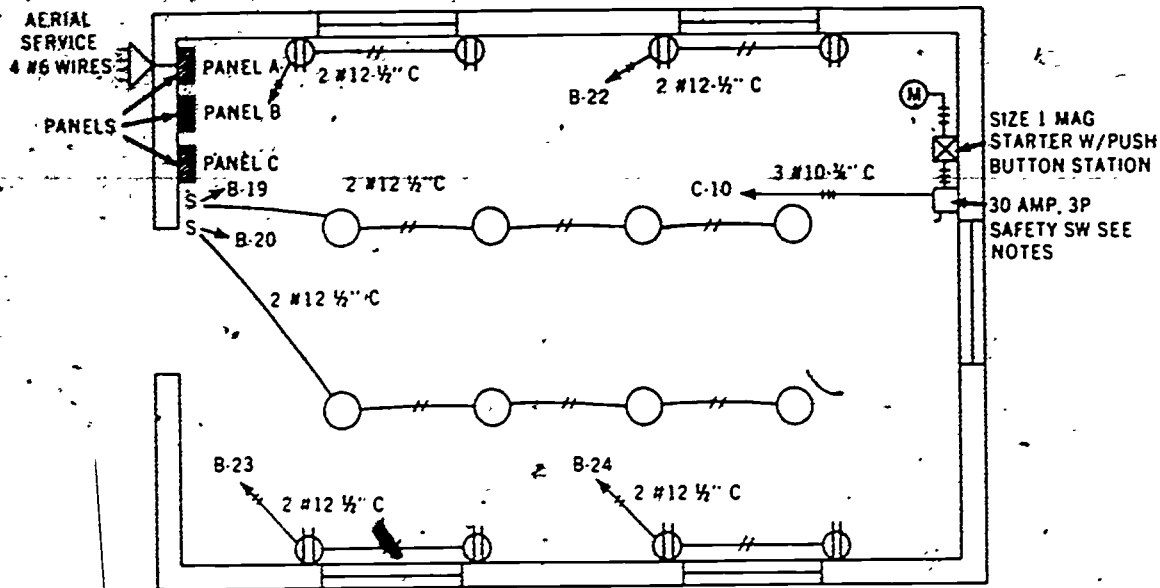


Figure 1-7. Wiring diagram.



LEGEND		GENERAL NOTES		UNITED STATES AIR FORCE AIR TRAINING COMMAND SHEPPARD AIR FORCE BASE WICHITA FALLS, TEXAS OFFICE OF THE BASE CHIEF ENGINEER			
	POWER PANEL	1. INSTALL MOTOR CONTROLS 4'-0" ABOVE FLOOR AND 4'-0" FROM NORTH WALL 2. INSTALL DUPLEX OUTLETS 1' ABOVE FLOOR 3. ALL LIGHTING FIXTURES SHALL BE ACME TYPE 117 OR EQUAL 4. ALL WIRING SHALL BE CONCEALED AND ENCLOSED IN THINWALL CONDUIT. SIZE AS SHOWN 5. INSTALL LIGHT SWITCHES 4' ABOVE FLOOR	DRAWN BY	KS	SHE 288 6		
	LIGHTING PANEL		CHK'ED BY		WORKSHOP BLDG 121		
	DUPLEX OUTLET		RECOMMENDED	W.E. J. [Signature]	ELECTRICAL PLAN		
	SINGLE POLE SWITCH		RECOMMENDED	W.E. J. [Signature]	SUBMITTED	DATE	2/10/67
	CEILING OUTLET		GRADE AND POSITION TITLE	CHIEF ENGINEER	BASE ENGINEER		
	MOTOR DISCONNECT	USING AGENCY		SCALE	NO.	SPEC 201-6	
	MOTOR CONTROLLER	APPROVED	[Signature]	DRAWING NUMBER 67-11/2			
	MOTOR	BASE COMMANDER	[Signature]	IN 2 SHEETS SHEET 2			
	BRANCH CIRCUIT HOME RUN TO PANELBOARD	ICP DESIGNER		DATE 2/10/67			
	2 CONDUCTOR CIRCUIT						

Figure 1-8. Electrical plan.

analyzing the trouble, and then you use the wiring diagram to determine the location of the defective part.

Exercises (205):

- When are electrical symbols used?
- Describe the symbol for an outlet.
- What is the purpose of using symbols?
- What is an electrical drawing called that shows individual wires and how they are connected to components?
- Cite the purpose of wiring diagrams.

6. From the following list of symbols and definitions, match the symbol to the correct circuit component.

- | | |
|----|--------------|
| a. | 1. Voltmeter |
| b. | 2. Switch |
| c. | 3. Cycle |
| d. | 4. Motor |
| e. | 5. Resistor |
| f. | 6. Coil |
| g. | 7. Fuse |
| h. | 8. Ground |

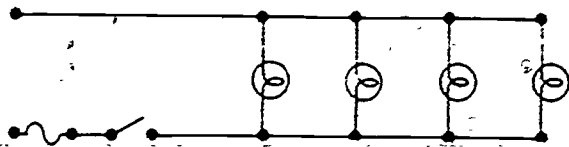


Figure 1-9. Simple schematic diagram.

206. Specify the types and uses of meters.

The heating specialist needs to know how to use the voltmeter to measure the difference in electrical pressure, the ammeter to measure the current flow, and the ohmmeter to measure resistance.

Meters are used in repairing, maintaining, and trouble-shooting electrical circuits and equipment. The best and most expensive measuring instrument is of no use to you unless you know what you are measuring and what each reading indicates. You must remember that the purpose of a meter is to measure quantities. When a meter is connected to a circuit, it must not change the conditions of the circuit.

Meters are either self-excited or externally excited. Self-excited meters operate from their own power source. Externally excited meters get their power from the circuit to which they are connected. Most common meters (voltmeters, ammeters, and ohmmeters) that you use in your work operate on the electromagnetic principle.

Meter Movements. There are several types of meter movements. However, most practical meters manufactured today use either the galvanometer movement or the dynamometer

movement. Both of these movements depend on a magnetic field produced by current flowing through the meter movement itself.

Galvanometer movement. The application of electromagnetism produced the first practical electric meter. It is called a galvanometer or D'Arsonval meter, so named after its inventor. The basic galvanometer is used to measure a very small amount of current and voltage. However, with certain modifications the galvanometer movement can be adapted for practical use in voltmeters, ammeters, and ohmmeters.

A simplified diagram of a galvanometer movement is shown in figure 1-10. The movement consists mainly of a coil of very fine wire mounted on a movable, aluminum bobbin (frame), a permanent magnet, and a pointer mounted on the bobbin. The coil and bobbin assembly is mounted on pivots which turn in tiny jewel bearings. Hairsprings are mounted on each end of the coil. The springs conduct electricity through the coil and keep the pointer at zero position when the coil is deenergized. The coil and bobbin assembly is mounted between the poles of a permanent magnet. One terminal on the meter is marked with a plus sign for a positive connection. The other terminal is marked with a minus sign for a negative connection. To connect the meter properly, the positive side of the power source (battery or dc generator) must be connected to the plus terminal and the negative side to the minus terminal.

The meter movement operates on the principle that like poles repel and unlike poles attract. When the meter is properly connected to a circuit, a small current flows through the coil. The current produces a magnetic field with a north and south pole. A fixed iron core is mounted inside the coil to insure uniform magnetic poles. These poles are in such a position that they are repelled by the poles of

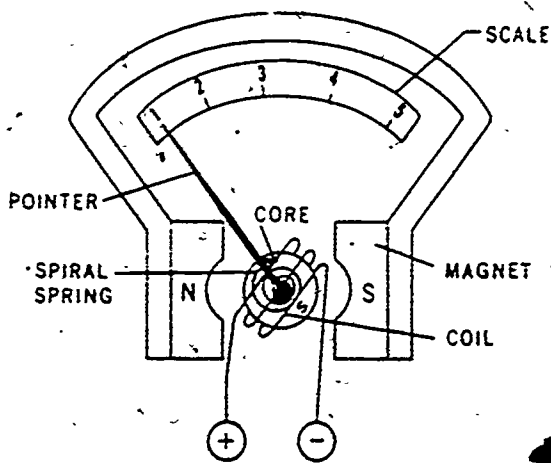


Figure 1-10. Galvanometer movement.

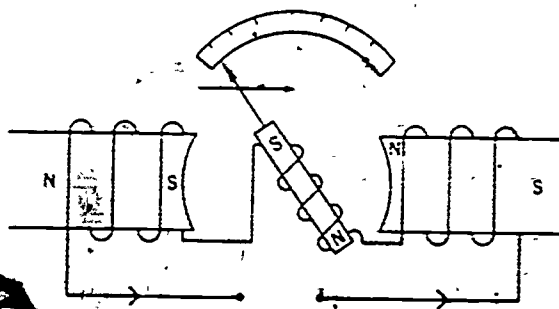


Figure 1-11. Simple diagram of a dynamometer movement.

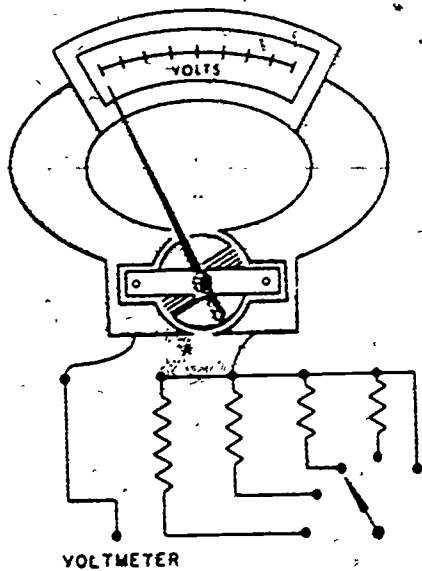


Figure 1-12. Diagram of a multirange voltmeter.

the permanent magnet. The repelling action causes the coil and bobbin assembly to turn clockwise against the tension of the hairsprings. The distance that the coil turns depends on the amount of current flow through the coil. The resistance of the coil is fixed, so current flow is determined by the voltage applied.

A basic galvanometer, like the one shown in figure 1-10, is very sensitive. It operates only in the microvolt (one millionth) or the millivolt (one thousandth) range. The full voltage from a single flashlight cell is enough to damage a basic galvanometer. For this reason, galvanometers are used only in laboratory work. As was mentioned before, however, with certain modifications the galvanometer movement is used in practical meters that you use on the job.

Dynamometer movement. A meter with a dynamometer movement uses the same basic operating principle as the galvanometer. The main difference, however, is that the permanent magnets are replaced by electromagnets. Figure 1-11 shows a simple diagram of a dynamometer movement. A movable coil to which the pointer is attached is mounted between two field coils. Notice that the movable coil is connected in series with the field coils. As current flows through the coils, opposing magnetic poles are established between the movable coil and the field coils. This causes the pointer to move clockwise. Current may enter the meter movement from either end; therefore, polarity does not have to be observed when connecting it to a circuit. You find that

current flow in either direction establishes opposing magnetic poles between the movable coil and the field coils. Their poles change according to the way the current enters. The dynamometer movement is used to measure properties of both dc and ac circuits.

Description and Use of Meters. In your study of meter movements, you learned that the movements can be adapted for use in voltmeters, ammeters, and ohmmeters. Of course, the meter movement itself is the main part of any meter. However, there is more that goes into a practical meter. All meters have cases, scales, terminals, test leads, bearings, and so on. Also, the movement itself must be protected from high voltages and high current flow.

Voltmeter. A voltmeter is used to measure the difference in potential or voltage between two points. Either of the meter movements you studied earlier may be used in voltmeters. However, the movement must contain a high resistance, called a multiplier, in series with the movable coil. The purpose of the high resistance is to limit the current flow through the meter movement. Since the resistance is fixed, the current flow and the amount of deflection of the pointer depend on the amount of voltage applied to the meter terminals.

Some voltmeters are designed to measure more than one range of voltage. These meters contain more than one multiplier, each containing a different amount of resistance. A rotary switch on the meter is moved to connect the proper multiplier into the coil circuit for the desired voltage range. A diagram of a multirange voltmeter is shown in figure 1-12.

A voltmeter is normally connected in parallel, or across the circuit or unit being tested. It has very high resistance in series with the meter movement; this will protect the meter should you read across an open circuit that is connecting the meter in series with the circuit. The scale on each voltmeter indicates whether the meter is used on ac or dc circuits. Be careful when using a voltmeter; make sure you are using it properly and that it is the proper type of meter. Polarity must be observed when you use a dc voltmeter. However, when you use an ac voltmeter, disregard polarity. Be careful not to connect a voltmeter to a source of voltage that exceeds the meter's range. When you select the voltage range, always select a higher range than the voltage you are testing. This allows the meter to reflect the voltage reading without damage to the pointer or to the meter movement. If

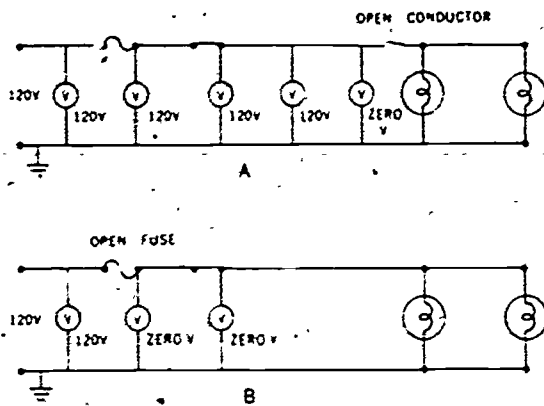


Figure 1-13. Common circuits and voltage readings.

you find that you have selected a range that is too high, select a lower range.

Voltmeters are used extensively in troubleshooting. Use a voltmeter to test all circuits to determine if they are "hot." Most electrical components are designed to operate on a specific voltage. Therefore, you must use a voltmeter to determine if the correct amount of voltage is available in various circuits. The most common trouble found in circuits that are inoperative is an open circuit. This means that there is not a complete path for the current to flow. You will find that a voltmeter is very handy when you are faced with the problem of locating an "open."

Locating an open circuit with a voltmeter is simply a matter of checking to see where voltage is present in the circuit. An open may occur anywhere in a circuit. It may be in the fuse, switch, wiring, or the unit of resistance. If power is not disconnected, voltage is present right up to the point where the circuit is open. Always start troubleshooting at the power source. If your voltmeter indicates that voltage is available, then check for voltage through the fuse and through the switch. If the fuse and switch are good, then you must check for voltage at various points along the circuit conductors. Use a wiring diagram of the circuit as a guide. The important thing is to know what voltage reading you should have at each point in the circuit. Figure 1-13 shows you two common lighting circuits, and the voltage readings obtained, at various points in each circuit. Circuit A has an open conductor. Circuit B has an open fuse. Notice the voltage readings at each point in each circuit.

Ammeter. An ammeter is another meter which makes use of the galvanometer or the dynamometer movements. However, as with the voltmeter, a device must be used with the meter to limit the current flow through the

meter coil. To measure larger amounts of current than the coil itself can safely carry, a meter shunt is connected in parallel with the coil. The current being measured divides between the coil and the shunt. Most of the current flows through the shunt, while only a very small amount flows through the meter movement itself. Figure 1-14 shows a diagram of the ammeter. Notice how the shunt is connected in parallel with the meter movement (coil). The shunt may be built into the meter, or it may be mounted externally. Meters designed to measure several ranges of current must have a separate shunt for each range. The shunts are mounted on a common terminal board and are connected to a selector switch. Setting the switch to the desired range connects the proper shunt into the meter circuit. Shunts usually contain only a small amount of resistance. A high-resistance shunt would cause too much current to flow through the meter coil and damage it.

To measure current flow in a circuit, always connect the ammeter in series with the circuit. Never connect an ammeter in parallel with a voltage source—to do so will damage the meter. Use only a dc meter in dc circuits and observe polarity. Use only an ac meter in

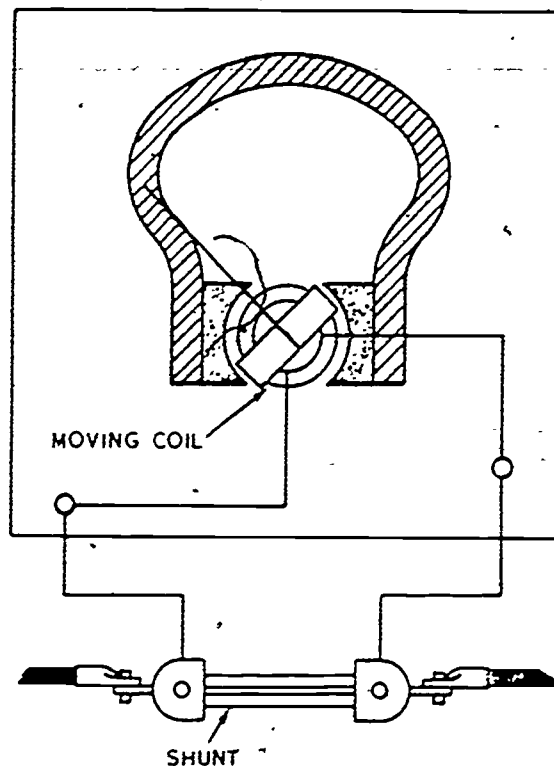


Figure 1-14. Diagram of an ammeter.

ac circuits. Polarity need not be observed when you use ac meters. Make sure each meter you use has a range large enough to keep the pointer deflection less than full scale. When measuring current flow, start with the highest range on the meter and work down until you reach the appropriate one. Many a low-capacity ammeter has been damaged by attempting to measure current in a high-capacity circuit. Be sure to read the lettering on the meter scale or switch positions and select the proper range before you connect an ammeter in a circuit.

Ammeters are used in troubleshooting and analyzing circuits and circuit components. Suppose you wanted to select a fuse for a particular circuit. What do you base your selection on? Fuses or other protective devices for a circuit must be selected on the basis of current flow. You can, of course, determine the current flow in a circuit by computing the wattage of each circuit component. However, the simplest method is to connect an ammeter in the circuit. You then can read the total current flow through the circuit directly from the ammeter scale. Select the proper fuse or other protective device based on the ammeter reading. Figure 1-15 shows you how an ammeter is connected to give you the total current flow through a circuit.

Ohmmeter. An ohmmeter is used to measure the amount of resistance in a circuit or in circuit components. The resistance of a circuit is one of the factors that determines its proper operation. In addition to measuring resistance, the ohmmeter is useful in checking continuity in a circuit. Continuity simply means a continuation or continuous path. Often when troubleshooting a circuit, you cannot readily make visual inspections of all parts of the circuit. Therefore, it is difficult for you to determine if a circuit is complete, or if current may be flowing in the wrong part of the circuit. The best method of checking a circuit for these conditions is to send a small current through it.

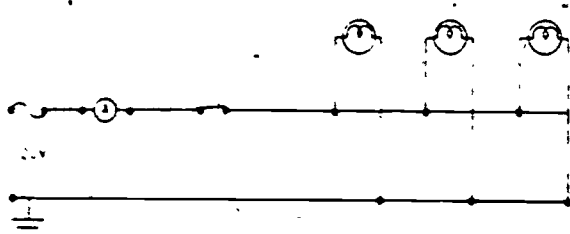


Figure 1-15. Ammeter connections.

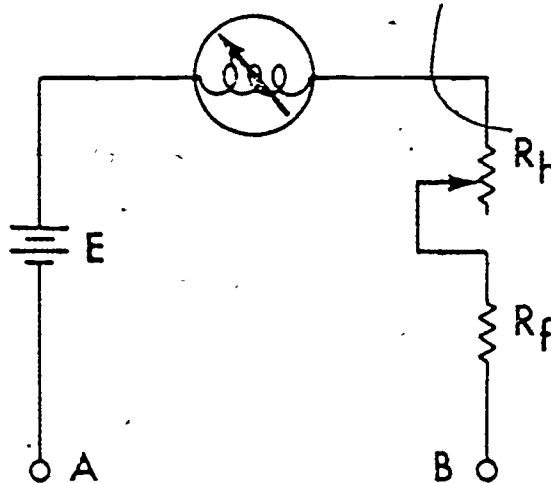


Figure 1-16. Ohmmeter circuit.

If the conductors make a complete circuit, current will flow through the circuit. The ohmmeter is the ideal instrument for checking circuits in this manner. It provides the power to cause the current to flow and the meter to indicate the amount that is flowing. To make the check, first study the circuit diagram, and then check each part of the circuit with an ohmmeter. The ohmmeter is used to check circuits for opens, shorts, and grounds.

The basic meter movements that are used in voltmeters and ammeters are also used in ohmmeters. A basic circuit of an ohmmeter is shown in figure 1-16. It consists of the following:

- (1) A source of dc power, usually a small dry cell.
- (2) The basic meter movement.
- (3) A variable resistance R_h (rheostat) to zero the meter.
- (4) A fixed resistance R_f to limit the current flow through the meter coil.

Voltmeters and ammeters are used in live circuits, but you should never connect an ohmmeter to a live circuit. To do so will surely ruin the meter movement. As shown in figure 1-16, with terminals A and B connected together, there is no resistance between them. The current through the circuit causes a full-scale deflection of the pointer. Since there is zero resistance between A and B at full-scale deflection, this point on the scale is marked by the number zero. In the event the pointer does not read zero resistance when A and B are shorted together, the most probable cause is a low battery (E). By adjusting the rheostat (R_h), you can bring the pointer to

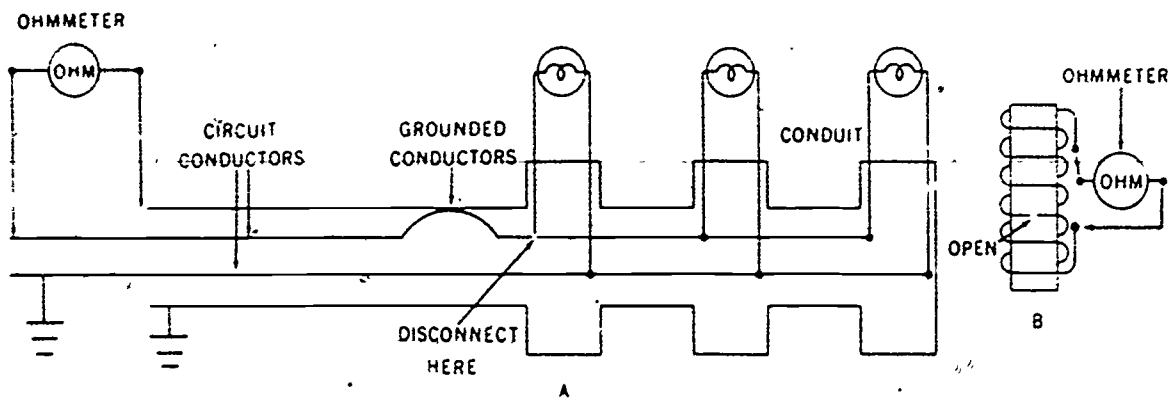


Figure 1-17. Ohmmeter connections

the zero position. Before you use an ohmmeter, always adjust the pointer to zero.

When a unit of resistance is placed between A and B, the pointer does not deflect to zero. This is because the added resistance decreases the amount of current flow through the circuit. The deflection of the pointer is directly proportional to the amount of resistance between A and B. When you increase the resistance, the pointer shows less deflection.

Because it contains its own power supply, an ohmmeter is handy for troubleshooting circuits and components. Shorts, grounds, and opens are easily detected with an ohmmeter. Figure 1-17 shows how you may use an ohmmeter to detect faults in circuits and components. In detail A of figure 1-17 you see a typical lighting circuit enclosed in conduit. The circuit is accidentally grounded to the conduit. Of course before you start troubleshooting, isolate the entire circuit by disconnecting it from the source of power. Next, isolate each section of the circuit by disconnecting the conductors at the junction boxes. Test each conductor for grounds by connecting the ohmmeter test leads, one lead to the conductor and the other lead to the conduit. Where the conductor is grounded to the conduit, the ohmmeter reads zero ohms. This reading indicates that particular conductor is bad and must be replaced. You also can check the circuit conductors for shorts in much the same manner. Simply isolate sections of the circuit by disconnecting both of the circuit conductors at the junction boxes. Then, connect the ohmmeter leads, one lead to each conductor. If the conductors are shorted together, the ohmmeter indicates zero ohms. If the conductors are not shorted, then the ohmmeter reads infinity. Infinity means that the resistance is so great that it cannot be measured.

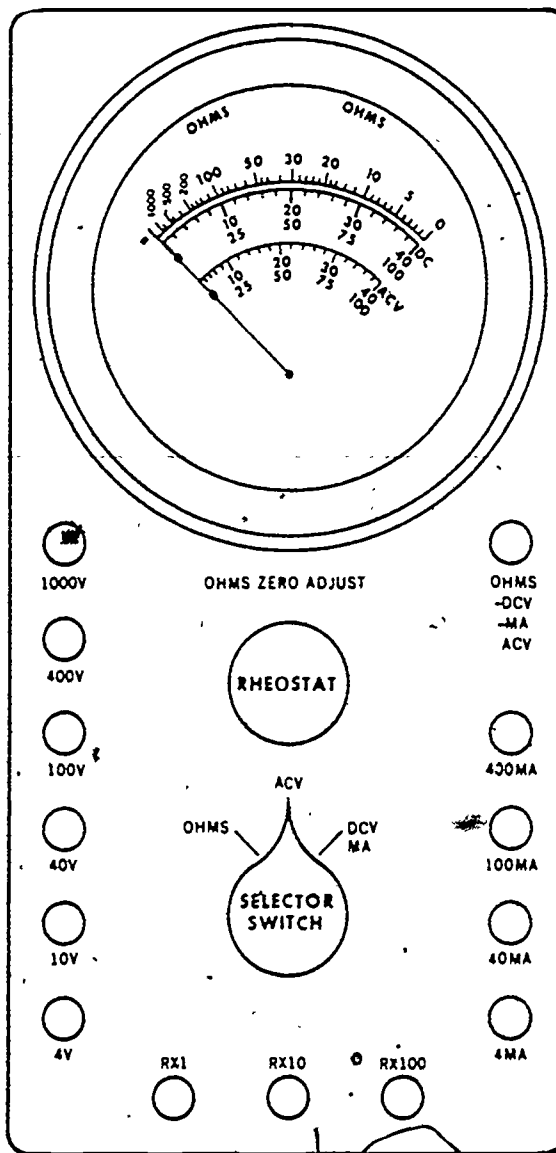


Figure 1-18. Common multimeter.

Detail B of figure 1-17 shows an ohmmeter connected across an electromagnet. You can check most electrical components as well as complete circuits for opens in this manner. Notice that the coil is open. The ohmmeter, when connected as shown in the figure, indicates infinity. If the coil were not open, then the ohmmeter would indicate continuity; or more specifically, the ohmic resistance of the coil itself.

The most common meter normally available to the heating specialist is the multimeter.

The multimeter is a combination of a voltmeter, ohmmeter, and ammeter in one unit, with only one meter movement. Each multimeter consists of a basic meter movement combined with additional devices to serve a specific purpose. Shunts are used for the ammeter, multipliers for the voltmeter, and resistors and a battery for the ohmmeter. By proper arrangement of these devices, along with switches and jacks (plug-in connections), the multimeter can be built into a small, compact unit.

Figure 1-18 shows one common type of multimeter. Notice the two knobs on the face of the meter. One is the zero adjust knob for the ohmmeter scale, while the other is called the selector switch. By using the selector switch, you can use the meter as an ohmmeter, an ac voltmeter, a dc voltmeter, or a dc milliammeter. This particular multimeter cannot be used to measure a current flow above 400 milliamperes; however, it measures up to 1000 volts.

The multimeter comes equipped with two test leads—one black and one red. The black test lead goes in the jack located at the upper right-hand corner on the meter. This jack is called the common jack. The position of the red test lead depends on how you use the meter. When you measure voltage, place the red test lead in one of the jacks on the left side of the meter. Place the selector switch to DCV when measuring dc voltage, and to ACV when measuring ac voltage. When the voltage you are measuring is unknown, use the 1000-volt jack. Once you find what the voltage is, change to the jack just above that voltage for greater accuracy. If you want to measure milliamperes, place the red test lead in the jacks on the right-hand side of the meter. Place the selector switch to MA. When making a continuity check or measuring resistance, place the selector switch to OHMS and place the red test lead in one of the jacks at the bottom of the meter. When you finish using the meter, always place the selector switch to ACV or DCV position. Since the

ohmmeter circuit is powered by a battery, the battery discharges if the selector switch is left in OHMS position.

Notice in figure 1-18 that the scales on the meter are labeled ACV, DCV, and OHMS. You use the dc scale for measuring dc voltage and milliamperes. Looking at the ac scale, you see that there is a 100-volt and a 40-volt scale. When you use the 4-volt jack, you read the voltage on the 40-volt scale and subtract the zero from that scale. Should you use the 10-volt jack, you read the voltage on the 100-volt scale and subtract a zero from each figure on that scale. When you use the 100-volt jack, read the voltage on the 100-volt scale and do not add or subtract a zero from the figures.

When you use the ohmmeter portion of the multimeter, always short circuit the test leads together and adjust the meter to zero ohms. This compensates for battery loss and internal resistance. Notice that the ohms scale reads from right to left. All other scales read from left to right. Notice at the left end of the ohms scale the symbol for infinity (∞). This means that when the pointer deflects to this position, the resistance is an infinite amount (too much to measure).

Exercises (206):

1. What is the purpose of meters?
2. What is meant by a self-excited meter?
3. Name the individual meters that the multimeter is composed of.
4. What is the purpose of short circuiting the test leads and zeroing the meter when using a multimeter to measure ohms.
5. What portion of the multimeter do you use to measure the electrical pressure?
6. What is the voltmeter, ammeter, and ohmmeter used for?

207. State some problems to look for in troubleshooting electrical circuits.

Trouble with a heating unit often involves electrical problems. The heating specialist should be able to troubleshoot electrical circuits. He can simplify his problem by determining if the malfunction is electrical or mechanical. Troubleshooting can be defined as a systematic method of locating faults in an electrical circuit."

When you troubleshoot circuits, the first thing to do is inspect the circuit visually. Check for loose connections, loose wires, abraded wires, and type of wiring.

Loose Wire Connections. The root of most circuit trouble is loose connections. While checking a circuit, a heating specialist frequently finds it necessary to disconnect terminals at various points. He should take extreme care to tighten the terminals when he reconnects the wires. Loose connections cause arcing and can in time necessitate an assembly replacement. Furthermore, loose connections can lead eventually to electrical shorts and grounds which may cause fires. When you replace terminals, be sure to clean them well and tighten them securely. Loose connections cause interference in electrical transmission and receiving equipment. Also, increased resistance resulting from a loose or poor connection increases the voltage drop in the circuit, causing inefficient operation of the devices in the system.

Abraded Wire. Look for loose and abraded wires. Usually, a loose wire has sufficient movement to wear off the insulation if it rubs against a solid object. Fasten all loose wires securely and replace any with poor insulation. Poor wire insulation can cause shorts and grounds; and, as we have already pointed out, shorts and grounds can cause fires and injury to personnel.

Type of Wire. During your inspection, be sure to check the type of wire for the particular circuit. If the circuit is in a dangerous place, only wire approved for this location should be used. The code usually specifies threaded rigid metal conduit or MI (mineral insulated) cable. If you find that the wiring is of the wrong type, replace it.

Loose Fittings. To avoid the possibility of short circuits, periodic checks should be made of the electrical fittings. These fittings include such items as conduit couplings, connectors, and box-entry devices. Check the fittings for looseness and separation and tighten them or reclamp the conduit when necessary. Conductor or conductor-enclosure supports

84
should also be inspected and tightened if necessary, to insure a trouble-free operating system.

Capacity. An overloaded circuit is a serious problem. Many times the electrical demand on a circuit is so great that the circuit fuses blow or the circuit breakers trip. In some cases, with the wrong fuses or circuit breakers, the wires overheat and burn off the insulation. This condition causes shorts and grounds and sets up potential fire hazards. Be sure to check the capacity of a circuit before you connect high wattage appliances and equipment to it. Always determine the amperage of the equipment before plugging it into a circuit outlet. Determine the capacity of the circuit by checking the size of wires and the fuses or breakers. If the amperage of the equipment is greater than the circuit can carry, then the equipment must not be operated from that circuit. If the capacity of the circuit is greater than the equipment requires, then its operation from the circuit is safe. This procedure assures that a circuit is carrying a safe load.

Many times you may want to add oversize lamps to circuits, or plug in electric heaters or other appliances and equipment. When adding these units, be sure the circuit will carry the load. If you find that a circuit is overloaded because of a demand for power, you must transfer part of the load to another circuit.

Many times a visual inspection does not uncover an apparent problem; therefore, you must advance to troubleshooting with meters. Remember that we discussed the use of meters in learning objective 206. In electrical troubleshooting, you will use voltmeters, ohmmeters, ammeters, and test lamps or the meter that incorporates many meters, the multimeter.

The voltmeter requires that the power be connected to the circuit before testing, while the ohmmeter cannot be used on an energized circuit. The voltmeter tests are started at the power input end of the circuit, whereas the ohmmeter tests are started at the ground end of the circuit. If you repeatedly apply effective troubleshooting procedures, you will develop a skill that is useful in everyday life as well as in the Air Force. Electrical circuit troubles develop either in the wiring or in the operating unit. If the problem is carefully analyzed and systematic steps are taken to locate it, not only much time and energy are saved but also damage to expensive equipment can often be avoided.

Testing with instruments can be carried out on either "dead" circuits or "live" circuits.

Circuit defects can sometimes be more easily located by one method or the other, depending upon the type of circuit and the trouble.

Dead Circuits. When you are testing dead circuits, disconnect the device from the outlet or disconnect switch. Equipment for this method of testing includes such units as ohmmeters and battery-powered test lamps. A suitable continuity tester can easily be made from a flashlight in an emergency. An ohmmeter (which contains its own batteries) is excellent for continuity testing. A basic factor in choosing continuity testing equipment is to use relatively low-voltage instruments, reducing the danger of sparking. When connections are made in the presence of combustible vapors, sparking is a serious fire hazard.

Live Circuits. When live circuits are tested, the circuit under test is energized in the conventional way from the power source. A voltmeter or a test lamp is generally used. Make certain that the voltmeter or test lamp is designed for the type of current to be tested and has a scale of adequate range. A test lamp should have low wattage, and its voltage rating should be the same as that of the circuit being tested. You can make a test lamp by connecting two pieces of insulated copper wire to the terminals of a lamp socket and removing a quarter of an inch of insulation from the wire ends which serve as the test probes. When testing live circuits, make sure all power is removed from the circuit before making the necessary circuit changes; then reapply the power. **CAUTION:** Be extremely careful when you use this method of testing because live points of the circuit are exposed when the junction box covers are removed.

Open Circuits. An open circuit occurs in a wiring system when one or more conductors in a circuit is broken or otherwise separated. During operation, an open circuit is determined by the nonoperation of a part or all of an electrical circuit, even though the fuses may not be blown. Use the following maintenance procedure for locating the source of the trouble:

- a. Initially you should make a visual check for a broken or loose connection at the first dead (nonoperating) outlet in the circuit. If a defective connection is found, tighten or repair the connection.
- b. If the trouble or "open" is not found by a visual check, use a voltmeter to determine whether or not the circuit is live (operating) up to the point of the outlet.
- c. When the circuit is open between the

outlet and the fuse in the power panel, use the voltmeter to determine which wire is open. If the test prods have been placed between a phase or hot wire and the conduit, cable sheathing, or ground connection, and no voltage is present, the phase or hot wire is open. If the phase or hot wire is live up to the outlet, the neutral or ground lead may be open.

Short Circuits or Grounds. A short circuit results when two bare conductors of different potential come into contact with each other. If a conductor inadvertently contacts a metallic part of a wiring system, such as a motor frame or conduit, the system is sometimes said to be grounded instead of having a short circuit. Grounds or short circuits can be (1) solid, (2) partial, or (3) floating. This presents a serious safety hazard, since the operating machinery can still be in use and have a short circuit. This situation is especially true in motors and some appliances.

A solid ground or short circuit is one in which a full voltage test is obtained across the terminals of a blown fuse when the load is disconnected from the circuit. The circuit resistance in this case is very low and the current is very high, so that the fuse will blow.

A partial short or ground is one in which the resistance between each of the phase wires or between the phase wire and the ground is partially lowered but still remains high enough to prevent enough current to blow the fuse. Grounds of this type are generally more difficult to locate than are solid grounds.

A floating ground is a condition in which the resistance of the defect in a system varies from time to time. Grounds of this type may be present in an electrical system for some time before their existence becomes known. A floating ground is indicated when fuses are blown on the phase side of a circuit a number of times, and a circuit test shows no defects in the system. In grounds of this type, fuse trouble may not occur for several days. Then the ground reappears, and the fuses are blown again.

Exercises (207):

- 1. In a visual inspection of a circuit, what specifically do you look for?
- 2. When using meters to troubleshoot a circuit, state some of the problems you may encounter.

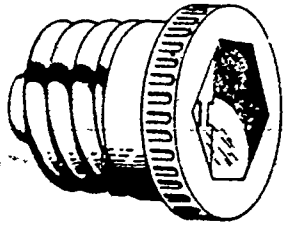


Figure 1-19 Screw-in type fuse.

208. Cite the types of protective devices found in an electrical circuit.

As determined from Ohm's law, if the resistance is extremely small, the current will be extremely great. For this reason a great deal of trouble is caused by a short circuit such as results, for example, when the wires to a motor become bare and touch each other. Not only does the motor fail to run (because practically all the current is going through the short) but if a protective device—such as a fuse, circuit breaker, or a circuit protector—is not in use, there is danger of fire.

Fuses. A fuse is a strip of metal having a very low melting point, which is so connected that all of the current in the circuit flows through it. An alloy of tin and bismuth is used in most fuses. A fuse will melt and break the circuit whenever the current becomes excessive. The types of fuses most used in the Air Force are the screw-in type and the cartridge type. See figures 1-19, 1-20, and 1-21. Since a fuse is a protective device, it is very important to use one that fits the need of the circuit in which it is to be used. When a fuse is replaced, it is necessary to check to see if the fuse is the correct type and capacity. All fuses are hooked in series; consequently, a fuse must not be installed in the ground side of a circuit.

Circuit Breakers. A circuit breaker is a device that breaks the circuit when the current reaches a predetermined value. It is often used in place of a fuse and sometimes eliminates the need for a switch. The feature which distinguishes a circuit breaker from a



Figure 1-20. Blade type fuse.



Figure 1-21. Cartridge type fuse.

fuse is the fact that a circuit breaker can be reset, while a fuse must be replaced. Several types of circuit breakers are used by the Air Force. Figure 1-22 represents a typical circuit breaker panel. One is a magnetic type, which operates by the pull of an electromagnet on a small armature which trips the breaker. Another type is the thermal-overload breaker or switch, a bimetallic strip which, when it becomes heated, bends away from a catch on the switch liner and permits the switch to trip open.

Some circuit breakers have to be reset by hand, while others are automatic. When a manual-reset type of circuit breaker trips to the OFF position, it is necessary to move it back to the ON position to put the circuit back in operation. An automatic type of circuit breaker resets itself. If the overload is still present, the circuit breaker will again trip without damage to the circuit.

Circuit Protectors. The circuit protector is a device which automatically opens the circuit whenever the temperature of the associated unit becomes excessively high. It has two positions, automatic OFF and automatic ON, and it is most often used with motors. If an inoperative part causes the temperature of the motor to become excessively high, the circuit protector breaks the circuit. The operation of the circuit protector depends upon a bimetallic disc or strip which bends and breaks the

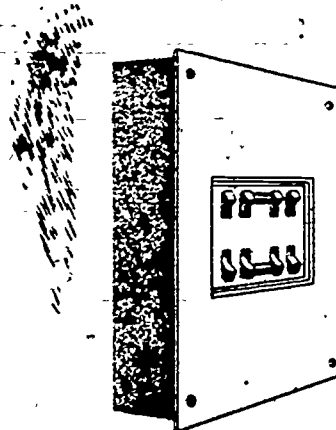


Figure 1-22. Typical circuit breaker panel.

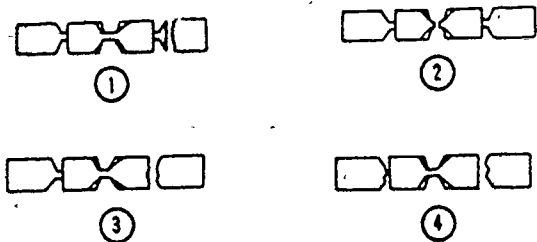


Figure 1-23. Blown fuse links.

circuit when heated. Upon cooling, the bimetal disc or strip assumes its original position and closes the circuit.

Most electrical devices are rated according to the voltage that should be applied to them and also according to the power they require. For example, one lamp might be rated as a 115-volt, 40-watt lamp, while another is rated as a 115-volt, 20-watt lamp. This means that both lamps are to be operated on a 115-volt circuit, but twice as much power is required to operate the first lamp as the second.

You can find the wattage of an electrical unit—that is, the power it requires—by multiplying the current flowing through it by the voltage applied to it. Thus, a starter motor using 70 amperes with a pressure of 24 volts uses 1,680 watts of electrical power. To convert wattage to horsepower, divide by 746. Thus, by dividing the 1,680 watts by 746 (the electrical equivalent of 1 horsepower), you will find that the starter motor mentioned before will develop approximately 2 horsepower.

Exercises (208):

1. What are the most common types of protective devices found in an electric circuit?

209. Give the procedures for checking fuses and circuit breakers.

Check the distribution panel for cleanliness. Remove all scraps of wire, pieces of insulation, nuts, bolts, screws, or any other objects left in the panel. All connections should be tight. Properly made connections seldom loosen unless they have been subjected to severe vibration. Correct improperly soldered connections when you discover them, to avoid future trouble.

Fuses should be checked for discoloration. Portions of a fuse making good contact are

clean and bright. If the contact has been poor, air gets to the contact surface and heating the fuse produces oxidation, shown by discolored surfaces. But no matter how much a fuse is heated, little oxidation occurs if a good contact exists. When only one end of the fuse has a badly oxidized contact surface, poor contact positively exists at the end where the discoloration is. Oxidation on a bottom contact or a plug-type fuse indicates a poor contact because the fuse was not screwed down tight. If the washer or end ring on a ferrule-contact fuse is burned or partially melted, the cap was not screwed down tight. Charred ends of the fiber tubes on nonrenewable or renewable fuses always mean poor or inadequate contact. The poor contact may be caused by abuse or lack of proper attention to fuse clips and fuse blocks. When only one end of the fuse is charred, poor contact is at the charred end.

Figure 1-23 illustrates fuse links blown under four different conditions. The first is a result of poor contact; the blow is between the reduced portion and the end of the link. The second is a normal blow when contact was good; the third is also normal, indicating a light overload. The fourth shows the result of a heavy overload or short circuit.

Knife-blade switches should be checked for full alignment with contacts. If contact is not complete, the carrying capacity is reduced and the switch will probably heat.

Check the ground connection to insure that it is clean and tight. All components within the panel and also the panel itself should be checked for corrosion.

Circuit breaker switches have an advantage over the fuse-type switch. When an overload occurs, the circuit breaker automatically opens the switch. To reclose the switch, you simply reset the breaker. You do not have to remove and replace blown fuses.

Exercises (209):

1. Oxidation of fuses is normally caused by what discrepancy?
2. If a fuse does not show any visible means of being blown, how would you check its usability?
3. What are the procedures for checking fuses and circuit breakers?

Electrical Controls

AUTOMATIC CONTROLS enable man to complete his tasks better and at a lower operating cost than if the same work were done with manual controls. Their application is widespread. Uses range from the simple controls in home appliances and automotive devices through domestic heating and commercial comfort air conditioning to commercial and industrial process controls.

energy source could be electricity. More complex systems are simply a group or groups of suitable coordinated basic control systems.

210. Name the types of electrical controls.

2-1. Use of Electrical Controls

A basic control system consists of a controller, distribution system, a controlled device, and the energy source necessary for the operation of these devices. For example, the controller may be a room thermostat, the operator may be a damper operator, and the

There are many devices that may be used in an electrical control system. Lets look at some of the more common devices found in heating systems control circuits.

Electrical Switches. These devices in heating-control equipment operate electrical circuits in response to signals from automatic-control units. In other words, the actions initiated by temperature, pressure, and humidity devices change, open, or close switch contacts. These, in turn, control the operation of the heating plant through

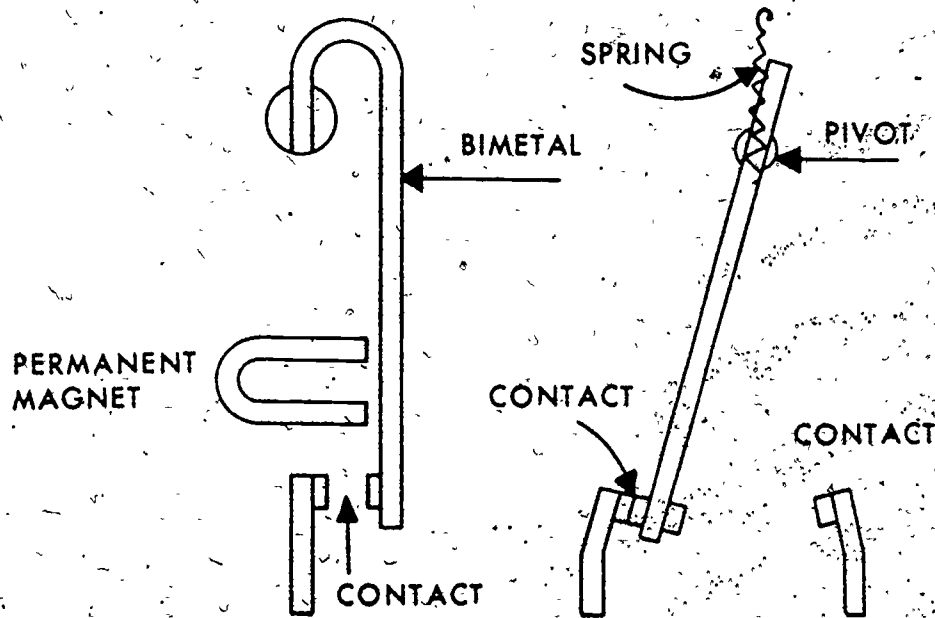


Figure 2-1. Snap-action type switch.

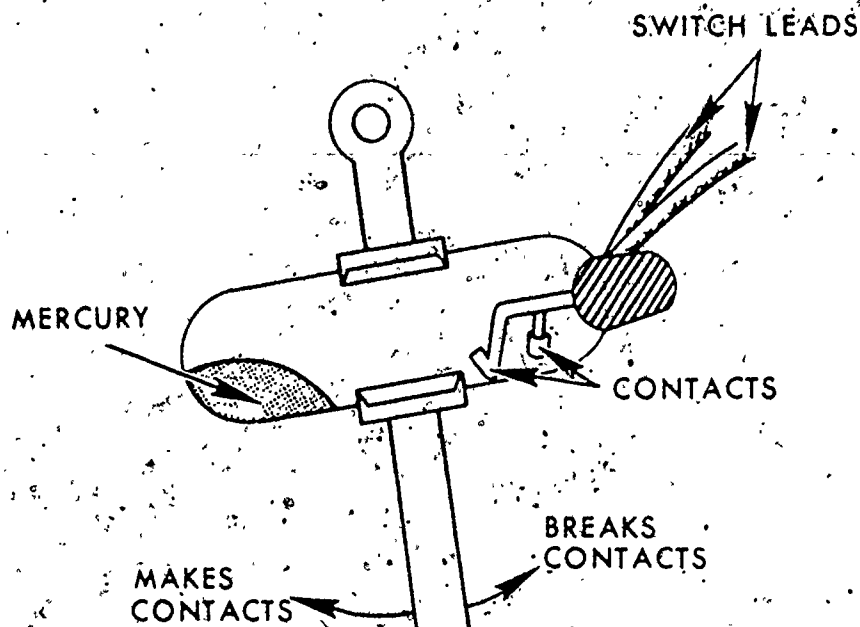


Figure 2-2. Mercury type switch.

electrical circuits. Switches with which you will work may be either the snap-action type or the mercury type.

Snap-action type. Snap-action switches vary in their designs. Some are constructed so that they have an over-center spring arrangement that is designed so that the movement of the actuating lever engages the spring and causes the switch to move with snap action. This snap-action type of switch is shown on the right in figure 2-1. Another snap-action switch shown in figure 2-1 has a small magnet that causes the electrical contacts to remain firmly closed. It also provides the switch with the snap-action effect. The contacts of this switch must open or close quickly to avoid excessive arcing across the points. Arcing burns the contacting surfaces, which eventually causes switch failure.

Mercury type. A mercury switch is one that has the electrical contacts and a small amount of mercury in a hermetically sealed short glass tube, such as that shown in figure 2-2. Tilting the switch causes the mercury inside the tube to cover or uncover the contacts. When the contacts are covered, the electrical circuit is completed through the mercury column.

Every electrical switch is designed so that it has a specific rated capacity, usually in amperes and volts; for example, a capacity of 8 amperes at 110 volts. An electrical switch should never be overloaded, because overloading causes overheating, which

eventually results in switch failure that can create a fire hazard.

Relays. There are many kinds of relays used in electrical applications. The type we are interested in is the control relay. These are the relays that open and close an electrical circuit of higher voltage by use of a lower voltage. They may also be defined as electrically operated switches. The main purpose for this type of relay is to remotely control some electrical device such as a motor for a pump or fan. A control relay that operates a motor is shown in figure 2-3.

Control Transformers. A control transformer steps voltage down so that the voltage may be used to operate different kinds of electrical controls. The relay in figure 2-3 operates on 24 volts ac. The power coming to the switch box S-2 is 110 volts, which is too high. The control transformer reduces the 110 volts to 24 volts to properly operate the relay.

Line voltage applies to wiring or electrical devices using 110 or 220 volts. In automatic control terminology, low voltage applies to wiring or electrical devices using 24 volts or less. Many heating controls use from 20 to 25 volts ac. The control transformer in figure 2-3 is used to obtain this low-voltage supply.

Magnetic Starters. Three-phase motors must have at least two of the hot conductors interrupted to stop their operation. Usually, all three conductors are interrupted (opened) when the motor is stopped. The device that

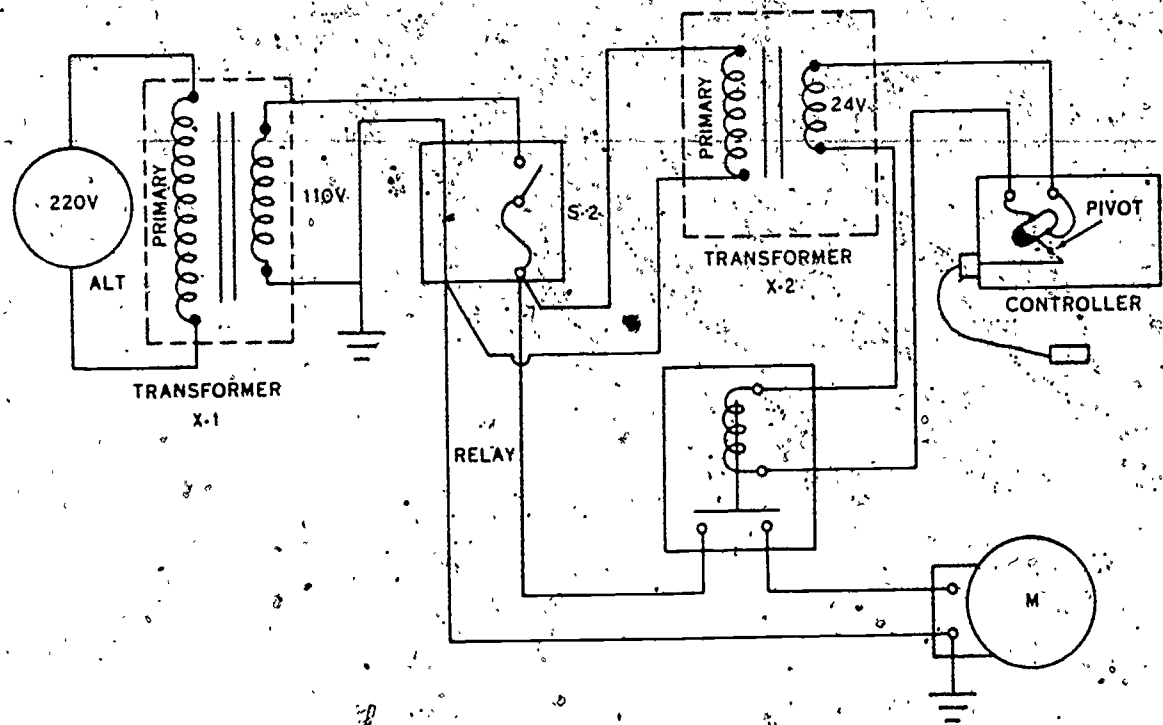


Figure 2-3. Control relay.

opens these conductors (wires) is called a line starter or a magnetic starter. It is nothing more than a larger control relay which electrically operates two, three, or more switch contacts. Figure 2-4 shows a magnetic starter which is controlling the power to a three-phase motor.

The circuit control in this situation is line voltage which differs from the previous situation, in which a control transformer was used to lower the voltage. Most controls, such as the thermostat in figure 2-4, are rated as to their operating voltage. In some cases they may be rated as 220, 110, or 24 volts, as you will see later when we discuss some of the electric controls.

Exercises (210):

1. How is the circuit completed in a mercury switch?
2. Explain the function of a control transformer.
3. What is the purpose of a relay?

4. Why must the contacts open and close quickly on a snap-action type of electrical switch?
5. Name some types of electrical controls.

211. Specify the thermostat installation location, define a primary control, and identify necessary equipment for replacing an aquastat.

Automatic controls are used on heating systems to accomplish varied missions. These controls function in response to either temperature, pressure, or humidity. They provide safety protection by preventing operation of mechanical equipment when such operation would be dangerous or hazardous. The main elements of electrical control systems are thermostats, aquastats, primary controls, and limit controls.

Temperature-Responsive Devices. Many automatic control units such as the

thermostat, limit control, fan switch, etc., must be responsive to temperature changes. A temperature change actually causes the electrical contacts within each unit to open and close. This action is an indicating signal that is transmitted to the primary control for specific action, such as starting or stopping the operation of the heating plant.

Bimetallic strip. An automatic control unit is sometimes equipped with a straight bimetallic strip to open and close the contacts. The strip is made by bonding together two pieces of dissimilar metals such as brass and invar, as shown in figure 2-5. Below a certain predetermined temperature, this strip does not deflect or bend. However, when the strip is heated, it will tend to bend in the direction of the expansion of the metal which has the least amount of expansion, as shown in figure 2-6. Actually, an electrical switch is constructed, as shown in figure 2-7, by welding two electrical connections and contacts to the arrangement. This switch can be used to control the electrical circuit by responding to temperature changes. This is

the basic principle of operation for many temperature-responsive automatic units. Some automatic units, however, can be operated by a bimetallic strip in the form of a spiral, a U-shape, a Q-shape, or even in the form of a helix, as shown in the illustrations in figure 2-8.

The vapor-tension device. The vapor-tension principle is used to operate some types of automatic control units. This is a commonly-used type of temperature measuring device, in which the effects of temperature changes are transmitted into motion by means of a highly volatile liquid. The most used vapor-tension device of this type is the simple compressible bellows, such as that shown in figure 2-9. It is made of brass and is partially filled with alcohol, ether, or some other highly volatile liquid not corrosive to brass. When the temperature around the bellows increases, the heat gasifies the liquid, causing the bellows to expand and close a set of electrical contacts. When the bellows cool again, they contract and open the electrical contacts. See figures 2-9 and 2-10.

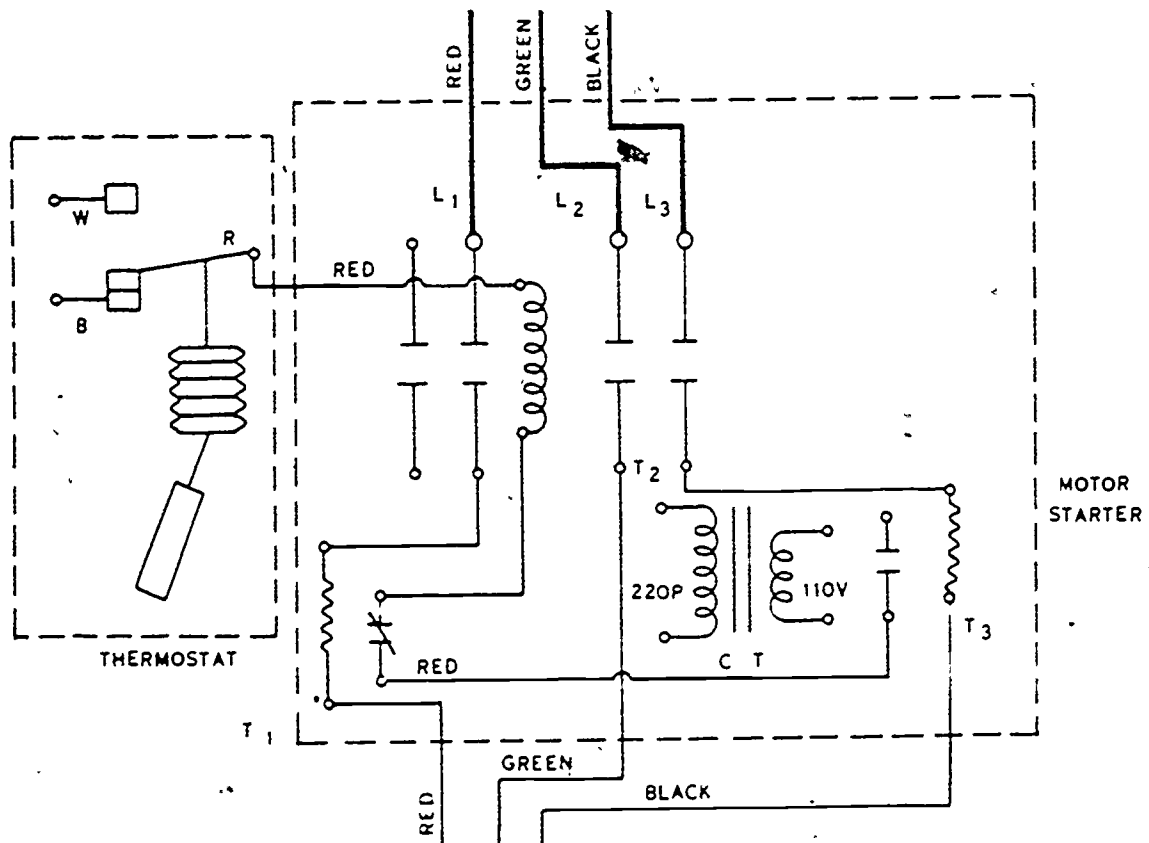


Figure 2-4. Magnetic starter.

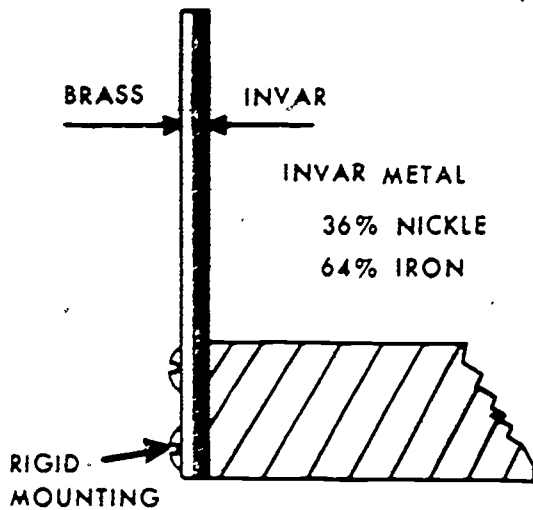


Figure 2-5. Bimetallic strip.

The remote-bulb device. All liquid-filled devices are not limited to just the simple bellows such as that described above. There are also remote-bulb types of devices that not only have a bellows, but also have a capillary tube and a liquid-filled bulb, such as that shown in figure 2-11. When the liquid in the bulb is heated, part of it gasifies and forces its way through the capillary tube into the bellows. The increase in pressure inside the bellows causes them to expand and open or close a set of electrical contacts. When the bulb cools, the gas liquefies and causes a decrease in pressure in the bellows. This

action allows the bellows to contract and open or close the set of electrical contacts.

Pressure-Responsive Devices. Pressure-responsive devices are incorporated in heating units in the form of pressure controls, pressure gages, pressure regulators, etc. One type of pressure-responsive device uses the action of a bellows similar to that of the remote-bulb device, mentioned previously. In this case, however, the bellows expands and contracts in response to changes in pressure. The action caused by movement of the bellows opens or closes a set of electrical contacts.

Humidity-Responsive Device. Humidity-responsive devices are regularly used to cause the opening or closing of the solenoid or motorized valves which control the flow of water or steam to the humidifying equipment. The sensitive element which actuates the motion in this device normally consists of a group of human hairs. These hairs lengthen when the humidity is high and shorten when the humidity is low.

Thermostats. The thermostat is a temperature-sensing device that responds to changes in ambient temperature and reacts to them by sending a suitable signal through the aquastat to the primary control, circulating pump, or control valve to start water circulation.

A thermostat must be installed where it will register, as closely as possible, the average ambient temperature that is to be controlled. It will not operate satisfactorily unless free air circulates around its temperature-sensing

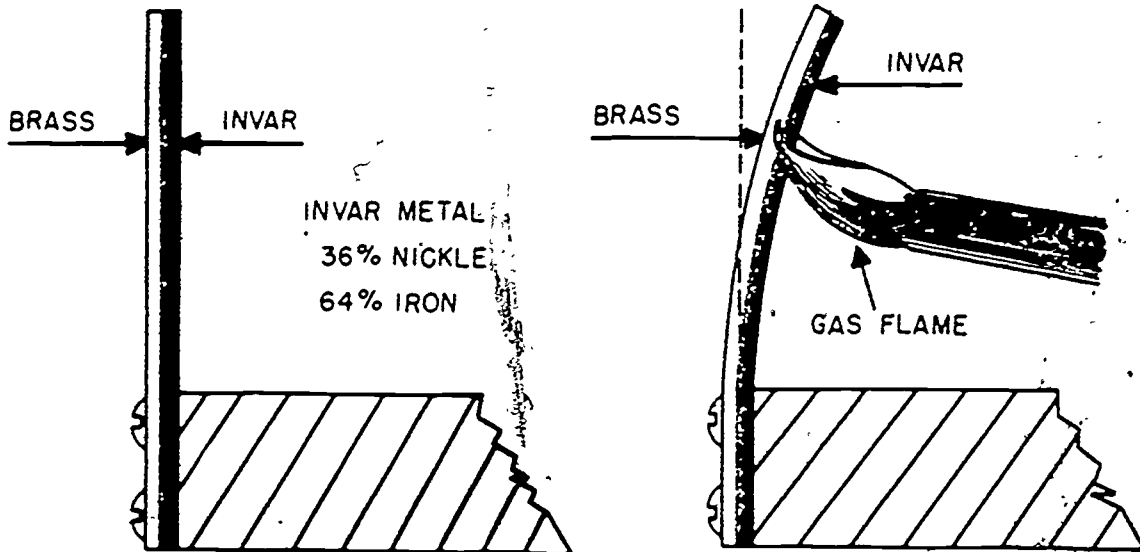


Figure 2-6. Bending of bimetallic strip.

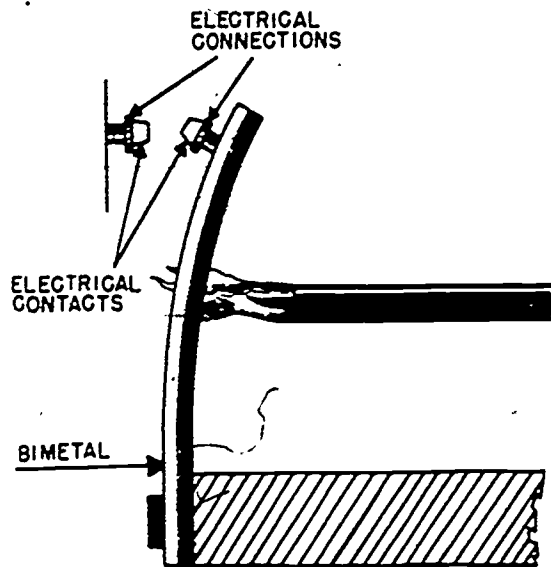


Figure 2-7. Bimetallic electrical switch.

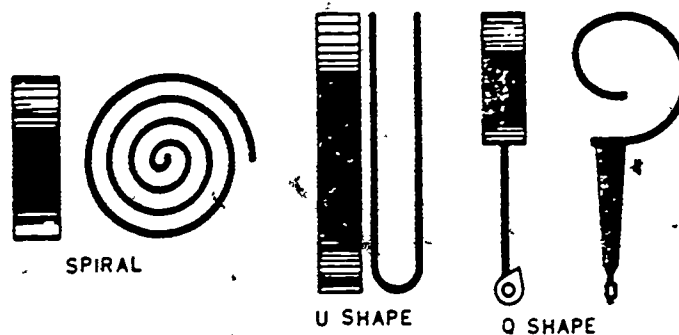
element. A good location for a thermostat is 4 or 5 feet from the floor on the inside wall of a representative room or on a centrally located, supporting post or column in a barracks. Do not mount a thermostat where it can be affected by heat from lamps, sunlight, fireplaces, radiators, or similar sources, or by cold drafts from windows and doors. Do not place it where temperature change is extremely slow, as in central halls with poor

air circulation, for example. Do not place it on outside walls. Do not permit a thermostat to be used as a coat or hat rack.

Aquastat. The aquastat controls the water temperature. When the temperature of boiler water changes, it sends a suitable signal to the primary control. The aquastat must be located where it is exposed to the true boiler water temperature. It must be mounted in an immersion well.

Primary Controls. Primary controls are actuating devices that operate firing equipment in response to signals received from the aquastat or thermostat. Often a primary control is a simple switching device, which closes and opens the main circuit. More frequently, however, it consists of relays that control several types of operating devices.

Limit Controls. Limit controls shut down the heating equipment when the temperature of the heating medium becomes excessive and are essential elements of the temperature control system. Limit controls for hot-water installations are nothing more than aquastats. Air Force installations generally use immersion-type aquastats, which can be installed in the boiler or in a vertical riser. The aquastat usually consists of a bimetallic element that operates in response to temperature changes and in accordance with the temperature setting. The bimetallic element is inserted into the immersed copper



ROTATION ON TEMPERATURE INCREASE



HELIX
RIGHT-HAND WOUND

ROTATION ON TEMPERATURE INCREASE



HELIX
LEFT-HAND WOUND

CG-002A

Figure 2-8. Various types of bimetallic strips.

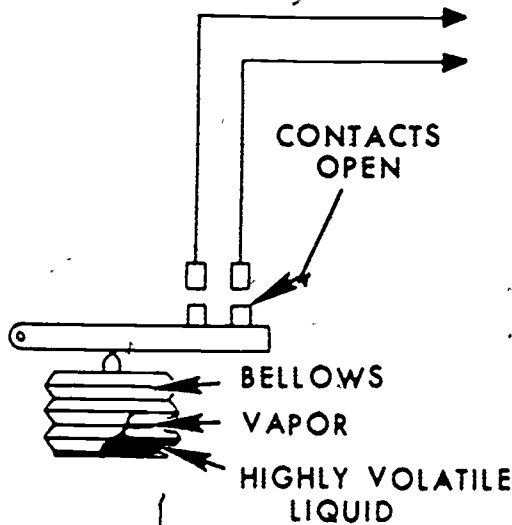


Figure 2-9. A simple bellows.

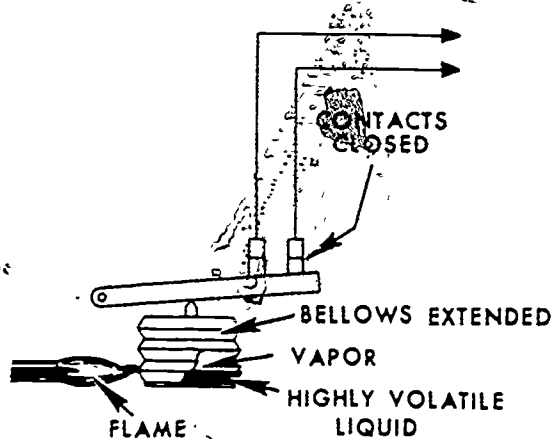


Figure 2-10. Operation of a vapor-tension device.

well. The instrument is detachable from the well, and can be removed and replaced whenever necessary without draining the system.

Exercises (211):

1. In what location should you install or replace a thermostat?
2. Which control would you install or replace in a hot water system if the water temperature becomes excessively hot?
3. What do most automatic controls respond to?
4. Define a primary control.
5. What item of equipment is necessary when replacing an aquastat?

212. Name the safety controls.

There are many controls that are classified

as safety controls in the heating fields. Among the most common are the following:

Limit Controls. Limit controls, to shut down the heating equipment when the heating medium temperature becomes excessive, are essential elements of the temperature control system. In electrical systems, the limit control is an electric switch which normally is installed in series with the thermostat, a hand switch, and the holding coil of the magnetic starter (primary control—the main circuit switch). When either the thermostat, the hand switch, or the limit control breaks the circuit, the flow of current through the holding coil is interrupted and the magnetic starter opens. The following are two examples of how the limit control works.

EXAMPLE: The temperature of the electric unit heater becomes excessive. The increased heat actuates a safety thermal trip (the limit control) which interrupts the electric power supply until the outlet air reaches the proper temperature.

EXAMPLE: The thermostat is exposed to a blast of cold air (from an open door or window, for example) and sends a signal which starts the firing equipment. If exposure to the blast is prolonged, the boiler may operate so long that it becomes overheated and serious damage could occur. To prevent this, the limit control operates a safety switch which shuts down the boiler, regardless of thermostat action, when the water reaches a preset temperature. Aquastats were covered in learning objective 211. Remember that an aquastat is nothing more than a limit control for hot water.

Combustion Safeguards. Combustion safeguards shut off the firing equipment if the

flame is prematurely extinguished. There are several types, among them the following:

Stack switch. The stack switch is the simplest combustion control. It consists of a helicoidal, bimetallic element inserted in the smoke pipe or breeching. The hot flue gas causes the helix to rotate a small shaft, which closes and maintains a switch circuit. The helix opens the switch and shuts off the burner when any appreciable drop in gas temperature occurs. The stack switch is well-suited to small boilers, but is slow-acting in large ones. The speed at which a stack switch reacts depends on the length of travel and velocity of the stack gases.

Protectostat. This is a fast-acting, flame-failure control. It consists of a cast iron housing containing a diaphragm; it is black coated for maximum heat absorption. The protectostat is located on the boiler front so that it "looks" at the fire. When the fuel oil is ignited, the diaphragm expands promptly and closes its switch contacts; when the flame is extinguished, the diaphragm contracts very rapidly and breaks the circuit. This control is suitable for a fixed-size flame with intermittent operation.

Photoelectric eyes. There are several types of photoelectric eyes. These controls act instantaneously to make a circuit when the oil is ignited, or to break a circuit when the flame fails. The electric eye is sighted at the flame and responds rapidly when the flame fails.

Low-Water Cut-Offs. A low-water cut-off is a switch, which breaks an electrical circuit to stop operation of the firing equipment when the boiler water drops to a predetermined level. The type and capacity of the installation served determine whether the switch is installed in series with the thermostat signal circuit, or connected directly to the main electrical power supply. In the usual design, a float mechanism which responds to boiler water level actuates the low-water cut-off.

Exercises (212):

1. Name the safety controls.
2. Why are the safety controls used on a hot water system?
3. What type of safety control would be installed in a furnace stack?

213. Specify the requirements for inspecting,

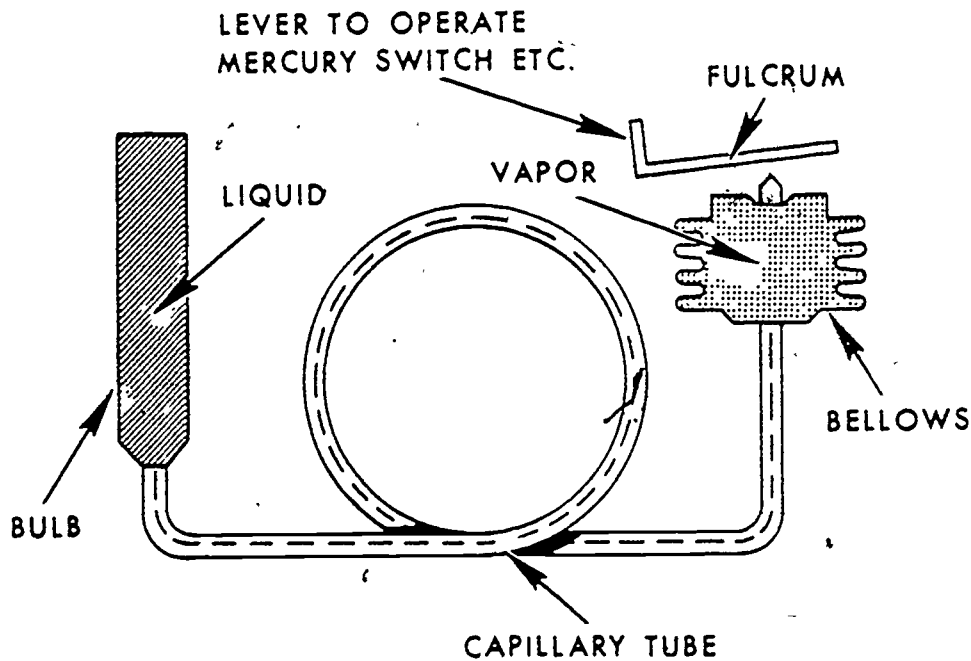


Figure 2-11 A remote bulb device.

adjusting, or replacing high- and low-pressure electrical controllers.

Pressure controls are designed primarily for steam-heating systems, but are also available for controlling air, liquids, or gases that are not chemically injurious to the control. The purpose of the pressure control is to control the pressure in the boiler, to secure the fuel-burning equipment when the pressure reaches a predetermined cutout, and to start the fuel-burning equipment when the pressure drops to the cut-in point. There are two settings on the pressure control: the cut-in point and the differential. To find the cutout point, you add the differential to the cut-in pressure. For example, if you were operating a boiler with a cut-in pressure of 90 pounds and a differential of 13 pounds, the cutout pressure should be 103 pounds. When excessive vibrations are encountered, you should mount the pressure control remotely from the boiler on a solid mounting with a suitable piping connection between them. The piping must be properly pitched to drain all condensation back into the boiler. A siphon must be connected between the pressure control and the boiler.

When a mercury-type switch control is used, be sure that it is mounted level and that the pigtail siphon has the loop extending in the direction of the back of the control and at a 90° angle to the front. This prevents expansion and contraction of the siphon from affecting the level and accuracy of the control. The pressure control can be mounted either on a tee along with the pressure gage on the pressure-gage tapping, as shown in figure 2-12, or it can be mounted on the low-water cutout provided by some manufacturers. In either case, be sure that the pipe dope is not permitted to enter the control. Apply the dope to the male threads, leaving the first two threads bare.

After the pressure control has been installed, wired, and set, it should be tested by raising and lowering the pressure on the boiler to make sure that it operates the controlled devices properly. If the cut-in and cut out points do not agree with the pressure gage on the boiler, the scale plate on the controller may be moved slightly up or down until it does agree with the pressure gage. If it is not functioning yet at the proper pressures, you may have to adjust the pressure setting indicator.

Exercises (213):

1. What are two settings on the pressure control?

- 96
2. How is the pressure control tested after it has been installed, wired, and set?

3. When using a mercury-type switch, what prevents expansion and contraction from affecting the control accuracy?

4. In replacing a pressure control, what requirement is necessary to prevent contamination to the control?

214. Cite the different types of thermostats and switches.

It is important to remember that all controls are switches. For example, a room thermostat for heating makes contact on a temperature fall, causing a burner to start. This warms the area and causes the thermostat to break contact and stop the burner. These devices in heating control equipment operate electrical circuits in response to signals from automatic-control units. In other words, the actions initiated by temperature, pressure, and humidity devices change, open, or close switch contacts. These in turn control the operation of the heating plant through electrical circuits. The most common switches with which you will be working may be either the snap-action type or the mercury type.

Exercises (214):

1. What types of switches and thermostats are most common to the heating specialist?
2. What causes switch contacts to change, open or close?
3. Which switch sends a signal to the primary control?

215. Tell how to check for a needed periodic

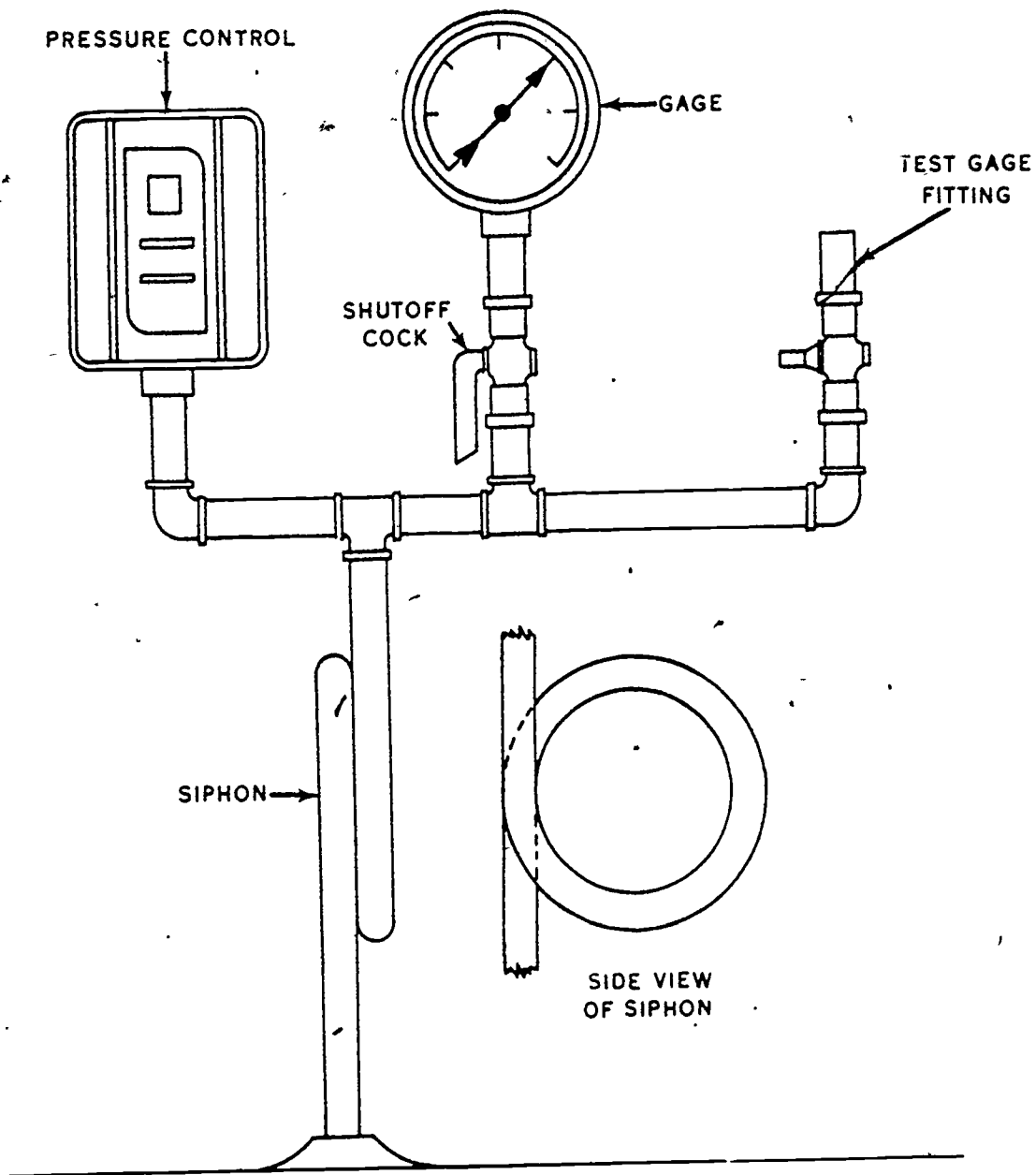


Figure 2-12. Pressure control installation.

adjustment of electrical thermostats and pressure controls.

Temperature and Pressure Controls. Proper use of these delicate instruments requires that you remember these instructions for maintenance:

a. Only authorized and trained personnel should repair, calibrate, or adjust temperature and pressure controls.

b. When steam flow is controlled by these controls, slowly warm up the line and drain the condensate before operating the regulating valve.

c. Blow down strainers and clean the baskets at regular intervals.

d. Daily, observe operation of the controls for proper functioning.

e. Check for leaks; stop stuffing box leaks as soon as possible.

Monthly Inspection. Monthly, you must:
a. Check thermostats for proper temperature settings. Make sure that the thermostat cover is in position and secure. See that the thermostat is not used as a hatrack, and that no obstruction interferes with the proper circulation of air through the sensing

element. Observe the number of open windows. If the set temperature is too high, lower the thermostat setting. Opening the windows to lower room temperatures wastes fuel.

b. Check the operation of mechanical-type limit controls by manually actuating the operating lever. Check the linkage to the draft and check-dampers. See that draft and check-dampers operate freely. Check the position of the lever arm and weight setting for the desired temperature limits.

c. For electric-type limit controls, check the setting of the aquastat for proper cut-on and cut-off temperatures. Set the thermostat above room temperature, then check the

operation by changing the setting and observing how the controlled equipment functions. When the test is finished, reestablish normal setting of the thermostat and limit control.

d. Check the operation of all electrical switches and relays. Observe any abnormal temperatures. Examine fuses for evidence of tampering. Do not shunt fuses nor use fuse elements of a larger rating than required for circuit protection.

Annual Inspection. Repeat the monthly inspection of thermostats. Check the calibration by hanging an accurate test thermometer within 2 inches of the thermostat. Allow 15 to 30 minutes for

NUMBER	SIZE		WEIGHT (FEET PER POUND)	CURRENT-CARRYING CAPACITY (AMPERES)			RESISTANCE (OHMS PER 1,000 FEET)
	NATURAL SIZE	DIAMETER (INCHES)		RUBBER-INSULATED WIRE IN CONDUIT OR CABLE	RUBBER-INSULATED WIRE ON INSULATORS	WEATHER-PROOF WIRE ON INSULATORS	
40	TOO SMALL TO SHOW ACCURATELY	.0031	33,410.	—	—	—	—
36		.0050	13,210.	—	—	—	—
30		.0102	3,287.	—	—	—	—
24		.0201	817.6	—	—	—	—
18		.0403	203.4	—	—	—	—
16		.0508	127.9	—	—	—	—
14		.0640	80.44	15	24	30	2.48
12		.0808	50.59	20	31	39	1.56
10	.1018	31.82	25	42	54	0.98	
8	.1284	20.01	35	58	71	0.62	
6	.184	12.58	50	78	98	0.39	
4	.232	7.91	70	105	130	0.24	
2	.292	4.97	90	142	176	0.15	
1	.332	3.94	100	164	203	0.12	
1/0	.373	3.13	125	193	237	0.10	
2/0	.419	2.48	150	223	274	0.08	
3/0	.470	1.97	175	259	318	0.06	
4/0	.528	1.56	225	298	368	0.05	
350 MCM	.681	0.925	300	421	508	0.03	

SIZES 40 TO 8 ARE SOLID WIRES. SIZES 6 TO 2 ARE 7-STRAND CABLES. SIZES 1 TO 4/0 ARE 19-STRAND CABLES. SIZE 350 MCM IS A 37-STRAND CABLE.

MCM IS THE DESIGNATION OF WIRE SIZE IN THOUSANDS OF CIRCULAR MILS. 350 MCM = 350,000 CIRCULAR MILS.

Figure 2-13. Various sizes of wire.

thermostat and thermometer to adjust themselves to room temperature. The thermostat contacts should close when the control knob or dial is set for the temperature indicated by the test thermometer. Recalibration is unnecessary when the closing point varies 1° F. or less. If recalibration is necessary, use the manufacturer's instructions. Clean the contact points with a good grade of writing paper or with a calling card; never use metal or abrasives.

Exercises (215):

1. You are checking thermostats with a test thermometer, when would recalibration be necessary?
2. In cleaning contacts on electrical switches, you would use what type of equipment?
3. After an adjustment is deemed necessary, who has the responsibility to adjust a steam boiler pressure control?
4. What is one method of checking to see if an aquastat needs adjusting?

216. Identify the types of wire used in heating units.

Wiring systems used in heating units may be composed of various types and sizes of wires. The insulation on the wire itself generally determines the wire type. Most electrical wire is made of copper or at least a copper alloy. In recent years, however, aluminum wire has sometimes been used. Wire and cables are manufactured with various types of insulation. This is necessary because certain types of wiring are required for specific locations. The terms "wire" and "conductor" are used interchangeably.

Terminology and Wire Sizes. The terms and definitions listed below should become everyday language in your work. Become acquainted with each term and its meaning.

- Wire—Thin rod of hard or soft drawn metal.
- Conductor—Wire, either bare or insulated.

- Stranded conductor—Conductor made up of a group of wires.
- Strand—One wire of a stranded conductor.
- Cable—Stranded, insulated conductor made up of a combination of conductors insulated from each other.
- Cord—Small flexible cable.
- Duplex cable—Two insulated conductors twisted together with or without a common sheath.
- Twin wire—Two small, insulated, parallel wires having a common covering.
- Single conductor—One solid or stranded, insulated wire.
- Two-conductor—Two solid or stranded, insulated wires enclosed in one rubber, armor, or thermoplastic cover.
- Three-conductor—Three solid or stranded, insulated wires enclosed in rubber, armor, or thermoplastic cover.

Wire sizes are indicated by number. The larger the number, the smaller the wire. The size of solid wire is based on the wire's diameter. The size of stranded wire is based on the cross-sectional area of each individual strand. Wire ranges in American Strand Wire Gage (AWG) sizes from No. 40, the smallest, to No. 4/0, the largest. The even-numbered sizes are most commonly used.

Figure 2-13 shows you the various sizes of wire. Both the AWG number and equivalent diameter in inches are shown. Notice also the current-carrying capacity of each size. Sizes 40 through 8 are solid wires. You seldom use wire smaller than No. 14 for interior wiring systems. However, sizes 18 and 16 are sometimes used in wiring appliances, fixtures, and signal and alarm circuits. Sizes 40 to 20 are most commonly used in motor and electromagnet windings.

In large size wires, No. 6 and larger, a solid wire would be too stiff to handle. Therefore, a number of smaller wires are twisted together to form a stranded wire. A stranded wire has the same cross-sectional area as a single solid wire of the same size. Large stranded wires are generally referred to as cables. Cable sizes No. 6 to No. 2 are 7-strand cables; sizes No. 1 to 4/0 are 19-strand cables. Cables larger than No. 4/0 are 37-strand cables, and their size is designated by MCM (thousand circular mils). A circular mil is the area of a circle one-thousandth of an inch in diameter. For example, the 350 MCM cable shown in figure 2-13 contains a cross-sectional area of 350,000 circular mils. Cables are manufactured in MCM sizes ranging from 250 MCM to 2000 MCM. You must remember

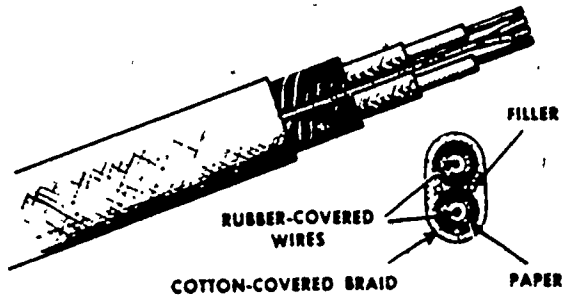


Figure 2-14. Nonmetallic type cable.

that the size of wire and cable is determined by the diameter or the cross-sectional area. This does not include the insulation of the wire or cable.

Insulation. You previously learned that the insulation on wire determines the wire type. Different insulating material is necessary when installing wire and cable in specific locations. For example, you do not install a common rubber-insulated wire in a location where it is subjected to high temperatures. Neither do you install an asbestos-insulated wire or cable where it is subjected to moisture. The locations where various types of wire may be used are covered in the National Electrical Code Book. The Code also requires the manufacturers of wire and cable to properly identify their product. Manufacturers must indicate the size and type of wire, the insulation voltage rating, the trade name of the wire, and the date the wire was manufactured. This information is printed directly on the outer surface of the insulation. You can learn much about wire and cable by just reading the markings on the insulation. Wire types are designated by letters which indicate the type of insulation on the wire. For example, "RH" stamped on wire insulation means the insulation is rubber and is heat resistant. Some of the more common types of wire are listed below. Notice that the letter designations indicate the type of insulation. The location where each type may be used is also listed.

- RF—Rubber-covered fixture wire. Used for fixture wiring only.
- R—Rubber. Used in dry locations.
- RH—Rubber, heat resistant. Used in dry locations.
- RW—Rubber, moisture resistant. Used in dry and wet locations.
- RHW—Rubber, heat and moisture resistant. Used in dry and wet locations.
- T—Thermoplastic. Used in dry locations.
- TW—Thermoplastic, moisture resistant. Used in dry and wet locations.

- THW—Thermoplastic, heat and moisture resistant. Used in dry and wet locations.
- A—Asbestos. Used in dry locations for wiring appliances.

Duplex Wire. Residential and office buildings are sometimes wired with duplex wire. Duplex wiring is popular because it is easy to install and is relatively inexpensive. Also, when installed properly, duplex wiring is as safe as the more expensive types.

There are various types of duplex wire. However, they all consist of two insulated wires enclosed in a protective sheath or covering. Duplex wire is commonly referred to as cable. Most of these cables consist of type R (rubber-insulated) or type T (thermoplastic-insulated) wires which are enclosed in a plastic or a fabric sheath. The sheath holds the wires together and protects the individual wires. In addition to the outer sheath, paper is sometimes wrapped around the individual wires. This provides added insulation and protection. A cable with two No. 14 wires is called 14-2 cable; a cable with two No. 12 wires is called 12-2 cable. One of the wires in the cable is colored black, while the other is colored white. Duplex wire is also available with a third bare wire, which is used as a ground. This type of cable is used where circuit components require grounding.

Duplex wire is known as nonmetallic sheathed cable, armored cable, and lead-sheathed cable. When the wires are enclosed in a fabric or plastic sheath, the cable is called nonmetallic sheathed cable. Figure 2-14 shows this type cable. Notice that the individual wires are rubber insulated and are wrapped with paper. The outer sheath is a fabric material.

When duplex wire is enclosed in a flexible metal covering, the cable is called armored cable. Armored cable provides more protection for the wires than does nonmetallic sheathed cable. Figure 2-15 shows you another type of duplex wire, the lead-sheathed cable. The lead sheath gives

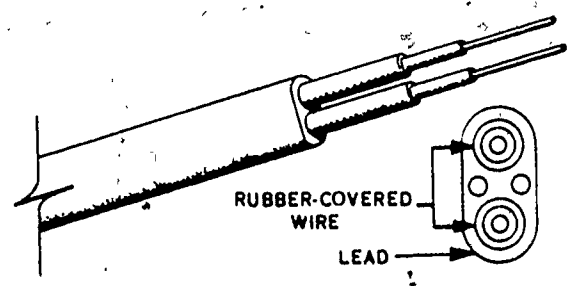
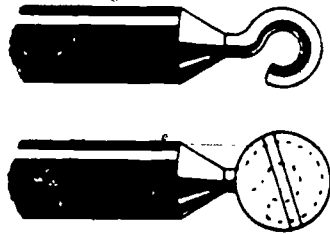


Figure 2-15. Lead-sheathed duplex cable.



CEU-032

Figure 2-16. Loop connection.

protection against moisture and insulation-destroying gases and liquids. This type of cable may be buried directly in the ground and used in wet locations.

Exercises (216):

1. Distinguish between a conductor and a cable.
2. Explain what kind of wire you would be using if your supervisor gave you a roll of AWG, 14-3 RW.
3. A safe inexpensive wire is known as duplex wire. What is it?
4. What determines the wire type?
5. What would you be wiring if you were using AWG 16A wire?

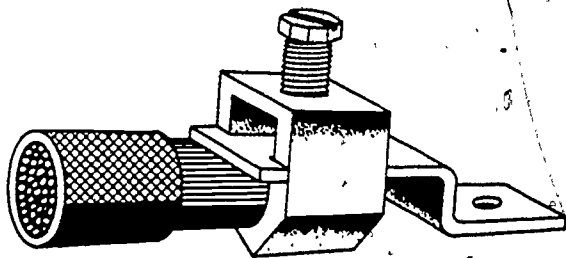


Figure 2-17. Mechanical connector.

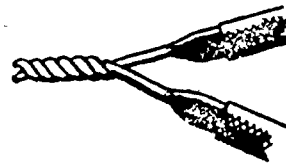


Figure 2-18. A pigtail splice.

217. Explain how some connections are made in replacing wires.

To install or replace wiring and cables, it is necessary for you to make various types of connections and splices. Normally, screw terminals or connectors of some sort are provided for connecting wires to switches, receptables, controls, and so on. However, for connecting wires together in junction boxes and outlet boxes, you make various kinds of splices. Splices are made by twisting the ends of two or more wires together. Splices may also be made by using various mechanical devices to hold wire ends together.

Before a wire or cable can be attached to a device or be spliced, the insulation must be removed at the point of connection. Just enough insulation is removed to make the connection, no more. As you gain experience, the removal of the proper amount of insulation for each connection and splice will become automatic. The electrician's knife is most generally used to remove insulation. However for small size wire, a wire-stripping tool may be used. When you remove insulation with a knife, be careful that you do not cut into the wire itself. A nick may cause the wire to break after it is installed. A deep nick or scratch reduces the current-carrying capacity of the wire. After the insulation is removed, burnish (scrape) the wire end with your knife or fine sandpaper. This removes any bits of insulation and oxidation remaining on the wire.

For connecting wire to screw terminals, use your longnose pliers to form a loop or eye in the bare end of the wire. Such a loop is shown

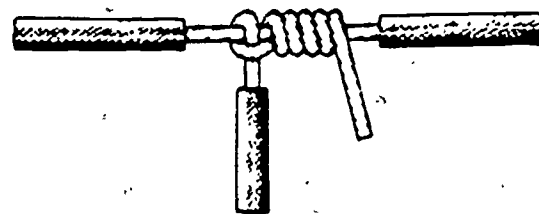


Figure 2-19. A tap splice.

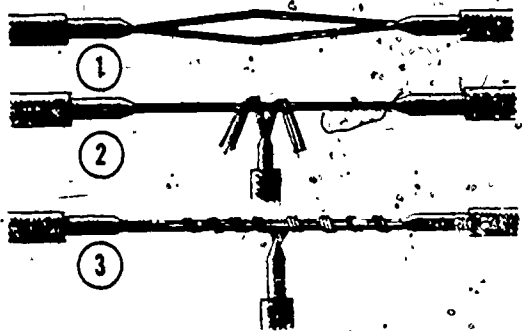


Figure 2-20. Stranded wire, tap splice.

in figure 2-16. Notice how the loop is placed around the screw. As the screw is tightened, it tends to close the loop. If the wire is not placed on the screw in this manner, the loop tends to open when the screw is tightened. When you make this type of connection, the insulation must cover the wire close to the terminal screw. When too much insulation is removed, the bare wire is exposed for too great a distance from the screw. Notice in figure 2-16 how the insulation is removed to form a "cone" at the end. When you remove insulation with a knife, always leave the end cone-shaped. When a wire stripper is used to remove insulation, the end is left at a right angle to the wire.

Where large wire (generally No. 6 or larger) must be connected to switches or other devices, a mechanical connector is provided. Figure 2-17 shows one type of mechanical connector (sometimes called solderless connector). To use this type of connector, you simply place the bare end of the wire in the connector and tighten the screw. As with the loop connection for smaller wire, the insulation must extend up close to the connector.

Wire splices must be mechanically and electrically secure. That is; the splice must be as strong as a continuous wire, and it must conduct electricity as easily as a continuous wire. When you join two or more small wires together in a junction or outlet box, use the pigtail splice. Figure 2-18 shows two wires joined together by a pigtail splice. To make this splice, you remove the insulation from the wire ends, clean them, and then twist the ends together. Use pliers for twisting the ends together. This insures that the ends are twisted tightly together. After the wires are twisted, clip off the free ends. You are now ready to solder the splice and apply insulating tape. Instead of soldering the splice, insulated

solderless connectors (wire nuts) may be used. The wire nut screws on the splice and holds it firmly. It also provides the required insulation for the splice.

You sometimes find it necessary to connect one wire to another continuous wire. This may be done with a tap splice. Tap splices may be used with solid or stranded wire, or a combination of both. To make the tap splice with solid wire, remove about 1/2 inch of insulation from the continuous wire and about 3 inches of insulation from the tap wire. Lay the bare end of the tap wire over the continuous wire. Make one wrap around the continuous wire with the free end of the tap wire. Bring the free end of the tap wire across the standing part of the tap wire, as shown in figure 2-19. With the remainder of the free end, make five close turns around the continuous wire. Cut off the excess free end of the tap wire. You are now ready to solder and tape the splice.

To tap stranded wires, separate the strands of the continuous wire and thread the tap wire through the separated strands. Separate the tap wire strands and wrap them in opposite directions around the continuous wire, as shown in figure 2-20. After the splice is made, you then solder and tape the splice. You must remember that the insulation must be restored. You do this by wrapping tape around all splices you make in insulated wire. Enough tape must be applied so that the insulating quality is equal to the insulation that you removed. The pigtail and tap splices must never be subjected to strain or tension, as in an open or overhead wiring, where different splicing methods are used. A Western Union splice, or mechanical devices (split-bolts, compression, or twist sleeves) must be used.

Exercises (217):

1. What is the meaning of a "tap" splice?
2. How do you make a "tap" splice?

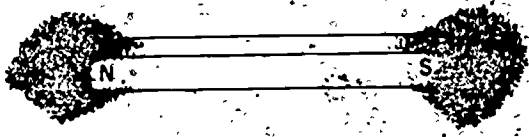


Figure 2-21. Concentration of magnetic field.

3. What type of connection do you make when you are wiring up a safety control?

4. What procedure do you accomplish after the splice has been made?

5. How much insulation is removed from wire?

218. Explain the term "magnetic field" and define molecular theory of magnetism.

The theory of magnetism is based upon a knowledge of natural magnets, which the ancients called lodestones. Modern man found that magnets could be made from iron and from metal alloys which contained iron. These are the magnets with which we are familiar, and we believe we know why they produce such important results.

Magnetic Field. When iron filings are sprinkled over the entire area of a magnet,

103
you notice that those filings which fall near the ends of the magnet are attracted to form bunches, or tufts, as shown in figure 2-21. Very few of the filings that fall near the center are so attracted. This experiment indicates that the bar magnet has two distinct regions, or poles, indicating the areas where the magnetic force is greatest.

The presence of a magnetic field surrounding a magnet can be demonstrated by sprinkling fine iron filings onto a sheet of paper or piece of glass held over a magnet. If the paper or glass is tapped gently, the filings will arrange themselves into a pattern of lines or loops, as shown in figure 2-22. This arrangement of the filings indicates the presence of a magnetic field, or flux. It is generally considered that these lines of force leave the magnet at the north pole and reenter the bar at the south pole.

The explanation of why this pattern always forms is quite simple. The iron filings become magnetized by magnetic induction when they are brought into contact with a magnetic field. This causes them to line up with the field and to concentrate at the poles where the field is strongest.

Magnetic and Nonmagnetic Substances. Iron and steel are affected by the magnetic

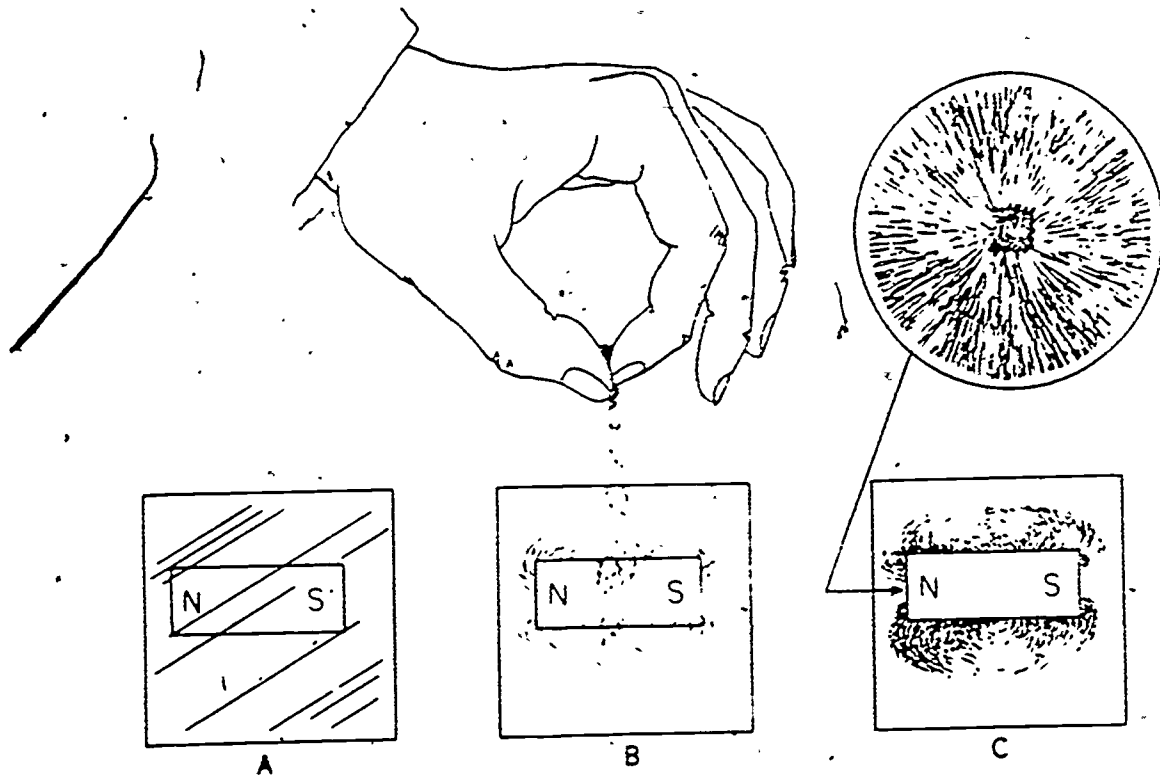


Figure 2-22. Pattern of magnetic field.

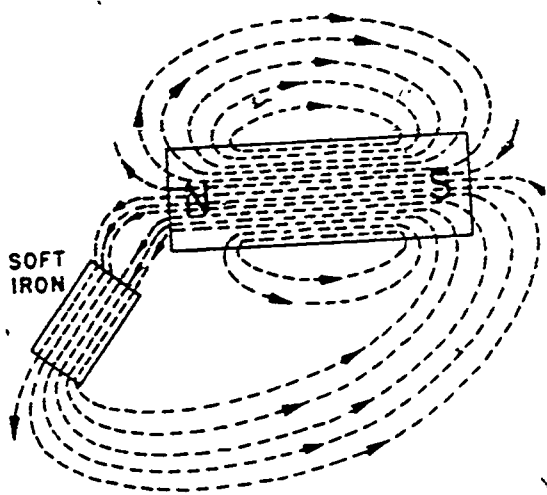


Figure 2-23. Distortion of a magnetic field.

force which exists in the space surrounding a magnet. There are other magnetic substances that are affected by a magnet in varying degrees. The more common of these are cobalt, nickel, and manganese. Most other substances are not affected and are defined as nonmagnetic. The ease with which magnetic flux concentrates within a substance is known as permeability. The indifference of a material to the concentration of a magnetic field is known as reluctance, or the opposite of permeability. Figure 2-23 shows what

happens when you place a piece of soft iron in the field of a permanent magnet. The field is distorted because of the difference in permeability of air and iron. Iron has a much greater permeability than air.

Attraction and Repulsion of Magnetic Poles. A properly suspended permanent magnet always aligns itself with the earth's magnetic field, with the north-seeking pole pointing toward the magnetic north pole of the earth. Now, if the north pole of a second bar magnet is brought close to the north pole of the suspended magnet, the suspended magnet is pushed away, as shown in figure 2-24. Reverse the second magnet and bring the south pole close to the north pole of the suspended magnet, as illustrated in figure 2-24, and the two poles are pulled together. This illustrates a fundamental law of magnetism. Like poles repel and unlike poles attract. You can see that the behavior of magnetic poles is similar to that of electrical charges, where like charges repel and unlike charges attract.

Theory of Magnetism. Like the theory of electron movement, the theory of magnetism is still only a basic assumption. Since magnets are made from substances of high permeability, a special quality must be present in the molecules of these substances. Molecules may be considered as very small magnets, each of which has two poles. The theory that a magnetic substance is composed

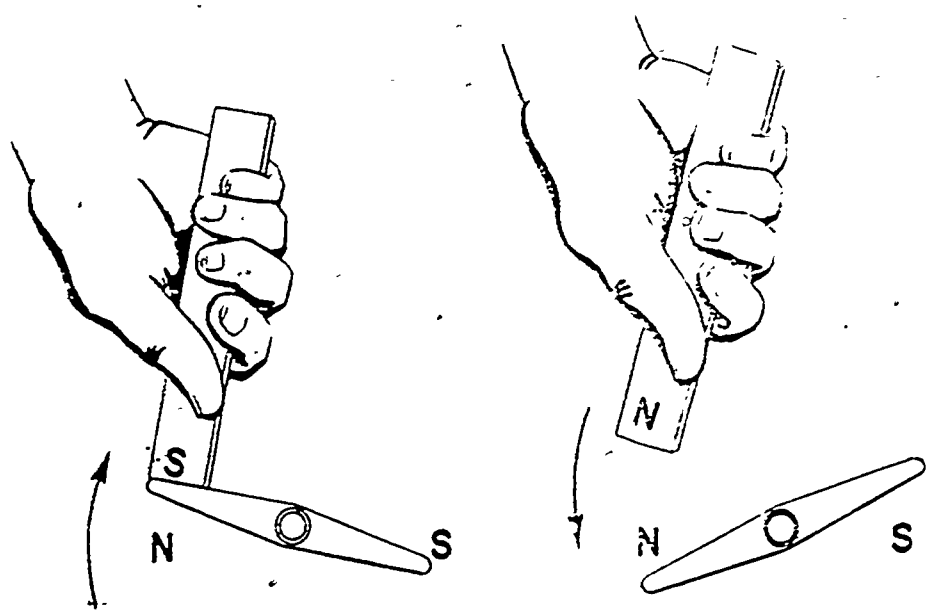
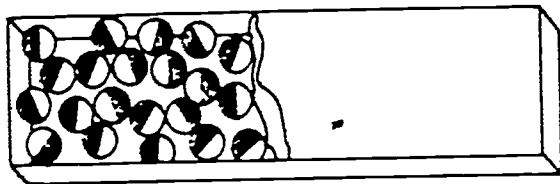


Figure 2-24. Attraction and repulsion between magnets.




MOLECULE
NORTH POLE  SOUTH POLE

Figure 2-25 Magnetized iron bar.

of millions of these tiny magnets is called the "molecular theory of magnetism." These tiny magnets may be thought of as being arranged in a haphazard manner (fig. 2-25) in an unmagnetized piece of iron, so as to cancel out the total magnetic effect. However, when the iron bar is placed in a magnetic field, the molecules become rearranged, with the north poles facing the same way.

This theory makes it possible to explain many facts. For example, hard steel requires a stronger magnetic field to produce a given degree of magnetism than does soft iron, because the molecules of hard steel are more difficult to turn. However, when the magnetizing force is removed, the molecular magnets in steel retain their position, while those of soft iron quickly return to their original haphazard positions.

Permanent and Temporary Magnets. Magnets made from soft iron are called temporary magnets, because they do not retain their magnetic qualities. Magnets which retain their magnetic qualities are called permanent magnets and are generally constructed of steel or a special alloy. Electromagnets possess magnetic qualities only when an electric current is present in the windings.

Exercises (218):

1. What is a magnetic field?
2. Define "molecular theory of magnetism."
3. What is a temporary magnet?

219. Define an electromagnet and indicate how its strength is determined.

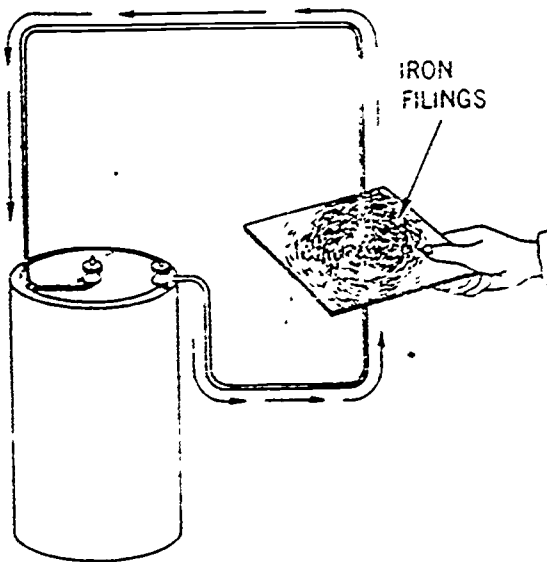


Figure 2-26 Magnetic field around a wire.

Electromagnetism. An iron bar can be made into a magnet by placing it in a coil of wire and attaching the wire to the terminals of a battery. Since it is necessary to have an electric current in the coil of wire to magnetize the iron, there must be a close relationship between electric current and magnetism. We can show this relationship with a few simple experiments.

If we attach a wire to a battery and dip a loop of the wire into some iron filings, the filings will cling to the wire as long as there is current in the conductor. Make a slit in a square piece of cardboard and insert the loop as shown in figure 2-26. If we sprinkle iron filings on the cardboard, the filings will arrange themselves in circular patterns, showing the existence of a magnetic field around the wire when there is current in the circuit.

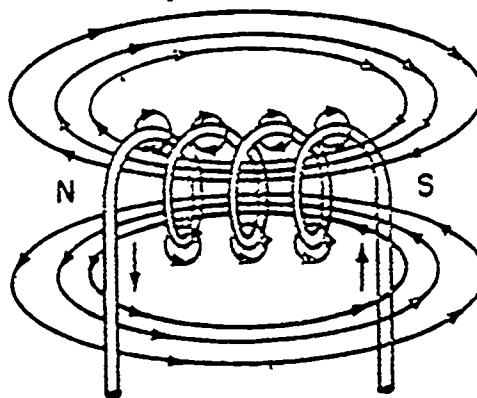


Figure 2-27. Current flow through coil.

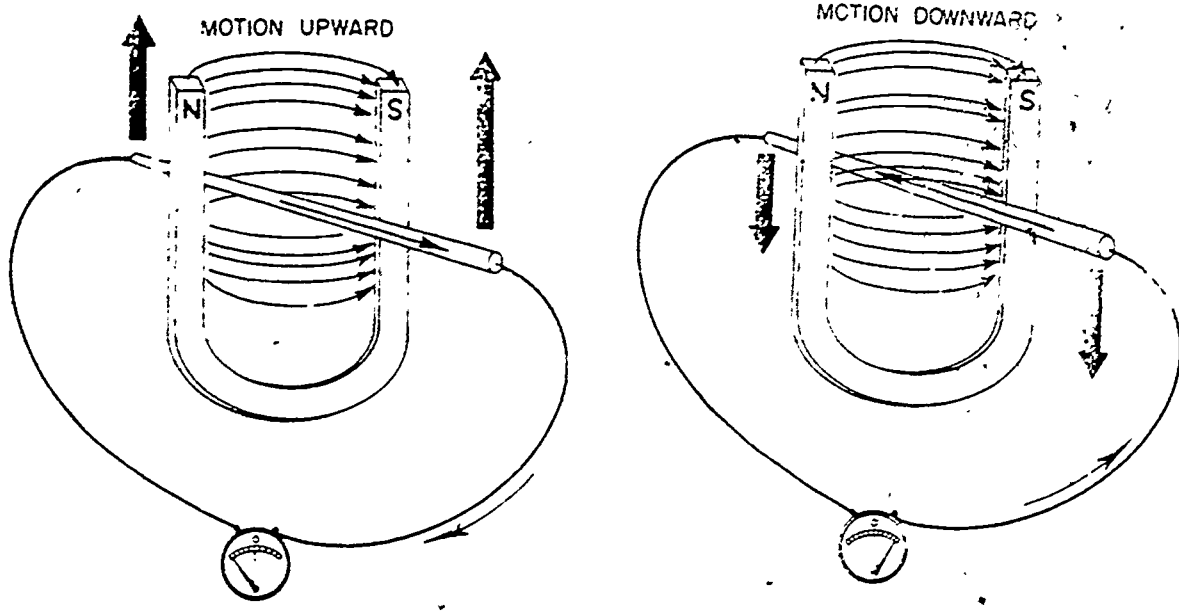


Figure 2-28. Producing current by electromagnetic induction.

Electromagnets. The field around a single conductor is not very strong; but when the conductor is formed into a coil, as shown in figure 2-27, we are able to concentrate the magnetic lines of force. Further concentration can be achieved by placing a core of soft iron in the open coil, or solenoid. The coil of wire, or solenoid, containing an iron core is actually a simple electromagnet. The strength is determined by three factors—the amount of current in the winding, the number of turns in the coil, and the material of which the core is made.

The direction of current flow through the coil of an electromagnet determines the poles of the magnetic field. This relationship is determined by the left-hand rule which states, "If the coil is grasped in the palm of the left hand with the fingers pointing in the direction of current flow, then the thumb points toward the north pole of the coil." The current flow through the coil in figure 2-27 is indicated by two arrows.

Electromagnetic induction. We have discussed the fact that electric current flowing through a conductor creates a magnetic field around that conductor. The reverse is also true in that a magnetic field can cause a current flow in a conductor. We can demonstrate this through the use of a strong horseshoe magnet, a length of copper wire, and a very sensitive current-reading meter (galvanometer), connected as shown in figure 2-28. When the conductor is moved downward through the magnetic field, the galvanometer needle is deflected, indicating

that there is a current in the circuit. When the conductor is moved upward through the field, the needle is again deflected, but this time in the opposite direction, indicating that electron flow in the wire is now reversed. We can achieve the same effect by holding the wire still and moving the magnet up and down. When there is no relative motion between the conductor and the magnetic field, there is no current flow in the wire.

When the conductor is moved across the magnetic field, some of the magnetic energy is transferred to the conductor as voltage, or emf, forcing the free electrons to move at right angles to the magnetic field. This causes

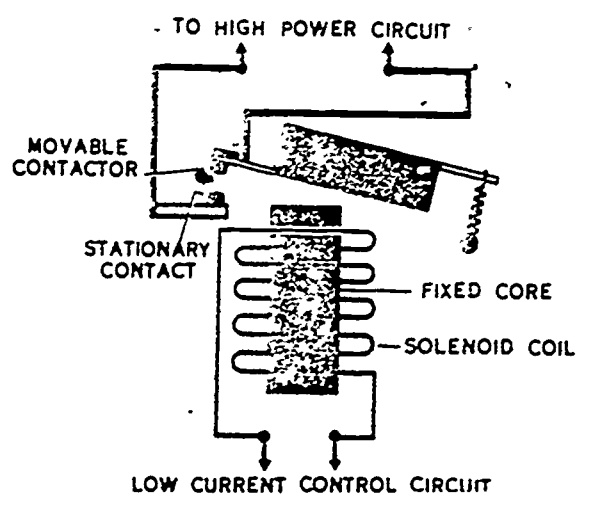


Figure 2-29. Common relay

current flow in the circuit. The amount of current produced by moving the single conductor through the magnetic field is very small. We can, however, increase the amount of current produced by increasing the speed of relative movement, forming the conductor into a coil so that more wires are cutting across the magnetic field, and increasing the strength of the magnetic field. A combination of these three methods is used to create a practical electrical generator.

Exercises (219):

1. What is an electromagnet?
2. How is the strength of an electromagnet determined?

220. Explain the function of the electromagnetic device called a relay.

Although the greatest concentration of flux in a current-carrying coil is through the center of the coil, the magnetic strength of the coil is comparatively weak. If a soft iron core is placed in the coil, however, the magnetic strength is enormously increased. The soft iron core has less reluctance than air, and as a result the concentration of lines of force is increased through the iron. Such a device is called an electromagnet. Large electromagnets are used for loading and unloading steel, pig iron, etc. Small electromagnets are used in

electrical measuring devices, door bells, buzzers, and the like.

One of the most common types of electromagnetic devices used in controls is a relay. A relay is nothing more than a switching device. It can be controlled manually by electricity from distant locations, or automatically by the circuit.

Almost all of the more common relays contain a length of insulated wire wrapped around an iron core, as you see in figure 2-29. When current is passed through the relay coil, a magnetic field builds up around the coil to make the iron core an electromagnet. The switch end of the relay is made up of a piece of soft iron attached to some nonconducting material. This is hinged at one end of the relay frame and extends over the top of the relay coil. The instant current flows through the relay coil, the iron core pulls down on the free end of this armature, while the other end swivels on its hinge. At the free end of the armature we find one or more contact points which are made of copper, silver, or platinum.

The idea behind the relay is to create a switch by connecting one part of a circuit (or circuits) to these swinging contact points, then continue the circuit (or circuits) from one or more stationary contact points located somewhere in the downward path of the moving (armature) points. When these two sets of points come in contact with each other, the once-open circuit becomes a closed circuit. The relay remains energized until someone or something shuts off the current flowing to the coil.

As you remember from an earlier discussion, a relay is nothing more than an electromagnetic switch. One relay can be made to control many other relays. In electronic controls, we can use a master relay to make other relays automatically open or close their respective circuits when a particular event takes place.

A good example of an electromagnet is the solenoid. For all practical purposes, solenoids are nothing more than heavier duty relays. The one main construction difference is that the solenoid moves an internal iron core instead of attracting an armature to close a set of contact points. Figure 2-30 shows the two parts of a circuit attached to two fixed contact points mounted in line with each other, but separated by an airspace.

When current is passed through the coil, the magnetic field developed around the coil pulls the movable iron core down into the coil. When it comes to rest on the fixed contact points, the core's metal T-head forms

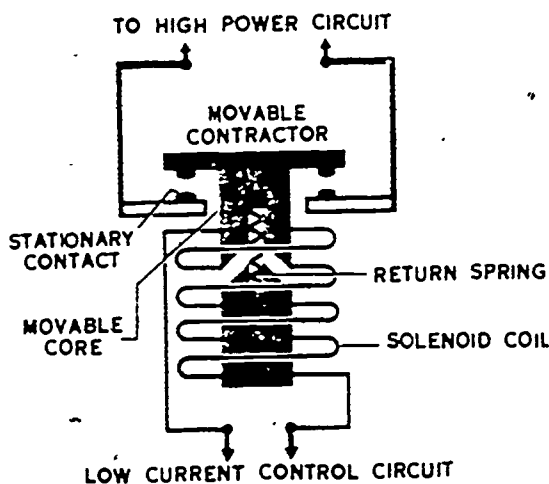


Figure 2-30. Common solenoid.

a bridge to complete the main circuit. Because of its heavy-duty construction, the solenoid can handle much higher main-circuit currents than a relay. Instead of simply closing the points, a solenoid can be used to operate a mechanism such as a valve, brake, change gear ratio, etc.

Exercises (220):

1. What is a relay?
2. What is the difference between a common relay and a solenoid?
3. What is the function of a relay?

221. Specify the parts of a relay switch and list the procedures for removing and replacing a relay.

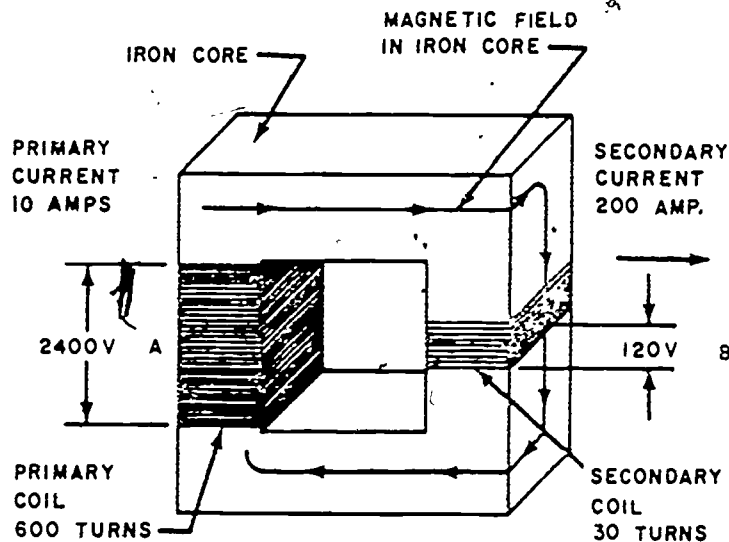
Relay switches are magnetic devices actuated by the operation of a pilot or control circuit. You will find them used to control groups of circuits simultaneously or to control heavy current-carrying circuits. Figure 2-29 shows a diagram of a relay switch.

It consists essentially of movable contacts, stationary contacts, fixed core, solenoid coil, and return spring. The movable contacts act as a switch for the circuit to be controlled. The interruption of the current through the solenoid coil causes the movable contacts to move, thereby opening or closing the controlled circuit. Relays are designed to operate from either line voltage or from a lower control voltage. They may be used to control a single circuit or many circuits simultaneously. Relays are used in various types of heating control systems such as solenoid valves and protecto-relays.

General procedures for removing and replacing relays are closely associated with the use of testing equipment and its included meters and instruments. All defective relays found should be replaced. In removing or replacing relays or electrical components, you should always secure the power and remove the relay or component. On solenoids, remove cover retaining nut, screw, or clamp ring. Next, the coil jacket assembly is removed, and then the coil and all parts in need of repair or replacement.

In replacement, make sure you have the correct parts for the specific relay solenoid or component. Use reverse procedures when reassembling and replacing relays, solenoids or electrical components.

Because of the numerous types and models of components and their applications, always consult the manufacturer's specifications.



$$\text{RATIO} = \frac{\text{TURNS IN PRIMARY}}{\text{TURNS IN SECONDARY}} = \frac{600}{30} = \frac{20}{1}$$

Figure 2-31. Principle of transformer.

when troubleshooting, repairing, or replacing any type of electrical device.

Exercises (221):

1. Identify the parts of a switching relay.
2. List the procedures for removing and replacing a relay.

222. Given a situation on testing a transformer, determine whether or not the transformer is good or bad.

In the discussion of solenoids, you found that by wrapping a coil of wire around an iron core and passing electricity through it, a magnetic field could be produced in the core. Similarly, if a magnetic field can be passed through a coil, electricity can be produced in the coil. This is the principle of a transformer. (See fig. 2-31.)

Alternating current flows through coil A, causing a magnetic field in the core. Each time the current changes direction the magnetic field collapses and builds up again. As the field collapses and builds up, the magnetic lines of force cut through coil B. An alternating current is thus produced in coil B. The coil connected to the source of electricity is the primary coil. The coil in which the electricity is induced or to which it is transferred is the secondary coil. Thus, when voltage is induced in the secondary coil in a closed circuit, current flow results. Transformers are primarily installed in electrical circuits used in the heating field to step up or step down the voltage. Step-up transformers are used in circuits of oil burners, and step-down transformers are used in connection with low-voltage controls.

If a transformer has become inoperative, you should make a visual inspection of the electrical connections to insure that the transformer still has power. Don't waste time with weak or defective transformers. A poor unit can only be troublesome and time-consuming in its operation. There are many commercial-type transformer testers, but you will need to know the steps to field test a transformer unit.

The first step in field testing is to disconnect the motor terminal leads at the relay or the motor lead wires in the oil burner junction box. In carrying out this operation, no oil should be permitted to flow during the

test. Open up the back, or access plate, of the oil burner so that the high tension terminals are exposed to working view. Turn the unit on during the test. Turn it off immediately following the completion of the test.

Using an insulated handle screwdriver, touch the high tension terminals with one end of the screwdriver while shorting out the upper end of the tool against the burner frame or housing. Slowly draw the upper part of the tool away from the frame, continuing to hold the point of the screwdriver on the high tension terminals. Note the length of spark which can be drawn out during this process. An unfaltering spark of at least $\frac{3}{4}$ inch constitutes a good transformer. Anything less than this is subject to immediate replacement.

Exercises (222):

1. Why shouldn't you waste time with a defective transformer?
2. In testing a transformer, you obtain an intermittent spark of 1 inch. Is the transformer good or bad? Explain.

223. List the requirements for replacing transformers.

When tests are completed and a transformer is deemed inoperative, it needs to be replaced. Insure that the replacement transformer is the same type and size. It is essential that all windings in a transformer be correctly connected. The connections will vary according to the type of transformer and the system in which the transformer is used. Transformers are connected to different burners at different places; therefore, transformers can be obtained with different mounting plates. Be sure to install the correct mounting plate when replacing a transformer. Always consult the manufacturer's instructions on the correct mounting procedures.

Exercises (223):

1. What do you make sure of when you are replacing one brand of transformer with another brand with the same windings?

49

2. You are assigned to replace a defective transformer. The old or defective transformer has been removed. What step do you take?

224. Name the requirements for removing and replacing electric motors.

An electric motor is a machine that changes electric energy into mechanical energy. Motors vary in size; normally, the larger the motor, the larger the horsepower. You, as a heating specialist, will come in contact with many types, sizes, kinds, and uses of motors. Motors designed for burners, pumps, and fans are the more common uses.

Though the original design of the motor does not fall within the scope of a heating man's job, it becomes his job to select a suitable replacement. When a motor in service is faulty, replace it. Before you start to remove it, deenergize the power source. Do this by opening and tagging the proper disconnect switch or circuit breaker, or by removing the proper fuses. Above all, be sure the motor circuit is "dead." Then tag all the lead and line wires as you disconnect the unit from the power source. This procedure insures proper installation of the leads when the motor is replaced. Before connecting a replacement motor to a power source, you should refer to the nameplate or manufacturer's manual for the proper connections for the unit. By checking these sources of information, you will prevent unnecessary damage to the unit and will connect the unit in the proper way.

There are certain items to check before you replace a motor.

- a. Voltage. The new motor should match the power source.
- b. Amperage rating. Make sure the new motor doesn't pull too many amps.
- c. Proper rotation. Select the motor with the proper rotation.
- d. Connections. The nameplate on a dual voltage motor usually gives a diagram that shows the electrical connections for each voltage.
- e. Alinement and belt adjustment. Make sure the replacement motor will align properly and the belt is not worn or frayed.
- f. Size of shaft. Check the size of the shaft so that you can use the same pulley. The wrong pulley size will change the operating speed of the equipment.
- g. Enclosure. You must consider where the

110
motor is located and whether you have the proper type of replacement.

When you are sure you have the proper motor for replacement, connect the motor to the power source. Operate it and check for unusual noises and vibrations, proper speed, and temperature rise. If you cannot hold your hand on the motor, it is too hot. Overheating can damage the windings and insulation. Compare the measured current draw against the current draw stamped on the data plate. Excess current draw indicates an overloaded motor. If you have installed new belts, recheck the belt tension after operating the motor for 24 to 48 hours.

Exercises (224):

1. Name the procedures for removing and replacing electric motors.
2. Why do you recheck new V-belts one or two days after installation?
3. Name some requirements necessary for replacing motors.

225. Cite a requirement for wiring motors to power source and indicate where the proper procedure can be found.

Learning objective 224 provided necessary information concerning wiring motors to a power source. In addition, all electrical connections to a motor should be tight enough so that the vibration of the equipment does not loosen the connections. Wires joined in a conduit box should be twisted together and soldered or bolted together. Flexible cables from a conduit box on a small, fractional horsepower motor should be held so no strain is placed on the connections themselves. Using a plug connector in a convenience outlet is an approved method of connecting a motor supplied with a flexible cable.

Exercises (225):

1. Why must connections joined in a conduit box be soldered or bolted?

2. Where do you go for the proper method to wire in a motor.

3. List a requirement for wiring a motor to the power source.

226. Specify the safety procedures followed when performing duties with or near electrical equipment.

You must frequently make inspections of electrical facilities to check for safety hazards. A circuit that contains loose connections or wires having frayed or cracked insulation presents a fire hazard as well as an electrical hazard. All wires and cables having damaged or deteriorated insulation must be replaced. Switch handles must be kept clean, dry, and in good condition. The floors in electrical control and equipment rooms must be kept clean and dry at all times. A damp or wet floor is one of the greatest hazards; you can easily get electrocuted when you work with electricity in a wet location. Where main switches and distribution panels are located in an equipment room, keep the room locked at all times. This is necessary to keep unauthorized people from tampering with the equipment. Where high-voltage signs are posted, make sure they are placed in a conspicuous place and are easy to read.

Check the grounding system on all electrical distribution systems and equipment. The grounding system is provided so that in the event of short circuits, the voltage is conducted to ground. A good grounding system insures that the circuit protective devices (fuses and circuit breakers) open when a short circuit occurs. Do not tamper with protective devices. If you remove a fuse to work on a circuit, reinstall the same fuse when you complete your work. Never install a larger (higher ampere rating) fuse than the one you removed.

Clothing and Jewelry. When you work around electrical equipment, especially rotating machinery, avoid wearing loose clothing. You can imagine what might happen if part of your clothing became wrapped around a rotating motor shaft. Clean, dry clothing is a fairly good insulating material if it is free of holes. Your pockets are an important item of safety; keep them free of metal objects. Never place screwdrivers and other sharp-pointed tools in your pockets.

111

You must not wear jewelry when working with electrical and mechanical equipment. People have lost fingers because of their reluctance to remove a certain favorite ring. Rings and watches can cause you to get a severe burn, even from low-voltage batteries. It takes only a fraction of a second for a ring or watch to become red hot when shorted between the conductors in a circuit. Be alert! Remove that jewelry before you start work.

Work on Energized Circuits. AFP 65-1 specifically states:

As a general rule, no work will be performed on energized electrical circuits or equipment. As an exception, work may be performed on energized circuits to prevent possible injury to others, or where critical missions will be jeopardized by interruption of service.

If it becomes necessary for you to work on energized circuits, work only with another fully qualified electrician. Make sure you have the necessary protective equipment—rubber gloves, rubber blankets, rubber mats, and so on. The type of work and the conditions under which you work determine the exact type of protective equipment to use. One thing you must remember: safety equipment can become defective, so inspect it before you use it. A small crack or hole may make it unsafe for use. Do your job thoroughly: your life depends upon your thoroughness.

Work on Deenergized Circuits. Deenergized circuits do not present as great a hazard as do energized circuits. Nevertheless, you must be careful and observe safety rules. Make sure the circuit is deenergized by opening the switch. In some cases, you may be able to lock the switch in the open position. Where the switch cannot be locked, remove the fuses and attach a warning sign to the switch. Keep in mind that a circuit may become accidentally shorted to another circuit. For this reason, test the circuit with a voltmeter to make sure it isn't shorted and still "hot." You cannot afford to become careless, even when working on a "dead" circuit. Never lean against water pipes or other grounded devices when you work on any electric circuit.

Exercises (226):

1. Why must equipment rooms be kept locked?
2. Why are grounding systems provided on electrical systems and equipment?

112

3. Explain the necessity for removing jewelry before working with or around electrical equipment.

4. List safety procedures performed when working on an energized circuit.

227. List the safety rules followed when performing duties with or near common and special tools and test devices, and tell where complete safety precautions covering such duties may be found.

With your work in the electrical field, you must be fully aware of the hazards involved when working with electrical equipment. In fact, the more you know about electricity, the more safely you can perform your duties. The general rules given here are for your own safety and for the protection of the men working with you. They should be carefully studied until you are familiar with them. They must be continually practiced until they become a habit which is second nature to you. Among pilots there is a term called "forgiven error," which refers to a mistake which did not result in disaster. This term can well be applied to your work in the electrical or mechanical field. When you find that you have made one of these forgiven errors, you should carefully review the events which led you to make this mistake. You will thus find the source of your mistake and be able to avoid a similar situation in the future.

Regard all electrical circuits as being live. This rule must be observed in all cases, except where you have opened the switches, made a voltage test, and know that the line is dead. In the case of long lines which are opened and grounded at some distant point, a preliminary inspection or test must always be made to determine what conditions exist. Remember that someone may accidentally open the wrong breaker, leaving your circuit connected to high voltage. Furthermore, to keep anyone from accidentally closing the breaker to a circuit which is undergoing repair, the breaker switches should be locked in the OFF position and tagged to indicate that the system is being repaired. A few general rules which must be observed in electrical work are as follows:

- Do not wear identification tags when working around electrical machinery.
- Do not wear jewelry or zipper clothing

when working around batteries or electrical equipment.

- Always use safety tools and devices wherever they are provided. This includes the following:

1. Fuse pullers for removing and replacing fuses.

2. Rubber floor mats around electrical panels.

3. Rubber aprons when working on acid-type batteries.

4. Work gloves when working around high-temperature equipment.

5. Rubber gloves when working on live electrical circuits.

- Always follow safe operating procedures. A man must never work alone on energized electrical circuits.

- Don't struggle with a toolbox or an item which is too heavy to be handled conveniently.

- Don't clutter your work area with unnecessary equipment. If you do not intend to use an item, store it in a safe place.

- Always use the right tool for the job.

- When possible, use handtools so that the working force is always directed away from your body. This will minimize the chances of injury in case the tool should slip.

- Never put your hand on an electrical conductor unless you are working on the circuit and know that the circuit is dead. Always be sure that the switches to the circuits on which you are working are locked out and tagged.

- Never try to remove a man or a tool from a live circuit with your hands or with a piece of material which may be a conductor. Insulating material such as a shirt or a piece of dry rope can be used as a loop to pull a man from a live circuit.

- If battery acid should splash on you, immediately flood the affected part by washing with water.

The above are only a few of the rules which, if followed, will help in establishing safe work procedures. There are many more safety precautions and rules which must be observed. It is recommended that you refer to Air Force safety publications to help you in learning how to work safely.

Exercises (227):

1. What is an important safety rule to remember when repairing an electrical circuit?

- 2. What precaution is taken, if possible, to prevent injury in case a tool slips?
- 3. Where would you locate complete safety precautions which should be observed when performing duties with tools and test equipment?

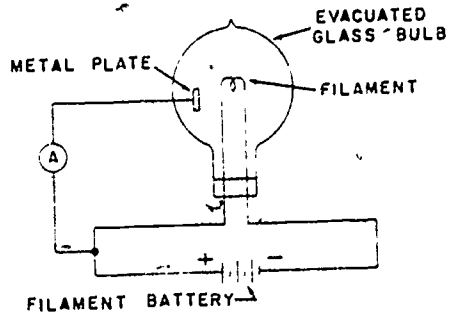


Figure 2-32. Edison's experiment.

2-2. Use of Electronic Controls

Electronic control is here to stay. It has been over 20 years since heating and air-conditioning systems were first controlled electronically. Over the years, electric control has been extensively applied by engineers, designers, and building owners to their systems. Although once electronic control was thought to be too technical for the average serviceman to repair, it has become evident that the adjustment and maintenance is actually simpler than for those of the more traditional control systems—pneumatic and electric.

228. Define the theory of electronics and state characteristics of vacuum tubes.

Electronics can be defined as the science dealing with the control of electron flow, especially by means of electron (vacuum) tubes. The terms "electron tube" and

"vacuum tube" are used interchangeably to refer to a tube in which a flow of current takes place in an enclosed space. A vacuum tube is one from which the air has been removed to form a partial vacuum. However, in some cases certain gases are introduced inside the tube. Although the enclosed space is not a vacuum, these gas-filled tubes are included in the category of vacuum, or electron tubes.

There are numerous types of vacuum tubes manufactured; each type differs from the other and has specific characteristics. Likewise, there are many types of electrical devices used in combination with vacuum tubes to make up the field of electronics.

Edison's electric lamp is the forerunner to all vacuum tubes. A few years after Edison invented his first lamp, he noticed that a dark deposit was formed on the inside of the glass bulb when direct current flowed through the

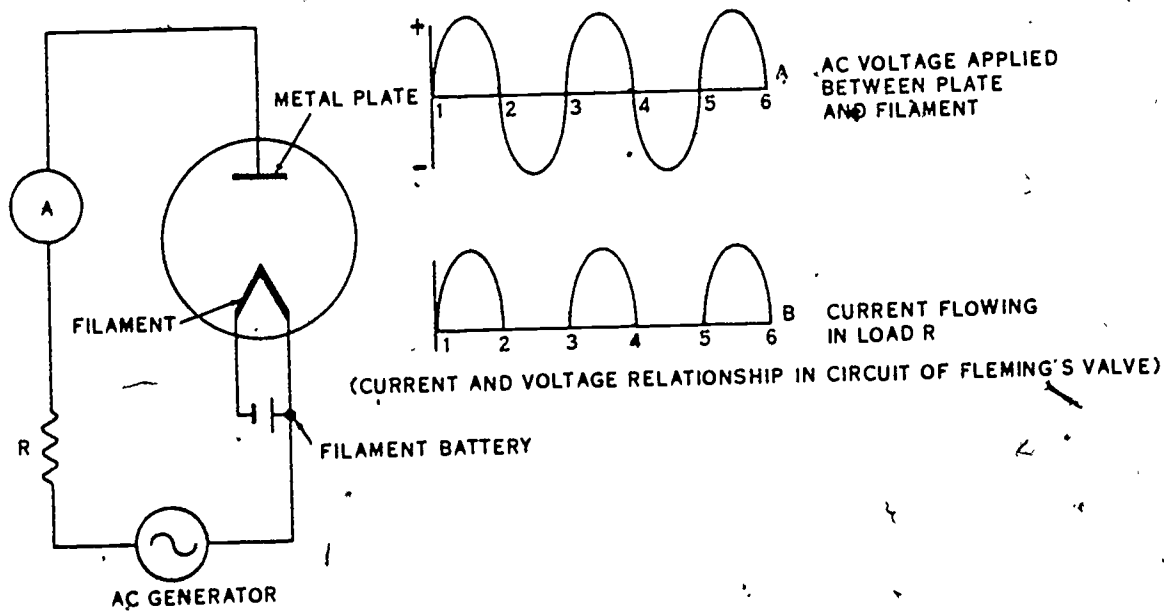


Figure 2-33. Fleming's valve.

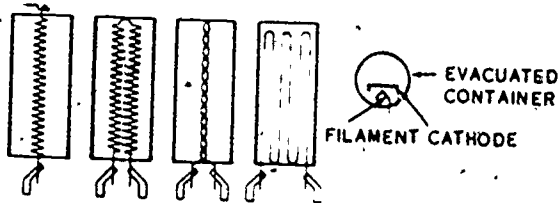


Figure 2-34. Indirect heated cathodes.

bulb filament. In an attempt to eliminate this deposit, a metal plate was placed inside the bulb. A sensitive meter was connected between the metal plate and the filament. To Edison's amazement, a current flow was indicated by the meter. Edison's experiment is illustrated in figure 2-32.

In the year 1904, John Fleming explained Edison's experiment by the electron theory. He constructed a circuit similar to Edison's. He reasoned that the heated filament in the bulb was emitting negatively charged particles (electrons). He reasoned that if the emitted particles were negative, then a positive charge would attract them. He placed a battery between the metal plate and the filament. He found that current flowed from the metal plate when it was connected to the positive terminal of the battery and the filament was connected to the negative terminal. He found, however, that no current flowed when the battery between the plate and the filament was reversed.

Next, Fleming replaced the battery with an ac generator, as shown in figure 2-33. He found that although he used an ac generator, the current that flowed from the plate was a direct current. Current flows during the portion of the ac cycle when the plate is positive with respect to the filament; during the portion of the cycle when the plate is negative, no current flows. As a result, current flow from the plate is a pulsating direct current, as illustrated in figure 2-33. Since the circuit acts like a valve, permitting current to flow in only one direction, Fleming called it a valve.

Electron Emission. All vacuum tubes have one characteristic in common: free electrons are forced to leave the surface of a conductor and enter the space around it. This is referred to as electron emission. There are several types of emission. Perhaps the most important is thermionic emission. When certain metals are heated, the electrons become so active that they escape from the surface of the metal. The surface from which the electrons escape is called the emitter or cathode.

Emitters. There are two types of emitters, or cathodes—directly heated and indirectly heated. In directly heated cathodes, a wire is heated by passing a current through it, and electron emission takes place directly from the wire's surface. In some instances the wire is not heated evenly, and the electron emission is not uniform. This difficulty in direct heated cathodes led to the development of the indirectly heated cathode. Figure 2-34 shows you four types of indirectly heated cathodes and the schematic representation. The cathode consists of a loop of tungsten wire inserted in a thin-walled metal cylinder. As the tungsten wire is heated by the passage of an electric current, it in turn heats the metal cylinder. The cylinder emits electrons evenly.

If an emitter is heated to the required temperature in air, it oxidizes and is destroyed in a short time. For this and other reasons, it is necessary to enclose all the elements of a vacuum tube in a space as free of air as possible.

The amount of current that flows from the cathode to the plate in a vacuum tube depends upon two factors—the temperature of the cathode and the potential difference (voltage) between the cathode and the plate. The distance between the cathode and the plate also affects the amount of current, but of course this distance is determined by the manufacturers of the tube.

Diode Vacuum Tube. Every vacuum tube must have at least two elements or electrodes—a cathode and an anode (plate).

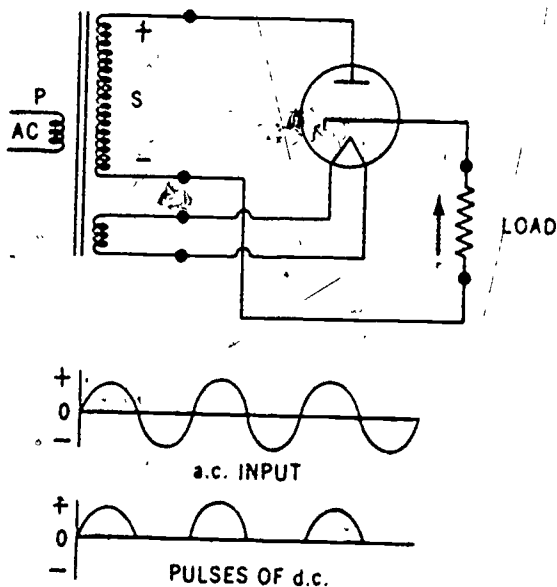


Figure 2-35. A simple electronic circuit.

The plate is the electrode toward which the electrons emitted by the cathode are attracted. The material, size, shape, and location of the plate vary. However, in much the same manner that an indirectly heated cathode surrounds a heater, a typical plate consists of a conductor which completely surrounds the cathode.

A two-electrode vacuum tube is called a diode, a tube containing three electrodes is called a triode, a tube containing four electrodes is called a tetrode, and so on.

Fleming's valve, which we have just discussed, was actually a simple diode tube. Since a diode conducts only when its plate is positive with respect to a negative cathode, an ac signal applied between the plate and the cathode produces a direct current. A diode may therefore be used as a rectifier.

Figure 2-35 shows you a simple electronic circuit with a load resistor in series with a diode tube. This arrangement supplies a direct current through a load. Notice that the circuit is supplied by an ac power source through a transformer and that the diode contains an indirectly heated cathode. When the ac power supply is on the positive alternation of the sine wave (shown at the bottom), the plate has a positive potential applied and the cathode has a negative potential. From previous discussions you know that such conditions are necessary for the tube to operate. As the plate voltage increases, so does the plate current. At the highest point on the ac sine wave, the potential difference between the plate and the cathode is at maximum; therefore, maximum current flows through the tube. The current drops to zero as the positive alternation of the sine wave drops to zero. On the negative alternation, no current flows through the load resistor

because the plate is no longer positive with respect to the cathode. Then, during the next positive alternation, the plate becomes positive and the cathode becomes negative, and there is current flow again. The diode tube is essentially a half-wave rectifier and produces a pulsating direct current as illustrated at the bottom of figure 2-35. Diode tubes may be combined to produce full-wave rectification, or a duodiode tube may be used.

Exercises (228):

1. Define the theory of electronics.
2. What do all vacuum tubes have in common?
3. What must all vacuum tubes have to emit and attract electrons?

229. Name the components of an electronic control system and identify the component that energizes the motor and valves.

Electronic control offers a large number of advantages. For example, the sensing elements have simple construction. There are no moving parts, thus providing dependable operation. Also, the regulatory element (controlling mechanism) is normally some distance from the sensing elements. Therefore, adjustments can be made at a central location. Temperature averaging can

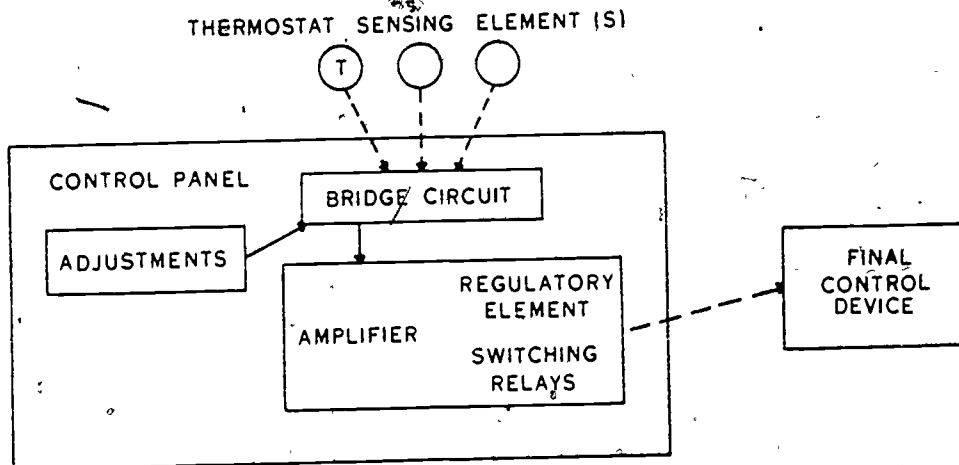


Figure 2-36. Basic electronic control system.

$1000 \times .0022 \times 1 = 2.2 \text{ ohms}$

We then subtract 2.2 from 1000 for each degree fall in temperature.

$1000 - 2.2 = 997.8 \text{ ohms at } 73^\circ \text{ F.}$

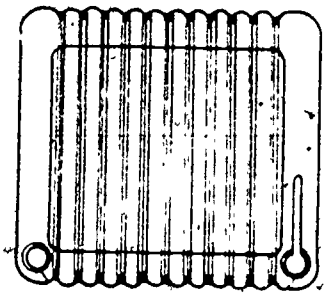


Figure 2-37. Electronic sensing element.

be accomplished by wiring two or more sensing elements in series. This series arrangement then may be connected to the regulatory element through electric and electronic circuitry. Only simple low-voltage is required between the sensing element and the electric circuitry.

Basic Electronic Control Circuit. The basic circuit is comprised of one or more thermostats (sensing elements) leading to a control panel. Located within the control panel is the bridge circuit, amplifier, and the regulatory element (switching relays). Conductors from the panel to the final control device complete the circuit. Let's look at figure 2-36 to determine what takes place.

When a temperature change takes place at the thermostat(s), this unbalances the bridge circuit. The amplifier then increases the resultant voltage change, which in turn energizes the switching relays. The energized relay(s) will activate one or more final control devices to regulate the manipulated variable according to demands of the sensing element(s) within the thermostat(s).

Electronic Controller. The electronic thermostat is the controller and, like all thermostats, is temperature sensing. It also initiates the corrective impulse to the final control device (motor or valve). The first function is performed by the sensing element and the second by the regulatory element.

Sensing element. The sensing element is a coil of fine wire wound on a bobbin, as shown in figure 2-37. Resistance of the wire varies directly with the temperature. The type of wire most often used has a (resistance varying directly with the temperature) coefficient of about .0022 ohms, per ohm, per degree F. Thus, if the air temperature falls 1°, a 1000-ohm sensing element with resistance measured at 74° F. will have a resistance of 997.8 ohms at 73°. To come up with this figure, we multiply the resistance rating of the sensing element by the wire coefficient by 1 ohm.

Regulatory element. In electronic temperature control circuits, this element may consist of one or more switching relays. These relays start one or more electric motors or motorized valves. Also, they may consist of a relay-actuated pneumatic valve unit that can start a pneumatic final control device. The regulatory element itself is actuated by voltage that has been amplified from an unbalanced electric bridge circuit.

Remember, a temperature increase or decrease at the thermostat unbalances the bridge circuit. Remember, also, that output voltage from an unbalanced bridge is fed into a voltage amplifier unit, and that the output from the amplifier activates the regulatory element (switching relay of air valve). The regulatory element opens or closes the final control device, depending upon whether the bridge voltage fed to the amplifier is in phase or out of phase with the supply voltage.

The Wheatstone Bridge. The nerve center of most electronic control systems is a modified Wheatstone bridge. Before discussing this particular bridge, keep in mind that a bridge circuit is nothing more than a potentiometer or combination of potentiometers. In simple bridge circuits, the resistances are connected in parallel with their wipers. But in the more complicated Wheatstone bridge, shown in figure 2-38, only one variable resistor is used in conjunction with three fixed resistors:

Most controls manufacturers use an ac-voltage bridge circuit adapted from the Wheatstone bridge. The variable resistor has a higher resistance value than the three fixed

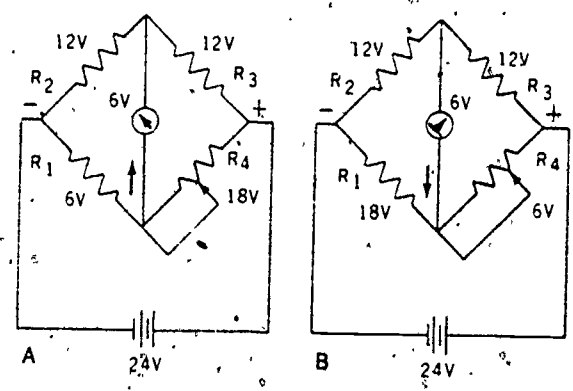


Figure 2-38. Operation of the Wheatstone bridge.

resistors. When the variable resistor is centered, it has the same value as the fixed resistors and the bridge is in balance. In figure 2-38,A, we see an unbalanced bridge to the left; in figure 2-38,B, an unbalanced bridge to the right, with voltmeters connected to each.

Each resistor drops 12 volts. In figure 2-38,A, R_4 is unbalanced to the left. Due to its higher resistance, it now drops 18 of the applied 24 volts, with the remaining 6 volts dropped by R_1 . The difference between 6V and 12V, or between 12V and 18V, is 6V across the meter. Since current flows from negative to positive, the flow through the meter is up, as indicated by the arrow. In figure 2-38,B, R_4 is unbalanced to the right. This drops its value, causing most of the applied voltage (24V) to be dropped across R_1 (18V). The difference between 12V and 18V is 6V across the meter, but flows down as indicated by the arrow.

The Wheatstone bridge can be used on ac or dc. In the previous illustrations, a dc circuit was shown. When installed in an ac circuit, the power source is replaced by a transformer, and the voltmeter with an amplifier. The amplifier simply "builds up" the small signal from the bridge to operate a relay.

Exercises (229):

1. List the components of an electronic control system.
2. What is the nerve center of an electronic control system?
3. What component energizes motors and valves?

230. Identify the types and uses of meters.

The test equipment recommended for checking out new installations and for routine troubleshooting of electronic control systems is dc voltmeters (1000 ohms per volt or greater) range: 0-150 volts. Any good multimeter can be used to measure ac and dc voltages, check for continuity, short circuits, and grounds.

An oscilloscope is a very useful item of test equipment. It is an electronic instrument, primarily used for bench testing of electrical

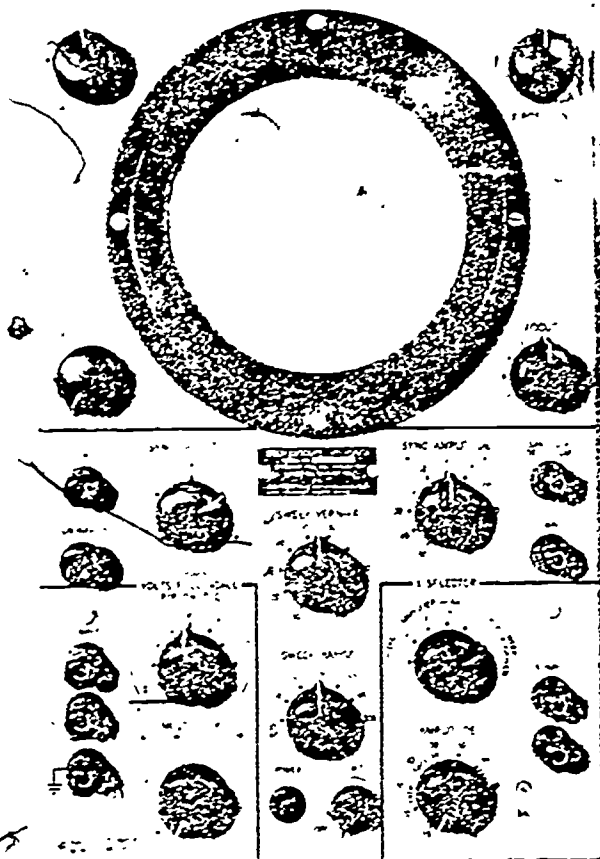


Figure 2-39. Oscilloscope.

and electronic circuits and components. The oscilloscope has many applications, such as measuring frequency, determining the amplitude (maximum value) of a voltage, and monitoring the waveforms of voltage. In many circuits the waveform of a voltage is more important than the average value. To make these waveforms visible, an indicating device must be able to move as fast as the changes in the applied voltage. This requirement is met by the cathode-ray oscilloscope, one type of which is shown in figure 2-39. Instead of a deflecting pointer moving across a calibrated scale, it deflects a stream of electrons which trace a pattern of light on the screen of the cathode-ray tube. This tube replaces the moving parts of an electric meter. The cathode-ray oscilloscope not only indicates an electrical signal, but shows the changes in that signal with respect to time.

Think of all the electronic and electrical actions you have seen depicted by lines, graphs, and curves. Then imagine an instrument that automatically and instantly forms such curves directly from electron flow and makes them clearly visible. The oscilloscope makes visible the rise, fall, and

reversal of alternating voltages and electron flows of practically any frequency. It doesn't make any difference whether the curves vary, repeat over and over again in cycles, or occur irregularly. The oscilloscope also does the same for pulsating or dc voltages and electron flows. With the help of the oscilloscope, you may directly observe peak voltages, breakdown voltages, momentary changes of supply voltages, and voltage gains in amplifiers. With suitable transducers you may observe things related to time, such as high speed, vibration, phase differences, and the number of cycles in operation. You may also watch the action of electronic tubes, sound waves, and changes in magnetic or electrostatic fields.

Always refer to the manufacturer's instructions before you attempt to use a particular oscilloscope. Operating instructions tell you how to connect the oscilloscope for testing various circuits and components and how to read the various patterns on the screen. Do not attempt repair and internal adjustment of an oscilloscope. Use only the external controls for adjustment and operation of the instrument.

Exercises (230):

1. What meters are normally used to check electronic control systems?
2. What functions does the oscilloscope perform?

231. Given a hypothetical situation, solve troubleshooting problems on electronic control systems.

The electronic control system has definite characteristics—flexibility, sensitivity, simplicity, speed, and accuracy—that show to best advantage in a heating system where signals from several controllers must be coordinated to actuate a series of control motors and valves. Each controller is a component of a modified Wheatstone bridge circuit. A change in the controlled variable will cause a change in the voltage across the bridge. This change in voltage is detected by an electronic relay which starts corrective controlled device action. The magnitude of voltage change and the resulting device movement are a result of the amount of controlled variable change.

Authority "pots" in the control panel adjust the change in variable required at a controller to give a certain voltage change. For example, an outdoor thermostat might be adjusted to require a 10° temperature change to give the same voltage change as a 1° change at the room thermostat. For the remainder of this discussion, let us consider temperature as the controlled variable.

Voltages resulting from a rise in temperature differ in phase from voltages resulting from a drop in temperature and therefore can be distinguished. Voltages resulting from temperature changes at several thermostats are added in the bridge if they are of the same phase, or subtracted if they differ in phase. The total voltage determines the position of the final controlled device. Each controller directly actuates the final controlled device.

All adjustments for setting up or changing a control sequence can be made from the control panel. The panel may be maintained in any readily accessible location. Selection of control, with its broad range, replaces several conventional controls, where each has a smaller range. Troubleshooting a suspected defective electronic control device can be speeded up by relating apparent defects to possible causes. For example, when you first turn on the power, all the tubes should light up and become warm. An abnormal condition would exist if one or two of the tubes remained cool, or the tubes should light up and burn out, or if the transformer should heat and smoke. To troubleshoot an abnormal condition, you would check for bad tubes, faulty bridge or amplifier circuits, faulty connections between the amplifier and bridge,

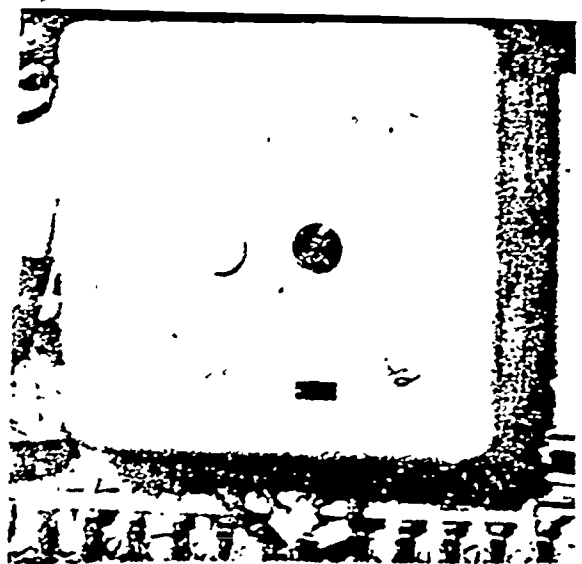


Figure 2-40. Relay (cover on).

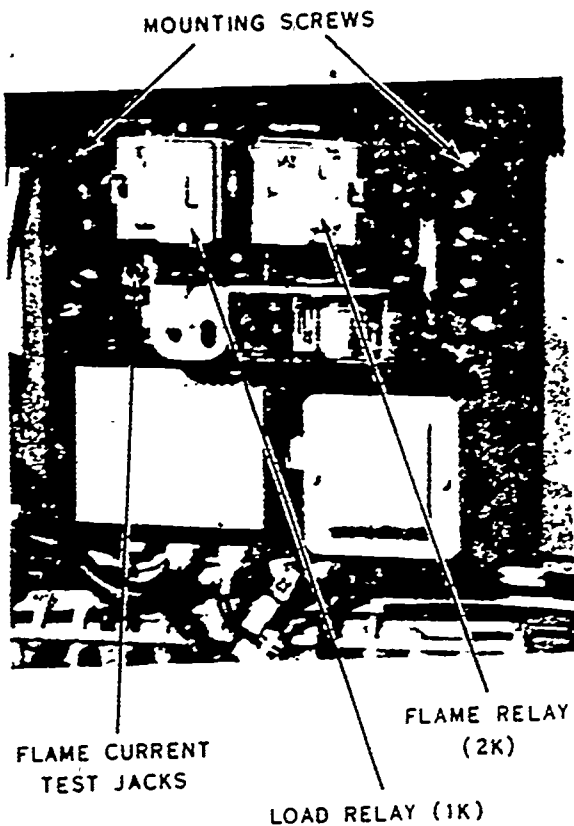


Figure 2-41. Relay (cover removed).

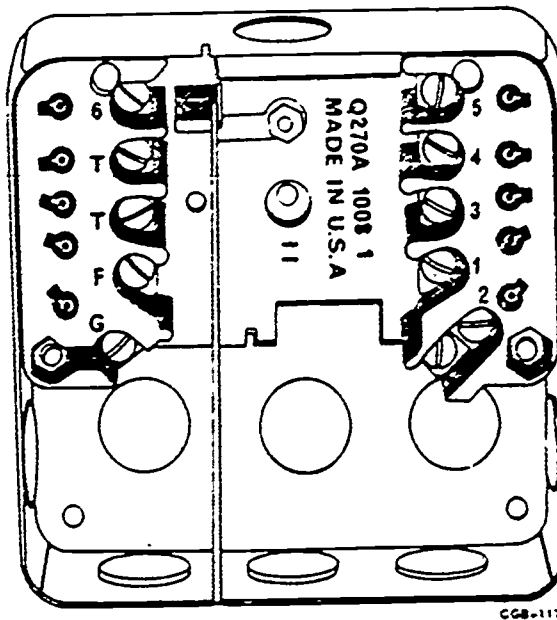


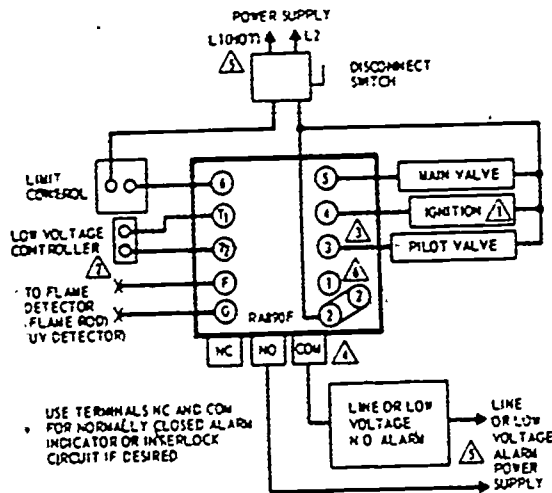
Figure 2-42. Relay subbase.

faulty power terminal connections, power supply of improper voltage, or opens or shorts in a circuit.

Another example would be checking the amplifier and bridge. During normal operation, adjusting the control point adjuster varies the output voltage. If the adjustment has little or no effect on the output voltage, you should check for a faulty bridge circuit, faulty amplifier, faulty plug-in between the amplifier and bridge circuit, open in wiring or a shorted sensing element, or weak tubes.

Exercises (231):

1. You are visually checking an electronic control system. You find 2 tubes are not lighted. What would be your next steps?
2. If in adjusting the control point, you find there is no variance in the output voltage, what would your troubleshooting procedures include?



- ⚠ FOR INTERMITTENT IGNITION CONNECT TO TERMINAL 3
- ⚠ IF LINE VOLTAGE CONTROLLER IS USED CONNECT IT BETWEEN THE LIMIT CONTROL AND TERMINAL 5 JUMPER T1 AND T2
- ⚠ HOOKUP FOR STANDING PILOT IS THE SAME AS FOR INTERRUPTED IGNITION EXCEPT IGNITION AND PILOT VALVE CONNECTIONS ARE NOT MADE
- ⚠ SPDT ALARM TERMINALS OPTIONAL IF LINE VOLTAGE ALARM IS USED RARPOF MUST BE MOUNTED IN SUITABLE ENCLOSURE
- ⚠ POWER SUPPLY—PROVIDE OVERLOAD PROTECTION AND DISCONNECT MEANS AS REQUIRED
- ⚠ FOR RARPOF REPLACEMENT LEAVE POWER CONNECTED TO TERMINAL 1 SUBBASE WIRING CHANGES ARE NOT REQUIRED

C-GF-012B

Figure 2-43. Gas system (interrupted ignition).

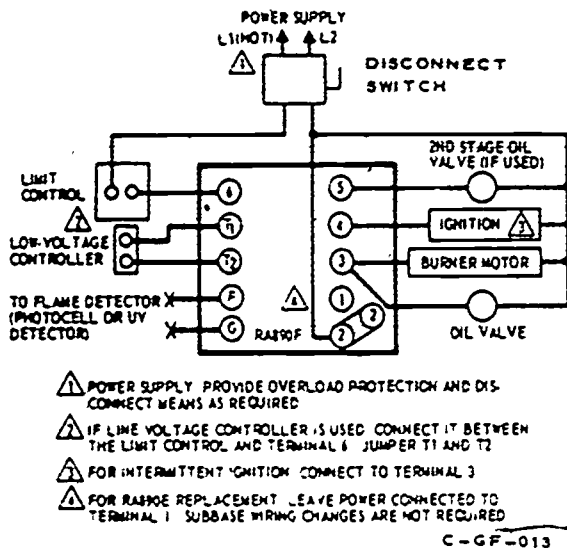


Figure 2-44. Oil system (interrupted ignition).

232. Cite two types of electronic control system components and state functions necessary in their removal and replacement.

The component of an electronic control system that we will discuss first is the RA 890F (primary control), as shown in figures 2-40, 2-41, and 2-42. These controls use the rectification principle of electronic flame detection, using either a flame rod, a rectifying photocell, or the C7012A Ultraviolet Flame Detector. They provide solidstate electronic safeguard protection for industrial and commercial gas, oil, or combination gas/oil burners. They are dependable, economical, nonprogramming, amplifying relays. Solid-state circuitry eliminates vacuum tube replacement and increases resistance to vibration. No warmup is required.

Figure 2-42 shows Q270A subbase. It is used for all RA890 series controllers. All wiring connections are made to the subbase. Figures 2-43 and 2-44 show wiring diagrams for gas- and oil-fired equipment. If it becomes necessary to substitute for a later model control, no wiring change is necessary unless so stated in instructions for a particular control. Figure 2-41 shows the control with the cover removed. You can see the physical locations of the 10 mounting screws that are the only means of contact between the relay and subbase. Also, the Load Relay (1K), and the Flame Relay (2K) are pointed out. The flame current test jack is another important item shown in this illustration. The other component is the programming control, type

26RJ8 in the FP-2 system, that we will discuss next. This system provides ignition and flame failure protection for industrial and commercial oil, gas, or combination oil/gas burners. In conjunction with operating, limit and interlock devices, it automatically programs each starting, operating, and shutdown period. The FP-2 system consists of a Type 26RJ8 programming control and a Type 48PT1 scanner that uses the Firetron cell to visually supervise both oil and gas flames.

The FP-2 system monitors both main and pilot flames and does not permit the main fuel valve to be energized unless pilot flame has been established and proved. With an alternate connection for burners having direct spark ignition, the unsupervised trail-for-ignition period is precisely restricted to a safe short interval.

The 26RJ8 control programs the operation of blower and/or burner motor, ignition system, fuel valve, and modulator system in a proper sequence that includes suitable purge periods before ignition and after burner shutdown. Additionally, it is designed to deenergize all fuel valves within 1 to 4 seconds upon loss of flame signal. The control recycles automatically each time the operating or limit control closes, or after a power failure, but locks out and must be reset manually following flame failure.

The FP-2 system incorporates a

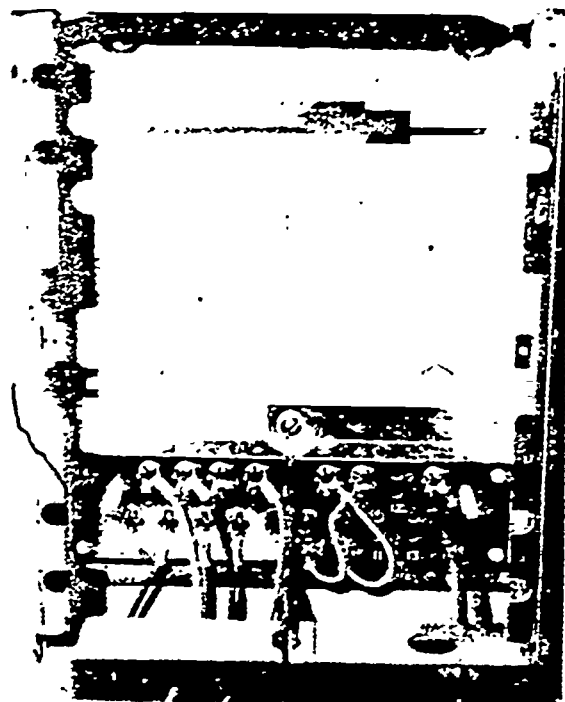


Figure 2-45. Mounting base (programmer).

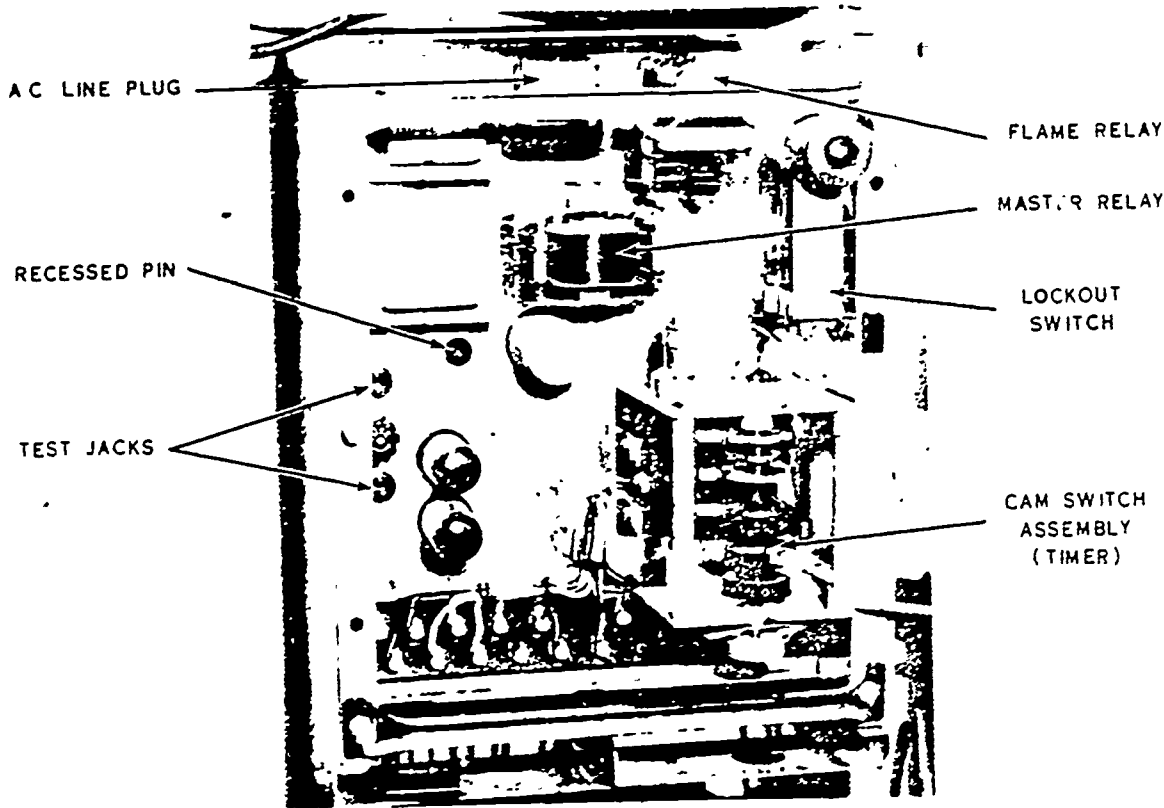


Figure 2-46. Programing control.

safety-checking circuit that is effective on every start. Any condition that will cause the flame relay to hold in during the checking period will stop the program before any ignition circuits are energized and, if sustained, will result in safety lockout.

All wiring connections are made to the terminal panel at the bottom of the housing. (See fig. 2-45.) Separate knockouts are provided for conduit connections for line voltage and scanner circuits. Generally, models may be interchanged without changing any wiring connections. However, you must verify all wiring connections before operating. The control chassis plugs securely into the housing and is secured by the two thumb screws. (See fig. 2-46.) The scanner may be located up to 100 feet from the control. Continuous conduit bonding between scanner and control is mandatory. Do not pass scanner wiring through any junction box containing other wires, and do not run other wires through scanner conduit. The reason for this is that stray voltage from the other wires can affect the scanner signal.

Exercises (232):

1. Name the two electronic control system components that use flame controls.

2. The RA890F control is removed and replaced in which manner?
3. The FP-2 system is removed and replaced in which manner?

233. State maintenance fundamentals of the RA890F control and FP-2 system.

Maintenance of the RA890F. Only qualified personnel should attempt to service heating equipment or controls. Perform all checks required under the CHECKOUT section of the manufacture's instructions. When cleaning the burner, clean the flame detector. Do not push in the relays manually. **CAUTION:** The captive mounting screws carry current; always disconnect the power before loosening or tightening the mounting screws.

The specific maintenance schedule set up will depend upon a number of factors, including the type of equipment being controlled, the operating conditions (dirt and heat especially), the cost of a nuisance shutdown, etc. The following should be included in any program:

- a. Replace the vacuum tubes in the C7012 Flame Detector (if used) annually.
- b. Perform a flame-failure check and pilot turndown test whenever the burner is serviced, and at least annually.
- c. Inspect and clean the detector and any viewing windows as often as soot accumulation and heat conditions at the detector make it necessary.
- d. Do a flame current check at least monthly, and more often where a shutdown may be costly.
- e. Clean contacts only when required by failure to operate properly.

Maintenance of the FP-2 System. All relay contacts are designed with adequate wiping action for self-cleaning under normal conditions. In atmospheres carrying excessive dust or oily vapors, contacts may require occasional cleaning. Use only a fine grade of crocus cloth for cleaning. Do not file. To protect against high-resistance leakage in the electronic circuit resulting from high humidity, it is recommended that the control be left powered continually even when not in

operation. If it is necessary to shut down completely for an extended period, power should be turned on for 48 hours before putting the control back in operation. It is recommended that units purchased as spares be rotated periodically, so that each unit will be placed in operation at least every 90 days, to ascertain that the spare unit is in working order. This will prevent possible deterioration of a unit stored over a period of years.

Exercise (233):

1. What are the basic maintenance fundamentals of the RA890F control and the FP-2 system?

2-3. Use of Pneumatic Controls

Controlling the heating effect is one of the greatest problems in air conditioning. Therefore, automatic controls are used to solve this problem by sensing and controlling the amount of heating or cooling. An

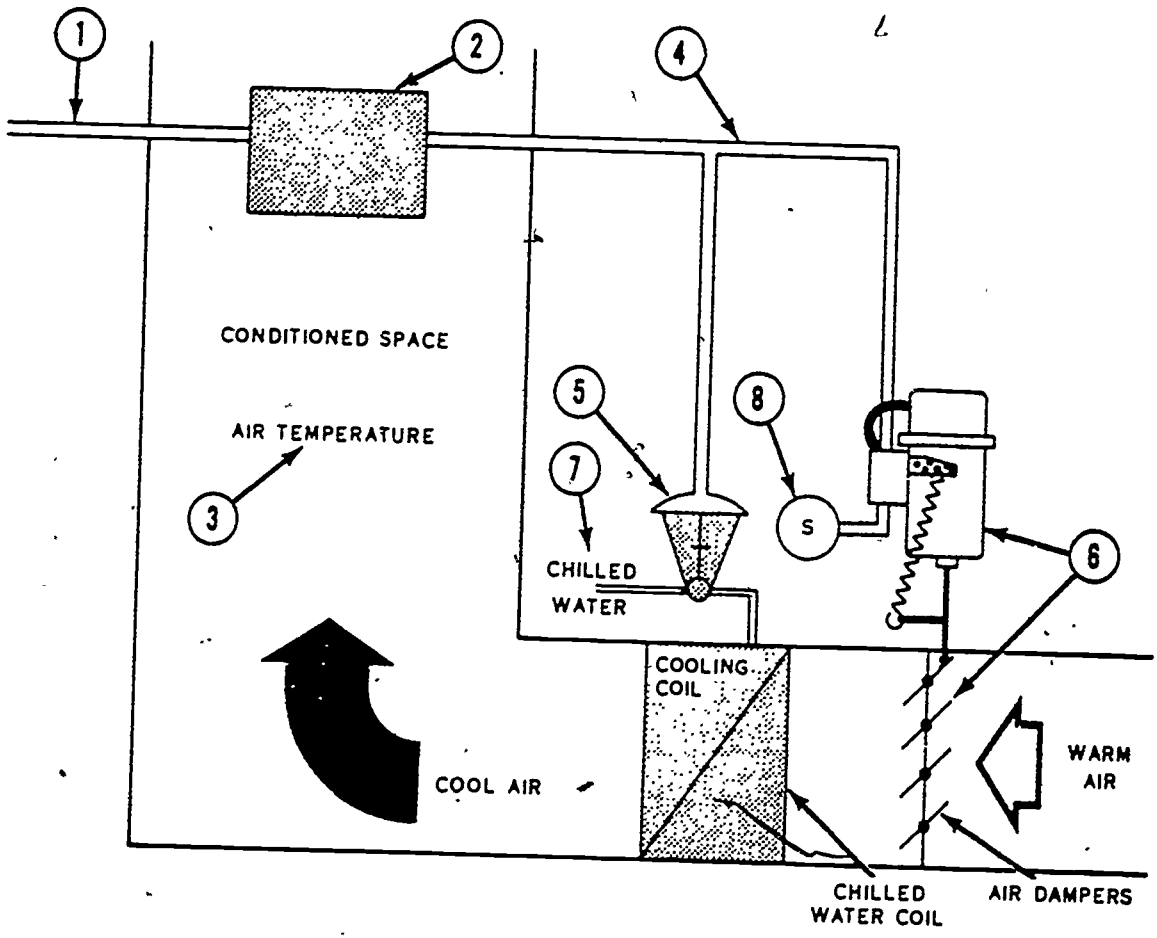


Figure 2-47. Control loop showing control terms.

automatic control system must have some type of energy for operation. Pneumatic controls use compressed air for operating, whereas electric and electronic controls use electricity. It would take many sections to cover pneumatic controls completely, since the applications are practically unlimited. They are used in the automatic control of temperature, relative humidity, pressure, liquid levels, airflow, and other applications.

234. Define pneumatic terms.

A working knowledge of terms common to controls plus the operating theory is essential to permit you to operate and adjust pneumatic controls properly.

Controls Terms. Refer to the numbered schematic in figure 2-47 for additional clarification of terms.

- Supply (main air) pressure: The air pressure supplied to a controller. It is usually 15 to 20 psig (see number 1, fig. 2-47).
- Controller: An instrument that senses variations in the controlled variable and produces a corresponding control action: e.g., thermostat, humidistat, or pressure controller (see number 2, fig. 2-47).
- Controlled variable: That which is being controlled—air temperature, relative humidity, pressure (see number 3, fig. 2-47).
- Proportional control: Type of control where the control pressure varies in proportion to changes in the controlled variable and may be any value from zero to maximum.
- Control (branch line) pressure: The output air pressure from a pneumatic controller (see number 4, fig. 2-47).
- Controlled device: The final control element, such as a valve or damper, which is actuated by the controller and regulates the flow or effect of the control agent (see number 5 or 6, fig. 2-47).
- Control agent: The medium regulated by the controlled device—such as steam, hot water, chilled water, and brine—that effects changes in the controlled variables (see number 7, fig. 2-47).
- Control point: The actual value of the controlled variable at any given time.
- Set point: The value for which the controller is set. It is the target value which the controller attempts to maintain.
- Sensitivity: The change in air pressure from a proportional controller per unit change in the controlled variable.
- Throttling range: The change in controlled variable required to produce full movement of the controlled device or devices.

- Normally open: A controlled device that automatically assumes the open position and requires control pressure to close.
- Normally closed: A controlled device that automatically assumes the closed position and requires control pressure to open.
- Spring range: The range over which the controlled device operates (e.g., 5-10 psig).
- Sensing (measuring element): The part of the controller that reacts to changes of the controlled variable.

Theory. To understand the pneumatic control system, it is necessary to identify all the elements that are used to produce the various control effects. While all instrument designers use the same basic elements, their finished products differ considerably in performance, maintenance requirements, and adjustments.

Bleed controls. After the air has been reduced from the source (air compressor), it is fed through a restrictor or small orifice to a leakport. The restrictor opening is smaller than the opening in the leakport. Because of the difference in size of the openings, the pressure will reduce after it passes the orifice. With the lid moved away from the leakport as in figure 2-48, the valve gage reads 0 psi.

A temperature increase causes the lid to move nearer the leakport, and this reduces the amount of air bleeding from the leakport. The air continues to flow through the restrictor; and since the bleeding is reduced, the pressure to the valve increases. The valve opens, causing the temperature to be lowered.

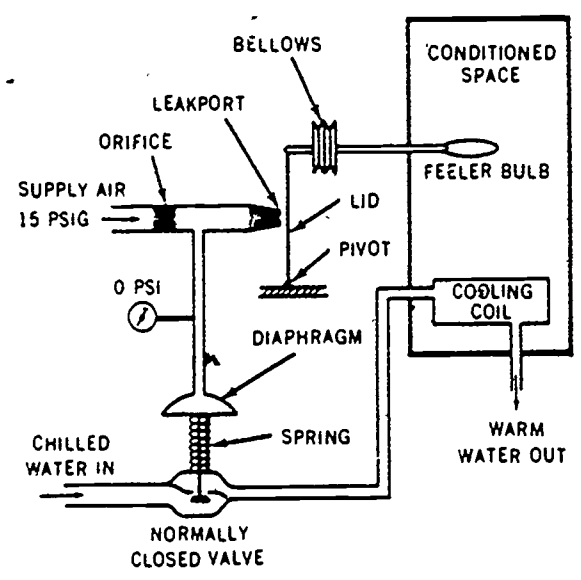


Figure 2-48. Simple bleed control principle.

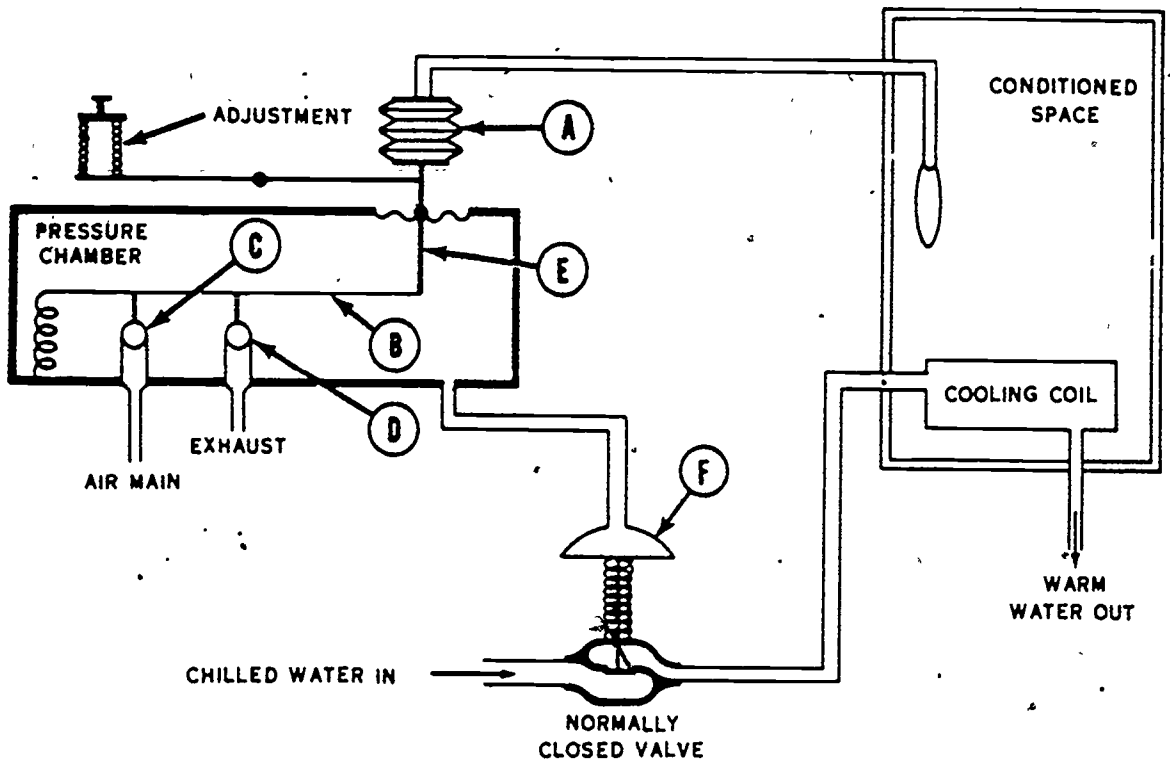


Figure 2-49. Nonbleed control principle.

A decrease in temperature causes the lid to move away from the leakport so that more air can bleed to the atmosphere. Since the restrictor allows only so much airflow, the pressure decreases. This allows the valve to move toward the closed position, reducing the amount of cooling for temperature control.

Do you know why this control is called a bleed type? Think for a minute; can the leakport and the lid make a positive seal? Does the orifice change in size? No. Therefore, in a bleed type, the air bleeds to the atmosphere constantly.

Nonbleed controls. The nonbleed control system is shown in figure 2-49. This type of control uses a valve arrangement which eliminates the constant bleeding of air. It uses air only when the control (branch line) pressure is being increased. Now compare figure 2-49 with figure 2-48 and note the difference between the two types.

Look at figure 2-49 and assume that the space temperature has increased. This expands bellows "A," thus pushing rod "E" and diaphragm "F" down. Exhaust port "D" becomes the pivot point as valve "C" opens. The main air enters the pressure chamber and goes to the normally closed (NC) valve. As the valve moves toward the open position, friction becomes greater, causing the pressure

to increase in the pressure chamber. This pressure increase forces against the diaphragm "F" (pneumatic feedback), forcing rod "E" up until the main air valve is seated. The unit stays in this balanced position until another change occurs in the conditioned space. Now assume that the space temperature drops. Bellows "A" contracts, and rod "E" and diaphragm "F" move up, pulling valve "D" away from its seat, thus allowing the air pressure to escape to the atmosphere. Valve "C" becomes the pivot point. Atmospheric pressure forces diaphragm "F" down until both valves "C" and "D" are closed.

Exercises (234):

1. A unit of a controller that reacts to changes of the controlled variable is termed a _____.
2. What is a controlled variable?
3. What do the terms N.O. and N.C. mean?
4. Name two controlled devices.

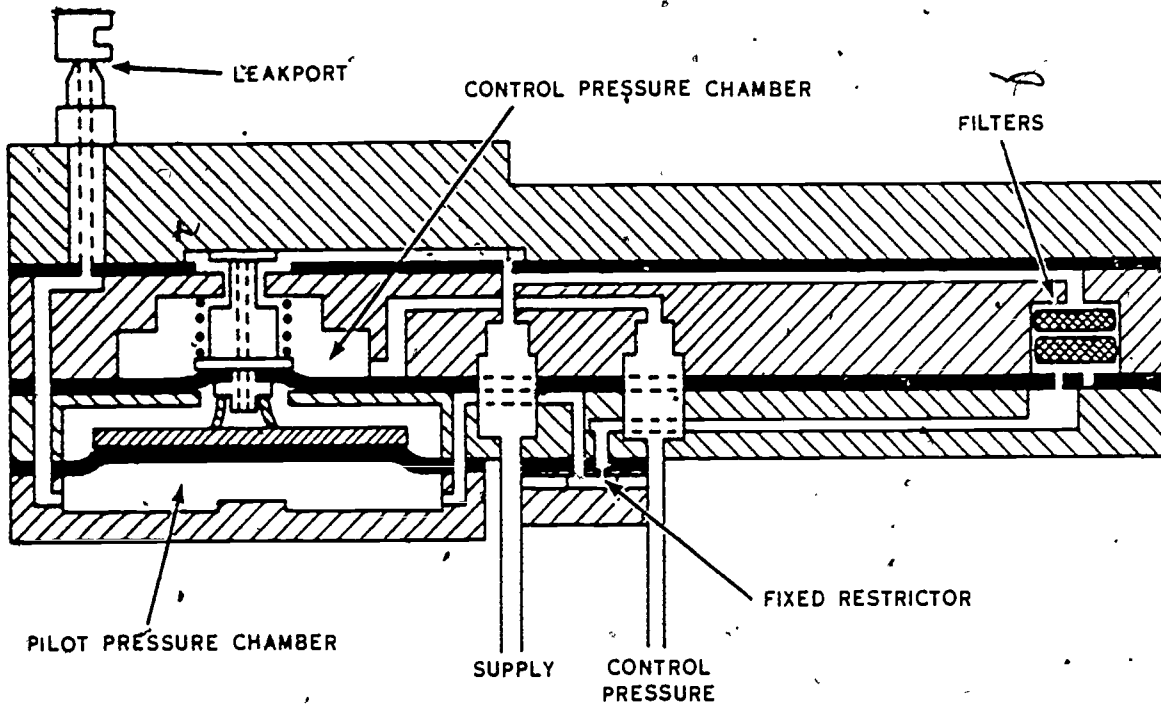


Figure 2-50. Pilot operated pneumatic relay.

- 5. What term represents a thermostat, humidistat, or pressure controller?
- 6. What do the terms "bleed" and "nonbleed" refer to?

235. Differentiate between the Pneumatic Controller Thermostats.

Pneumatic Controllers. The Pneumatic controller is an instrument that senses the temperature, humidity, or pressure, and varies the control pressure to the final controlled device to effect the correction needed. The controller must have a sensing element to sense changes in the temperature, humidity, or pressure and then convert the change into mechanical movement. The mechanical movement causes another part of the controller to change the control pressure going to the final controlled device.

Learning objective 234 covered the simple bleed and nonbleed controllers, and you have seen how the pressure is changed. The simple bleed control is not as accurate as usually desired, but by adding other devices to these controls they become more sensitive to the

controlled variable. You will study about these pneumatic controllers in this objective.

For more accurate control, most controllers use a pneumatic relay. The pneumatic relay uses a pilot pressure (smaller pressure) to control the flow of supply pressure into the control pressure line (higher pressure). The basic pneumatic relay shown in figure 2-50 is used in several pneumatic controllers.

When the leakport is closed by the sensing element, the pressure in the pilot chamber increases and forces the diaphragm assembly upwards. This movement closes the exhaust valve, and then the upper diaphragm valve is lifted off its seat. The supply pressure enters through the diaphragm valve into the control chamber to increase the control line pressure.

When the leakport is opened, the pressure in the pilot chamber will decrease. The spring forces the diaphragm assembly downward and moves the exhaust valve away from its seat. Then, the control pressure enters the exhaust chamber and is expelled into the atmosphere. The control pressure decreases until the exhaust valve closes.

Room Thermostat. A room thermostat is a control device that senses the temperature of an individual room. The thermostat converts a temperature change into a corresponding air pressure (control pressure) change that is sent to a controlled device (valve or damper). The

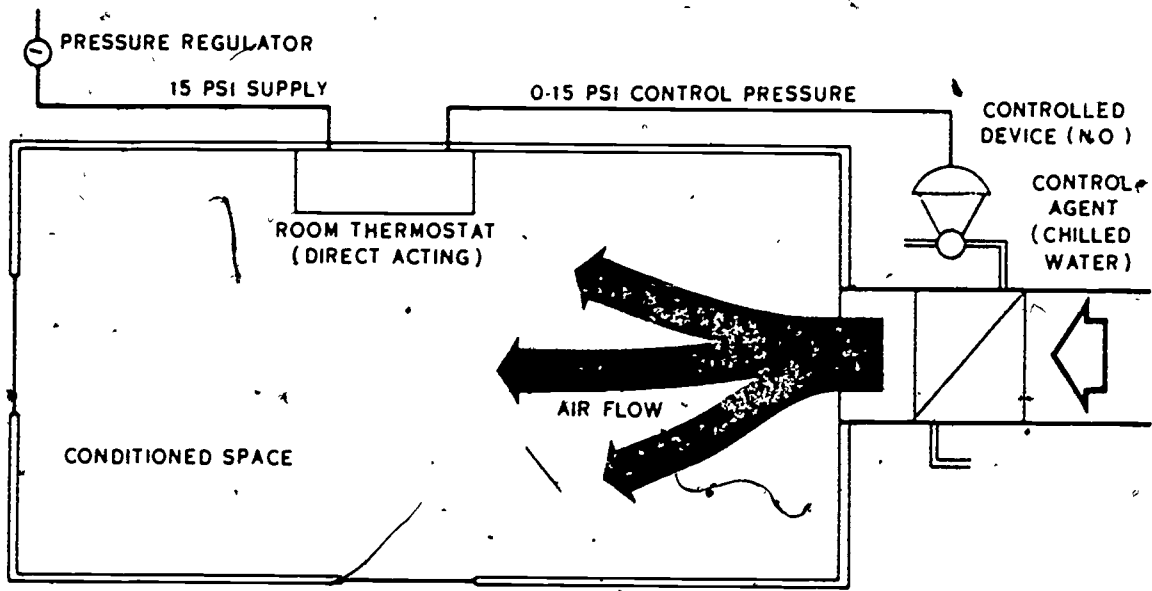


Figure 2-51. Room thermostat application

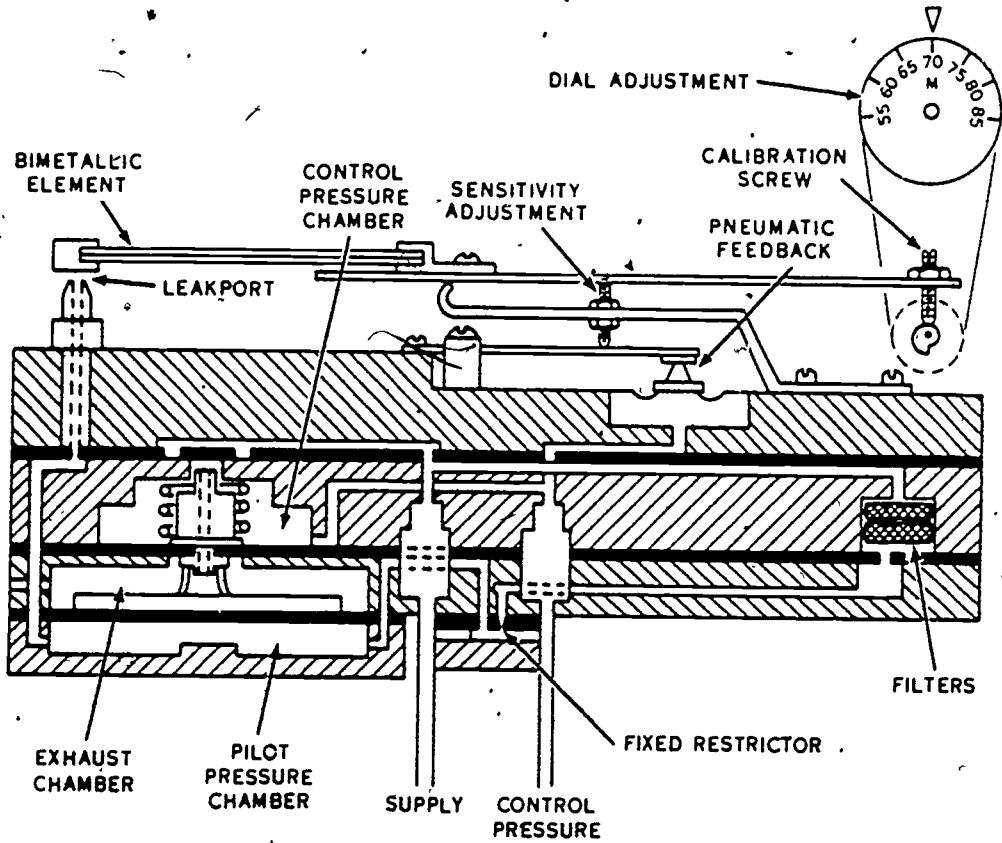


Figure 2-52. Room thermostat.

controlled device regulates the flow of the control agent (chilled water, hot water, steam, etc.) and thereby controls the temperature.

The room thermostat can be used to control automatically the temperature for heating or cooling, but usually only one at a time. The room thermostat is installed on a wall where it will sense the temperature of the room. As you can see from the diagram (fig. 2-51), the room thermostat modulates the chilled water valve to control the temperature of the room supply air. The operation of the room thermostat is very similar to that of the basic pneumatic relay. The room thermostat must have some type of sensing element. A thermostat with a bimetallic element is shown in figure 2-52. When the room temperature increases, one side of the bimetal element expands faster than the other and makes the element bend. When the temperature increases on a direct-acting thermostat, the bimetal element bends down. When the temperature on a direct-acting thermostat decreases, the bimetal element bends up.

The opening and closing of the leakport causes the pilot pressure to increase or decrease. Assume that the thermostat in figure 2-52 is direct-acting, so that a rise in temperature causes a rise in pilot pressure. The control pressure increases proportionally to the rise in temperature, and the controlled device also moves proportionally. This control has a pneumatic feedback which provides proportional control.

The sensitivity adjustment can be moved from one end of the slide to the other to

make the control more or less sensitive. Move the sensitivity adjustment toward the leakport (fixed end). Now, assume that an increase in temperature has taken place. This causes an increase in the control pressure and also the pressure in the pneumatic feedback chamber. With the sensitivity adjustment at the fixed end of the pneumatic feedback arm, the feedback has very little effect on the lid assembly. Because the change in temperature is counteracted only slightly by the feedback, there is a high control pressure change per degree of temperature change.

If the sensitivity slider is moved away from the leakport (to the movable end), a change in temperature has the same effect in the control pressure and in the pneumatic feedback chamber. But now the pressure change has more effect on the lid and moves the lever up. Since the sensitivity slider is at the movable end, the lid assembly is moved away from the leakport. Some of the pilot pressure bleeds off and the control pressure reduces. In this case, therefore, a change of 1° gives less pressure change, which means a lower sensitivity.

Heating-Cooling Thermostat. The operation of the heating-cooling thermostat is very similar to the operation of the room thermostat, but it is used differently, since it is applied for both heating and cooling. It is a controller which senses the temperature of an individual room. The heating-cooling thermostat converts temperature changes into pressure in the same manner as the room thermostat. The heating-cooling thermostat is

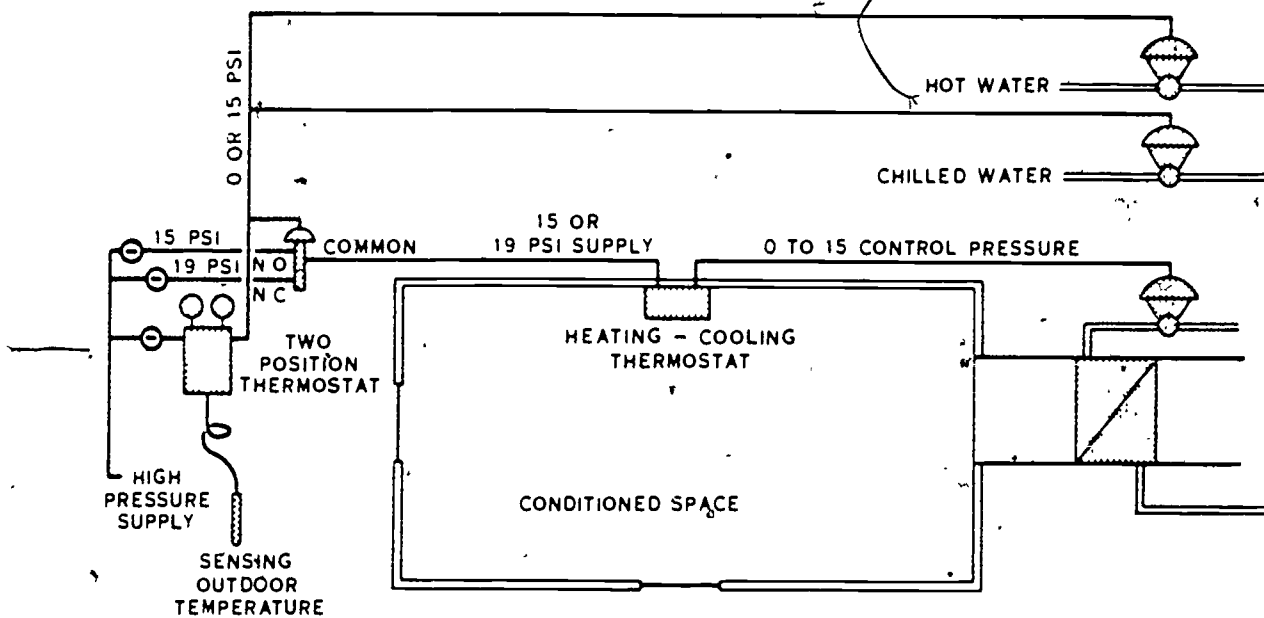


Figure 2-53. Application of a heating-cooling thermostat.

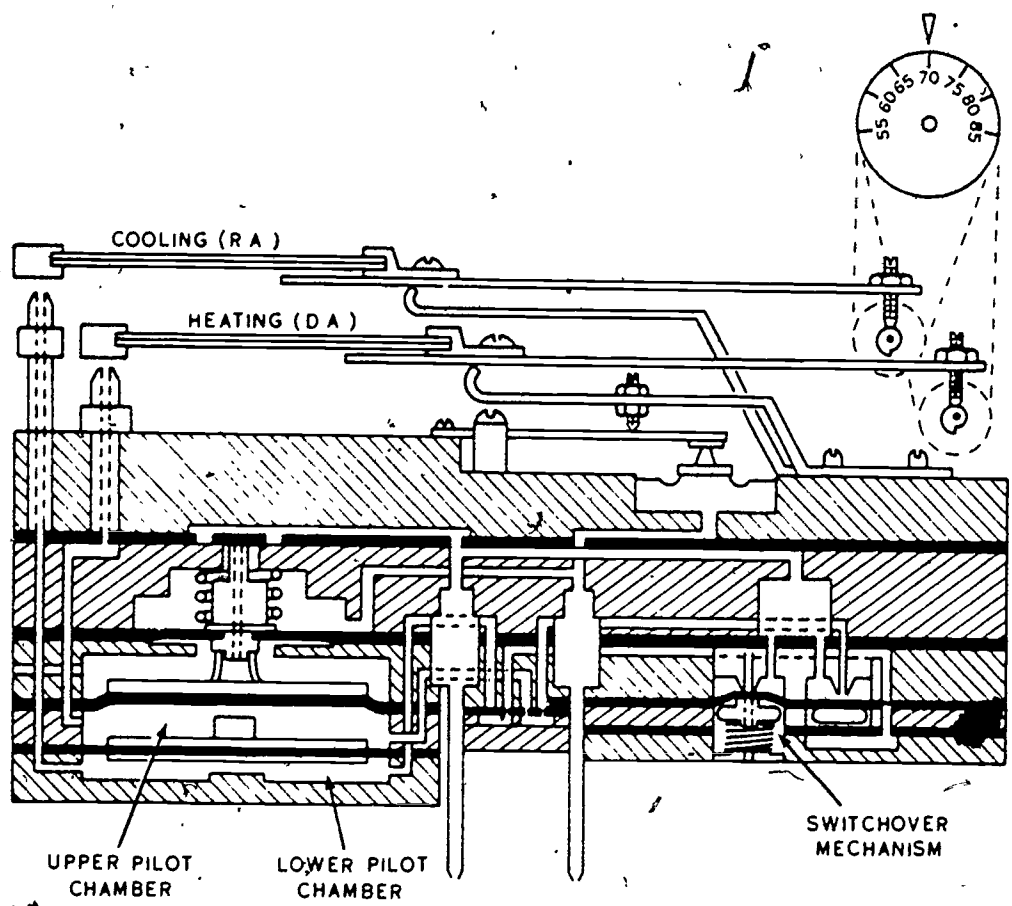


Figure 2-54. Heating-cooling thermostat.

a combination of two room thermostats (a direct-acting and a reverse-acting) in one thermostat. In reality, it is a room thermostat that uses direct-acting for control of heating in winter and reverse-acting control for summer cooling. This controller is also referred to as a summer-winter thermostat.

The heating-cooling thermostat is used to control the temperature automatically for heating and cooling. An application of this thermostat is shown in figure 2-53. It is installed on a wall, where it will sense the temperature of the room. The controller modulates the controlled device to control the flow of chilled water in the summer and hot water in the winter.

Heating. The thermostat becomes a heating thermostat when the supply pressure is 15 psig. Looking at figure 2-53, you can see that the 15 psig supply comes to the controller when the outdoor thermostat senses a cool temperature. Look at figure 2-54 and you will see that the thermostat has two sensing (bimetallic) elements. The 15 psig supply goes through the switching mechanism to supply the pilot pressure to the upper pilot chamber

and then goes out of the corresponding leakport. The lower sensing element bends down on a rise in temperature, which gives a rise in control pressure. This is direct action and is used for heating. This part of the controller modulates the controlled device to regulate the amount of hot water for heating the air.

Cooling. The thermostat becomes a cooling thermostat when the supply pressure is raised to 19 psig supply when the outdoor thermostat senses a hot temperature. The rise in supply causes the switchover mechanism to send pilot pressure to the lower chamber. The pilot pressure escapes from the other leakport. The upper sensing element works just the opposite in that it bends upward and lowers the pilot pressure on a rise in temperature. The controller is now reverse acting and is used for cooling. This part of the controller modulates the controlled device to regulate the amount of chilled water for cooling the air.

There are many other controls that are incorporated in the pneumatic system. As emphasized before, to cover all pneumatic

controls would take section after section and could not possibly be completed in this course.

Exercises (235):

1. What is a thermostat?
2. What is the difference between a room thermostat and a summer-winter thermostat?

236. Name the procedures for adjusting a pneumatic control system component and show where to obtain information for repair.

Adjustment of a Room Thermostat. The adjustment of a room thermostat is an important part of your job. Control of the temperature is impossible if the thermostat is not properly adjusted. The following are the basic steps in the adjustment of the room thermostat (fig. 2-52):

- (1) Remove the capscrew and install a control line test gage, as shown in figure 2-55.
- (2) Set the dial to the ambient temperature (control point).
- (3) Turn the adjusting screw until the control pressure is at the middle of the spring range of the controlled device to the 1/2 opened position.
- (4) Turn the dial to the desired temperature (set point), remove the test gage, and replace the capscrew. For other types, refer to the manufacturer's instructions.

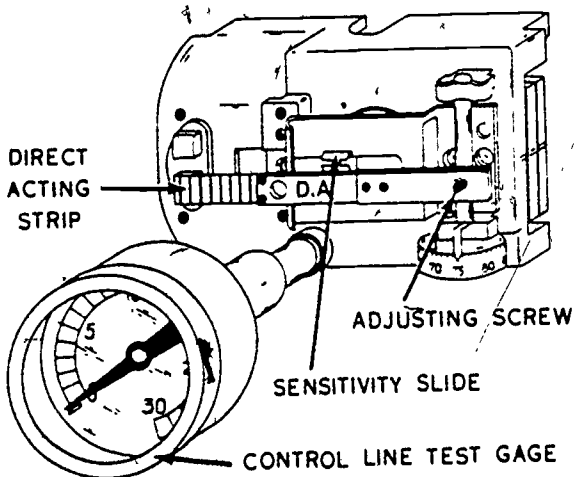


Figure 2-55. Room thermostat with a test gage installed.

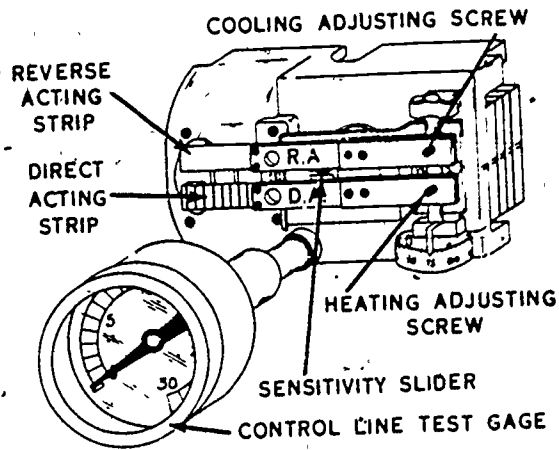


Figure 2-56. Heating-cooling thermostat with a test gage installed.

Adjustment of a Heating-Cooling Thermostat. The adjustment of a heating-cooling thermostat is another important part of your job. Control of the temperature in a room in summer and winter is impossible if the thermostat is not adjusted properly. The sensitivity is adjustable on this instrument in exactly the same way that it is on the room thermostat. Following are the basic steps in the adjustment of the heating-cooling thermostat in figure 2-54.

- (1) With 15 psig supply air pressure applied to the instrument, remove the capscrew and insert a control line test gage into the opening, as illustrated in figure 2-56.
- (2) Check the ambient temperature at the sensing elements.
- (3) Set the dial at this temperature.
- (4) Turn the heating adjusting screw until the control pressure is in the middle of the spring range of the controlled device.
- (5) Turn the dial to the desired temperature set point for the heating cycle.
- (6) Change the supply air pressure to 19 psig.
- (7) Again check the ambient temperature at the sensing elements. Note the following conditions:
 - (a) If the desired cooling set point is not the same as the heating set point, determine the difference between the ambient temperature and the desired cooling set point.
 - (b) If the ambient temperature is higher than the desired cooling set point, ADD the difference (step (a)) to the heating set point, and turn the dial to this value.
 - (c) If the ambient temperature is lower than the desired cooling set point, SUBTRACT the difference (step (a)) from

the heating set point, and turn the dial to this value.

(8) Turn the cooling adjusting screw until the control pressure is in the middle of the spring pressure range of the controlled device.

(9) Turn the dial back to the desired heating or cooling set point, remove the gage, and replace the capscrew. Turning the dial will now change both set points the same amount. For further adjustment procedures and information on repairing all pneumatic control system components, refer to the manufacturer's instructions.

Exercises (236):

1. Name procedures for adjusting a room thermostat.
2. List procedures for adjusting a heating-cooling thermostat.
3. Before any type of repair is started on a component of a pneumatic system, you should obtain information where?

Pipe and Copper Tubing

DIFFERENT TYPES of pipes and fittings are used in the installation of a heating system. Each type of pipe or fitting is made for a specific use, depending on the installation and its requirements. Some pipes and fittings are made in different weights and strengths for use in gravity or pressure systems. In either case they are made so that they can be installed to provide watertight, gastight, or airtight joints. Many materials are iron, steel and copper. Plumbing and heating practices and the physical characteristics of these materials are the basis for establishing specific uses for each type of pipe or fitting.

Copper pipe and tubing, instead of steel or iron pipes, will be required by specifications on some jobs. Either hard drawn or annealed types of copper pipe or tubing are used for service lines and underground lines, or when concrete or other hard surfaces will cover the pipe. Some heating mechanics prefer to use the hard drawn type rather than the annealed copper, because it makes a more rigid and neater job. Either type can be used.

Copper pipe and tubing have become very popular with the mechanics because of the ease with which they can be installed and assembled. Only a relatively small number of tools are required to install copper pipe and tubing as compared to galvanized or black iron pipe. The major tools needed for copper are a tubing cutter or a hacksaw, and a torch and solder.

It is important for the heating mechanic to have a good knowledge of fitting iron, copper, and steel pipe. First, he must study his blueprints and plan his job so that the proper materials and equipment for the job will be procured. The loss of time and materials can be prevented if the correct fittings are procured first. A good mechanic will always prepare a check list to insure that the proper tools and equipment are on hand, and also that the job is properly planned before it is started.

3-1. Fundamentals of Piping

Different types of pipes and fittings are used in the installation of a heating system. Each type of pipe or fitting is made for a specific use, depending on the installation and its requirements. Some pipes and fittings are made in different weights and strengths for use in gravity or pressure systems. In either case they are made so that they can be installed to provide watertight, gastight, or airtight joints. Many materials are available for use in installing permanent heating systems. Among those commonly used are wrought iron, steel, brass, and copper. Plumbing and heating practices and the physical characteristics of these materials are the basis for establishing specific uses for each type of pipe or fitting.

237. From given information, determine kind, amount, and class of pipe needed to install a gasline to a warm-air furnace.

A pipe for heating and plumbing purposes is a hollow cylinder used for conveyance of liquids or gases and is usually threaded at the ends for coupling. Pipe that is used by the heating specialist is measured by the inside diameter.

Black Iron (Uncoated). Black iron pipe is composed of mild steel mixed with cast or pig iron. This type of pipe is most commonly used by the heating field. It is used for compressed gases (air, gaseous fuels), steam and condensate returns, and oil. However, it is not recommended for sewerlines, because of rust and stoppage.

Steel. Steel pipe is a composition of scrap iron.

Galvanized (Coated). Coated pipe is either black iron or steel pipe that has been dipped in a zinc bath solution. It is used for hot and cold water distribution, and drain lines. It is not normally used for natural gaslines because of the flaking action of the zinc coating.

There are three classes of pipe used for heating systems: (1) standard weight (this class will withstand pressures up to 125 psi), (2) extra strength (will withstand pressures up to 250 psi), and (3) double extra strength (which withstands pressures up to 600 psi).

Pipe that you may use will be measured by inside diameter (ID) in sizes from 1/2 inch to 12 inches. However, the most common sizes you will work with are 3/8", 1/2", 3/4", 1", 1 1/4", 1 1/2", and 2". All pipe comes in an average length of 21 feet.

Exercise (237):

1. Determine the kind, amount, and class of pipe needed to install a gasline to a warm-air furnace.
 - a. From regulator to furnace is 100 feet.
 - b. Gas pressure approximately 30 psi.

238. Cite the types and function of pipe fittings.

Pipe fittings are measured by inside

diameter and the size is proportionate to the outside diameter of the pipe. EXAMPLE: A 1/2" fitting will accommodate a 1/2" pipe although the inside diameter of the fitting may be 3/4". Pipe fittings are fabricated in malleable iron for use with steel pipe and in black iron or galvanized. Fittings for brass pipe are plain or chrome.

Although there are many different types of pipe fittings, the most common fittings known to the heating specialist are illustrated in figure 3-1.

The following explains the sizes and uses of each pipe fitting listed in figure 3-1.

1. Elbows

- a. Female threads (inside)
 - b. 90° - makes a 90° change in direction
 - c. 45° - makes a 45° change in direction
 - d. 90° and 45° street elbows
 - (1) One female and one male thread
 - (2) Allows for close installation of fittings.
 - (3) Eliminates a pipe nipple
- e. Reducing elbow
 - (1) 90° and 45°
 - (2) Two female threads
 - (3) Used to reduce from one size to another

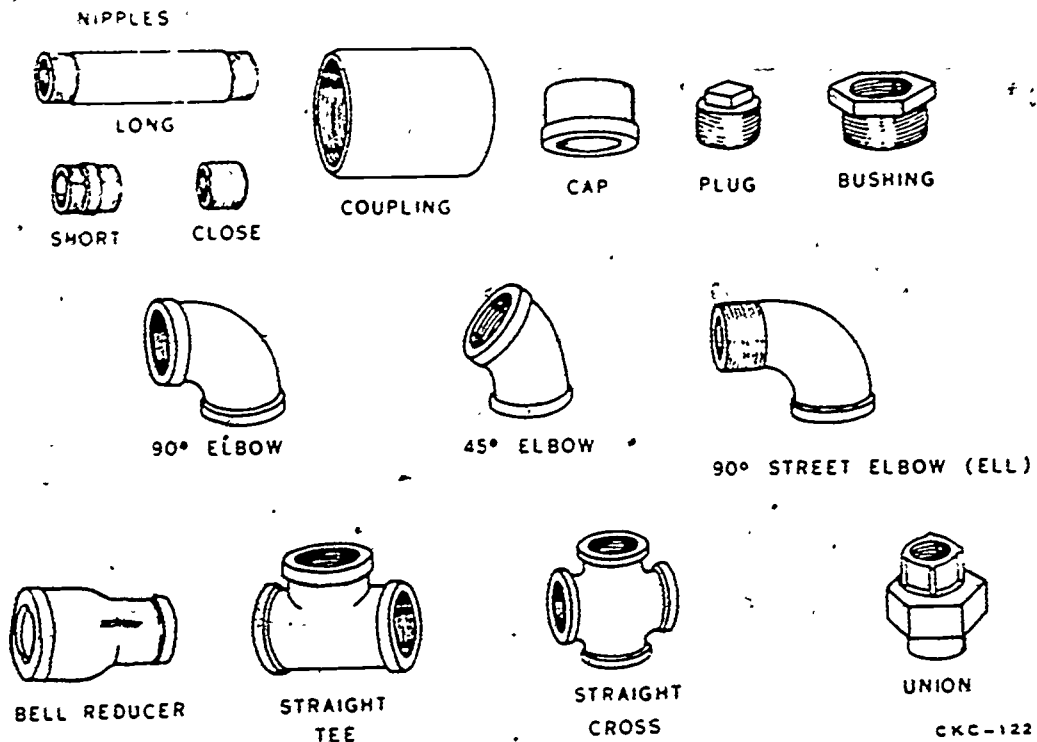


Figure 3-1. Types of pipe fittings.

- 2. Tees
 - a. Three female threads
 - b. Used to pick up a branch run at a 90° angle
 - c. Reducing tees
Used to couple three lines of different sizes
 - d. Service tee
 - (1) Two female and one male thread
 - (2) For close installation
 - (3) Eliminates use of a nipple

- in a valve or fitting
- (3) Read largest male thread end first
- b. Bell reducer
 - (1) Two female threads
 - (2) Used to make reduction in run of pipe

- 3. Cross Tee
 - a. Four female threads
 - b. Four outlets 90° apart
 - c. Used on most steam boilers below and above water column

- 4. Unions
 - a. Ground joint or machined face
 - b. Two female threads
 - c. Facilitates removing or installing a section of pipe or equipment

- 5. Couplings
 - a. Female threads
 - b. Joins straight runs of pipe
 - c. Straight or plain coupling
 - (1) Furnished with each length of pipe
 - (2) Serves as a thread protector

- 6. Nipples
 - a. A piece of pipe less than 12" long, threaded on both ends
 - b. Close nipple (all-thread)
Threaded full length
 - c. Short nipple (shoulder)
Threaded both ends with a shoulder between
 - d. Long nipple
Two to twelve inches long
 - e. Nipples are used where short pieces of extensions of pipe are required

- 7. Pipe plug
 - a. Male thread on one end only
 - b. Square or hexagon head
 - c. Used to close off an opening in a valve of fitting

- 8. Pipe cap
 - a. One female thread
 - b. Used to close off an opening on a piece of threaded pipe

- 9. Reducers
 - a. Bushing
 - (1) One female and one male thread
 - (2) Used to reduce size of an opening

Exercises (238):

- 1. What size pipe fitting will fit a 12" piece of 1" threaded pipe?
- 2. A "tee" pipe fitting is used for what purpose?
- 3. What function is a "union" designed for?
- 4. What sizes do nipples come in?
- 5. What is the purpose of a "bushing" and a "bell reducer"?

239. Identify operational features and characteristics of valves in heating systems.

Because of the number of valves which appear in heating installations, a thorough knowledge of the maintenance and repair of these valves is necessary. Inspection of any valve consists of close examination for visible wear and breakage. Valves are used in piping systems to regulate or control flow in the pipes. The following information is to help you identify valves as to size, threads, and markings.

- 1. Size—measured by inside diameter
- 2. Two female threads
- 3. Body markings
 - a. WOG—Water, oil, or gas
 - b. WSP—Working steam pressure
 - c. Safety precautions to be observed when installing valves
 - (1) Unmarked valves (brass)
 - (2) Can be used for maximum of 125# psi or 450° F. temperature.

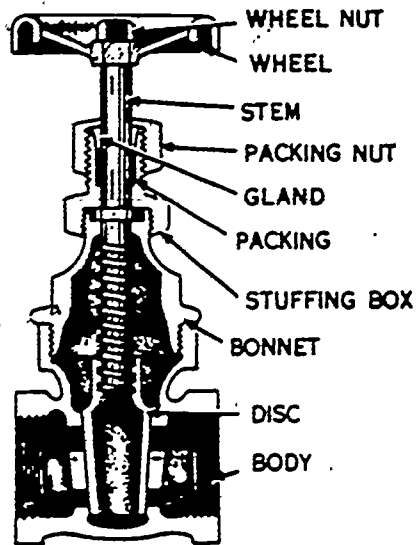


Figure 3-2. Non-rising stem gate valve.

d. Some valves have arrows stamped in the body; install in proper direction

Gate Valve. A gate valve is one of the most used valves. A gate valve is illustrated in figure 3-2 and contains a sliding disc which moves vertically and seats between and against two seats to shut off the flow.

A threaded stem is used to lift or lower the disc, to open or close the valve. The volume of flow through the valve, however, is not in direct relation to the number of turns of the handwheel. Gate valves have a single, solid wedge-shaped disc, and may be provided with either rising stems or nonrising stems. See figures 3-2 and 3-3. Gate valves are used for services where the valve is kept either fully opened or fully closed. To prevent binding, this type of valve should be closed 1/4 to 1/2 turn from fully opened position, and opened 1/4 to 1/2 turn from a fully closed position.

Gate valve leaks may occur at the valve seat, around the stuffing box, and at the body-bonnet joint. Repairs should be made at the first sign of a leak. Tightening a leaking joint will often correct the condition. Other remedies are the replacement of gaskets or renewable parts, repacking stuffing boxes, and regrinding valve seats.

The stuffing box holds the packing which seals the bonnet against leaks around the stem (see figures 3-2 and 3-3). Pressure is applied on the packing by a packing nut or gland flange, which bears on a gland in the stuffing box. Packing wears in direct relation to service condition. It loses life with age, but wear is mainly due to rising and turning

motion of the valve stem. Generally, packing lasts a long time and needs little attention. Stuffing box leaks can usually be stopped by tightening down on the packing nut or gland of the valve. On bolted glands, care must be exercised to tighten the bolts evenly, since cocking the gland will bind the stem. If a stuffing box leak cannot be remedied by tightening the packing nut, the packing must be replaced.

Inability to close a valve tightly is an indication of a valve seat leak. Trouble of this sort is usually caused by scale, metal particles or other foreign matter in a line. Occasionally, it comes from a cut in the seat or disc caused by a high velocity flow of fluid through a limited area where the valve is not fully closed. When valve seat leaks occur, the seat and disc may be repaired provided the damage is not too extensive. If the disc is made of soft metal, it may be refaced (lapped) by using a mixture of oil and lapping compound on the machined surface as an abrasive to replace the disc. By using a figure eight motion, the two surfaces are lapped true to each other.

Gate valves are available in many styles and sizes. They are designed to meet all needs from low pressures to high pressures. They are manufactured to receive screwed, welded, sweated, and flanged piping.

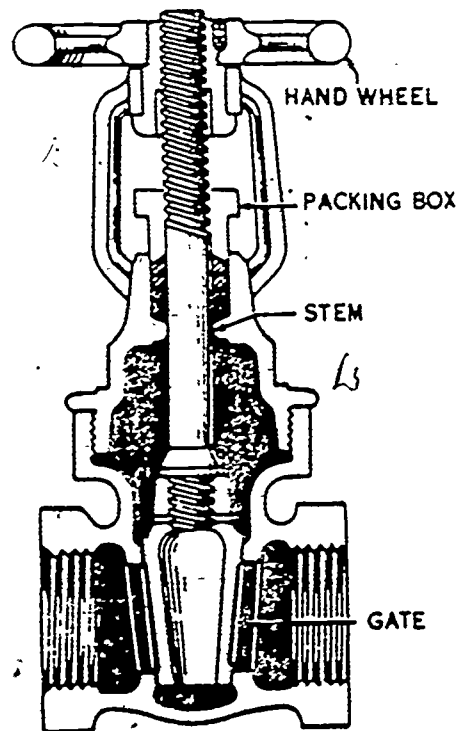


Figure 3-3. Rising stem wedge disc gate valve

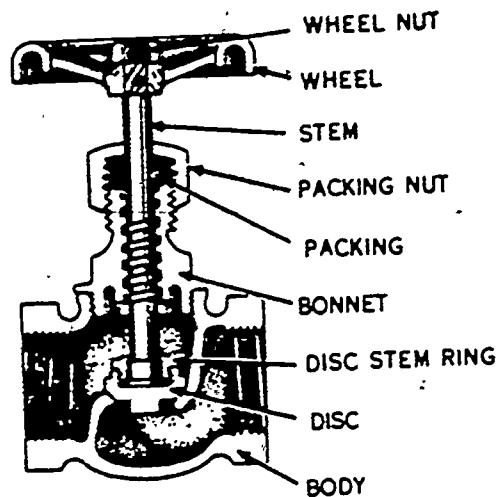


Figure 3-4. Globe valve with a conventional disc.

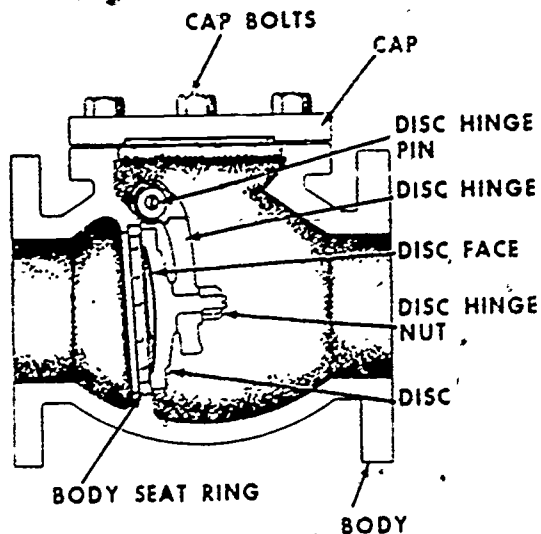


Figure 3-6. Swing check valve.

Globe Valve. A globe valve, as illustrated in figure 3-4, has a horizontal interior partition which shuts off the inlet from the outlet except through an opening in the partition (see figures 3-4 and 3-5). The lower end of the valve stem holds a replacement fiber or metal disc shaped and fitted to close the hole in the horizontal partition. The valve is closed by turning the handwheel clockwise until the disc presses firmly on the opening. The volume of flow through globe valves is roughly proportionate to the number of turns of the handwheel. Globe valves may be provided with either flat or beveled valve seats, depending upon the type of disc.

A plug-type disc consists of a tapered plug

which provides a wide area of seating contact. This type of valve seating provides a very effective means of flow control and offers high resistance to the cutting effects of dirt, scale, and other foreign matter.

A conventional disc, which forms a relatively narrow contact with the valve seat, provides a more positive and higher pressure contact than a wide seat. The thin line contact breaks down hard deposits that form on valve seats and insures a pressure-tight closure. The conventional disc is made in several seating styles, such as flat seating, ball seating, and with seating surfaces having varying degrees of taper.

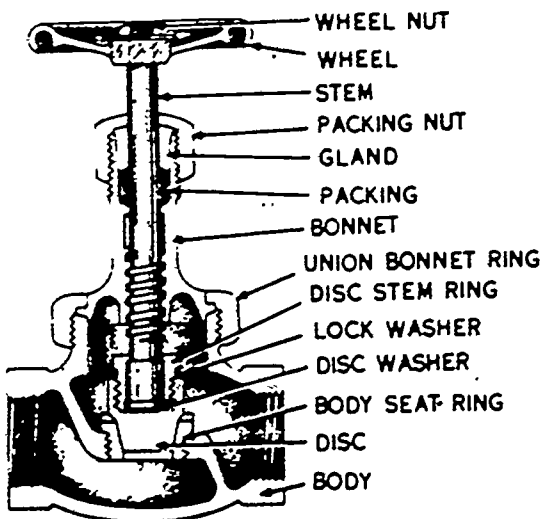


Figure 3-5. Globe valve with a plug disc.

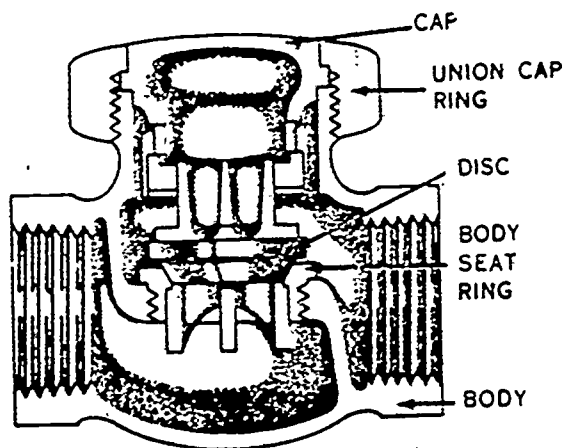


Figure 3-7. Lift check valve.

A composition disc operates on the principle of a cap. Its face seats against or into the valve opening. Most composition discs consist of three parts: a metal disc, a holder, the disc itself, and a retainer nut. The main advantage of a composition disc is the variety of disc materials available for individual services such as air, hot or cold water, gas, oil, gasoline, and other applications. Globe valve leaks occur at the same points as they do on gate valves.

When valve seat leaks are found in plug-type or conventional discs, the valves can be repaired by removing the disc, inserting a washer under it, and then lapping to make a snug fit.

Valve seat leaks in composition disc globe valves are corrected by replacement of the discs. If the seat is severely pitted, the entire valve should be replaced.

Stuffing box leaks are corrected in the same manner as for gate valves. If tightening the packing nut does not stop the leak, replace the packing.

Check Valve. A check valve, as illustrated in figure 3-6, is used when it is necessary to control the flow in one direction only. Fluid flow in the proper direction keeps the valve open and reversal flow closes it automatically (see fig. 3-6 and 3-7). For installation purposes, most check valves are marked to indicate the inlet opening or direction of flow. There are two basic types of check valves: swing check valves and lift check valves. Each type has several variations that make them suitable for specific plumbing installations. A swing check valve should be used in conjunction with a gate valve and a lift check valve with a globe valve.

Swing check valves contain a hinged disc which seats against a machined seat in the tilted bridge wall opening of the valve body (see fig. 3-6). This disc swings freely on its hinge pin in an arc from a fully closed position to one parallel with the flow. The fluid or gas in the pipeline enters below the disc. Line pressure overcomes the weight of the disc and raises it, permitting continuous flow. If the flow is reversed or back-pressure builds up, this pressure is exerted against the disc, forcing it to close and stop the flow.

Lift check valves contain a disc which seats on a horizontal bridge wall in the valve body (see fig. 3-7). The disc is raised from its seat by the pressure of the fluid flow and moves vertically to open. To insure proper seating and rising, the disc is provided with short guides, which are usually above and below the disc. The valve is closed by backflow, or by

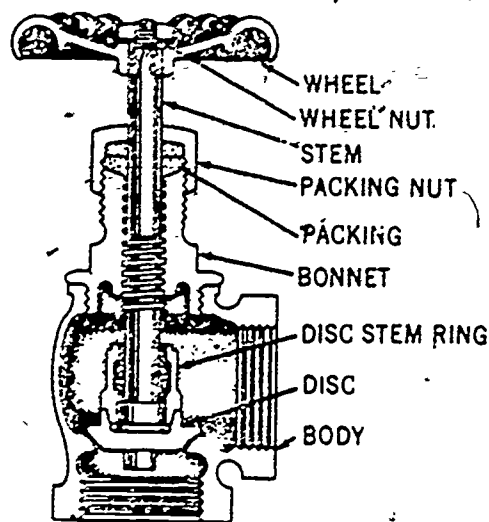


Figure 3-8. Cross section of an angle valve.

gravity when there is no flow.

Check valve leaks occur due to sticking parts or pitted valve seats. To operate properly, the valve disc must fit firmly in its seat. Valve seats can be reground with a reseating tool or by lapping.

Angle Globe Valves. Angle globe valves are similar in construction and operation to globe valves, except that the valve outlet is at an angle of 90° to the inlet. The same repair procedures as used on globe valves should be followed (see fig. 3-8). This type of valve is used on radiators or convectors.

Plug Valves. Plug valves have a circular, tapered, ground plug fitting, and a tapered hole or seat (see fig. 3-9). An opening through the plug permits the passage of fluid through the valve when the opening is alined with the pipeline. Plug valves may be completely and quickly opened by a one-quarter turn of the handle and do not have soft packing, which tends to wear.

Leaks in plug valves can usually be corrected by cleaning or by adding a special lubricant. The lubricant makes it easier to turn the valves and also seals the points where the plug does not seat perfectly. If the valve seat is severely pitted, the entire valve must be replaced.

Exercises (239):

1. Define the term "125 WSP."

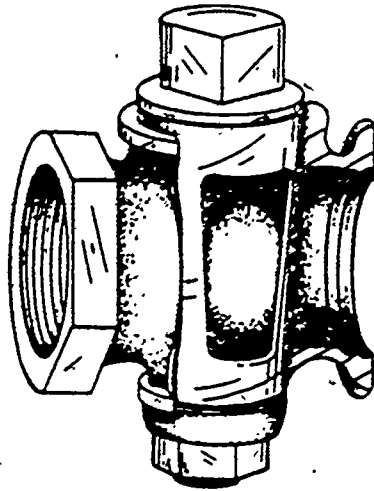


Figure 3-9. Cross section of a plug valve.

2. In which areas do gate valves most commonly develop leaks?
 3. For what purpose would you install a globe valve?
 4. How do you determine which direction to install a check valve?
 5. Which type of valve is used on a hot water radiator?
 6. What characteristic does a plug valve have over other common types of valves?
240. List the methods of measuring pipe and state facts needed when measuring pipe.

To determine the length each pipe is to be cut, you must understand the various methods of measuring threaded pipe. Among the different methods are end-to-end measurements, center-to-center measurements, and end-to-center measurements, as shown in figure 3-10. These measurements must be understood if pipe is to be cut to the correct lengths.

End-to-end measurement is exactly what the name implies. It is the full length of the pipe, including the threads. Center-to-center measurements are used when the pipe has a fitting screwed on both ends. This is a measurement from the center of the outlet on one end along the pipe to the center of the outlet on the other end. End-to-center measurements are used when a pipe has a fitting screwed on one end only. It is a measurement from one end of the pipe, including the threads, to the center of the outlet of the fitting on the other end.

Pipe Threads. Standard pipe threads are used for all pipes and fittings. Threads are identified by number per inch. Eight peaks or threads in an inch indicate there are eight threads per inch. The number of threads per inch is determined by pipe size. The normal length of the threaded portion of the pipe is also listed. However, a general rule is to thread enough pipe to expose at least two full thread revolutions beyond the die. The following are normal pipe and thread sizes.

SIZE OF PIPE	NUMBER OF THREADS PER INCH	TOTAL LENGTH OF THREADS ()
1/4 - 3/8	18	5/8"
1/2 - 3/4	14	13/16"
1 - 1/2	11/12	1"
2 1/2	8	19/16"

The method of measuring and the approximate thread lengths are the same for black iron pipe, which is used in a gas or steam supply system, as for iron or steel pipe.

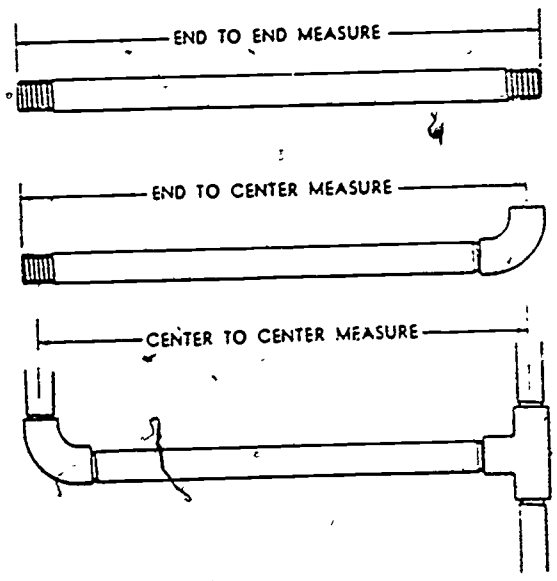


Figure 3-10. Determining pipe measurements.

Exercises (240):

1. Name the methods of measuring pipe.
2. How many threads are found on a 3/4-inch piece of pipe?
3. When would you use the center-to-center method of measurement?
4. How are threads identified?
5. What fact is determined by the size of pipe?

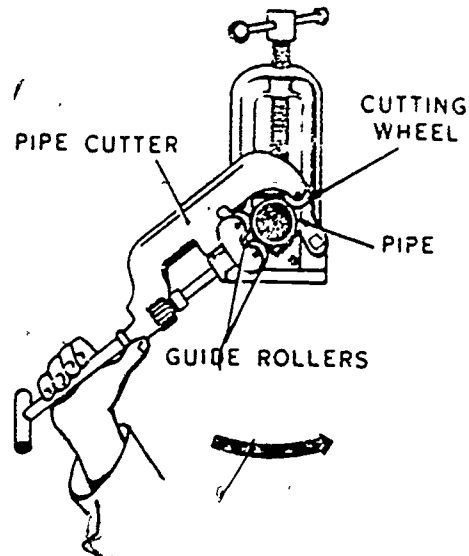


Figure 3-12. Cutting a pipe with a pipe cutter.

241. Explain the procedures used in measuring, cutting, and threading pipe.

Cutting Pipe by Hand. After the pipe has been measured and marked, it should be inserted into a pipe vise, where it is held for the cutting operation. Figure 3-11 shows a piece of pipe in a vise ready to be cut with a pipe cutter. To cut pipe with a pipe cutter, open the jaws of the cutter by turning the handle counterclockwise. Then place the pipe cutter around the pipe at the mark where the cut is to be made. One revolution must be made around the pipe to make a complete cutting mark before turning the handle clockwise again to cut the pipe deeper. If this is not done, the pipe cutter will make spiral marks around the pipe instead of marking one complete circle. Figure 3-12 shows a pipe

cutter ready to make the first turn on the pipe to be cut.

After at least one complete turn has been made, the handle of the pipe cutter can be turned one-fourth turn to take another "bite" on the pipe. These steps can be repeated until the pipe has been cut off. Figure 3-13 shows a cutaway of a piece of pipe and the result when using a pipe cutter. "A" shows how the cutter causes a burr to form within the pipe and "B" shows a cross section of the burr after the pipe has been cut off. This burr must be removed before the pipe is installed, since it hinders the flow of liquids and gases in a pipe.

Reaming Pipe by Hand. The burr is removed from the end of the pipe with a pipe reamer. This operation is accomplished by inserting the pipe reamer into the pipe while the pipe is still clamped in the vise. The handle on the reamer is rotated clockwise in short even strokes until the burr on the inside of the pipe has been completely removed. After a piece of pipe has been properly cut

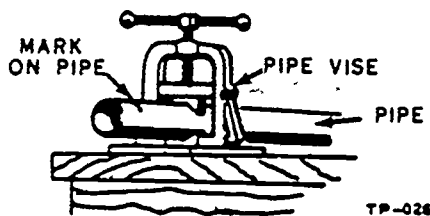


Figure 3-11. Pipe vise.

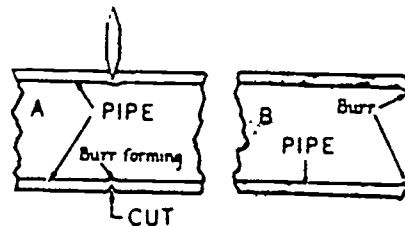


Figure 3-13. The results of cutting pipe with a pipe cutter.

and reamed, it can be threaded by hand or with powertools.

Threading Pipe by Hand. A stock and die set of the nonadjustable ratchet type may be used to cut threads on pipe by hand. The nonadjustable ratchet dies can be used to cut threads on pipe from 1/8 inch to two inches in diameter by changing to the correct size die.

Before threading a pipe, inspect the dies to see that they are sharp and free from nicks and wear. Next, insert the pipe into the vise, place the round guide end of the pipe die stock on the pipe and push the pipe dies against the pipe with the heel of the hand. Exert considerable pressure with the heel of the hand against the pipe die stock and take three or four short clockwise strokes, with the handle of the die stock, to start the thread cutting operation. After the dies have started, continue with clockwise strokes on the handle, with an even and steady pressure until approximately two threads project beyond the head of the die. **NOTE:** To cut clean threads for watertight and airtight joints, the pipe threading dies must be oiled after each two or three strokes with a good grade of lard or sulphur pipe thread cutting oil. The oil prevents overheating and chipping of the dies and marring of the threads.

When the proper number of threads are cut on the pipe, reverse the ratchet on the die stock for counterclockwise operation and make several short motions backward and

forward with the handles of the stock to loosen the burrs which are inside the dies. Continue to turn the handle of stock counterclockwise until the dies are free of the threads. **CAUTION:** Many mechanics have a habit of spinning the pipe die stock rapidly to speed the removal of the dies from the pipe. While this may not be injurious to the pipe thread, extreme care must be exercised when spinning the stock to prevent it from striking the legs of the vise or causing an injury to the mechanic.

Cutting, Reaming, and Threading Pipe with Power Tools. To be able to cut, ream, and thread pipe with power tools is a great time saver. It can be very dangerous, though, if the operation is not properly performed. There are many different types of pipe threading machines. Each is designed to accomplish the same purpose when properly used. The most common types of threading machines are the power-driven bench threader, power-driven vise stand, and geared-type threader.

A bench pipe threading machine like the one shown in 3-14 is usually found in every heating shop. The diagram shows the working parts of such a machine. This machine is designed to cut and ream the pipe as well as thread it.

Another type of cutting machine which you will probably use is a portable power-driven vise stand. (See fig. 3-15). This machine is so designed that it turns the pipe

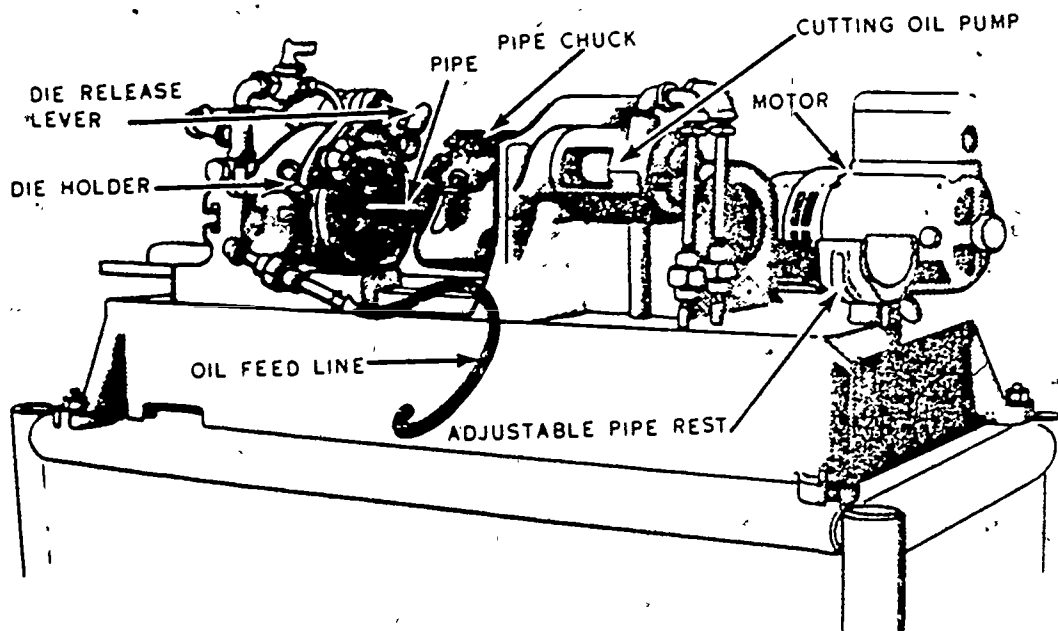


Figure 3-14. Power-driven bench pipe threading machine.

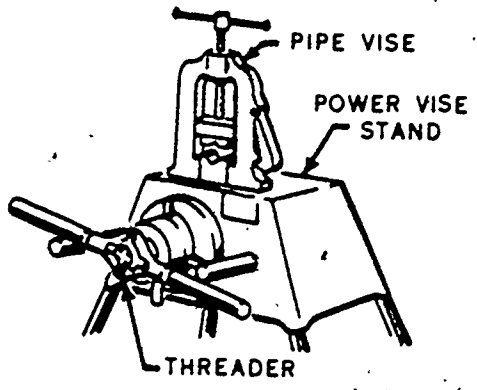


Figure 3-15: A power-driven vise stand.

to be cut or threaded while the threader is resting on the arms of the machine. The pipe to be cut, reamed, and threaded is inserted in a chuck in the same manner as when using the power threading machine mentioned previously. CAUTION: When using this machine, be sure to rest the handles of the cutter, reamer, and threaders against the bars. Many mechanics have injured themselves by attempting to hold the handles of these units by hand. Remember, if you let go of the handles, they are apt to strike you or catch in your clothes and pull you off your feet before the machine can be stopped.

Another method used to cut threads on a pipe larger than two inches in diameter is with a combination geared-type threader and a power vise stand. The geared-type threader is turned by the power from the vise stand through a flexible shaft, or a shaft with two universal joints. NOTE: Cutting, reaming, and threading pipe with power machinery is a common operation which can be very dangerous unless the rules of safety are observed. Most mechanics have cut, reamed, and threaded pipe with power machines so many times that it has become a routine job with them. Performing routine work such as this is where most mechanics suffer their crippling injuries. They may cut their hands, drop pipe on their feet, or get their clothes caught in a moving part of the machine. Remember to keep your mind on your work when working with power machinery.

Once a heating mechanic has mastered the tasks of measuring, cutting, reaming, and threading pipe, his next step is to know how to connect pipe and pipe fittings.

It is important that the mechanic have a good knowledge of pipefitting. He must study his blueprints and job plans so that the correct fittings are procured for the job. The

loss of time and material is avoided when the correct fittings are procured from the very first. Always prepare a checklist to make sure that the proper tools and equipment are on hand. Also have the plans available for quick reference.

Threaded pipe joints are commonly used when wrought iron and steel pipe fittings are installed. This method of joining the pipe involves connecting the threaded male and female ends together.

To obtain a tightly threaded joint, it is important that the threads be clean and in good condition. The threads must be checked very carefully if the pipe or fittings have been exposed to the weather or "banged" around. It may be necessary to run a tap into or a die over the threads to straighten any that are damaged.

Cleaning the pipe ends with a wire brush is a good start toward making the joint. After the pipe is secured in a vise, the thread lubricant is smeared on the male threads.

The fitting is turned on by hand as far as it will go; then it is tightened with a pipe wrench. A "hickey" (an oversized wrench) or too much pull should not be used. Not all of the male threads need to go into the joint. When all the threads are used, the wedging action of the tapered thread can cause the fittings to split.

Two pipe wrenches should always be used when wrought iron or steel fittings are being installed. This will allow for more pressure to be applied to tighten the joint. It is important that the pipe or fitting to which a new pipe or fitting is being installed does not turn. Figure 3-16 shows the correct way to apply wrenches. In figure 3-16, the pipe wrench (A) shows that it is used for holding the pipe to keep it from turning while the fitting is being tightened. Figure 3-16 shows another pipe being connected to the coupling. Therefore, the coupling must be held to assure that the next pipe is connected securely. Two or more fittings should never be connected at the same time.

Experience is the best teacher when it comes to determining how tight a joint should be. Usually there will be two or three unused threads on a properly threaded pipe. If the threads have been made correctly, the joint will be tight enough to withstand the pressure for which the pipe and fittings are made.

Exercises (241):

1. From the following information, identify the material used and explain the procedures used in installing a length of pipe.

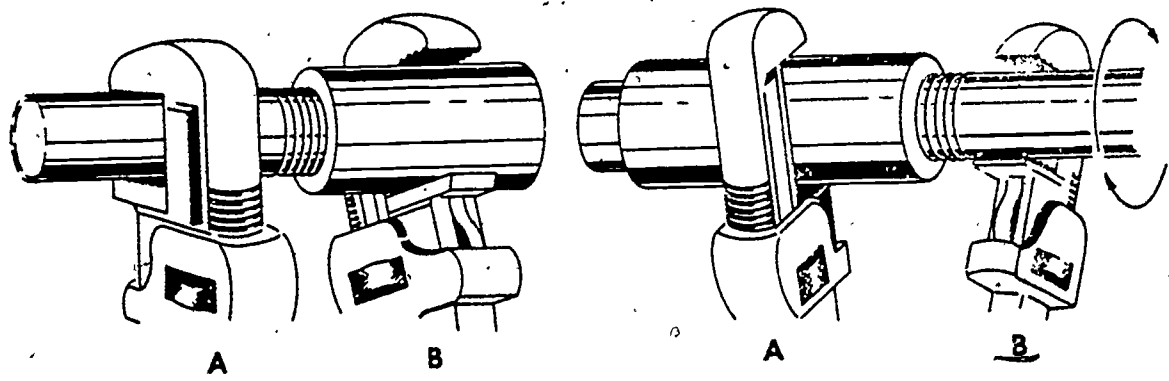


Figure 3-16. Using two wrenches.

- a. 24 inches from valve to gas control.
- b. Valve size - 1/2 inch—gas control - 1/2 inch.

2. What tasks are accomplished in threading a 2-inch piece of pipe and a 1-inch piece of pipe, one after the other? Why?
3. What safety precautions would you deem necessary in operating a power-driven threader?
4. In cutting a piece of pipe, you find that the cutter has made a double cut. What is the most likely cause?
5. In inspecting a length of recently threaded pipe, you find rough cut threads. What would be the most probable cause?

3-2. Fundamentals of Copper Tubing

Copper tubing has become very popular and is quite rapidly replacing iron pipe in modern heating installations. Due to its light weight, the tubing is easily transported and can be quickly installed. The joints are quick and easy to make and are as permanent as the tubing itself. All pipes do not offer the same resistance to the flow of liquid going through them nor are they subject to the same amount of corrosion. Copper tubing has the least

resistance to liquid flow, has a high resistance to corrosion, and will last longer than steel or iron pipe. Since the flow of liquids is comparatively free, copper tubing can be smaller than iron pipe and still deliver an equal amount of liquid to the point of discharge.

Copper pipe is also recommended for a wide range of domestic, commercial, industrial, and special-purpose installations. They are economical because of their long life, their low friction loss to liquid flow, and their high tensile strength to withstand pressure or stress. They are also easy to joint together by using flared joints or by soft soldering. Despite these advantages, the initial cost is high and for that reason it is not used for general purposes.

242. Specify copper tubing characteristics.

Types of Copper Tubing and Pipe. There are four main types of copper tubing and pipe: K, L, M, and DWV. The classification is determined by wall thickness. Copper pipe or tubing is measured by outside diameter (OD).

Type K. A green color band, in addition to stencil on the pipe surface, identifies the pipe as type K. It is recommended for underground installation and high pressure. Type K is available in a variety of sizes ranging from 1/4" to 12" in diameter and has the thickest wall of the four types.

Type L. A blue band identifies this copper pipe. It has a medium wall thickness and is recommended for interior use. Type L is also available in 1/4" to 12" diameters.

Type M. Type M has a light wall thickness and is used in low-pressure installations. It is color coded red in the copper color code system. Type M is available in sizes 1/4" through 6" diameter.

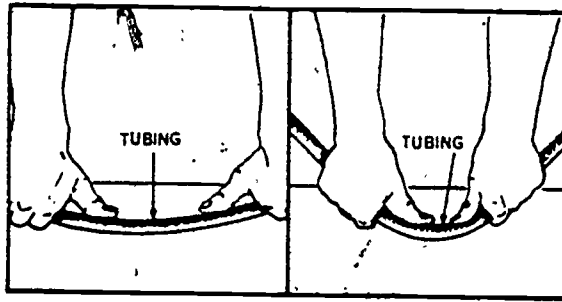
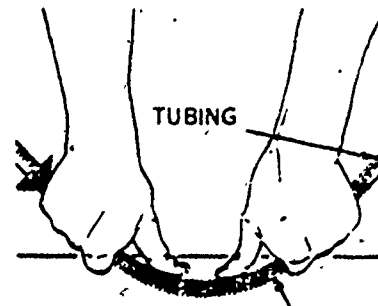


Figure 3-17. Bending tubing filled with sand.



SPRING TUBE BENDER

Figure 3-19. Bending tubing with a spring.

Type DWV. The thinnest wall of all types of copper tubing and pipes is classified as DWV. It is used in nonpressure applications and is distinguished by a yellow band. This material is available in sizes 1/4" to 6" in diameter.

Copper pipe and tubing may be obtained either in hand drawn (hard temper) or annealed (soft temper).

The hard drawn copper (K, L, and M) is available in 20-foot lengths. Annealed copper, including K, L, and DWV, is available in 50-foot rolls.

Bending Copper Tubing. Copper tubing used for liquid lines is soft enough to be formed into desired bends where it is necessary to change direction of a line. If care is taken copper tubing may be bent by hand, but the slightest excess pressure at one particular point will result in a flattened or kinked tube, rendering it useless. Hard tubing requires annealing (softening) of the portions to be bent. This can be done by heating the portion of tubing to a dull-red, and allowing the heated portion to cool slowly.

Kinking is prevented when bending soft copper tubing by filling the tubing with sand. The sand in the tubing keeps the walls from collapsing during the bending process. (See fig. 3-17).

Another method used in bending soft copper tubing is the use of a bending block of correct size. The block is mounted on a table or other solid structure with a metal loop attached to the edge of the table. The end of the tube is inserted in the loop, and using both hands, the tubing is gradually formed over the contour of the block. (See fig. 3-18).

Still another method that is used by the heating specialist to bend soft copper tubing without buckling it so easily is to place the correct size flexible bending spring over the tubing and gradually form it with the thumbs and at the same time pressing the tubing

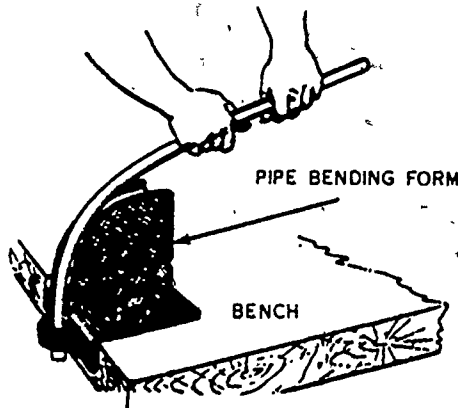


Figure 3-18. Bending tubing over block.

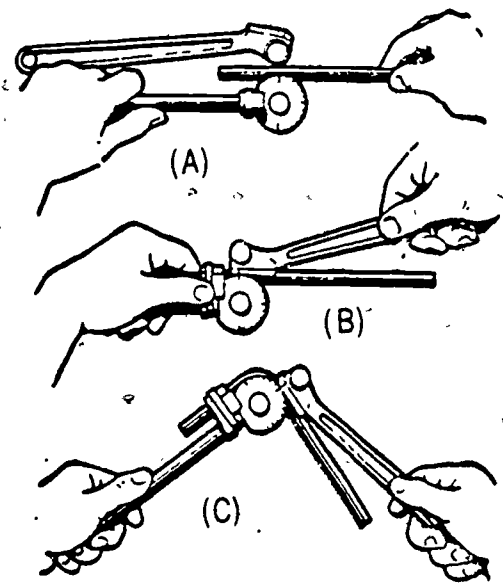


Figure 3-20. Bending copper tubing.

143

against a table or solid flat structure. (See fig. 3-19.)

Tube benders are considered the most practical way to bend copper tubing. They are made in many sizes and designs. Figure 3-20 illustrates a tube bender and the steps used in bending tubing. When placing the tube in the bender, raise the right handle of the bender as far as it will go so that it rests in a horizontal position, as shown. Raise the clip and drop the tube in the space between the handle slide block and the bending form. Drop clip over tube and turn handle slide bar about its pin and press to the right. Note that ZERO mark on bending form will line up with the mark on the slide bar. Proceed to bend to the desired angle.

You can bend tubing to any angle up to 180° with this tube bender. To remove the bent tube from the bender, lift the handle slide bar back to its horizontal position, raise the clip, and remove tube from bender.

Exercises (242):

1. What is the difference between copper tubing of the yellow band and green band?
2. Cite characteristics of copper tubing which differ from those of most iron pipe?
3. In checking a fabricated tubing system, you find that there are many flattened places in the tubing. What is the most probable cause?
4. What does a blue color band represent in copper pipe?

243. Identify the types of copper tubing fittings.

There are many types of fittings available for use with copper tubing. Nearly all fittings in their various sizes are stocked by the heating shop. These fittings include valves and cocks, adapters, couplings, tees, elbows, and reducers. Many of the fittings are illustrated in figure 3-21. Copper fittings are of the flare type, sweat type, and compression type. Many times a heating man has to make a

connection between iron or steel pipe and copper, and adapters are used for this purpose. One end of an adapter has standard pipe threads (male or female), and the other end has copper threads.

Exercises (243):

1. What type of copper tubing fittings will you generally find in a heating shop?
2. To change the direction, using copper tubing, which means would most likely be used?
- 3: What are adapters used for?

244. Describe the process of cutting copper tubing with a tubing cutter.

Copper tubing is prepared for use by first determining the measurements necessary for the particular installation. When the length is determined, the tubing may be cut with a tube cutter or a hacksaw.

The tube cutter for copper is similar to the pipe cutter for iron pipe, except that it is smaller. To cut tubing with a cutter, mark the tubing where it is to be cut and install the cutter on the tube so that the cutter wheel is over the mark. Now turn the tube cutter adjustment clockwise to force the cutter wheel against the tubing. Revolve the cutter around the tubing. Continue revolving the cutter, turning the knob slightly after each revolution, until the tubing is cut through and separates.

Copper tubing may also be cut with a hacksaw if a tube cutter is not available. Select a hacksaw blade with fine teeth to do the cutting. Be sure you cut the tubing square. A miter box should be used to insure a square cut.

After the tubing is cut with a tube cutter, the burr inside the tube must be removed. This is done with a tube reamer. Place the point of the reamer into the end of the tubing, and turn the reamer alternately in opposite directions until the burr is removed. Do not use tubing that has not been reamed, because the burrs will restrict the flow of liquids and gases through the pipe.

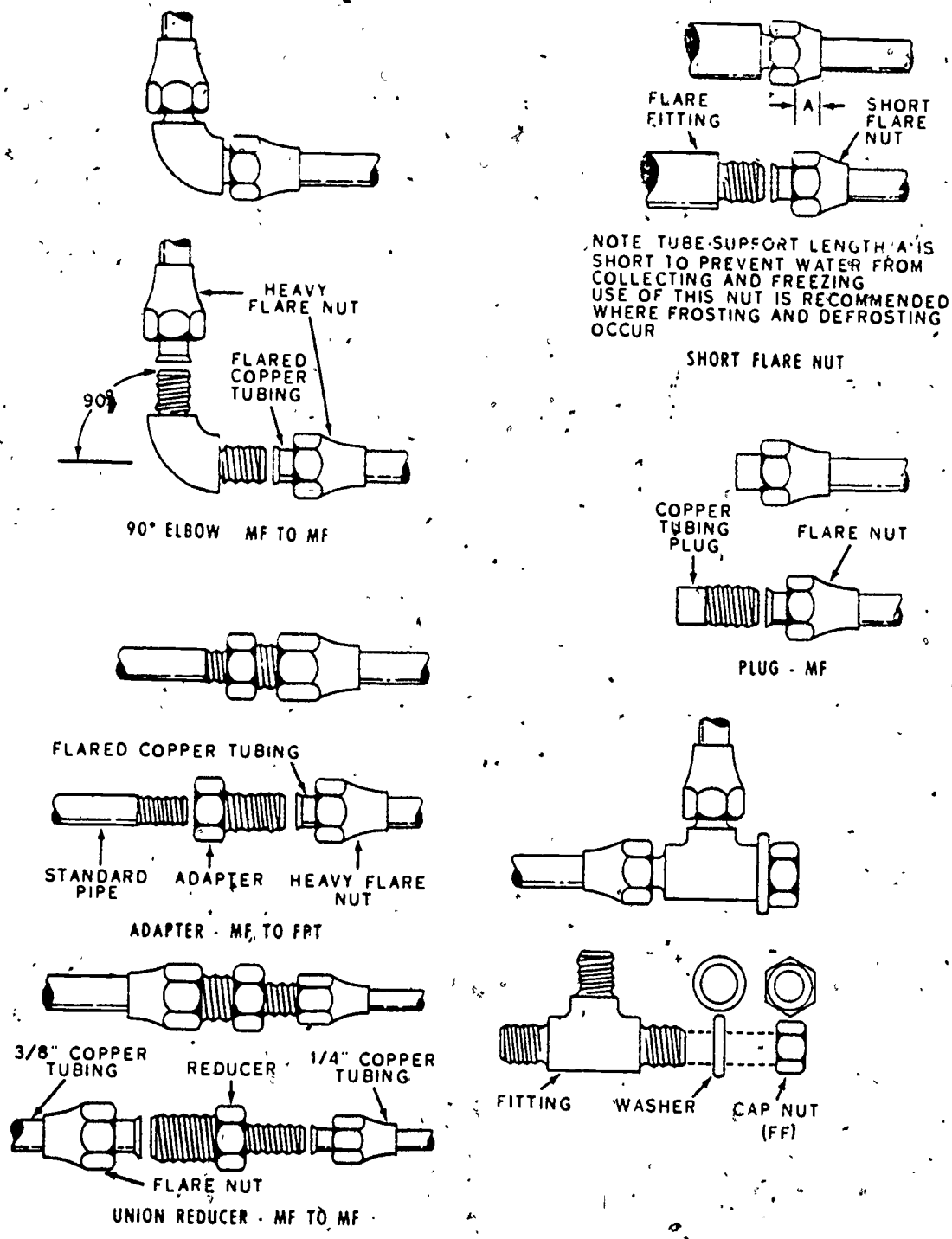


Figure 3-21. Flare fittings.

Exercises (244):

1. What methods are used to cut copper tubing?
2. Describe the process of cutting copper tubing with a tubing cutter.

3-3. Soldering

The heating specialist many times finds himself in a situation where two sections of copper tubing must be joined and there is not enough room to employ a flaring tool. This situation is where the soldering method of joining copper tubing should be used.

245. Name the types of solder.

Solder is an alloy or metal used, when melted, to join other metals. Soldering alloys may be classified as hard solder if they melt above a red heat, and soft solder when they melt at lower temperatures. These are also called brazing solder and tin solder. The melting point of solder should be lower than that of the metal on which it is used.

A well-liked soft solder that is used on most soldering projects by the heating specialists is known as half and half, made with equal weights of tin and lead (50/50). This solder melts at approximately 360° F. and is free-flowing around 415° F.

Exercises (245):

1. Which type of solder is most commonly used by the heating specialist?
2. What alloys make up the contents of soft solder 50/50?
3. What is another term for hard solder?
4. Name the common types of solder.

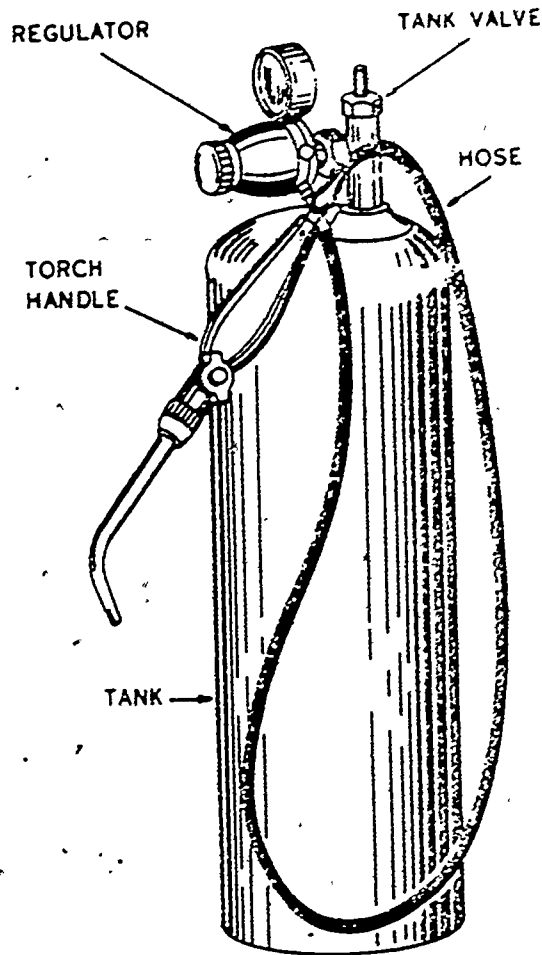


Figure 3-22. Air-acetylene torch.

246. Identify methods of soldering.

A high-temperature concentrated flame that will quickly bring the fitting to the melting point of solder is the only heat that is necessary for "sweating" fittings on copper tubing. If it is at all possible, an air-acetylene torch, like the one illustrated in figure 3-22, should be used. This type of torch consists of a small portable cylinder of acetylene gas, a regulator, hose and torch. The air-acetylene torch is very efficient and produces a good flame for soldering. The acetylene gas mixes with the atmospheric air to support combustion and produces a flame up to 4000° F.

Another method is the common propane torch. This will also provide enough heat to effectively melt solder.

Exercises (246):

1. What are the two most common methods of melting solder used by the heating man?

146

247. Explain the swaging process.

Many times there are instances where solder fittings are not readily available. So, in order to connect copper tubing together, the process of swaging comes in handy. Swaging is a means of shaping one section of copper tubing to fit or correspond to the other section. A swage block similar to a flare block is used to hold the copper section rigid. A swage, which comes in various sizes to correspond to tubing sizes, is then inserted into the tubing end. This is then struck with a hammer or mallet until the swage is forced down to shape the copper tubing end to a correct size. The correct size and shape are reached when one section of tubing will fit snugly (but not tightly) into the swaged end. Soldering procedures can then begin.

A precautionary method to observe when striking the swage with a hammer is to always rotate the swage so that it will not become lodged in the copper tubing. This could cause a poor connection.

Exercises (247):

1. When is the swaging process used by the heating man?
2. What does the swaging process do?
3. After swaging has been accomplished, what method is used to permanently join the copper tubing?

248. Indicate fundamentals of soldering heating lines and fittings.

Sweat soldering is a method of joining two metals together by allowing molten solder to run between the tubing and fittings. The law of capillary attraction governs the force responsible for the bonding in solder joints. The tubing must be (1) cut to length, (2) reamed, (3) cleaned, and (4) bent, if necessary, before you are ready to solder the joint.

The process of cutting copper tubing was explained in Learning Objective 244. We will continue with the cleaning process.

Your preparation of joints for soft soldering must be thorough. Metal surfaces

must be perfectly clean at the joint to obtain a good bond between the base metal and the solder. You must remove all dirt, grease, oil, paint, etc., and must make the metal bright. Clean the tubing with a wire brush, file, emery cloth, or steel wool. You may also use chemical cleaners. Make sure that the parts to be joined fit together very closely. The only additional thing that you need to make the joint is a thin film of free-flowing solder.

When the fitting and tubing are ready to be joined, apply heat evenly around the fitting. Do this by moving the flame back and forth. This procedure also keeps you from overheating the tube and fitting. Why is this important? Because if the connection is overheated, the flux may burn out, causing oxidation, and the solder will not spread evenly.

Also, of course, an overheated joint causes the solder to seep through the joint and flow away. You should therefore occasionally test the heat by touching the fitting with solder where the tubing and fitting join. Normally, thick wall fittings require more heat than thin wall fittings. When the tube and fitting melt the solder, the sweating may begin.

As soon as the connection is hot enough to melt the solder, remove the flame and apply the solder to the edge of the fitting where it comes into contact with the tube. Solder, when confined between two surfaces, will run uphill by capillary attraction. Joints can be made in any position.

The amount of solder required for a connection depends upon the diameter of the tube to be sweated. For instance, $\frac{1}{4}$ inch of solder should be sufficient to solder a joint for $\frac{1}{4}$ -inch tubing, $\frac{1}{2}$ inch of solder for $\frac{1}{2}$ -inch tubing, etc. (The amounts suggested are based on solder with a diameter of $\frac{1}{8}$ inch.)

When a line of solder shows up around the fitting—that is, a bead of solder appears in the groove at the end of the fitting—the joint has all the solder it will take. When you apply solder to a tee, feed solder from both ends of the fitting. Reheat the fitting slightly to help the solder penetrate into the metal. Remove the flame and continue to feed the solder to make sure the joint is filled.

Allow the joint to cool for a short while. A rag or wad of waste, saturated with water, will hasten this cooling. When you cool male and female adapters, allow more time for the solder to set, because these fittings are heavier, they hold heat longer, and they do not cool as quickly.

When unsoldering a tube from a fitting on which other soldered connections are to be left intact, make sure that you will not melt

the solder in the other connections. Keep the connections that are to be left intact cool by applying damp cloths to them. You may also use damp cloths to protect valves and other units from the intense heat. Make a shield from a sheet of asbestos paper and slip it over the tubing to protect combustible materials or a flammable wall while you are soldering.

Exercises (248):

1. Solder runs uphill by what method?
2. What procedure hastens the cooling of solder?
3. A soldered joint that leaks is probably caused by what discrepancy?
4. How much solder would be needed in soldering a section of 2-inch tubing?
5. What may be the outcome to a soldered joint if a torch is held on one spot too long?

3-4. Fabrication of Systems

Knowledge of fittings, solder, copper tubing, and pipe is of great importance to the heating man; but without the knowledge of how to make connections, this knowledge has no meaning. It is important to know what kind of fittings to use at various times and how to use them.

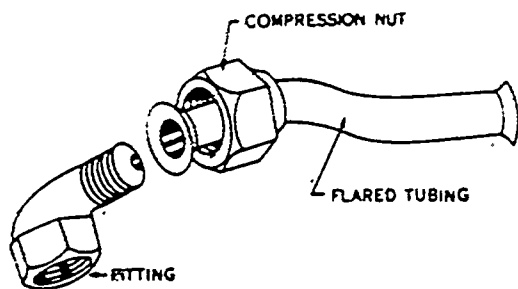


Figure 3-23. Flared tubing, compression nut, and fitting.

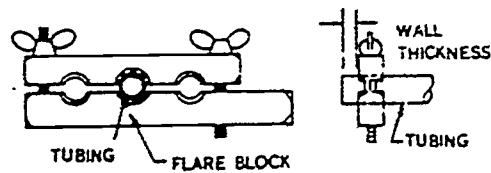


Figure 3-24. Placing tubing in a flaring block.

249. Identify the fundamentals of flaring.

One easy and satisfactory method of joining copper tubing is to flare the ends of the tubing and press the flared end against the tapered surface on the fitting. Then screw the compression nut up tight over the end of the fitting, as shown in figure 3-23.

An advantage of this type of connection is that it may be easily disassembled when it becomes necessary to make repairs. To disassemble this connection, select the correct size of wrench, unscrew the compression nut that makes up the compression-type connection, and separate the fittings.

When you make a flare on copper tubing, take every precaution to produce an airtight and watertight joint. First, measure and cut the tubing to the proper length with a tube cutter or hacksaw. Then remove the burr within the pipe and clean the surface to be flared with emery cloth or steel wool. Copper tubing is flared with a flare block.

Before you make a flare on a piece of tubing, slip the compression nut on the tubing and insert the end of the tubing into the correct-size hole in the flaring block. Then extend the end of the tubing above the face of the block approximately the wall thickness of the tubing, as shown in figure 3-24. This procedure allows enough tubing to spread over the taper of the fitting.

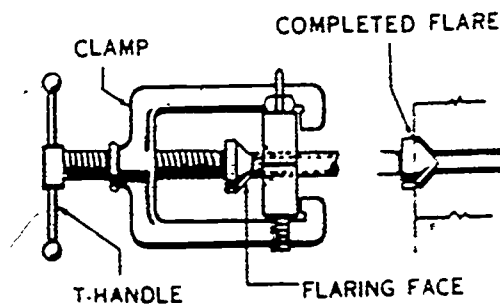


Figure 3-25. Positioning the clamp and making the flare.

Now, attach the clamp to the flare block, and center the flaring face over the end of the tubing, as shown in figure 3-25. Force the flaring face against the flaring block by rotating the handle on the clamp clockwise. This causes the end of the tubing to expand just enough to fit into the compression nut and over the end of the fitting.

When you make the flare on the tubing, check and be sure that you do not expand the flare larger than the inside of the compression nut. The flare should slip freely into the compression nut when it has been properly formed.

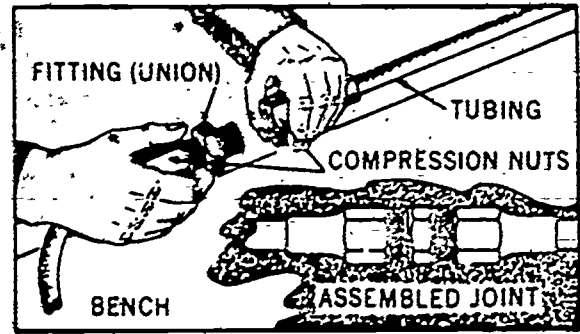


Figure 3-26. Assembly of a flared joint.

Exercises (249):

1. What would a leaky flare fitting indicate?
2. Installing copper tubing to a fuel pump would take which type of joint? Why?
3. What advantage does a flared joint have over a soldered joint?
4. What would be the result if the end of a piece of tubing were expanded oversize?
5. What would be the result if it were not expanded enough?

making a watertight and airtight joint. When these joints are properly tightened with two wrenches, they will withstand a pressure of 3000 pounds per square inch.

Wrenches that are used to tighten these joints should fit snugly to avoid damaging the connection. Do not use a tool that will mar or scar either the tubing or fittings. During the tightening process, be careful to avoid stripping the threads.

Use two open-end wrenches when tightening or loosening these fittings to avoid twisting the tubing. Do not use excessive pressure when tightening these connections because copper and brass fittings are soft, and the metals contain a certain amount of lubricant of their own which seals them together with a minimum amount of pressure.

Exercise (250):

1. Cite the procedures that are necessary in fabricating a copper tubing system.

250. Cite the procedures for fabricating a copper tubing system.

After the tubing has been properly flared, your assembly of the joint is simple. To make the joint requires a fitting that is threaded and formed on both ends to receive the flare of the tubing.

Some fittings are designed with only one end to receive the flare. Others have a regular tapered pipe thread to fit the threads in a casting or pipe. When the proper fitting is obtained, place the flare against the fitting, as shown in figure 3-26. Now slip the compression nut against the flare and screw it onto the fitting. This operation squeezes the flare of the pipe between the fitting and compression nut, as shown in figure 3-27,

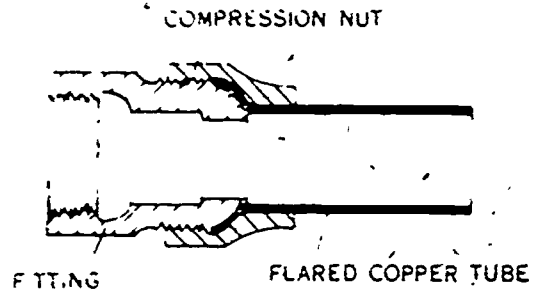


Figure 3-27. Cross-section of a flared joint.

Principles of Heating

IT IS NOT KNOWN just exactly when man discovered fire, but there is no doubt that fire is one of the greatest gifts to mankind. The need to control and apply fire was apparent from the very first. Imagine what living conditions were during the cave-dwelling period. Unless a natural flue or some other method of ventilation existed as a result of the cave, the smoke from fires during cold weather must have created almost unbearable conditions, leaving the inhabitants the choice of either freezing or being asphyxiated.

Long after man had advanced to the stage of housebuilding, heating methods had not improved to a very great degree. For centuries (and occasionally, even today) fires for heating and lighting were contained in braziers or confined to an unused corner of a room. The smoke was supposed to escape through a hole left in the roof of the building during construction. Of course, considerable amounts of rain and snow entered the room during bad weather. During the twelfth century, however, the people in the northern part of Europe started using crude fireplaces and flues to replace the brazier and hole-in-the-roof method of heating. Some of these rudimentary heating systems still exist in France.

In the thirteenth and fourteenth centuries, the round hollow stone chimneys began to be used. At the end of the fifteenth century, people were using a number of fireplaces in their homes and grouping the chimneys together in a vertical, rectangular mass of masonry with decorative effect. By the end of the Italian Renaissance period, chimneys were in common use.

During colonial days in America, the fireplace chimneys were a large masonry mass projected through the center of the roof or were an important feature of the gable end walls. This general trend is often followed in architecture today. Central heating, where fires are required 5 or 6 months of the year, makes the chimney an important feature of a

heating plant. There are heating installations, however, which do not make use of the masonry chimney and have substituted an inconspicuous metal smoke pipe. Other types of heating, such as electrical heating, require no chimney.

4-1. Theory of Heat Transfer and Measurement

Knowledge of the theory of heat and heat measurement and transfer will be useful to you in understanding how heat is produced and how it gets from your heating plant to the space you are going to heat. Heat is one of the prime necessities of life. It is as essential as food, clothing, and shelter. You can have a very good shelter, but you still need heat to be comfortable.

Heat is a form of energy that is known for its effect. Heat can be produced or generated by the combustion of fuels, by friction, by chemical action, and by the resistance offered to the flow of electricity in a circuit. However, the particular form of generated heat with which the heating specialist will be dealing is produced by combustion. This is heat obtained by burning common types of fuels such as coal, oil, and gas.

251. Identify the methods of heat transfer and tell how heat is transferred through solid material.

The transfer of heat is a problem to consider after the heat has been produced by the burning of a fuel. It must be moved to the space where it is to be used. Heat always flows from a warmer to a cooler substance; consequently, there must be a temperature difference before heat will flow. Naturally, the greater the difference in temperature, the faster the heat flow. Two objects that have different temperatures, when placed together, will tend to equalize their temperatures. Heat travels in heating systems from one place to

another by three different methods. All three of these methods are used in most heating systems; they are discussed in the paragraphs that follow.

Conduction. Conduction is the flow of heat from one part of a substance to another part of the same substance, or from one substance to another when they are in direct contact.

When one end of a stove poker is held in a flame, the other end will soon be too hot to hold. This indicates that the heat is being conducted, or transferred, from one end of the poker to the other end. Such a transfer of heat is called conduction. Conduction is used to transfer heat through the walls of a stove, furnace, or radiator so that the warmth can be used for heating. If a piece of wood had been used, as an example, instead of the poker, the end of the wood away from the fire would have remained cool. This shows that some materials do not conduct heat as well as others. Those materials which offer considerable resistance to the flow of heat are referred to as insulators, or poor conductors.

Convection. Convection is the transfer of heat by means of mediums such as water, air, and steam. When air is heated, it expands, becomes lighter in weight, and rises. The cooler air, which is heavier, then flows in to replace the warm air. Thus, a convection current is set up. Water, when heated, acts in the same way as air. The water next to the heating surface becomes warmer, lighter, and rises. This action allows the cooler water to flow in next to the heating surface and become heated. Convection is a very important factor to be considered in a heating system. It is this force, developed by heating the medium, that circulates the heating medium to the space to be heated.

Radiation. Radiation is the transfer of heat through space. When a hand is held in front of a stove, it is quickly warmed by means of radiation. In this same manner, the earth receives its heat from the sun.

Radiated heat is transferred by heat waves, similar to radio waves. Heat waves do not warm the air through which they pass, but they must be absorbed by some substance to produce heat. For example, when you stand in the shade of a tree, you feel cool, because the leaves and limbs are absorbing the heat waves before they reach you.

When heat waves strike an object, some are reflected, some may pass through, and the rest are absorbed by the object. Polished metals are the best reflectors known; therefore, they are poor absorbers of heat. A poor absorber is also a good radiator. Rough metal absorbs heat more readily than a highly

polished metal, and it also loses heat faster by radiation.

The color of a substance also affects its absorbing power. A black surface absorbs heat faster than a white one. That is why light-colored clothes are cooler in summer than dark-colored ones.

Exercises (251):

1. Heat may be transferred from a body to another body which is at a lower temperature by what methods?
2. On what condition is conduction dependent?
3. In what status of matter can heat be transmitted by convection?
4. How would heat be transmitted through solids such as steel?

252. Specify the methods of measurement of heat.

To operate a heating unit efficiently, you must be familiar with the measurement of heat.

The unit of measurement for a given quantity of heat is the British thermal unit, abbreviated and commonly known as Btu. One Btu is the amount of heat needed to change the temperature of 1 pound of pure water 1° Fahrenheit at sea level. If one Btu is added to 1 pound of water at 50° F., the temperature of that pound of water will be raised to 51° F.

Measurements of temperature and pressure, which are obtained continuously, are very important factors in the operation of a heating plant. The degree of correctness of these measurements directly affects the safety, efficiency, and reliability of operation of the heating plant. Although heat and temperature have a direct relationship, there is also a distinction between them. For example, a burning match develops a much higher temperature than a steam radiator, but the match does not give off enough heat to

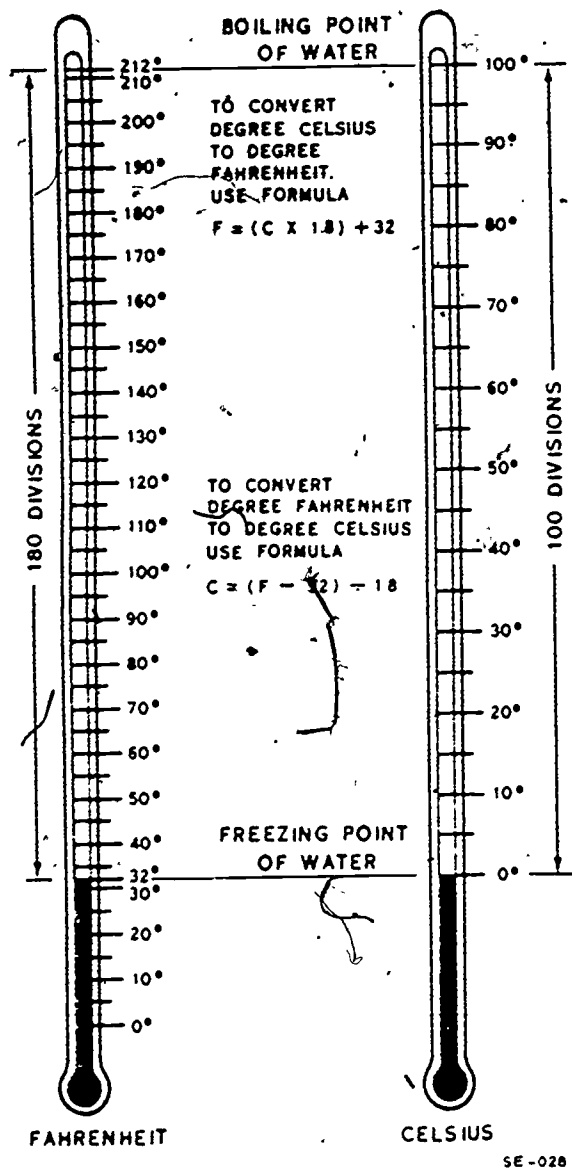


Figure 4-1. Comparison of Fahrenheit and Celsius thermometers.

thermometer is the standard used primarily in English-speaking countries.

The thermometer measures the degree of sensible heat of different bodies. The thermometer can make a comparison only between the temperature of a body and some definitely known temperature such as the melting point of ice or the boiling point of water. Figure 4-1 shows a comparison of the scales of Fahrenheit and Celsius thermometers. It also shows the markings of the freezing and boiling points of pure water at sea level. The range of the Fahrenheit thermometer between the freezing point and the boiling point is 180° (32° to 212° = 180°). On the Celsius thermometer, the range is 100° (0° to 100° = 100°) from the freezing point to the boiling point.

We should stop and explain the term Celsius. Anders Celsius, in the year 1742, devised a measurement scale based on the centesimal scale (relating to division into hundredths), commonly called centigrade.

In 1949, the US National Bureau of Standards, in order to honor Anders Celsius, renamed the centigrade scale to Celsius. This term will be phased into usage as new books and literature are published.

Exercises (252):

1. What is the British thermal unit?
2. The range of the Fahrenheit thermometer between the freezing point and the boiling point is how many degrees?
3. Give an example of a distinction between heat and temperature.

warm a room. Another example tells us that 10 pounds of water at 80° F. will melt more ice in a given length of time than 1 pound of water at 100° F. The former has more heat, but the latter has a higher temperature. Temperature is the measurement of heat intensity in degrees Fahrenheit or Celsius. Therefore, temperature measurements can be made by using a glass thermometer which is calibrated either in degrees Fahrenheit (F) or degrees Celsius (C). The generally accepted way of stating measurements of temperature is in degrees Fahrenheit. The Fahrenheit

253. Change a prescribed Fahrenheit measurement reading to a Celsius measurement reading and a Celsius to a Fahrenheit reading.

To convert Fahrenheit readings to Celsius readings, it is necessary to subtract 32° from the Fahrenheit temperature reading and multiply the remainder by .556, or $\frac{5}{9}$. To change Celsius readings to Fahrenheit

readings, multiply the Celsius temperature reading by 1.8, or $\frac{9}{5}$, and add 32°.

- Examples: 122° is what degree Celsius?
 C = (122 - 32) multiplied by .556
 C = 90 multiplied by .556
 C = 50°
- 50° C. is what degree Fahrenheit?
 F = (50 X 1.8) + 32
 F = 90 + 32
 F = 122°

Refer to learning objective 252 for more information on measurements of heat.

Exercises (253):

1. Convert 180° F. to a Celsius reading.
2. Convert 80° Celsius reading to a Fahrenheit reading.

254. Explain how to determine total heat and define the terms "sensible" and "latent" heat.

Heat is a form of energy known for its

effects. There is only one type of heat. However, the effects of heat may be used to bring about different changes in a substance. The effects of heat that you should be familiar with are sensible and latent heat. Sensible heat is indicated by the sense of feeling and it is the heat which can be measured by a thermometer. An example of sensible heat is presented by placing a small vessel of cold water over a gas flame and putting a thermometer in the water. Upon observation, you note that the thermometer indicates a rise in temperature. Also, upon placing your finger in the water several times, you feel (or sense) the change in temperature that has taken place.

Latent heat is the amount of heat required to change the state of a substance without a measurable change in temperature. Latent heat is further clarified by the knowledge that all substances above absolute zero contain heat. There is heat even in ice, and its melting point is fixed at 32° F. Because of a fundamental law of nature, when ice at 32° F. melts into water at 32° F., a change of state takes place. It is that the ice (solid) has turned into water (liquid). A certain amount of heat is required during this change of state. This heat is known as the latent heat of fusion. When 1 pound of ice changes to water, 144 Btu's are required, and an additional 180

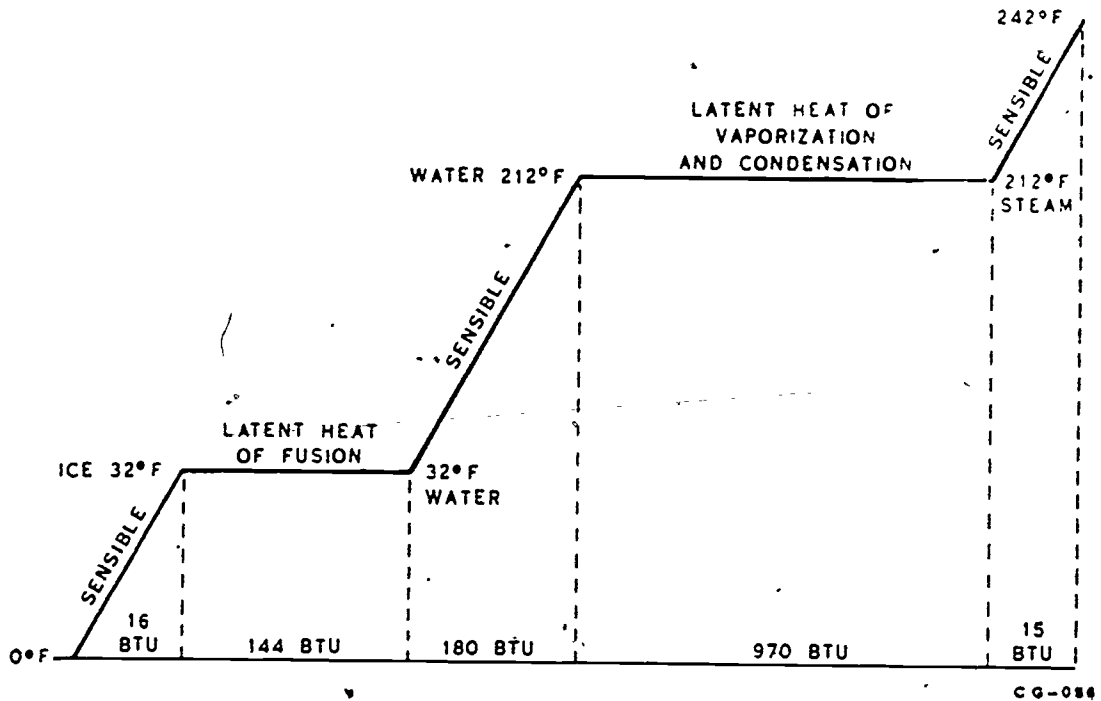


Figure 4-2. Sensible and latent heat.

Btu's are required to further raise the temperature of the water to 212° F., the boiling point at sea level.

To again change the state of this 1 pound of water (once ice) at 212° F. to steam, another 970 Btu's are required. This additional heat is known as the latent heat of vaporization. (See fig. 4-2.) Heat indicates the quantity of units of heat (Btu) in a substance, whereas temperature indicates the intensity of heat in degrees.

There are other terms of heat that you will encounter as a heating specialist. These are specific heat, super heat, and total heat. Specific heat is the ratio between the quantity of heat required to raise the temperature of 1 pound of any substance 1° F. and the amount of heat required to raise the temperature of 1 pound of pure water 1° F. Super heat is the amount of heat added to a substance above its boiling point. Total heat is sensible heat plus latent heat.

We previously mentioned absolute zero. But, what is absolute zero? Scientists have arbitrarily determined that when the temperature of a substance has been reduced to 460° below zero F. (-460° F.) practically all the heat has been removed from the substance. At this point the molecules cease to have motion. This temperature is known as absolute zero, and it is about the lowest temperature obtainable. Heat is said to be present in all substances when the temperature is above absolute zero.

Exercises (254):

1. Explain the fact that there is heat in ice.
2. When you have 90 Btu's of sensible heat and 70 Btu's of latent heat, how do you find the total heat?
3. Define the term sensible heat.
4. Define the term latent heat.
5. Explain why is absolute zero considered to be 460° F.

255. Explain the relationship between pressure, temperature, and volume.

The relationship between pressure, temperature and volume may be summarized as follows:

When temperature is held constant, increasing the pressure on a gas causes a proportional decrease in volume. Increasing the pressure causes a proportional increase in volume.

When pressure is held constant, increasing the temperature of a gas causes a proportional increase in volume. Decreasing the temperature causes a proportional decrease in volume.

When the volume is held constant, increasing the temperature of a gas causes a proportional increase in pressure. Decreasing the temperature causes a proportional decrease in pressure.

To visualize this better, the relationship can be demonstrated by an open pan, completely full of water (1 qt. capacity) at 60° F. sea level. Raise the temperature to 200° F., and the water starts to expand (volume increases) to the extent of spilling over the side. Now reduce the temperature to 60° F. and the water will contract (volume decreases) to the original amount (minus the spillage). Here we had a constant pressure, plus an increase in temperature causing an increase in volume, and a constant pressure plus a decrease in temperature causing a decrease in volume.

The relationship between temperature, pressure, and volume will be discussed again in learning objectives on High Temperature Water.

Exercises (255):

1. What happens to a specific volume of water when the temperature is increased and the pressure remains constant?
2. What happens to the volume of water when the temperature is increased proportionately to an increase in pressure?

4-2. Theory of Combustion

Combustion is derived from the Latin verb "combustus," meaning "to burn." Modern dictionaries define combustion as "the action or operation of burning, the state of being on

fire, the chemical combination of a substance with certain elements, usually oxygen, accompanied by the generation of heat and sometimes light." We usually think of combustion in a very active form in which fire and heat are noticeably involved. The combination of iron with oxygen to form rust is also combustion; however, this combustion process is very slow, and the heat produced is not noticeable.

256. List the elements of combustion and tell how the absence of one of the elements affects combustion.

There are certain elements which must be present before combustion can occur.

a. Fuel: We must have a substance to burn. This can be any burnable substance, such as coal, wood, oil, gas, etc., all of which contain carbon and hydrogen.

b. Heat: Every burnable substance has a minimum temperature which must be reached and maintained in order for combustion to occur. This minimum temperature is called the ignition, or kindling, point and in the case of fuel oil, the flash point.

We are all aware that some things burn more readily than others. In general, this depends on how easy it is to turn the particular substance into a gas, because nothing truly burns unless or until it is a gas. This, in turn, depends upon the nature of the substance and on its amount as compared with the amount of heat available to start the process. It is easier to start wood burning than coal, and easier to ignite a twig than a log.

• Air: A sufficient amount of air must be mixed with the combustible gases in order to provide a sufficient amount of oxygen to satisfy the combustion process. Each element or substance needs a certain amount of oxygen for complete combustion.

For all practical purposes, these three elements (fuel, air, and heat) are the only ones involved. In the absence of one or more of these elements, combustion will not take place.

Exercises (256):

1. What are the elements of combustion?
2. How does heat affect the burning process of wood?

3. How does the absence of one of the elements (air, heat, or fuel) affect the combustion process?

4. What is the kindling point?

257. Differentiate between primary and secondary air.

To ignite a fire and have it continue to burn, it must have a continuous supply of air. In heating circles, this is referred to as primary air or theoretical air. Certain volatile combustible gases are formed by the burning of fuel, so more air is needed for these gases to burn properly. This is known as secondary air or excess air.

The total amount of primary air and secondary air required for a good fire depends upon a number of factors. These include the type of fuel, depth of fuel bed, size of firepot, amounts of noncombustible materials, and resistances offered by combustion chamber passages.

Secondary air must be carefully controlled, because too much secondary air will cool the gases below the ignition point and be harmful instead of beneficial. Secondary air that enters the combustion chamber and is too far away from the combustion zone is useless, since the oxygen does not mix with the unburned gases. The air-fuel ratio of oil- or gas-burning heating equipment is generally very closely controlled. In heating units where fuel and air are controlled, combustion efficiency can be held at a maximum.

The smoke produced by a fire is a good indicator of combustion efficiency. When there is too much air, white smoke is produced; when there is too little or too much fuel, black smoke is produced. The highest combustion efficiency is obtained when the proper amount of air is supplied with a minimum amount of smoke.

Exercises (257):

1. The total amount of air needed for the burning of fuel is based on what factors?
2. What is secondary air?

3. Explain the difference between theoretical (primary) air and excess (secondary) air.

258. List the elements of combustion and tell what perfect combustion would involve.

Certain gases are given off during the combustion process. Among these gases are two that are of importance to the fireman. They are carbon monoxide (CO) and carbon dioxide (CO₂). The percentage of these gases depends upon the amount of air (oxygen) mixed with the fuel. The proportion of air being used by a heating unit can be determined by checking the percentage of carbon dioxide in flue gas. This is why the carbon dioxide content of flue gas is considered to be the most direct indication of combustion efficiency.

The most efficient combustion is attained by a fire that liberates the most heat from the fuel, uses the least amount of air, and produces the least amount of carbon monoxide.

In the burning process, two parts of oxygen unite with one part of carbon (fuel) to form carbon dioxide. So a definite amount of oxygen must be provided to burn a given amount of carbon. Any additional oxygen in the air will not enter into the combustion process and does not liberate additional heat. Unburned oxygen robs the furnace of usable heat and carries it out through the chimney. This is one of the big sources of waste in operating a heating plant. When combustion is complete, the resulting flue gas contains carbon dioxide and a trace of free oxygen. When combustion is incomplete, destructive carbon monoxide is present. Incomplete combustion is usually caused by the lack of oxygen during the burning process or by the improper mixing of oxygen with combustible fuel. The percentage of carbon dioxide contained in flue gas is a direct indicator of the degree of perfection being attained in the combustion process.

Perfect combustion would be the result of supplying the exact amount of oxygen required to oxidize, or completely consume, all of the combustibles, using every bit of oxygen. Perfect combustion is seldom, if ever, possible under practical conditions.

Perfect combustion would be attained only if it were possible to burn pure carbon and cause the resulting flue gas to contain 20 percent carbon dioxide. Conditions within a

heating unit are never perfect nor is the fuel ever pure carbon. There will always be less than 20 percent of carbon dioxide in the flue gas. The aim in practical firing is to secure the highest percentage of carbon dioxide attainable, without forming carbon monoxide—consideration being given to the kind and condition of the equipment involved, kind and quality of fuel, etc.

For a given set of conditions, there is a correct maximum carbon dioxide percentage that should be attained, either by hand firing or by automatic combustion control. This percentage depends on the type of fuel and the condition of the fuel-burning equipment used. You, the heating specialist, must know what this percentage is so that you can maintain the efficiency of your fire. If you are not getting maximum efficiency from your fire, make adjustments in the fuel and air supply to bring the efficiency to the desired point. If these adjustments do not bring the carbon dioxide content to the correct point, check the firing equipment. If all oxygen were to be consumed in burning the carbon (fuel), the resulting flue gas would contain approximately 20 percent carbon dioxide and 80 percent nitrogen. Because of the imperfect conditions existing within the average heating unit, however, excess amounts of air must be supplied to the fire so that all of the carbon will come in contact with sufficient oxygen to have combustion.

Most heating units are supplied with too much air in the effort to secure complete combustion. The excess air introduced into the combustion chamber dilutes the carbon dioxide. For example, if perfect combustion were attained by using the exact amount of air (oxygen) to burn a definite amount of fuel, the flue gas would contain about 20 percent carbon dioxide. However, if twice the exact amount of air were introduced into the combustion chamber, the flue gas would contain only about 10 percent carbon dioxide. Four times the amount of excess air would reduce the carbon dioxide content to about 5 percent.

It is the imperfect conditions existing within a heating unit that require excess air to be introduced in an attempt to attain efficient combustion. The amount of air to be admitted can be determined only by testing the flue gas for the percentage of carbon dioxide. Then, the object should be to produce the highest amount of carbon dioxide by using the smallest amount of air possible without producing carbon monoxide.

For burning coal, the best results are obtained with approximately 40 percent

156

excess air, which produces about 12 percent carbon dioxide. Oil and gas burning require less air for good combustion than does coal. Under conditions similar to those for coal, when burning oil and gas with less than 40 percent excess air, the ultimate result is about 10 percent of carbon dioxide for oil and about 8 percent for gas.

Exercises (258):

1. List the elements of combustion.
2. How could perfect combustion be obtained?
3. What indicates the degree of perfection obtained in the burning process?

259. Name the methods of heat loss.

When we speak of heat loss, we mean the heat that escapes into the atmosphere rather than that which is used to convert water into steam or to heat areas where heat is required. Heat losses to the atmosphere are divided into three major classes: losses that go up the chimney; losses that go through the grates; and losses through radiation, convection, and conduction. The heat loss up the chimney is by far the greatest. This heat loss includes excess air loss, unburned fuel loss (smoke), and excess flue gas temperature. The heat losses by excess air and excess flue gas temperature are the greatest sources of up-the-chimney waste. Smoke, contrary to public conception, forms only a small percentage of the total heat loss—not over 2 to 3 percent.

Oxygen is used in the combination process, but nitrogen does not enter into the burning process at ordinary temperatures. For each cubic foot of oxygen that unites with carbon (fuel), 4 cubic feet of nitrogen enter the combustion chamber. Flue gas is usually heated to a temperature of about 500° Fahrenheit, and it is carried by the chimney to the atmosphere with the smoke. Consequently, much of the heat that should be absorbed by the boiler tubes or heat exchanger is wasted because of this excess air

in the combustion chamber as a result of the amount of air being fed into the heating unit.

Heat through radiation, convection, and conduction is lost as the hot medium (water, steam, or air) leaves the heating unit and is transmitted to the areas where it is used for heating.

As the hot medium travels through the lines or ducts, there is some heat loss to those areas that surround the lines or ducts. Even when the heat has reached the area where it is to be used, there is still other heat loss. To maintain a constant room or building temperature, heat must be supplied at the same rate that it is lost. Heat losses taking place in the using area are classified as transmission losses and infiltration losses.

Transmission loss is the heat lost through the confining walls, floors, and ceilings when the outside temperature is lower than the inside temperature. Infiltration loss is the amount of heat needed to equal the temperature of outside air leaking into a building through cracks, crevices, doors, windows, etc.

Exercises (259):

1. What is the greatest source of heat loss?
2. What are the methods of heat loss?
3. What is the name of heat losses that occur in a room?

260. Explain positive draft, state damper control advantages, and tell how cold air leaking into a stack affects draft.

To identify facts about air-fuel ratios, you must have a clear understanding of draft and its control.

In boiler firing, the flow of air and combustion gases is confined to ducts, boiler settings, flues, and stacks. To supply the correct amount of air for combustion and to remove the gases from the boiler setting, this flow must be established and controlled. This can be done by using a stack or mechanical devices, such as fans which act as pumps. Either the stacks or fans or a combination of stack and fans produces a difference in

pressure, causing gas flow through the boiler units.

Draft is a term commonly used to designate a static pressure in a furnace, gas passage, flue, or stack. If the gas within a stack is hot, its specific weight will be less than that of the cool air outside the stack. Therefore, the unit pressure at the base of the stack resulting from the weight of the column of hot gas within the stack will be less than that of the column of external cool air. This difference in pressure will cause a flow of gas through an opening in the base of the stack. In the customary boiler application, the cool air on its way to the stack must pass through the furnace of the operating boilers connected to the stack. In the process of combustion the air is converted to heated flue gas. This heated gas will be displaced by more incoming cool air. The action becomes continuous and a flow is established.

Positive or Negative Draft. To avoid confusion of terms, the value of drafts or draft pressures is referenced to atmospheric pressure at the same elevation, and the plus or minus sign is used to designate whether the draft is at or above (positive draft) or below (negative draft) the atmospheric pressure.

Draft is the pressure difference associated with the movement of flue gases through a stack. Natural draft is always negative and is expressed in inches of water. When the movement of air is supplied by a fan, the draft is said to be forced or induced. When the fan is located so as to push the flue gases through the stack, the draft is forced. When the fan is located so as to draw the flue gases through the combustion unit, the draft is induced. Therefore, in heating operations the draft will be either *natural*, *forced*, or *induced*. A system having both forced and induced draft fans is called a balanced draft system.

Natural Draft. All the early boilers operated with natural draft. The draft necessary to produce the required airflow was provided by stacks or chimneys. Small modern boilers may use natural draft; however, for larger boilers it is not practical or economical to obtain sufficient draft from the stack alone. In these units the stack serves as an aid to a mechanically driven draft fan.

Forced Draft. When air or the products of combustion are caused to flow to, or through, a unit by maintaining them at pressures above atmospheric, the system is said to be under forced draft. The fans that effect this flow are called forced draft fans. In boiler installations, the forced draft fan pushes the air through the combustion-air-supply system to the

furnace. It must have a discharge pressure high enough to equal the total resistance of the air ducts, air heater, burners, or fuel bed, and any other resistance between the fan discharge and furnace (combustion chamber). This makes the furnace the point of balanced draft, since, when the air reaches it, the pressure has dropped to zero. The volume output of the fan must equal the total quantity required for combustion.

Induced Draft. When air, or the products of combustion, are caused to flow to or through a unit by maintaining them at a progressively increasing subatmospheric pressure, the system is said to be under induced draft. This condition is effected by stacks alone which furnish so-called natural draft for low differential pressures, or by stacks supplemented by fans, known as induced draft fans where higher suction are required. The induced draft fan must create a sufficient pressure differential to cause the required quantity of gas at full load to pass through the boilers against the draft loss resulting from flow over all the heating surface and through the gas passages between the furnace and the fan. Normally, the gases pass into a stack or discharge from the fan at substantially atmospheric pressure. The weight of gas used to calculate the draft loss is equal to the weight of the combustion gases plus the weight of air infiltration to the boiler setting from the room, and from the air heater.

Very few applications permit the fan to operate continuously at the same pressure and volume; therefore, to meet the requirements of the system, some convenient means of varying the fan output is necessary. The common methods of controlling fan output are damper control and variable speed control.

Damper Control. A damper is a simple control. It acts as a throttle valve, introducing enough resistance into the system to restrict the fan output to any desired quantity. Damper control is somewhat wasteful, because the fan develops excess pressure energy, which must be dissipated by throttling. The advantages of damper control are lowest cost of all types of control, ease with which it can be operated or adapted to automatic control, the least expensive type of fan drive, a constant speed motor may be used, and it is a continuous rather than a step-type control and is therefore effective throughout the entire range of fan operation.

Variable Speed Control. The most efficient method of controlling output, as far as power consumption of the fan is concerned, is by

varying the fan speed. In using speed control, there is some loss in efficiency, since no variable speed driver is as efficient throughout the entire load range as a directly connected constant speed ac motor. A number of commonly used variable speed arrangements are given below:

Magnetic coupling. The magnetic coupling consists of two windings in a house with a variable field. A change in field strength varies the slip and consequently the speed of the fan.

Hydraulic coupling.

Special mechanical drives. Among the special mechanical drives are the variable pitch V-belts and variable speed transmissions.

Variable speed ac motor.

Variable speed dc motor.

Variable speed steam turbine.

In general all of these methods of speed variation call for a higher investment than the less efficient damper control. An economic balance of first cost and power consumption must, therefore, be effected in selecting the type of drive.

Two-Speed AC Motors. Two-speed motors are often used to supplement damper control. A two-speed motor is less expensive than the variable-speed arrangement with ac drives and will give improvement in the fan efficiency with simple damper control.

We previously mentioned the stack. This plays a very important part in draft. The adjustment or control of air necessary for combustion is influenced considerably by stack characteristics.

All idle entrances leading to the stack should be tightly sealed to prevent cold air leakage to its base. Cold air leakage not only lowers the stack temperature and available draft, but it also increases the quantity of gas the stack must handle.

The stack is subject to the erosive action of ash in the flue gases, to the acid corrosion by sulfur products, and to deterioration incident to continuous exposure to the weather. The erosion or wastage of the stack material normally occurs at stack entrances or at throats and at necked down sections where there is a change in direction or a change in the velocity of the gas. These sections may require replacement at long-period intervals. The use of premium priced abrasive-resistant materials is justified by the reduction of stack maintenance.

Acid corrosion has destroyed steel stacks in as short a period as a few months. Corrosion-resistant metals, refractory coating, and high-temperature, acid-resistant paints are

used to prolong the life of steel stacks. Refractory stacks are subject to deterioration from the chemical and water vapor in the gases. Long exposure in wet weather and insufficient drying during starting-up periods contribute to increased maintenance cost.

Certain stack temperatures are necessary to insure proper combustion efficiency. Good operators check the flue gas temperatures frequently, since once the optimum temperature is established, any variation in flue gas temperature indicates a change in the fuel-air ratio.

Low exit flue gas temperature from a boiler unit is desirable from an efficiency standpoint. Too low a temperature, however, may result in the condensation of sulfuric acid, which will cause corrosion of steel or steel-lined stacks. The limit to which flue gases can be cooled before condensation occurs depends upon the sulfur and moisture content of the flue gas. Normally, sulfurous acid will precipitate out of flue gas at about 290° F., and stacks will corrode if the flue gas is not maintained above this temperature.

If the flue gas temperatures are consistently high, the boiler baffles may be leaking, the gas passages may be dirty, or infiltration of excess air may have occurred.

Exercises (260):

1. Explain positive draft.
2. Name the advantages of a damper control.
3. How does cold air leaking into a stack affect draft?

261. Identify a combustion efficiency detection method and the methods of making a fuel-air adjustment.

Smoke produced by a fire is a good indication of combustion efficiency. By observation, one can determine the relative amounts of air being supplied to a fire. White smoke, or no smoke at all, will indicate too much air. Black smoke indicates too little air, whereas a light brown haze usually indicates good combustion. It is sometimes referred to as an efficiency haze.

There are three methods of controlling

159

combustion which are widely used. One method is to furnish a constant amount of air to the fire and vary the quantity of fuel. Another method is to furnish a constant quantity of fuel and vary the amount of air. The third method is to vary the fuel and air at the same time.

Exercises (261):

1. What is an easy method of detecting combustion efficiency?
2. What are the methods of adjusting a fuel-air ratio?

4-3. Performing a Combustion Analysis

Since it is humanly impossible for an operator to actually see the gases of combustion in a boiler, he cannot know his actual combustion efficiency. He cannot feel exhaust gases and ascertain their degree of heat, he cannot perceive the amount of steam being produced, for steam is an invisible gas. Therefore, it might be well for the operator to look to instrumentation as an extension of his own senses. Actually, they are the windows through which he can see and control what is taking place in his boiler plants. Without them, he could only guess and in most instances his guesses would be entirely wrong or come too late to be of any use.

262. Identify the methods used to perform combustion analysis.

Combustion efficiency is the ratio of the useful heat delivered by the burning fuel to the supply of fuel. The most efficient combustion is that which releases the greatest amount of "usable" heat from fuel. Usable heat is that heat which is available for heating the boiler or furnace.

To really understand how combustion efficiency is measured, you must consider the chemistry of combustion. All fuels consist largely of carbon. The air we breathe consists of 20 percent oxygen. (The remaining air is nitrogen, with small amounts of other gases.) When burning takes place, the oxygen in the air combines with the carbon in the fuel to release a gas called carbon dioxide (CO_2). Each particle of CO_2 gas is made up of 1

carbon atom and 2 oxygen atoms. The "C" in the formula stands for 1 carbon atom, the " O_2 " stands for 2 oxygen atoms.

In this burning process, two atoms of oxygen always unite with 1 atom of carbon. In other words, it takes a definite amount of oxygen to burn a given amount of carbon. The efficiency of combustion can be checked by instruments that measure the carbon content of the combustion gases.

Only the oxygen of the air supports combustion. In perfect combustion, the entire 20 percent of oxygen from the air combines with carbon atoms to produce a corresponding 20 percent of carbon dioxide. By measuring the carbon dioxide of the flue gases, you can determine how efficiently the fuel burns.

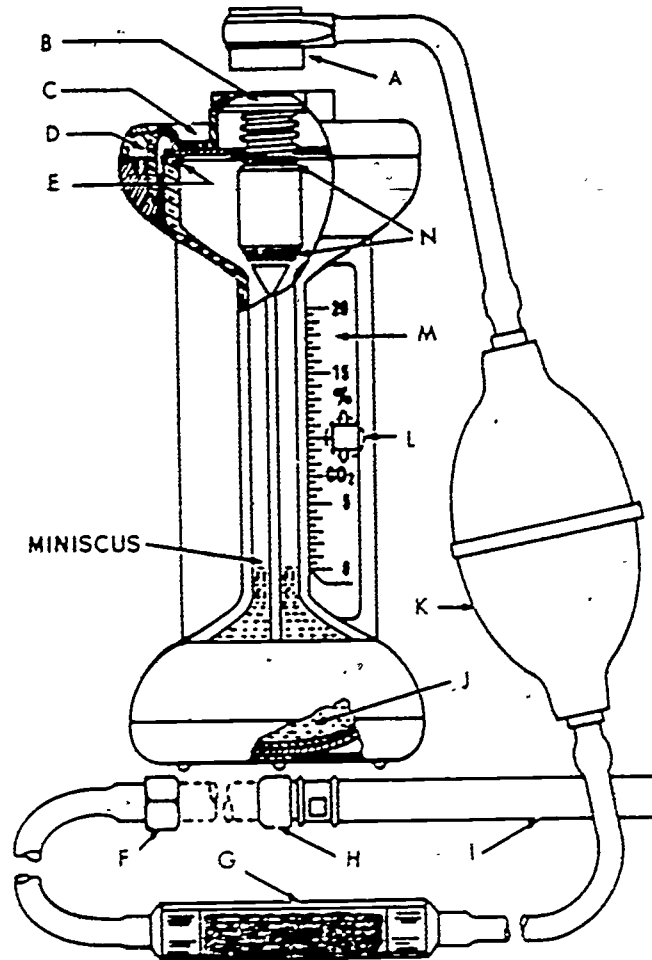
When the fire receives too little air, one atom of oxygen combines with 1 atom of carbon to release carbon monoxide (CO). Unlike carbon dioxide, carbon monoxide is highly poisonous. Breathing very small amounts of carbon monoxide can be fatal.

You might think that all that has to be done to attain maximum combustion efficiency is to supply the fuel with more air than it actually needs (since air is free, anyhow) to make sure there are enough oxygen atoms to combine with the carbon atoms. However, the excess air carries much of the heat directly up the smokestack. This is as inefficient as not providing enough air.

The desirable percentage of carbon dioxide in flue gases varies with the kind of fuel. Experiments have shown that a coal is most efficient when the flue gas contains about 12 percent carbon dioxide. For fuel oil, the content should be about 10 percent, and for gas about 8 percent. Several methods are used to determine the combustion efficiency of a boiler. Some CO_2 analyzers, such as the portable units, are quite simple to operate, whereas the automatic recording types are very complex.

The CO_2 analysis readings can be used with reasonable accuracy as guides to combustion conditions. If combustion is proceeding properly, the chances for incomplete combustion are slight. Water vapor does not show up in the CO_2 analysis, because it has been condensed in the process.

The methods of combustion analysis are the comparison method and the absorption methods. Although there are numerous analyzers, these two methods are the ones used to determine combustion efficiency.



- A. CONNECTOR TIP
- B. PLUNGER CAP
- C. TOP CAP
- D. TOP CAP HOLDING SCREW
- E. GASKET
- F. CONNECTION TUBING TO SAMPLING TUBE
- G. FILTER TUBE
- H. CONNECTION SAMPLING TUBE TO FILTER NIPPLE
- I. FILTER NIPPLE
- J. BOTTOM OF ANALYZER
- K. RUBBER ASPIRATOR BULB
- L. SCALE-LOCKING SCREW
- M. CO₂ SCALE
- N. PLUNGER SEATS

Figure 4-3. Fyrite absorption analyzer

Exercises (262):

1. What should the desirable percentages of CO₂ in flue gas for coal, oil, and gas be?
2. How much oxygen is used in perfect combustion?
3. What are two common methods of performing combustion analysis?

273. Name some equipment used in combustion analysis and list the gases that can be measured with a Fyrite analyzer.

The types of analyzers that are used in combustion analysis are the absorption analyzer and the comparison analyzer. Two common types of absorption analyzers are the typical Fyrite analyzer (fig. 4-3) and the typical Orsat analyzer (fig. 4-4).

The Fyrite analyzer can be equipped to measure the percent of CO₂ (carbon dioxide) or O₂ (oxygen), depending on the chemical used. The Fyrite consists of a container that



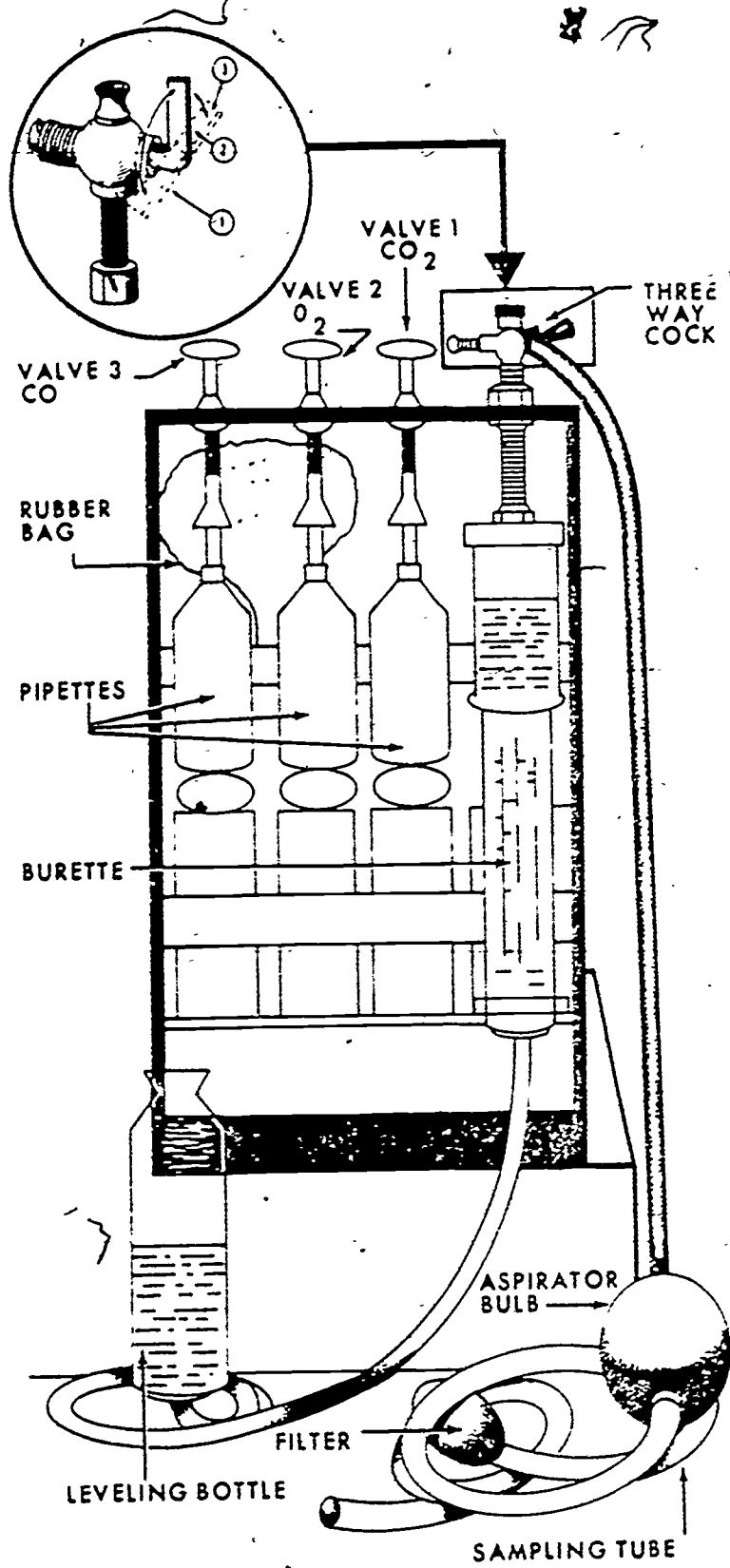


Figure 4-4. A typical orsat analyzer.

162

holds a column of liquid which combines with the CO₂ or O₂ gas. The top of the column has a plunger valve at the point where the gas enters. Along the side of the column is a scale calibrated in percent for measuring the quantity of either gas (each gas has its own scale). A tube and handpump transfer the gas from the boiler stack to the indicator unit.

The Orsat analyzer consists of a water jacketed burette, which is scaled in centimeters. There are three individual pipettes which contain different chemicals to absorb CO₂, carbon dioxide, O₂, oxygen, and CO, carbon monoxide. It also consists of a 3-way cock, valves, a breather bag, leveling bottle, aspirator bulb, and sampling tube.

One of the most common comparison analyzers is the condu-therm, which uses the principle of thermal conductivity for comparison. It consists of a sampling system, an analyzing system, and a recording system. Most comparison analyzers are not portable units, such as the Orsat or Fyrite absorption analyzers, but permanently installed units.

Exercises (263):

1. What are two common types of absorption analyzers?
2. What is the name for an installed comparison analyzer?
3. What gases can be measured with the Fyrite flue gas analyzer?

264. Indicate the procedures used in performing a combustion analysis.

Instructions on operation always accompany the analyzing instrument. Be sure to study these step-by-step procedures before operating any flue gas analyzer. We will, however, discuss the basic principles involved in operation of the Fyrite, Orsat, and condu-therm.

Fyrite. The components of the Fyrite analyzer were covered in learning objective 263.

Connect one end of the analyzer tube and handpump to the smoke outlet of the heating

unit, and attach the other end to the plunger valve on the indicator. Squeeze the bulb the number of times given in the manufacturer's instructions, usually about 18 times, to pump the gas sample into the analyzer. Mix the CO₂ and the indicator fluid by inverting the indicator several times. Read the percentage of CO₂ on the scale at the point where the top of the fluid column comes. Release the CO₂ by depressing the plunger valve on the indicator.

Orsat. Before starting the analysis, check the liquid level in each pipette to assure a correct reading. The pipettes should be at least, but not more than, three-fourths full. A small header connects the top of the burette to all three of the needle valves on top of the respective pipettes. The three-way cock, illustrated in position 1, figure 4-4, connects the header and the burette to the gas-sampling tube. In position 2, it connects the header and the burette to the atmosphere. In position 3, it shuts them off from the air and the gas.

Remove the rubber breather tube on the pipette chambers from the solid plugs so that the tube for CO₂ is left open to the air. Connect the other two, however, to the rubber bag after the chemicals in the pipettes are brought up to the marks on the necks of the pipettes. Exposure uses up the chemicals. With the leveling bottle hung from the bottom of the case and nearly full of tapwater, and the cock at the position 1, pump the bulb to force the gas into the burette and through the bottle. Raise the bottle slowly until the water shows well below the zero mark near the bottom of the burette. Raise and lower the bottle to work out any gas bubbles.

Clamp the rubber connection at the bottle tight with the heel of the right thumb, and raise the bottle about 6 inches. Then move the cock to position 2. Release the tube pressure only slightly to allow the gradual rise of water in the burette. When the level reaches zero, clamp the tube tightly and throw the cock to position 3.

When measuring the gas, go by the bottom of the liquid meniscus (curved surface) and have your eye level with it. Raise the bottle to the position near the top of the Orsat. Open the CO₂ pipette needle valve three or four turns. Water then rises in the burette and pushes the gas over into the pipette.

Keep an eye on the rising water in the burette and have the heel of your thumb ready to clamp off the waterflow. Clamp the tube slightly to slow down the rising water as it approaches the neck of the burette. Stop it at the mark on the neck. Then, with the tube

clamped tightly, close valve 1. Place the bottle on the table or hang it on the bottom of the case for a few seconds to let the CO₂ be absorbed.

Next, hold the bottle so that the water level is even with the bottom of the pipette, open the needle valve, and keep an eye on fluid rising in the pipette. As it nears the neck, slow it down with slight pressure on the rubber tube, then stop it at the mark on the neck, and close valve 1. Now, hold the bottle so that the liquid level, at atmospheric pressure, for the bottle is the same as that for the burette. Keeping your eye on the same level, read the burette at the bottom of the meniscus. Then, record the reading as percentage of CO₂.

To get the percentage of O₂ and the burette reading recorded, repeat the analyzing process with pipette 2. The difference between the first and the second reading is the percentage of O₂. Then make the same analysis with pipette 3. The difference between the second and third reading is the percentage of CO.

After the first absorption and measurement of CO₂ increases on the second analysis, make a third check to make sure the absorption is completely absorbed before you start absorption of the next in series. To be comparable, all gas volumes must be measured at the same temperature and pressure. The burette water jacket gives the constant temperature. This technique measures each gas volume at atmospheric pressure.

Thermoconductivity Analysis. All gases and vapors conduct heat. The fact that gases and vapors possess this property in various degrees offers thermal conductivity as a means of gas analysis. Here is a list of the relative thermal conductivity constants of some common gases. The constants are based on air, which is given a value of 1 at 212° F.

Carbon dioxide (CO ₂)	0.690
Argon	0.707
Water	0.775
Carbon monoxide (CO)	0.924
Nitrogen (N ₂)	0.988
Oxygen (O ₂)	1.032
Methane (CH ₄)	1.72
Neon	1.92
Helium	5.54
Hydrogen (H ₂)	6.94

In the thermal conductivity method of gas analysis, the total thermal conductivity of a mixture of gasses (including the gas to be measured) is compared with that of a known gas, called a standard or reference gas. Air is normally the standard gas. The net thermal

conductivity, or the difference between the thermal conductivities of the mixture of gases and the standard gas, is the quantity used to measure the percentage of one gas in a mixture of gases. To use this quantity as the basis for measuring the percentage of a gas, the net thermal conductivity must vary in relationship as the percentage of the measured gas varies in a mixture of gases.

For this relationship, the gas mixture must consist of the gas being measured and a background gas. The background gas may be one gas or a composition of several gases that, for this type of analysis, act as one gas. If the gas mixture consists of the gas to be measured and one other gas, the net thermal conductivity varies as the percentage of the gas to be measured varies. Most recorders can be calibrated to read the percentage of the desired gas.

There are two cases in which a group of gases may be considered to be one background gas. In one case, the group of gases is composed of gases whose thermal conductivities are identical, or nearly identical, and differing widely enough from that of the measured gas to allow a measurement within the limits of accuracy.

In the second case, the background gas consists of a group of gases whose thermal conductivity constants are not identical. However, all but one of the background gases must maintain a constant—or nearly constant—percentage, depending upon accuracy limitations. Then, the percentage of the gas to be measured increases and decreases as this one background gas (that varies in percentage) decreases and increases. The net thermal conductivity can then be used to measure the percentage of the gas being measured.

Exercises (264):

1. What is the reason for "pumping" the bulb, on the sampling tube of the Fyrite analyzer, 18 times?
2. What is allowed to happen when the three-way cock of the Orsat is in position one?
3. Why is it necessary to depress the plunger valve on the Fyrite CO₂ analyzer prior to taking a CO₂ test?

- 4. You are using an Orsat CO₂ analyzer. What precaution should you take before starting the analysis?
- 5. Why is the leveling bottle raised and lowered when adjusting the Orsat?
- 6. Why is it necessary to repeat the measurement of CO₂ in the flue gas right after the gas has been analyzed?
- 7. Why is a reference gas used in connection with the thermoconductivity CO₂ analyzer?
- 8. You are using a thermoconductivity analyzer with a reference gas that varies in percentage. What happens when the percentage of the gas to be measured increases?

heat loss figure from the figure 100 and you have the total combustion efficiency for a given fuel.

Example You have a stack temperature of 590° F. and a room temperature of 70° F. You have obtained from an Orsat analysis an 8 percent CO₂ reading, and you are burning natural gas. What is your combustion efficiency? The net stack temperature is 520° F. (subtract room temperature from stack temperature). Draw a line from 520° F. and from 8 percent CO₂ reading and they intersect at 24.4, which is 24.4 percent total heat loss. Subtract 24.4 from 100 and you find 75.6 percent of the heat is being used in a satisfactory manner.

Exercises (265):

- 1. How do you find the net stack temperature?
- 2. From the following information obtain the total combustion efficiency.

a. Natural gas—600° F. stack temperature, 80° F. room temperature, and 9.5 percent CO₂.

b. Sub-bituminous coal — 520° F. stack temperature, 70° F. room temperature, and 5 percent CO₂.

265. From given information, compute combustion efficiency.

You recall the meaning of heat loss and how heat loss affects combustion. You have been given the basic facts for determining the CO₂ content of flue gases, so now you can determine the efficiency of combustion.

Scales such as those in figures 4-5, 4-6, and 4-7, are used to determine the combustion efficiency when burning some of the fuels.

To use these scales properly, you must know four conditions. First, you must know the percentage of carbon dioxide in the flue gas; second, the temperature of the flue gas; third, the room temperature; and fourth, the type of fuel being used. With this information at hand, you can determine the combustion efficiency. First, find the difference between the flue gas temperature and the room temperature. Next, find this temperature on the proper scale. Then locate the percent of CO₂ content on the left side of the scale. Draw an imaginary line down from the net stack temperature and a horizontal line from the CO₂ scale. Where these lines intersect represents the total heat loss. Subtract this

266. Cite chemicals used in test equipment.

The Orsat analyzer, as was discussed before, has a major component consisting of three pipettes. The pipettes contain the chemicals which are necessary in determining the percentages of three main gases in flue gas.

One pipette contains the chemical cardisorber. This absorbs CO₂. The second contains pyrogallic acid, which absorbs O₂, and the third pipette contains cuprous chloride or a CO absorber.

The same chemicals that are used for the absorption of CO₂ and O₂ in the Orsat are used in the Fyrite. However, because the Fyrite is able to analyze only one gas at a



time, the chemicals have to be changed for each different gas analysis.

Exercises (266):

1. Name the chemicals that are used to absorb carbon dioxide, oxygen, and carbon monoxide.
2. How many chemicals does the Fyrite absorption analyzer hold?

267. Specify the safety factors involved in repairing or replacing combustion efficiency test equipment.

Never repair or replace any combustion efficiency test equipment without consulting the manufacturer's instruction. These instructions normally contain step-by-step outlines for operation, repair, and/or replacement.

Always observe the strictest safety precautions in performing the repair or replacement of any type of analyzer. The chemicals found in the Fyrite or Orsat absorption analyzers are extremely dangerous. Always avoid skin contact. If chemicals come in contact with the skin, immediately cleanse with soap and water. Rinse eyes thoroughly with water if they become contaminated. Perform maintenance in a well-ventilated area to eliminate the possibility of inhalation of chemical fumes. Follow standard safety practices for toxic substances.

Exercises (267):

1. Why should you consult the manufacturer's instruction before attempting to repair any type analyzer?
2. Chemicals which come in contact with the skin, if left too long, could result in what?
3. What would be the result if a victim was overcome with chemical fumes?

4-4. Fundamentals of Air Pollution Abatement

Normal air contains various amounts of foreign materials caused by natural processes such as wind erosion, sea spray evaporation, and volcanic eruption. These are but small concentrations, far less than those foreign materials caused by man.

Man-made contaminants are mainly caused from combustion, transportation, industrial processes, mining, smelting, construction, and agriculture. Our main concern will be air contaminants caused from combustion.

268. Identify characteristics of smoke and soot.

Improper combustion may cause smoke, and since smoke is a major cause of air pollution, it is usually restricted by public ordinances. When associated with fog, it produces smog, which may be detrimental to aircraft components, electronic devices and other sensitive equipment. It also constitutes a flight hazard.

Soot is composed of minute particles of unburned carbon released during combustion. These particles range in size from 0.01 to 1.00 micron. A micron particle is 1/25,400 inch in diameter. Finely divided soot particles give smoke its characteristic dark color.

Smoke has been defined as "the gaseous and solid products of combustion visible and invisible, including mineral and other substances carried into the atmosphere with the products of combustion." The density of smoke is the extent to which it will obstruct light.

Exercises (268):

1. Smoke is a dark color. Why?
2. How does a heating plant contribute to the smog process?

269. Name the main causes of pollution in respect to heating.

Smoke, soot, ash, and dust (fly ash and cinders) are combustion rejects. Smoke and soot are products of incomplete combustion. These were discussed in learning objective 268.

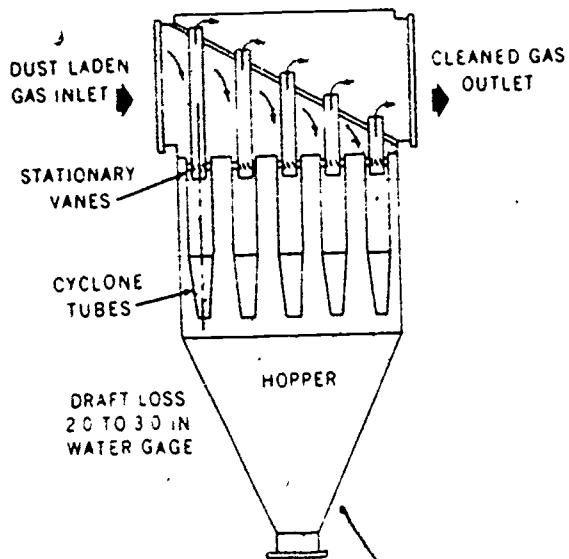


Figure 4-8. Multiple cyclone collector.

Most common fuels have some noncombustible material known as ash. The amount of ash varies in the different fuels. It is practically nonexistent in gas, and exists in oil only to a minor extent. However, in coal the ash content ranges from 5 to 15 percent. Even after perfect combustion, this amount of ash remains. In normal operation, some unburned carbon is usually produced. This material is not the soot that has been already discussed, but consists of particles large enough to see and feel. The mixture of unburned carbon and ash entrained in the flue gases is called fly ash or cinder. Generally, cinder refers to the larger particles and fly ash to the smaller ones. Sometimes both are referred to as "dust." Fly ash and cinders entrained in flue gases are deposited on boiler, economizer, and air heater heating surfaces; in ducts and flues; and at the base of the stack. The lighter particles projected into the atmosphere constitute a public nuisance and, therefore, may be restricted by local ordinances.

Exercises (269):

1. Define ash.
2. What are the main contaminants of air contributed by the heating field?
3. What is "dust" to a heating man?

270. Specify the limits of pollution.

Local dust-pollution ordinances vary, but are usually stated in terms of grains per cubic foot, or pounds per 1000 pounds of flue gas. The maximum limit of the American Society of Mechanical Engineers Code is 0.85 pound per 1000 pounds of flue gas. In practice, this limit is easily reached. If bituminous coal, running 8 percent ash as fired, burns in a stoker that delivers 15 percent of the ash to the flue gas and uses 30 percent excess air, it will produce about 14,000 pounds of flue gas and 12 pounds of dust per 1000 pounds of coal. This means a dust loading of approximately 0.86 pounds per 1000 pounds of flue gas.

Exercises (270):

1. How much dust-pollution is permissible according to the American Society of Mechanical Engineers?
2. Are all ordinances stated in pounds per 1000 pounds of flue gas?

271. List the major control systems of air pollution.

The following are types of collection equipment used to aid in the control of man-made contaminants which contribute to air pollution. Collection equipment installed to reduce stack emission to permissible values can be mechanical or electrical. Their collecting efficiency is measured by comparing the weight of dust removed from a given amount of flue gas with the total quantity of dust present in the gas stream before it enters the collector.

Mechanical Collectors. Mechanical dust collectors use mechanical force to separate the dust from the gas stream. Since the weight of the particle is in some way involved in its operating principle, the collector is more efficient in catching larger particles. There are several types of mechanical collectors; they vary according to the collection method.

One type of collector creates a sudden decrease in gas velocity by enlarging the duct cross section. This causes heavy particles to fall out. Other collectors produce a rapid change in the direction of the gas flow. The sudden change throws the heavier particles

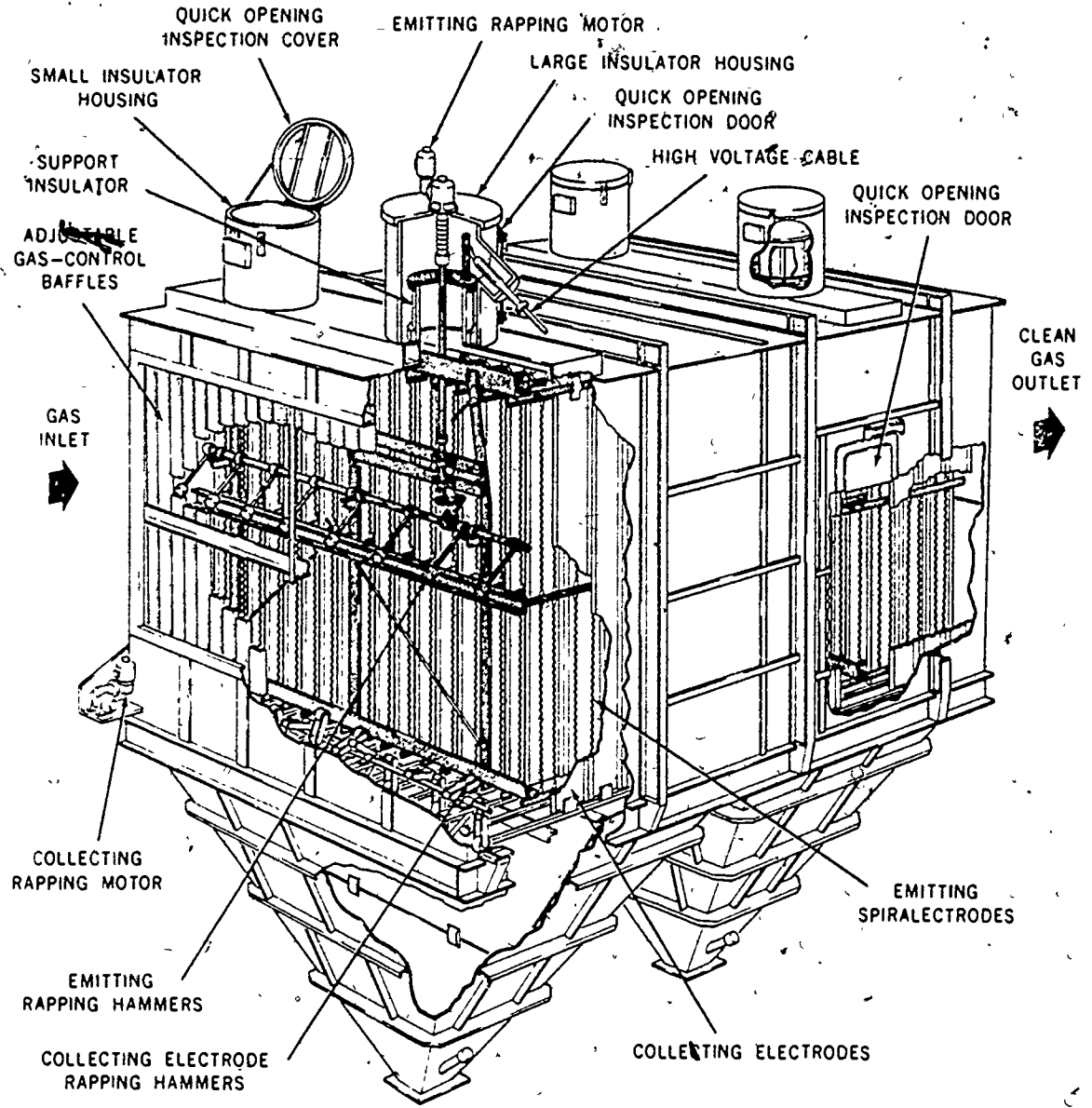


Figure 4-9. Electrostatic precipitator.

out of the gas stream. Other mechanical collectors assist particle drop-out by placing baffles in the gas path to produce particle impingement. These all are low draft loss collectors which range in efficiency from 50 to 60 percent and produce a draft loss of about 0.1 to 0.2 inches of water. They are used, normally to collect relatively coarse particles.

Another type of mechanical collector is the multiple cyclone collector, illustrated in figure 4-8. When it operates, dust-laden gases enter under a sloping dividing plate and are distributed to a battery of tubes. They enter the tubes through a series of fan-like vanes

which swirl the gas streams violently, centrifuging the dust against the innersurfaces of the tubes and permitting the clean gasses to pass upward through the center of the tubes to the stack. This type of collector has an efficiency of 90 to 95 percent for particle sizes ranging from 10 to 20 microns; its draft loss ranges from 2.0 to 3 inches of water. Its efficiency increases for large particles, decreases for smaller ones.

Electrical Precipitators. In the electrostatic precipitators, dust particles passing between high voltage and collecting electrodes are first charged by the high voltage electrodes and then attracted by the collecting electrodes



which have an opposite charge. The particles cling to the collecting electrodes until they are dislodged by special rapping systems and drop in the storage hoppers. Figure 4-9 shows a cut-away view of an electrostatic precipitator. Operating efficiencies of 97.5 percent to 98 percent are normal with this type of precipitator, which works best on fines. These units are sometimes used in combination with mechanical collectors.

Exercises (271):

1. What are the major items of control of air pollution?
2. The device that prohibits the majority of fine particles of contaminants from escaping is what?

Fuels and Fuel Systems

MANY TREES, FERNS, and other types of vegetation have grown, died, decayed, and been covered with layers of the solid particles that form the earth's surface. This vegetation, which was held under great pressure for centuries, formed coal. Petroleum, from which fuel oil is derived, and natural gas are also of organic origin and are believed to have been formed by a similar process. Coal, petroleum, and gas are three major natural sources of fuel for heating systems. In order for you to do your job efficiently as a heating systems specialist, you must be acquainted with these fuels and must know something about their inspection, handling, storage, and characteristics.

5-1. Characteristics of Fuels

Millions of tons of coal are purchased annually by the Air Force. All contracts for coal procured for the Air Force are handled by the Department of the Navy. Virtually all contracts are awarded on the basis of a Bureau of Mines analysis requiring careful periodic sampling and analysis.

To have a better understanding of the properties of coal, you must know its composition. Coal is a mineral formed in the earth by decayed plants, trees, and other forms of vegetation. Chemically, it is composed of varying proportions of carbon, hydrogen, oxygen, sulphur, and noncombustible materials called ash. The several different kinds of coal purchased by the Air Force are anthracite, bituminous, subbituminous, and lignite.

With the invention of radar and the placement of radar units in isolated sites, the need arose within the Air Force for a heating fuel that could easily be transported. Coal was not the practical fuel, especially in the arctic regions where some of the sites are accessible only by air during the winter months. Therefore, liquid fuel was selected for most of

these sites, since it is easily transported and can even be dropped by parachute in emergencies.

The liquid fuel was considerably less expensive to handle than coal and resulted in substantial savings in terms of man-hours and money.

Natural gas is perhaps the closest approach to the ideal fuel. Scientists still are not absolutely sure how natural gas came to be stored in the crust of the earth. But according to the generally accepted theory, countless numbers of plants and animals have been deposited on the ocean floor throughout the ages. The layers of animals and plants have in turn been covered by layers of dirt or mud. As thousands upon thousands of years have passed, the weight of more and more layers of dirt have built up the terrific pressures and created the heat which have had their effect upon the remains of these plants and animals. It is believed that this action has been responsible for converting them into gas and oil.

272. Give the characteristics of coal, oil, and gas.

Coal. Coal has a complex composition that makes classification into clear-cut types difficult. Chemically, it consists of carbon, hydrogen, oxygen, nitrogen, sulfur, and a mineral residue called ash. A chemical analysis provides some indication of the quality of a coal, but does not define the burning characteristics sufficiently. The coal user is interested principally in the available heat per pound of coal, the handling and storing properties, the amount of ash and dust produced, and the burning characteristics. A description of the qualities of coals and their characteristics can best be obtained from publications of the US Bureau of Mines. The significant characteristics of coal are covered in the following paragraphs.

Moisture. All coal contains some natural moisture (ranging from 1 to 3 percent in eastern coals and up to 40 percent in some Texas lignites). This inherent moisture lies in the pores of the coal and forms a true part of it, being retained when the coal is air dried. Surface moisture depends on conditions in the mine, on length of time in transit, and on-weather conditions.

A moisture determination involves heating a specially prepared sample in a preheated oven (at 220°-230° F.) for one hour. Loss of weight divided by original weight gives percentage of moisture.

Moisture must be transported, handled and stored, its presence in large amounts increases the difficulty and cost of these operations. Looked at another way, moisture replaces an equal amount of combustible material and thus decreases the heat content per pound. In addition, some of the heat liberated in the furnace goes to evaporating the moisture in the fuel.

Ash. Ash is the incombustible mineral matter left behind when coal burns completely. It differs from "ashes" as the plant operator knows them, because ashes taken from a furnace always contains some unburned coal. Laboratory determination of ash involves heating dried coal (after the moisture determination) until red hot; then continue heating at about 1300° F. until a constant weight is obtained. Weight of the remainder, divided by weight of the original sample weight, gives the percentage of ash content.

Like moisture, ash is an impurity which increases shipping and handling cost. It must be removed from the furnace and the plant, requiring additional equipment and expense in most cases. Ash constitutes the biggest single factor in fuel-bed and furnace problems such as clinkering and slagging.

Sulfur. Sulfur is an undesirable element in coal for heating-plant use. It plays a part in clinkering and slagging, in corrosion of air heaters, economizers, breechings, and stacks, and in spontaneous combustion of stored coal. The determination of sulfur content in coal is a laboratory process and is not the responsibility of the heating specialist or technician.

Ash-fusion temperature. Ash-fusion temperature is measured by heating cones of ash in a gas furnace. The temperature at which the cone fuses down to a round lump is called the softening or ash-fusion temperature. Ash-fusion temperature serves as the best single indicator of clinkering and

slagging tendencies under given fuel-bed and furnace conditions.

Heating value. The heating value of coal is measured by burning a sample in a "bomb" calorimeter. Filling the bomb with oxygen under pressure insures a complete combustion. The value found by this test is the higher heating value, or gross calorific value. All fuels containing hydrogen have another heating value called the lower or net calorific value. The difference arises because hydrogen burns to form water vapor. Normally, the higher heating value or gross calorific value of a fuel is specified.

Caking and coking coals. Considerable confusion exists regarding the proper use of the terms caking and coking. Heating coal drives off the volatile matter, leaving behind practically pure carbon: this is called coke. It may take the form of small powdery particles or may fuse into lumps of varying sizes and strengths. Formations of coke, in one shape or another, represents an intermediate stage of combustion in any fuel-bed; the difference lies in whether or not a plastic stage occurs and lumps of coal form. Coal which becomes plastic and forms lumps or masses of coke are called caking coals, while those which show little or no fusing action are called noncaking or free-burning coal.

Volatile matter and fixed carbons. In a way not yet clearly known, coal holds combustible gases such as hydrogen, methane and other hydrocarbons, and incombustible gases such as carbon dioxide and nitrogen. This is volatile matter. Heat releases these gases, leaving behind a solid fuel, consisting principally of carbon, but containing some hydrogen, oxygen, sulfur, and nitrogen not driven off with the gases. This is called fixed carbon. Volatile matter is measured by heating a sample at approximately 1750° F. for exactly seven (7) minutes. The loss of weight, minus the moisture, divided by the original sample weight, gives the percentage of volatile matter. Subtracting the percentage of moisture, ash, and volatile matter from 100 percent yields the percentage called fixed carbons.

The percentage of volatile matter indicates the amount of gaseous fuel present and thus has a direct relation to the mechanics of firing.

Coal Analysis. To be able to express coal qualities in figures instead of words, various tests and methods of analysis have been devised. There are two types of coal analysis, namely the proximate analysis and the ultimate analysis.



	Average Btu per Pound	Percent Fixed Carbon	Percent Volatile Matter	Percent Moisture Content
Anthracite	14,440	95.6	1.2	3.2
Semibituminous	15,480	75.0	22.0	3.0
Bituminous	13,880	54.2	40.8	5.0
Subbituminous	9,720	42.4	34.2	23.4
Lignite	7,400	37.8	18.8	43.4

NOTE: All data on ashfree basis

Figure 5-1. Characteristics and types of coals (proximate analysis).

Proximate analysis. In the proximate analysis the percentages of moisture volatile matter, fixed carbons and ash are determined. See figure 5-1. These percentages add up to 100 percent. This analysis is quite easily made and is satisfactory for indicating most of the characteristics which are of interest to the user. For the proximate analysis, the moisture is determined by observing the loss of weight of a sample of coal when dried at about 220° F. To determine the volatile matter, the dried sample is heated to about 1750° F. in a closed crucible and the loss of weight is noted. The remaining sample is then burned in an open

crucible, and the accompanying loss of weight represents the fixed carbons. The unburned residue is ash. In addition, it is customary to determine the total amount of sulfur expressed as a separate percentage, the ash-fusion temperature, and the heating value in Btu's. The Btu is the unit for measuring heat quantity. Specifically, one Btu is the quantity of heat required to raise the temperature of one pound of water 1° F.

Ultimate analysis. An ultimate analysis gives the exact chemical composition of a fuel such as carbon, hydrogen, oxygen, nitrogen,

	Constituents, Percent					
	Oxygen	Hydrogen	Carbon	Nitrogen	Sulfur	Ash
Anthracite	5.0	2.9	80.0	0.9	0.7	10.5
Semibituminous	5.0	4.7	81.7	1.4	1.2	6.0
Bituminous	9.2	5.3	73.2	1.5	2.0	8.8
Subbituminous	29.5	6.2	52.5	1.0	1.0	9.8
Lignite	44.0	6.0	40.1	0.7	1.0	7.3

Figure 5-2. Typical ultimate analysis for coals.

sulfur, and ash. It does not pay any attention to the physical form in which the compounds appear. Such analysis gives data needed for combustion calculations. See figure 5-2.

A brief description of the more common coals used by the USAF is given in the following paragraphs, but it should be recognized that there are no distinct lines of demarcation between the kinds and that they graduate into each other.

Anthracite. Anthracite is commonly referred to as hard coal.

Physical characteristics. Pennsylvania anthracite is dense, shiny black in color and homogeneous in structure, with no marks of layers. It is hard and can be handled with very little breakage. Specially designed coal crushing equipment is used to crush or reduce anthracite to minute sizes for the market. Variations in small sizes are measured in sixty-fourths of an inch; in larger sizes, in quarters and halves of an inch.

The so-called western, and particularly the Arkansas anthracites are really semianthracites. They are dense, but softer than the Pennsylvania anthracite, shiny dark gray in color, and somewhat granular in structure. The grains have a tendency to break off in handling the lump, and produce a coarse, sandlike slack. The granular structure has been produced by small vertical cracks in horizontal layers of comparatively pure coal separated by very thin partings.

Ignition. Although anthracite is comparatively hard to ignite, it burns freely when well started. It is non-caking, and burns smokelessly and uniformly with a short, clear, bluish flame. Semianthracite swells considerably in size when burned, but it does not cake.

Bituminous. This classification covers a wide range of coals, from the high grade bituminous found in the eastern part of the United States to the lower grade coals of the western part. Bituminous, commonly called soft coal, is more widely distributed and more extensively used than any other rank of coal.

Physical characteristics. Low-volatile bituminous coals, also called semibituminous, are of grayish black color and distinctly granular in structure. The grain breaks off very easily; and handling reduces the coal to slack. Because the grains consist of comparatively pure coal, the slack is usually lower in ash than the lumps.

Medium-volatile bituminous coals include the best steam coals and are a transition from high-volatile to low-volatile coal. As such, they have characteristics of each. Many of them have the granular structure, are soft, and

crumble easily. Some have homogeneous structure, with very faint indications of grains or layers. Others are of more distinct laminar structure, are hard and stand handling well.

There are three classes of high-volatile coals—A, B, and C. They vary from a homogeneous structure, with no grains, to a laminar structure. Class A includes the best steaming coal; B, good; and C, fair. Most high-volatile coals are good coking coals. They are hard and stand handling well.

Ignition. Low-volatile bituminous coals cake in the fire, burn with a short, clear flame, and are usually regarded as smokeless. Medium and high volatile coals generally cake in the fire and smoke when improperly burned. Bituminous coals ignite easily and burn readily. This coal has a reputation for being smoky and dirty. However, modern preparation plants permit the coal to be delivered in a clean state, and firing equipment is available to burn it automatically, effectively, and with little or no smoke.

Subbituminous. Coals in the subbituminous classification are found mainly in the Rocky Mountains, the Great Plains, the Northern Pacific states, and Alaska. As the name implies, it is of lower rank than bituminous.

Physical characteristics. Subbituminous coals are brownish black or black in color. Most of them are of a homogeneous structure with smooth surfaces, with no indication of layers. They have high moisture content, although appearing dry. When exposed to air, they lose part of the moisture and crack with audible noise. On long exposure to air they slack.

Ignition. In the fire, they have no caking property and crumble into small pieces. They are free-burning coals.

Lignite. There are vast deposits of lignite in the Dakotas, Montana, Texas, and Alaska. It has limited use in the military establishments in the continental United States and moderate use in Alaska.

Physical characteristics. Lignites are of brown color, and of a laminar structure in which the remnants of woody fibres may be quite apparent. Freshly mined lignite is tough, although not hard, and it requires a heavy blow with a hammer to break large lumps. However, on exposure to air it loses moisture rapidly and disintegrates. Even when it appears quite dry, the moisture content may be as high as 30 percent. Owing to the high moisture and low heating value, it is not economical to transport it long distances.

Ignition. Lignite can be burned quite efficiently on travelling-grate and spreader

176

stokers, and in pulverized form. Because of the tendency of lignite to disintegrate, the fuel bed must not be agitated, since agitation speeds up disintegration.

Fuel Oil. The most important of liquid fuels is fuel oil. It is composed of combustible liquids and a small amount of noncombustible matter. The standard for designating fuel oils in the United States is issued by the Bureau of Standards of the United States Department of Commerce. The oils are numbered in grades 1, 2, 4, 5, and 6, and titled Commercial Standard Grades (CSG).

a. Fuel Oil Grade 1 is a distillate oil intended for vaporizing pot-type burners and other burners requiring this grade and has a heating value of 136,000 Btu's per gallon.

b. Fuel Oil Grade 2 is a distillate oil for general purpose domestic heating to be used in burners not requiring the Grade 1 fuel oil and has a heating value of 138,500 Btu's per gallon.

c. Fuel Oil Grade 4 is an oil for burner installations not equipped with preheating facilities and has a heating value of 145,000 Btu's per gallon.

d. Fuel Oil Grade 5 is a residual type of oil for burner installations equipped with preheating facilities and has a heating value of 148,500 Btu's per gallon.

e. Fuel Oil Grade 6 is an oil for use in burners equipped with preheaters, thereby permitting the use of a high-viscosity fuel and has a heating value of 152,000 Btu's per gallon.

Viscosity. The relative ease or difficulty with which an oil flows is called viscosity. Viscosity is measured by the time in seconds a standard amount of oil takes to flow through a standard orifice in a device called a viscosimeter. Various viscosimeters are available; but the usual standard in this country is the Saybolt Universal, or the Saybolt Furol for oils of high viscosity. Since viscosity changes with temperature, the viscosity test must be made at a standard temperature, usually 100° F. for Saybolt Universal Viscosity Test and at 122° F. for the Saybolt Furol Test.

Viscosity indicates how oils will behave when pumped and shows when preheating is required and what temperature must be maintained. A low viscosity allows the fuel to flow readily through supply lines and to be broken up by atomizing-type burners.

Weight, flashpoint, and pour point. Fuel oil vapors are heavier than air and tend to settle into pits and low areas, creating mixtures which may be fire and explosion hazards.

Fuel oil is lighter than water and spreads over the surface of water.

Flashpoint represents the temperature at which an oil will give off enough vapor to make an inflammable mixture with air.

The pour point represents the lowest temperature at which an oil will flow under standard conditions. Including pour point in specifications insures getting oil that will not cause handling troubles at expected low temperatures.

Flammability. Gas and vaporized fuel oil heated to ignition temperature are combustible when mixed with the proper amounts of air. If ignition occurs inside a container or within a confined space, destructive pressures usually develop. Although fuel oil does not vaporize as easily as gasoline, the dangers caused by the accumulation of vapors in low areas or confined spaces are serious.

Chemical effects. Although fuel oil does not deteriorate lubricants, rubber, and pump seals as rapidly as does gasoline, all materials coming in contact with fuel oil should, nevertheless, be resistant to this deterioration.

Gas. Gaseous fuels are usually classified by the source from which they originate, which in turn determines their chemical composition. The heat value (expressed Btu per cubic foot) varies with the type of gas being used and will determine the quantity required for the specific capacity of the heating system. In the United States there are several types of gas. The ones principally in use are natural gas, manufactured gases, and liquefied petroleum gases.

Natural Gas. The first natural gas well to be drilled in the United States was located in Fredonia, New York, in 1821. It was not until some time later that natural gas became popular as a heating fuel. Natural gas finally came to the front as a heating fuel following the discovery of new gas fields, and as more efficient means of transportation were developed.

Gas burns efficiently and clean, and the flow of gas can be easily controlled automatically. Thus, it cuts operational costs by eliminating the need for full-time operators, except in very large plants. A major drawback to using natural gas is that it is not always feasible to store it in containers aboveground. Consequently, when the gas supply is interrupted, another fuel must be temporarily substituted. Natural gas is, however, stored deep underground in great quantities by gas companies during the summer for use during the winter or when consumption is greatest.

Natural gas is colorless and odorless in its natural form, however, a distinctive odor is added to this gas as a safety factor to warn of leaks. Natural gas is lighter than air and upon escaping rises and mixes with air.

Composition of natural gas varies with the source, but methane (CH₄) is always the major constituent. Most natural gases contain some ethane (C₂H₆) and a small amount of nitrogen. Natural gas, like all gaseous fuels, mixes readily and intimately with air to form a cleaning-burning, combustible mixture. Since natural gas is substantially free of ash, combustion is practically smokeless and there are no boiler slagging or air contamination problems.

Manufactured or Byproduct Gases. This group consists of those gases that are manufactured by converting low grade liquid and solid fuels (oil, coal, wood, or waste material) into gaseous form, or which are byproducts from furnace or processing operations. The most common manufactured gases are carbureted water gas, oil gas, and producer gas. They are ordinarily used at or near the production point, since high manufacturing cost rules out the added expense of distribution.

The most common byproduct gases are blast furnace gas, casing head gas, refinery gas, and sewage gas. This group of gases is usually used at the source of production (oil fields, refineries, disposal plants) It is produced in varying quantities, must be used as fast as it is produced, and can be piped only comparatively short distances. For this reason, its use for heating is limited to those installations near the producing plant. This gas carries a large amount of dust and therefore, must be partially cleaned. Usually heating units which burn blast-furnace gas are designed with oversize combustion chambers, since large quantities of gas must be burned to obtain a minimum amount of heat due to the low heating value of the gas. Liquefied Petroleum Gases (LPG). The principal liquefied petroleum gases are propane and butane. They are closely related and are all derived from natural gas or petroleum refining gas. These gases are on the borderline between a liquid and a gaseous state.

Propane. Propane is generally available by bottle or cylinder or in bulk form. Propane is usually the most common of the liquefied petroleum gases.

Butane. Butane is generally not available in bottles or cylinders but is more common in bulk form. It is quite common to have propane mixed with butane to obtain a desirable heat value and boiling point.

Characteristics of Liquefied Petroleum Gases. At ordinary atmospheric pressure with necessary heat of vaporization added, butane will boil or change from a liquid to a gaseous state above 32° F. In other words, if its temperature is 32° F. or lower and the pressure is atmospheric, butane will remain a liquid. To convert this liquid to a gaseous form the boiling or vaporization point must be obtained. The boiling point of propane however is -42° F.

Liquefied petroleum gases are compressed into suitable containers to a pressure up to 200 pounds per square inch, at the refinery. At these pressures, the gas is changed to a liquid. When the gas is used, the pressure must be reduced to approximately 6 to 8 pounds per square inch. This reduction in pressure causes the liquid to change to a gas. Liquefied petroleum gases are readily combustible and produce an intense heat.

Exercises (272):

1. Which type of coal is referred to as hard coal?
2. Which type of coal has the most moisture content?
3. You are operating a heating plant that is accessible only by air for about 5 months of the year. Which type of fuel would you most likely be using?
4. Which grade of fuel oil has the highest viscosity?
5. What grades of fuel oil are generally used with preheating equipment?
6. What is a major drawback of using natural gas?
7. Which type of gases must be used as soon as they are produced?

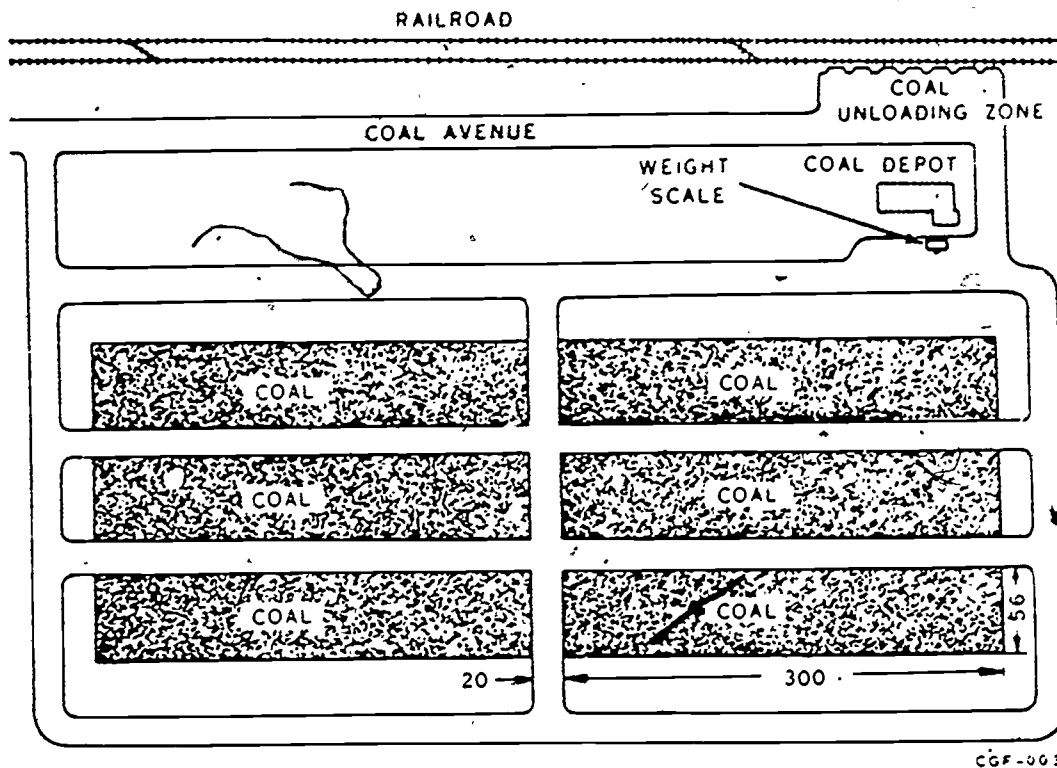


Figure 5.3. A typical coal storage layout.

8. You are using gas in an area where temperatures average well below zero. Which gas would you most likely be using? Why?

5-2. Fuel Storage

The Air Force stores fuel to have available at all times a reasonable supply in accordance with the requirements of the installation equipment, and to provide an emergency supply for use in case of interruption of the normal delivery schedule.

273. Specify storage requirements for coal.

Coal should be stored only on ground which has been properly graded and surfaced. A typical coal storage layout is shown in figure 5-3. The improper storage of coal can cause spontaneous combustion. Usually, some of the coal is wasted when it is stored on soft ground, because it sinks into the ground and mixes with the dirt and other foreign matter. When this situation occurs, the foreign particles in the coal usually warp the grates of heating units, the replacement of which results in the loss of manpower. There is also

extra wear and tear upon the equipment used to move such noncombustible materials. Heavy coal losses usually occur when the coal is stored without proper drainage. The paragraphs that follow contain some of the rules which should be followed to minimize the loss of coal during storage.

Coal should never be stored near sources of heat, and fresh coal should not be piled over old coal. The storage piles and storage surfaces should be kept free of metal scrap, rags, paper, waste, scrap wood, glass bottles, and other foreign materials.

Some sizes of bituminous coal, including lump, egg, and nut, are not piled higher than 18 feet, to prevent spontaneous combustion, except with the specific approval of the Air Force command concerned. Storage of bituminous, run-of-mine coal should be limited to a maximum height of 13 feet, unless higher stock piling is approved by the Air Force command concerned. Anthracite coal may be stored to any desired height within economic limits.

Different sizes and kinds of coal should be stored in separate piles according to grade, size, and function. There are, however, a few exceptions. Anthracite coals of the same size, regardless of origin, should be stored in the same pile. Bituminous coal of the same size,

mined from the same vein or of the same characteristics, should be stored in the same pile. Bituminous lump coal, with top size variation not to exceed 5 inches, and bituminous egg, with top size variation not exceeding 3 inches, should be stored in the same pile, if they have the same characteristics.

Coal is generally stored in stock piles 300 feet long and 56 feet wide. An allowance of 20 feet should be made between the stock piles for firebreaks. The firebreaks also serve as driveways and loading zones. This arrangement permits efficient truck loading and travel, ample room to operate coal handling equipment, and sufficient room to spread or shift the coal in case a fire starts in one of the stock piles. The shifting and rehandling of coal in stock piles should be held to a minimum to prevent the breakage and disintegration of coal into smaller pieces.

The discharge end of a conveyer stacker should be kept as close as possible to the top of the stock pile or truck bed to avoid breaking the coal by dropping it too far. When the maximum height of the stacker is reached, it should be moved a sufficient distance to discharge the coal on the side and near the top of the stock pile. The distance of the move should not exceed 6 feet.

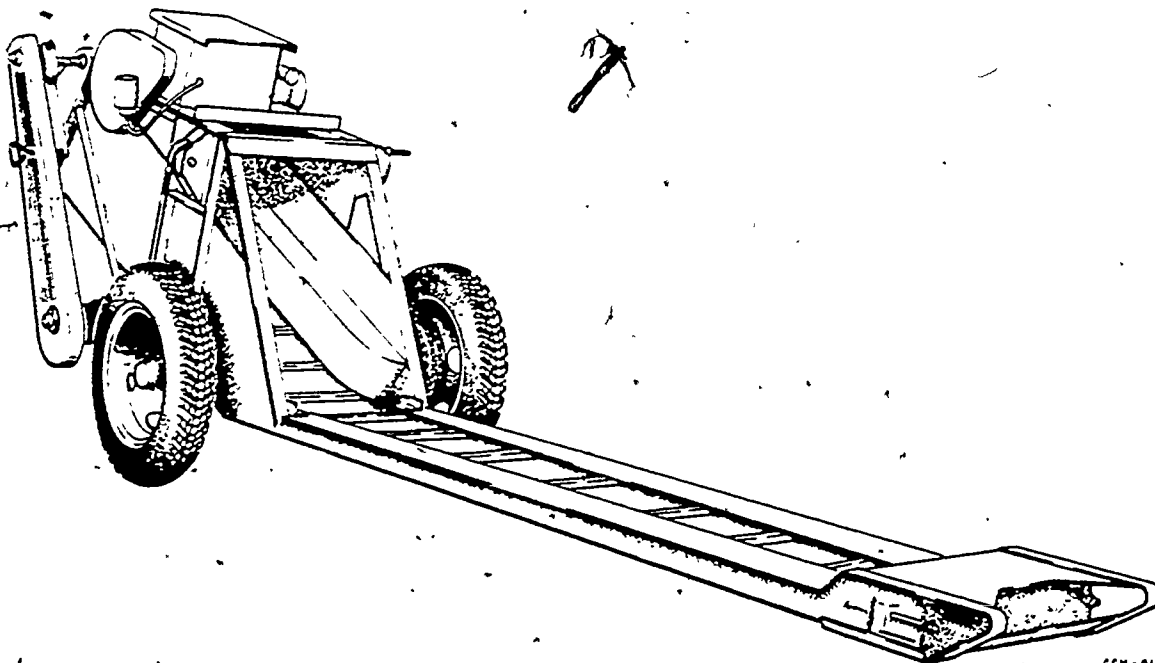
Use good judgment when storing coal with a clamshell crane. Take care to keep coal

breakage at a minimum. Fine or slack coal creates a fire hazard in the coal storage pile.

It is sometimes necessary to shift storage stock piles at AF bases where a large tonnage of coal is stored. If this work is done with a clamshell crane, the shift can be made with very little damage to the coal, provided the coal is not discharged from the bucket until the bucket is lowered close to the pile so that only enough room is allowed to open it. The position of the crane is also arranged to reduce the angle of swing, thus saving time and increasing the daily tonnage moved. Storage stock piles of sized coal should never be shifted by pushing them with a bulldozer.

Coal should be stored in uniform stock piles. The sawtooth piling that causes marked variations in the height of a pile should not be permitted. To avoid sawtooth piling, the conveyer stacker or clamshell must be moved only short distances. These short moves make it possible to run a stock pile of uniform height, provide a natural side slope on the pile, reduce the breakage of coal, eliminate lowering and raising the conveyer stacker, and save storage space. Coal stored in irregular piles is very difficult to inventory.

Storage piles should be inspected at least once a week for evidence of excessive heating or spontaneous combustion. Such evidence is ordinarily discovered by evidence of steam, or



CGO-018

Figure 5-4. Car unloader.

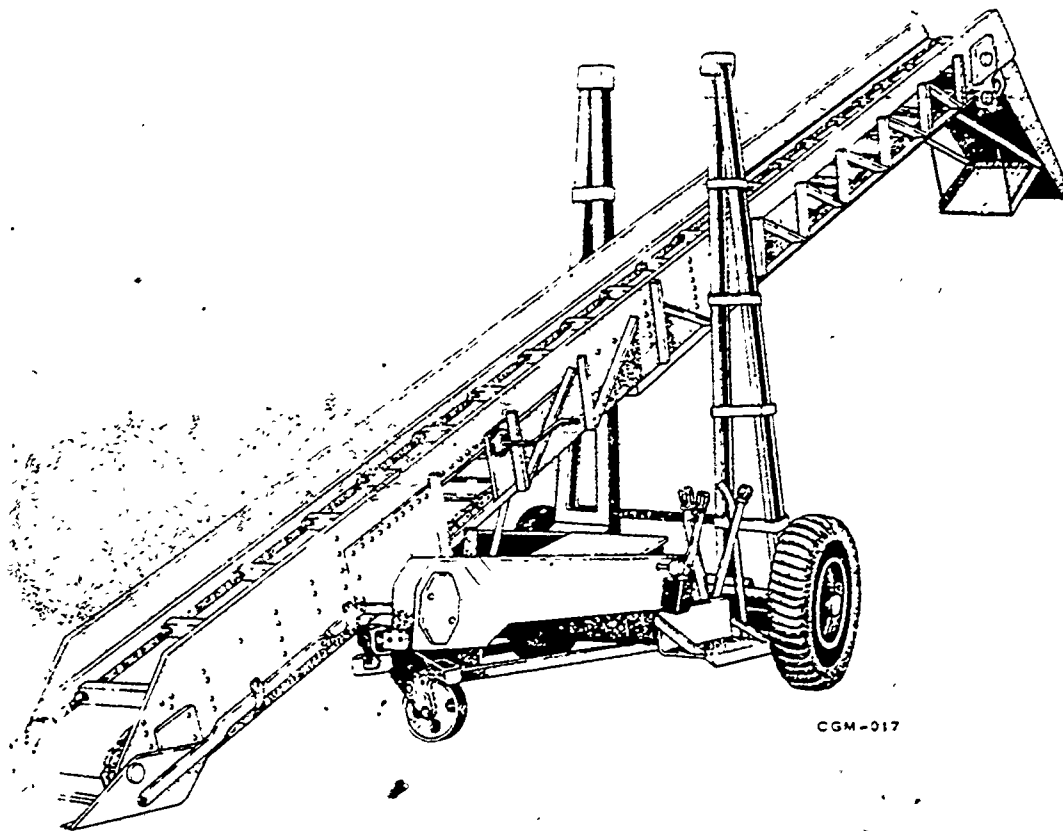


Figure 5-5. Truck loader.

by the odor of coal gases escaping from the coal mines.

Water should not be applied to burning storage coal piles to extinguish a fire, or to storage coal piles which are heating. Water has a tendency to aggravate both conditions, and spreads the fire or hotspots to other points in the storage pile. Water should be applied to hot or burning coal only after it has been removed from the stock pile. Hot or burning coal should be removed from a stock pile preferably with clamshell cranes, power shovels, or all-metal conveyers. Removing hot or burning coal by hand with a shovel is slow and dangerous. All coal in the vicinity of the fire which has a temperature of 100° F. or more should be removed. Any coal which has been damaged by heat or fire should be aerated and used at once. If the entire stock pile or a large portion of it shows danger of heating, the entire pile or affected portion should be removed, aerated, and restored. Slack coal or screenings should be thoroughly compacted after the temperature has dropped to a safe point.

Exercises (273):

1. Why should the height of the storage piles of some coals be limited?
2. What should you do when a fire is discovered in a coal pile?
3. Firebreaks, driveways, and loading zones require what distance between coal storage piles?

274. List equipment used in maintaining coal storage areas.

The types of equipment used in maintaining coal storage areas are as follows:

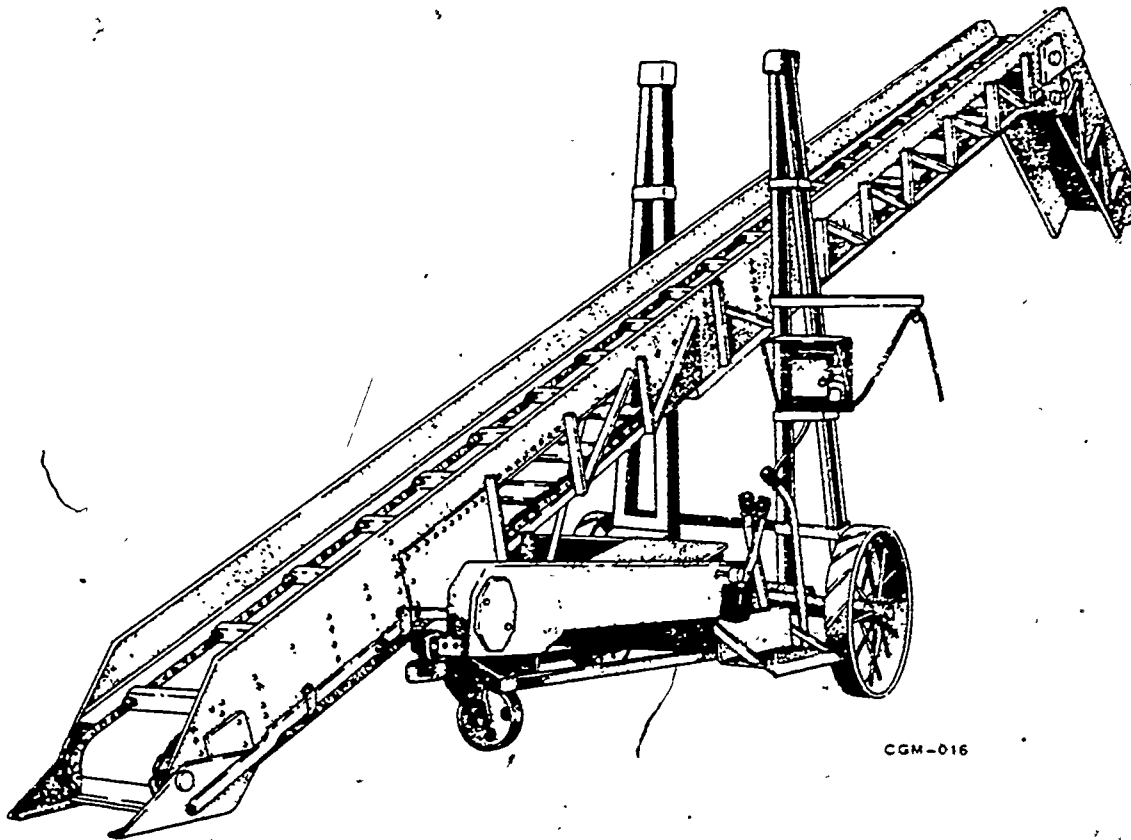


Figure 5-6. Conveyer stacker.

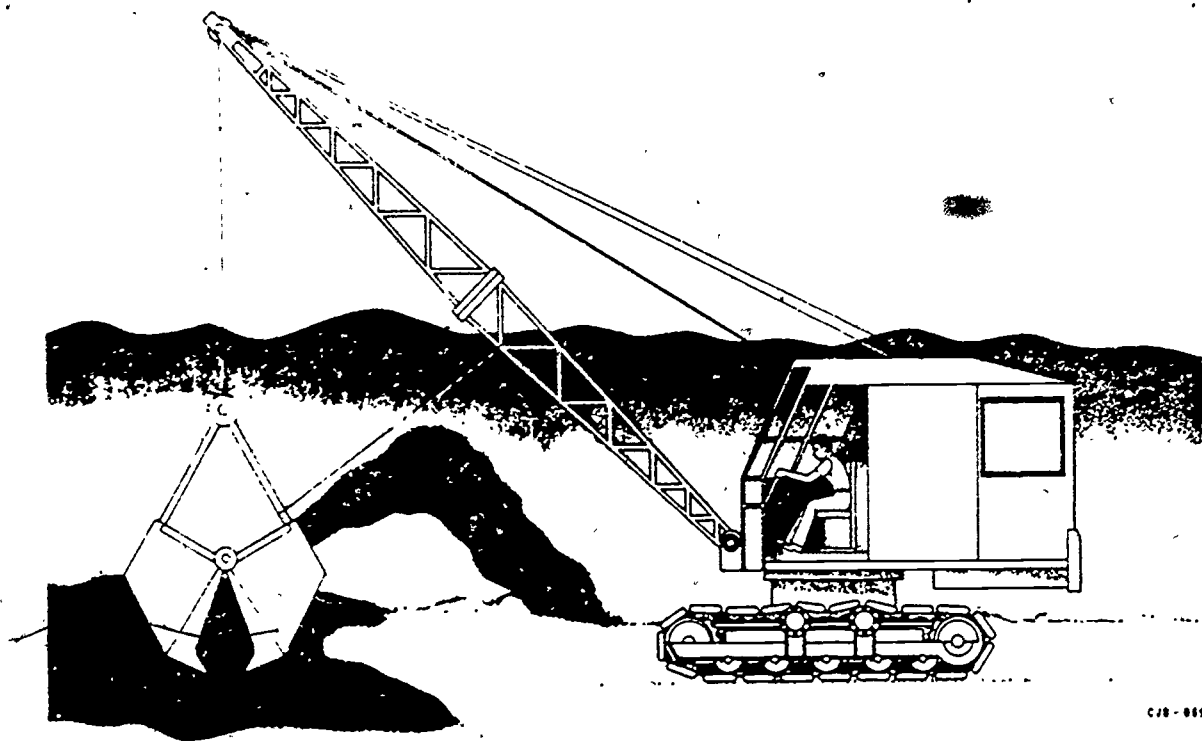
Portable conveyer equipment consists of a car unloader, truck unloader, and conveyer stacker. One such unit is authorized for each 5000 tons of coal handled annually at an installation. A car unloader (fig. 5-4) has a prime function to receive coal discharged by gravity from a railroad car or pit and convey it to the truck loader or conveyer stacker. The truck loader (fig. 5-5) is to reload or pick up coal from stock piles and convey it with maximum speed, minimum breakage, degradation, or spillage to delivery trucks. The conveyer stacker (fig. 5-6) is to receive coal from the car unloader, truck loader, other conveyer stacker or delivery truck and convey it to the stockpile, or to move or shift coal previously stockpiled.

Another item of equipment, which is not listed as standard coal-handling equipment, but is highly effective in general coal handling uses, is the clamshell crane. A clamshell crane, such as the one illustrated in figure 5-7, is used to unload all types of coal cars (with the exception of self-clearing hopper cars) to trucks, from cars to stockpiles, and from

stockpile to truck. It is also used to move stockpiles and can be used to switch or move railroad cars. It is especially useful in digging out hotspots or heating coal from a stockpile.

Exercises (274):

1. What is the item of equipment which serves as a highly effective means of maintaining coal storage areas?
2. An installation with coal consumption of 1500 tons could be authorized how many portable conveyer units?
3. List equipment used in maintaining coal storage areas.



C-8-889

Figure 5-7. Clamshell crane.

275. Explain why preheating of fuel oil is common and state the advantages of electric preheaters.

Because they are highly viscous when cold, residual oils No. 5 and No. 6 must be heated. Preheating these oils to reduce their viscosity decreases the pumping power required, the wear on the pumps, and the size of the pipe necessary to handle the oil. The heating also improves combustion.

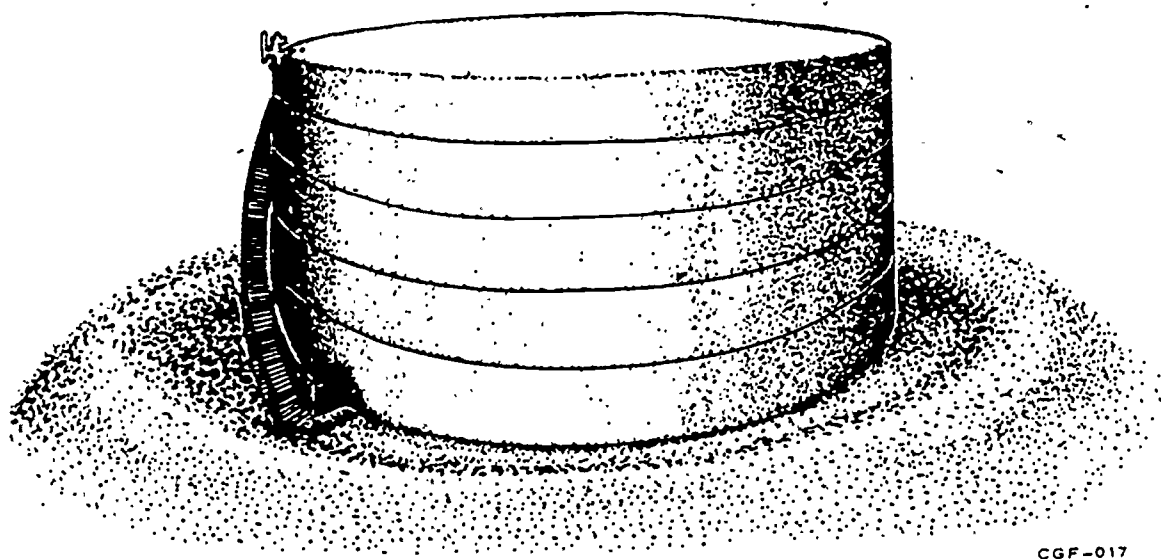
Heating usually is carried out in two steps. The first heating is done in the oil storage tank itself, or at the tank outlet, to facilitate pumping. A viscosity of 700 SSF (seconds Saybolt Furol) is adequate for pumping. This is obtained at a temperature of about 100° F. The second heating is done in a fuel oil heater located between the pump discharge and the fuel oil burners. Viscosities of 150 SSU (seconds Saybolt Universal) for mechanical atomizer burners are usually adequate. These are obtained at approximately 210-220° F. Use the lowest temperature that produces satisfactory operation, *avoid overheating*. The usual types of fuel heaters are steam, electric, and below-the-waterline.

Steam Heaters. As a rule, these heaters are of the shell and tube type, with a device to regulate the temperature of oil leaving the

heater. The most common device is a thermostatic bulb, immersed in the oil line at the heater outlet, which operates a steam control valve. A small relief valve usually protects most steam heaters from excessive pressure in the oil side. A safety valve of adequate size is also necessary to protect the steam side of the heater from excessive pressures. A steam trap to handle the condensate is necessary.

Electric Heaters. Electric heaters are usually employed when the fuel oil heating installation is located far from steam lines or when the plant has to be started on residual fuel oil without the assistance of an auxiliary fuel. One type of electric heater consists of a sheathed resistance element, immersed directly in the fuel oil to be heated. A relay actuated by a thermostat interrupts the heater current when the proper temperature is reached.

Below-the-Waterline Heaters. These heaters are of the shell and tube type. They operate much like the steam heaters discussed above. The main difference is that they use hot water from a steam or hot water boiler instead of steam. Heaters used in a steam boiler installation are installed with their centerlines below the boiler waterline. The boiler supplies hot water to heat the fuel oil. Generally, a



CGF-017

Figure 5-8. Above ground storage tank.

gate valve located in the water outlet line controls water circulation and oil temperature. The water may be returned directly to the boiler. However, this introduces the possibility of oil entering the boiler. In some installations, the water is first passed through an oil separator, where any oil entrained from oil leaks is detected and removed. Forced or natural water circulation, depending on the type of installation, is used.

Exercises (275):

1. Why is it necessary to preheat some grades of oil?
2. What are the advantages of using electric preheaters?

276. Describe functions of some of the units of a fuel oil supply system.

Among the units of a fuel oil supply system are storage tanks, pumps, valves, and strainers.

Storage Tanks. Oil storage tanks can be of either the above- or below-ground type.

Above-ground storage tanks. Above-ground storage tanks are usually cylindrical and constructed of steel. They may be either horizontal or vertical. Installed tanks are generally surrounded by dikes of approved construction which have a capacity at least

equal to that of the tank or tanks they surround. The tanks may have some or all of the following auxiliary connections and equipment: fill, vent, return, low suction, high suction, sludge pump out, steam and condensate piping; suction heaters; temperature and level indicators; ladders; and access manholes. Electrical grounding of aboveground steel storage tanks is required to safely discharge static electricity, which may build up an electrical potential on the tank. Grounding is important, since it prevents fires and explosions which could be caused by sparks discharged by static electrical charges.

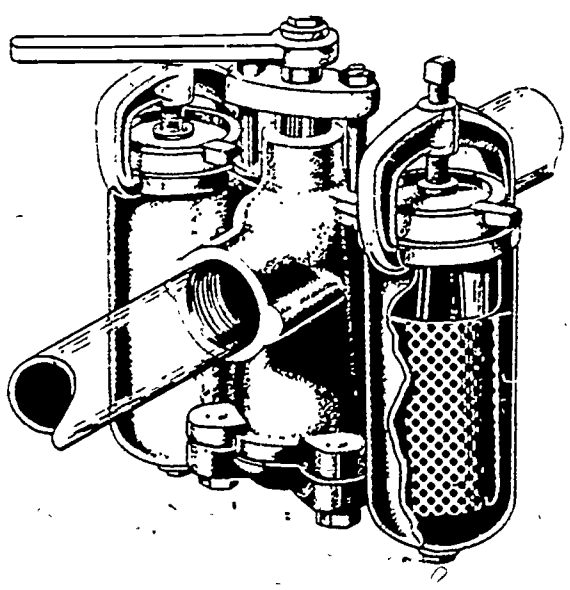


Figure 5-9. A typical duplex fuel oil strainer.

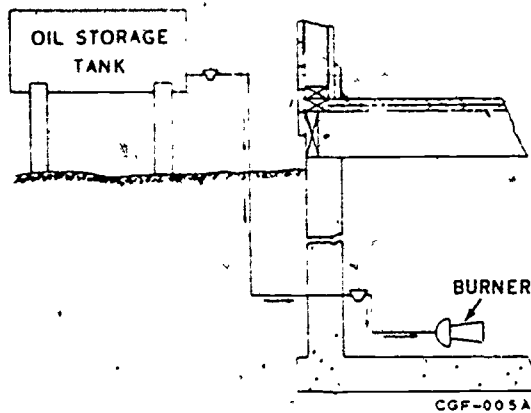


Figure 5-10. A single-pipe, gravity-feed oil supply system.

Figure 5-8 shows an above-ground storage tank.

Below-ground storage tanks. Underground fuel oil storage tanks are usually of the all-welded steel type, with a suitable exterior protective coating. A reinforced concrete slab is generally used as the tank foundation. The steel bottom of the tank is securely anchored to the foundation slab at frequent intervals to prevent failure or lifting due to water pressure between the slab and the steel tank bottom. The extent of this anchoring should be adequate to meet the ground-water condition where the tank is located. Underground tanks have the same type of auxiliary equipment as above-ground storage tanks. Under certain soil conditions, corrosion of below-ground steel storage tanks may occur. This corrosion is generally associated with a flow of electric current away from the metal. To prevent this, cathodic protection is often used. Cathodic protection consists basically of a suitable electrical potential applied to the tank to make it cathodic (negative) to the surrounding soil. This produces a current flow to the corroding metal and reduces corrosion to a minimum.

Pumps. The pumps used in fuel oil supply systems are piston, gear, centrifugal, and turbine types. They are used either to pump fuel from the storage tanks to the burner or to pump the excess oil from the burner to the storage supply tank. A pressure relief valve is generally used on the discharge line.

Master Valves. Master valves in the burner manifold control the fuel oil flow to the burners. In addition, each line supplying fuel to a burner is equipped with an individual stop valve.

Strainers. It is essential that the fuel oil supplied to oil burners be clean; otherwise,

the passages in the burners will clog. Fuel oil is kept clean by means of oil strainers. A typical duplex fuel oil strainer is shown in figure 5-9. This unit has two strainers in one body. It is constructed in such a manner that the flow of fuel can be directed through either of the strainers by the use of the hand lever. In this way, one strainer can be cleaned while the other is in use.

Exercises (276):

1. Why are fuel strainers installed in oil supply lines?
2. There are five 1500-gallon fuel oil storage tanks in a line. What should be the capacity of the dike or dikes surrounding these tanks?
3. Describe the functions of the following units of a fuel oil supply system.
 - a. Pumps.
 - b. Master valves.
 - c. Strainers.

277. Identify each of the fuel oil supply systems.

Oil is transferred from the storage tanks to the burners by either force pumps or gravity. Since it is not practical to maintain accurate regulation to compensate for varying loads,

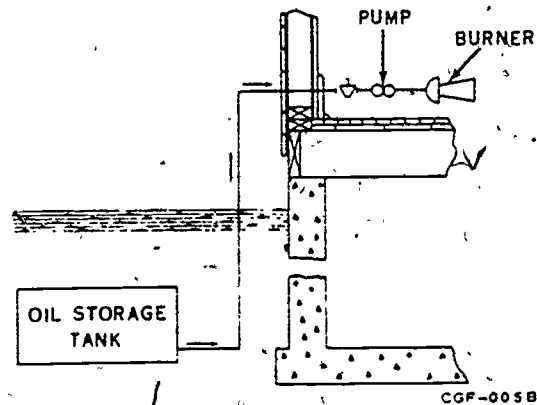


Figure 5-11. A single-pipe, forced-feed oil supply system.

provision must be made in some systems to return the unused oil to the storage tank or to recirculate it through the supply system. The following paragraphs are devoted to a discussion of some of the commonly used types of fuel oil supply systems.

Single-Pipe, Gravity-Feed Oil Supply System. Single-pipe, gravity-feed oil supply systems are used in small space heater installations. An illustration of this type of system is shown in figure 5-10. In this system, the oil storage tank is installed at a higher level than the burners. This allows the oil to flow to the burners by gravity. No provision is made for the return of unused oil to the storage tank, since the oil flow is controlled by the amount that is used by the burner.

Single-Pipe, Forced-Feed Oil Supply System. The single-pipe, forced-feed oil supply system is normally used where it is impossible to use a one-pipe, gravity-feed system. In this type of system, the storage tank is usually below the level of the burner. An oil pump, usually a positive displacement type, is installed in the system to force the fuel oil to the burner. This system recirculates the unused oil through the pump. See figure 5-11.

Double-Pipe, Gravity-Feed, Forced-Return Oil Supply System. Fuel oil supply systems of this type are designed for larger installations

than those mentioned previously. The fuel supply line in this system is essentially the same as for a single-pipe, gravity-feed system. The difference between the two systems lies in the methods of handling excess fuel oil. This is accomplished in this system by the addition of a fuel oil return line. Figure 5-12 shows a diagram of this system. Extreme care must be exercised when operating system of this type, since failure of the return pump can cause the burner to flood, thus forming a pool of oil in the combustion chamber.

Double-Pipe, Forced-Feed, Gravity-Return Oil Supply System. This type of supply system is perhaps the most common found in central heating plants. A diagram of it is shown in figure 5-13. This system is similar to a two-pipe system. The fuel oil is forced to the burner by a pump, and the excess oil is returned to the storage tank by gravity.

Exercises (277):

1. What determines the amount of oil flowing to a gravity one-pipe oil supply system?
2. Which system is subject to flooding of the combustion chamber due to failure of a return pump?

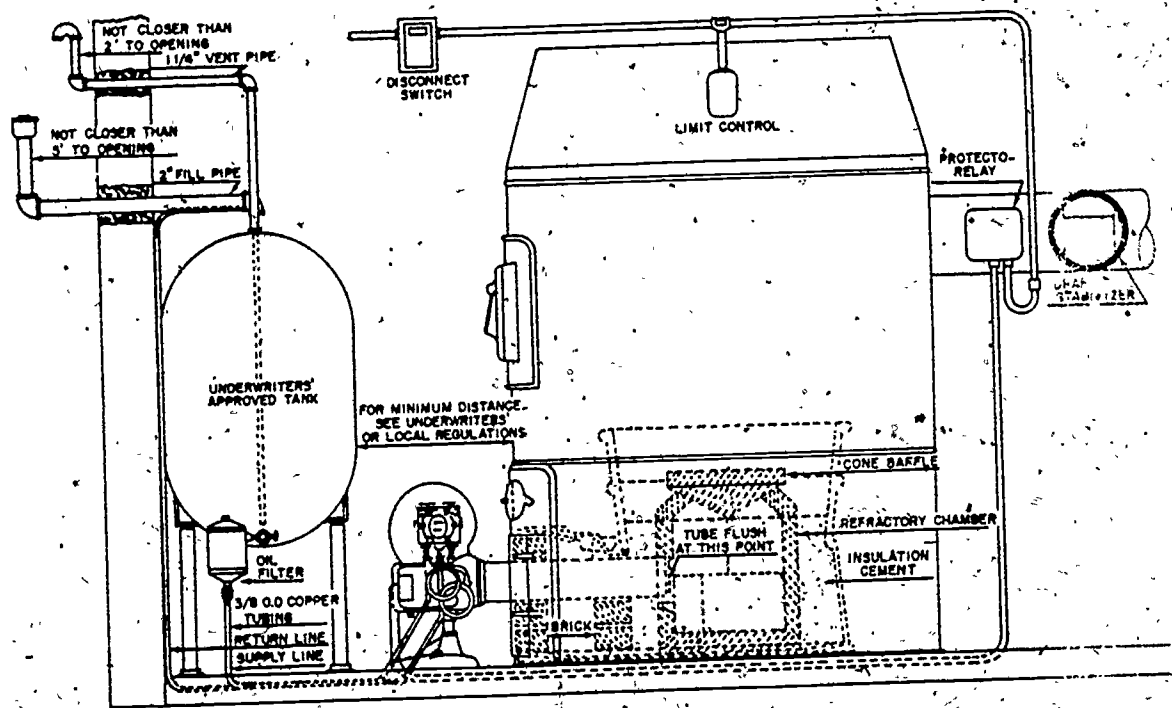


Figure 5-12. A double-pipe, gravity-feed forced return oil supply system.

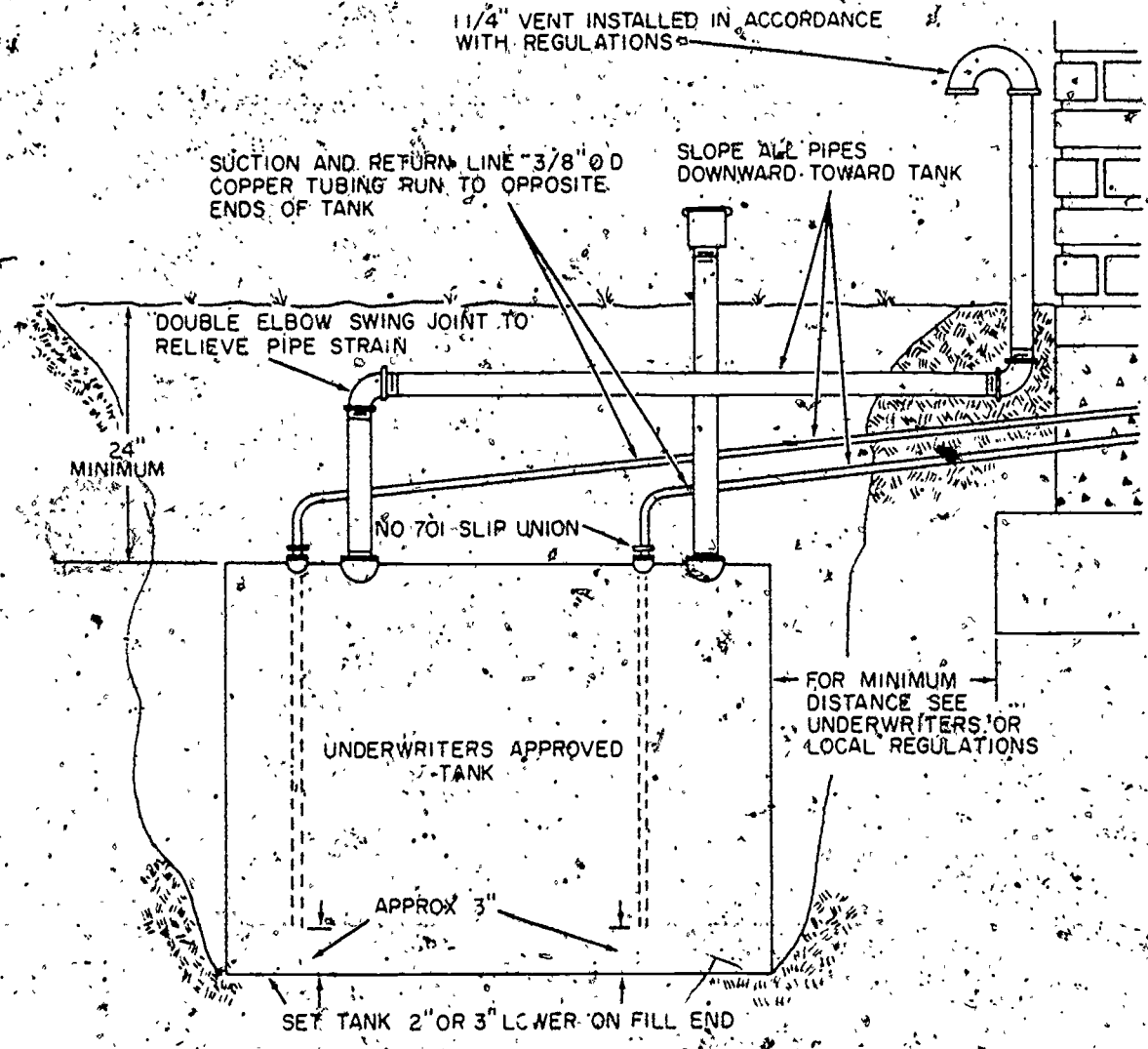


Figure 5-13. A double-pipe, forced-feed gravity return oil supply system.

3. Identify the four fuel oil supply systems.

completely informed of the danger involved and the need for strict observance of all safety rules. Explosion and fire, the presence of toxic liquids, vapors, or dusts, excess fuel vapors and oxygen deficiency, and physical hazards are the principal dangers of tank cleaning operations.

278. State requirements for maintaining fuel oil storage tanks.

Three conditions must exist to cause fire or explosion; fuel vapors, oxygen, and source of ignition. While it is almost impossible to eliminate the first two conditions, particularly at the start of a tank cleaning job, the third can be removed completely. All sources of ignition will be prohibited near tanks as long as any fuel vapors are present. No work on fuel tanks will be started during electrical storms or when one is nearby, or when wind conditions are such that fuel vapors might be carried into hazardous areas. Personnel will take special care not to carry matches, lighters, or other potential ignition sources into empty

An empty fuel oil storage tank should never be entered by personnel without permission and instructions from the proper authority. It is seldom necessary to clean a fuel oil tank until the sludge becomes excessive; the interior of the tank becomes excessively corroded, or the tank has to be repaired. When fuel oil tanks are cleaned, certain safety precautions must be complied with and certain methods followed. Personnel engaged in cleaning fuel tanks will be

fuel tanks during cleaning or repair operations.

All personnel engaged in cleaning or inspecting bulk storage tanks will observe all existing safety measures pertaining to this hazardous operation. Any man entering an empty tank will wear supplied air respirator equipment containing a speaking diaphragm to provide effective communications between workers within and without the tank. The equipment will be used until all vapor producing sediment has been removed from the tank and the air is free of toxic materials. Care will be taken to keep protective equipment in good working order at all times. Workmen entering tanks will wear clean clothing from the skin out, covered by white coveralls. Suitable, first-quality protective gloves and boots will be worn. Work clothing which becomes soaked with sludge or fuel will be taken off immediately and the worker will quickly bathe and put on fresh clothing before returning to the job. At the end of the day, work clothes will be removed for laundering, and fresh clothes will be put on the next day. All persons engaged in interior tank operations will bathe at the end of each job and immediately after each day's work. Breathing apparatus, boots, gloves, and tools will be cleaned at the end of each day and after any job is completed.

Sludge which has been removed from a tank will be kept wet until it can be buried in a safe location.

Anytime a bulk storage tank must be entered for inspection, cleaning, or repairs, the work will be approved by the major command having jurisdiction. The installation Liquid Fuel Facilities Engineer and the Industrial Hygiene Engineer, or their representatives will supervise the operations, regardless of whether the work is being done by Air Force personnel or qualified contractors. All persons who enter tanks will be in good physical condition. Colds, fatigue, overheating, or poor health will only add to the already present personnel hazards. No person with a punctured ear drum will be allowed to enter fuel tanks; the vapor-laden air may be drawn through the injury and into the body. As previously stated, all persons working inside fuel tanks will wear clean clothing of the proper type and specified protective equipment. Responsible personnel will be stationed outside the tank to keep a careful watch on those inside.

All tank cleaning operations will be conducted according to existing Air Force regulations and directives. Approved explosion-proof equipment will be used inside bulk fuel storage tanks.

The fuel oil supply lines should be checked for leaks by starting each pump in succession. This inspection should include the nuts on all valves, strainer caps, plugs and caps on air chambers, pump shaft packing, storage tank connections and fittings, all exposed piping, and controls. The pumps should be inspected for vibration and noise, and their packing should be replaced as required. All of the strainers should be cleaned at the recommended intervals by using steam, hot water, or solvent. When air pressure is used, you should be careful not to damage the strainer. The valves in the system must be inspected for proper operation and must be lubricated as required.

Any unusual condition or evidence of abuse of the fuel oil supply system should be reported at the time that it is first noticed.

Exercises (278):

1. Highly qualified tank maintenance contractors are employed to perform maintenance on Air Force fuel tanks at McSample AFB. It is mandatory for other agencies to be involved. Who are they?
2. Why is it necessary that a clean body plus clean clothes be maintained in cleaning fuel oil storage tanks?

279. Specify the factors involved in fuel requirements computations and compute annual fuel requirements from given information.

The fuel requirements to fire all of the heating units, regardless of type, are computed each year. When the base has been in operation for some time, the fuel requirements estimated for the coming year are determined on the basis of past fuel consumption. The fuel requirements for a new base, or for use in justifying changes in the fuel requirements at an old base, are determined by using a formula. The general formula for estimating fuel requirements is as follows:

Annual quantity of units of fuel

$$= \frac{(\text{Btu capacity of equip}) \times (24) \times (\text{degree days})}{(\text{Temp. differential}) \times (\text{efficiency}) \times (\text{Btu of fuel})}$$

The Btu capacity of the equipment, per hour, is usually found on the nameplate attached to



the equipment, if not, the manufacturer can furnish the information. The altitude of the base is a factor to be considered, because the output is generally given for sea level. Five percent should be deducted from the Btu capacity for each 1,000 feet of elevation. For example, a furnace having a 100,000-Btu output at sea level is reduced to a 75,000-Btu output at the 5,000-foot elevation. Because a heating unit is in continuous operation, the 24-hour element is included in the formula.

The term "degree days" refers to the difference between the mean temperature for the day and 65° F. For example, if the mean temperature for the day is 50° F., you subtract 50 from 65 and get the result of 15 degree days for that 24-hour period. The number of degree days is totaled for the month and for the year. In the formula, the number of degree days for the year is used. This figure can be obtained from the local weather bureau.

Temperature differential is the difference between the desired inside design temperature and the outside design temperature. The design temperatures are those established as the standard for use in planning. The desired inside design temperature is usually taken as 70° F. However, there are locations where this temperature is increased; for some buildings, depending on their usage, the design temperature may be less than 70°. The outside design temperature may be found in various heating handbooks. When these are not available, you use the average daily mean temperature during the coldest days of record.

The efficiency of the heating unit will be the value given in AFR 91-7, *Heating*. Values are quoted for hand-fired, coal-burning, and stoker-fired furnaces, and for gas- and oil-fired equipment as well.

The Btu content of the fuel is obtained from each supplier. Values quoted in AFR 91-7 may be used as a check, or when no other values are available. The Btu content of coal is given in Btu per pound, oil in Btu per gallon, and gas in Btu per cubic foot.

Hand-Fired Coal-Burning Furnaces. Using the general formula and substituting numerical values from the example which follows, the result becomes:

$$\frac{75,000 \times 24 \times 7,562}{90 \times 0.50 \times 20,000,000} = \frac{13,611,600,000}{900,000,000}$$

= 15.1 tons of coal

This is the yearly fuel requirement for one coal-burning furnace having a 75,000-Btu output per hour. There are 7,562 degree days at McSample AFB. The outside design

temperature at McSample AFB is -20° F.; the temperature differential is 90°, the difference between 70 and -20. The efficiency of a hand-fired furnace, as given in AFR 91-7, is 50 percent. The coal has a Btu content of 10,000 Btu's per pound. Therefore, a ton of this coal is equivalent to 10,000 Btu's times 2,000 pounds, or 20,000,000 Btu's. The total amount of coal for the year, as required for all buildings having furnaces of this capacity, can be obtained by multiplying 15.1 by the number of buildings.

Stoker-Fired Furnaces. For a stoker-fired furnace, use the same formula and substitute the same values as in the previous example, except the efficiency figure. Change it to 65 percent, which is the efficiency of a stoker-fired furnace. The result becomes:

$$\frac{13,611,600,000}{1,170,000,000}$$

= 11.63 tons of coal per stoker-fired furnace

Oil-Fired Furnaces. The same formula applies to oil-fired furnaces. However, in this application, you must substitute the Btu content of 1 gallon of fuel oil for that of 1 pound of coal. If No. 2 fuel oil is used and the Btu output of the furnace is 156,000 Btu's, the result from the formula becomes:

$$\frac{156,000 \times 24 \times 7,562}{90 \times 0.65 \times 138,000} = \frac{28,312,128,000}{8,073,000}$$

= 3,507 gallons of oil

The unit of measure for oil is the standard barrel, which contains 42 gallons. Therefore, 3,507 gallons divided by 42 equals 83.5 barrels. This is the amount of oil required for 1 year for one furnace of the specifications used in the formula.

Gas-Fired Furnaces. Here again, the same formula is used for gas-fired furnaces. It is necessary, however, for you to substitute the Btu content of 1 cubic foot of gas (800) for that of 1 pound of coal and use the same capacity of furnace as that used in the previous example. The result from the formula becomes:

$$\frac{156,000 \times 24 \times 7,562}{90 \times 0.65 \times 800} = \frac{28,312,128,000}{46,800}$$

= 604,960 cubic feet of gas

The standard reporting unit for gas is the therm. The following formula is used to convert cubic feet of gas to therms:

$$\frac{(\text{Cu ft of gas}) \times (\text{Btu per cu ft})}{100,000 \text{ Btu's}} = \frac{604,960 \times 800}{100,000}$$

= 4,839.68 therms of gas

Exercises (279):

1. What Air Force publication gives the efficiency of a heating unit?

2. How much more efficient should a stoker-fired furnace be than a hand-fired furnace?

3. How often are fuel requirements computed for heating units?

4. What is the meaning of the term "temperature differential"?

5. What is the standard unit of measure for oil?

6. How many gallons in the standard barrel?

7. Compute annual fuel requirements by using the appropriate formula and the following factors.

a. Stoker-fired unit—Btu capacity 80,000; 24-hour operation: 7,500 degree days; outside temperature - 10° F; Btu of fuel 20,000,000.

b. Gas-fired unit—Btu capacity 156,000; 24-hour operation: 7,500 degree days; outside temperature - 10° F. Btu of fuel, 1000.

8. What is the standard measure of gas?

9. In computing fuel requirements, the Btu capacity of a heating unit with an output of 200,000 Btu's is converted to what Btu output at 10,000 feet of elevation?

5-3. Coal Inspection and Sampling

Coal inspection insures that the coal supplier complies with the coal contract specifications. Coal sampling is an important

feature in determining the successful and satisfactory application of the specification method of purchasing coal.

280. Identify the types of inspections used on coal shipments.

Consistent checking on the condition of coal shipments as received by following a thorough inspection procedure for each unit (such as carload, truckload, or bargeload), is essential to:

a. Determine whether the shipment meets procurement specifications.

b. Provide supporting evidence for a price adjustment claim if coal does not completely meet specifications, but can be used with reduction in combustion efficiency and/or increased handling costs.

c. Support a demand for rejection of shipment if the coal is unacceptable.

Each coal shipment will be subjected to a thorough visual inspection by civil engineer personnel before the coal is unloaded to determine that:

a. Coal is reasonably free from slate, bone, sulfur balls, dirt, and other characteristic impurities or foreign material, including excessive moisture in truck-delivered coal.

b. Coal is properly prepared and reasonably free from fines and from undersize or oversize coal.

c. There is no evidence of loss or theft in transit.

d. Certified weigh bills are furnished for truck deliveries.

Exercises (280):

1. Before a coal shipment is unloaded, after it arrives at its destination, what type of inspection must be accomplished?

2. Why is a coal shipment visually inspected?

281. Specify factors involved in inspecting a coal shipment.

The duty of making a visual inspection of all coal shipments received at a given installation should be assigned to a responsible and reliable person (Civil Engineer Personnel) whose tour of duty is not likely to

COAL RECEIPT

CONTRACTOR LOGAN & KANAWHA CO	NAME OF MINE(S) BOONE No. 3	SHIPPING POINT MANOCO W VA	CONTRACT NO. DSA-600-11233
RATE OF SHIPMENT 2250 TONS/MONTH MAX	TYPE OF COAL (B11/SHD B11/A11H) BITUMINOUS	SIZE 1 1/4" x 0	TOTAL NO. OF TONS ORDERED 17.500
			SHIP NO 5

RECORD OF SHIPMENTS

DATE OF SHIPMENT	CAR INITIAL AND NO OR TRUCK TICKET NO	AF TRUCK NO	NAME OF MINE	SIZE	TYPE OF COAL (B11/SHD B11/A11H)	DATE		WEIGHT (LBS)	BALANCE DUE
						RECEIVED	UNLOADED		
3 JAN 66	PRR 47 X 329		BOONE No 3	1 1/4" x 0	BIT	7 JAN	8 JAN	120,000	17440T
3 JAN	LV 47312AG		BOONE No 3	1 1/4" x 0	"	7 JAN	8 JAN	116,000	17382T
4 JAN	C10 674 X 3		BOONE No 3	1 1/4" x 0	"	8 JAN	8 JAN	128,000	17318T

Figure 5-14.



change frequently. The experience and judgment of the inspector is most important because the visual inspection procedure must be simple, thorough, and must take a minimum of time. He must also be thoroughly familiar with the provisions and requirements of the coal contracts.

To make a visual inspection of a carload (or truckload) of coal, the entire top of the car must be examined closely. Each load of coal received should be walked and the size and composition observed.

In inspecting coal to determine that it is reasonably free from impurities, the inspector must rely on his knowledge of the appearance of previous shipments. The relative condition of any carload must be established by comparison with the average condition of previous carload shipments from the same source.

The inspector should collect a sample for testing if it appears that either of the following conditions exists: that (1) double screened coal exceeds the top size or fails to meet the minimum bottom size called for in purchase specifications; or that (2) single-screened coal (screenings, nut and slack mixtures, and the like) exceeds the top size specified. If the purchase specifications include a definite size consist, they will indicate the minimum percentage of coal that will be retained on, and the maximum percentage that will pass through the screen sizes listed. If, after visual inspection, the inspector believes that a coal shipment does not conform to the size consist specified, he should collect a sample for testing and determine conformance with the specifications before unloading.

Each car of coal should be inspected to determine whether the car is loaded to full visible capacity. Loss in transit can occur if hopper or bottom doors are not entirely closed before loading at the mine; if doors open in transit; if holes in bottom or sides of cars are not patched at the mine before loading; or if patches work loose from holes. Ordinarily, loss in transit can be detected by depression in the contour of the coal above or near holes or openings in car. The car is examined immediately and a record made of all open or partially open doors, holes in bottom or sides, or other conditions that permit leakage of coal in transit. Usually, theft occurs in cold weather at points of interchange where loaded cars stand on railroad sidings for a day or two, especially overnight. It can be detected by the disturbed or irregular appearance of the coal at the top of the car. Record is made on AF Form 97

(fig. 5-14) if the contents of the car appear to have been disturbed. Verification of weight of shipment should be obtained before unloading.

Exercises (281):

1. Who should be assigned the duty of accomplishing the visual inspections of coal shipments?
2. An apparent loss of coal due to theft is recorded on what form?
3. How should a load of coal be inspected?

282. Identify pertinent facts involved with a coal sample.

Air Force installations use thousands of tons of coal each year. To check the coal received at an installation, samples must be collected and prepared in strict accordance with methods described in AF Manual 85-15, *Coal Handling*. Whether the coal to be sampled consists of a few tons or several hundred, gross samples must be taken in the amounts indicated in the sampling procedure. The coal sample must be crushed, mixed, and reduced to the proper size for laboratory testing. The equipment used (shovel, riffle buckets, crusher, etc.) should be in good condition and conform to Bureau of Mines criteria. For collecting the increments of the sample, a coal shovel or grain scoop of large enough capacity to hold 10-12 pounds of coal without overloading to the spillage point should be used. The riffle bucket should have 20 spaces, each 3/4" wide, with half the spaces going to waste, and half going into the bucket for "save." The riffles should be examined for tightness to assure that there is no possibility of leakage from one slot to another or to the side opposite of that intended. Personnel who are certified as qualified to sample coal by approved methods should be available at each Air Force installation that is within the continental United States and which operates equipment burning 500 tons of coal or more a year. Only personnel certified by the appropriate Air Force command in agreement with AFR 91-7 may collect and prepare coal

192

UNITED STATES
DEPARTMENT OF THE INTERIOR
BUREAU OF MINES

Coal delivered to Fairchild Air Force Base, Fairchild, Washington
(Name and address of institution receiving coal)

Can No. 270 (From bottom of cans) Sample No. IAF
(Begin No. 1 for each contract, run consecutively)

Tons 51.0 (Represented by this sample) Coal Bituminous 1-5/8" x 0
(Kind and size)

Contract No. N424s-759 No. Item 8
(Order number or lot and item number)

Dates of delivery 7 - 21 - 54 Date of mailing sample 22 July 1954

Name of contractor Continental Con. Company

Shipping point Huawatha, Utah Mine name King
(Obtain from bill of lading)

Car Nos. and initials U. C. R. 21478

Remarks

ORIGINAL 16-42943-1 Sampler No. SAC 5 Signed JOHN DOE

Figure 5-15.

samples. The sampler's signature and certification number must appear on the Bureau of Mines, Form 6-220 (fig. 5-15) accompanying each sample sent to the Bureau, and his certification may be cancelled if his performance becomes unsatisfactory. The assistance of Air Force major command heating engineers should be requested when needed.

The basic steps in sampling are given below.

Time of Sampling. Whenever possible, take the sample while the coal is in motion, that is, during the loading or unloading. When this is not possible, top sampling may be employed. *When it is necessary to employ top sampling, it shall be stated in the report that top sampling was employed.* Do not collect samples from the top or sides or piles in storage areas, as samples so collected are unreliable.

Collection of Gross Samples. Use a shovel or other suitable receptacle for taking equal portions or increments to make up the gross sample. Not less than the stated number of increments must be evenly distributed from the entire quantity of coal sampled, and the increments must be about equal in weight. A complete cross section of a stream or flow of coal in motion is generally most representative. Collect increments for the

sample within a period not exceeding two weeks. Collect the increments regularly and systematically, so that the entire consignment will be represented proportionately in the gross sample. Collect each increment by passing the sampling instrument through a stream of coal or digging into the top of a conveyance with the same motion and requiring the same interval to complete the motion. When collecting increments from a falling stream of coal, the increment should be taken from the full width and thickness of the stream. If it is impractical to collect increments from the full width and thickness of the stream, increments shall be systematically collected from all portions of the stream. The stream should be entered from the opposite side on alternate cuts. The gross sample should contain the same proportion of lump coal, fine coal, and impurities as the coal sampled. When coal is extremely lumpy, the lumps shall be broken before the increments are collected. In such instances the proportion of lump that should be included in the gross shall be estimated, and a constant portion shall be included in the gross sample.

Size of Gross Sample. Use the weight of gross sample listed in figure 5-16. Whether the quantity of coal sampled is 1 ton, 500 tons,

	Maximum size of coal, inches			
	3/4" 3"	3"	8"	Plus, 8"
Minimum number of increments	50	100	50	50
Minimum weight of increments--pounds	10	10	20	30
Minimum weight of gross sample--pounds	500	1000	1000	1500

Figure 5-16 Size of gross sample

or more, the need for the gross sample to be of the weight stated is the same. In some instances, due to the flow of coal, its size, or the distribution of impurities, it may be impracticable to collect increments of the minimum weight specified in figure 5-16. It will then be necessary to collect increments of greater weights, resulting in an increased weight of the gross sample.

Quantity Represented by a Gross Sample. A gross sample shall not represent more than 1000 tons. Because the number of tons, within the above limits, represented by a single sample will vary for each consignment or shipment, consider each sample individually. For example, a shipment of 1,000 tons (20 railroad cars of 50 tons each) may be represented by 1 gross sample of the weight specified in figure 5-16, if properly collected. If a shipment consists of coal from several mines, take a separate gross sample to represent each mine. Store the gross sample of coal delivered under each contract in separate containers with an AF Form 119, Coal Sample Identification, attached to each container. The sampler must determine the number of gross samples desired, or the tonnage of the coal each sample is to represent.

Storage of Gross Sample. As the increments that make up the gross sample are collected, deposit them in a suitable receptacle, such as a wooden bin or metal can, equipped with a tightly fitting lid, until the gross sample is completed. Keep sample receptacles closed and cool to avoid evaporation of moisture and possible contamination of the sample. Inspect the sample receptacles each time before using and clean them thoroughly to remove any foreign matter that may be in them.

Truckload Sampling. Collect increments from each truck as the coal is being unloaded. The increments collected from each truck will depend on the number and weight of the loads that a gross sample is to represent. If the coal is unloaded by shovel, take the increments as described above. For dump trucks take the increments as the coal flows from the truck, being careful, however, not to take increments from the very first or last coal running.

Carload Sampling. In sampling coal from hopper bottom cars, increments may be taken from the stream of coal being discharged, if care is used not to collect portions of the first or last spilling from the car. After determination is made of the number of increments to be taken from the car, decision should be made as to the location for collecting each increment. The location should be planned so that increments are taken from each side, and the center (center of track position) of each hopper and should alternate right side, left side, center, etc. Because of the suddenness with which coal may drop out of a railroad car and because of the momentum of the rapidly falling lumps, collection of a satisfactory sample by attempting to catch shovelfuls may be impossible. If so, it may be necessary to collect shovelfuls of coal that have overflowed on the pier, the trestle deck, or the sides of pockets. If beams 10 to 12 inches wide span the pockets immediately under the car, a fairly satisfactory sample can often be collected in shovelfuls from the coal lodging on the beams, care being taken to assure that the beams are clean before coal is dumped.

In sampling coal being unloaded by hand from cars, take the increments that make up



the gross sample at regular intervals. Workmen unloading coal usually begin at one end of car and shovel the coal out to the bottom to facilitate shoveling from the floor. As a result, the load is exposed from top to bottom, and an excellent opportunity is afforded for taking increments for the sample from different places in the face exposed as unloading progresses, and it is easy to obtain a final sample composed of increments from all parts of the load from top to bottom and from end to end.

In sampling, when the railroad car is unloaded with a grab bucket in equal quantities and at frequent and regular intervals. The increments (shovelful) should be collected from alternate sides and corners of the grab bucket.

Ship or Barge Sampling. In sampling a ship or barge, as in sampling a railroad car, take portions of coal in equal quantities and at frequent and regular intervals while coal is being unloaded, so as to represent proportionate parts of the whole consignment. If the coal is unloaded by grab buckets or into barrows or coal-conveying equipment, increments usually can be advantageously collected at regular intervals from the buckets, barrows or equipment. The various increments (shovelfull) should be collected from alternate sides and corners of the grab bucket.

Top Sampling. Where possible, take the sample during loading or unloading. In a few rare instances, when there are no facilities for sampling the coal in motion, it may be necessary to take samples from the top of conveyances. However, this top sampling should be employed only when it is physically impossible to sample the coal in motion during unloading. Where "top sampling" cannot be avoided, distribute the required number of increments evenly over the whole number of railroad cars, trucks, or barges.

Dig holes as deep and narrow as possible, but not less than 18 inches in depth, at equal distances on the diagonal line from the corners of the vehicle. The position of the equally spaced sampling holes shall be varied along the diagonals from conveyance to conveyance as much as circumstances permit. In some instances this may be accomplished by sampling along alternate diagonals of succeeding conveyances.

Exercises (282):

1. How much coal is collected for a proper gross sample?

194

2. Who has responsibility for the accuracy of a coal sample?

3. Why is it necessary to store gross coal samples in clean, airtight containers?

283. State some of the steps in preparing a coal sample.

In preparation of a gross coal sample, systematically crush, mix, and reduce the gross sample in quantity for convenient transmittal to the laboratory immediately after it has been collected and prepared. The sample should be crushed and reduced by mechanical preparation. Take care to prevent loss of coal or accidental admixture of foreign material.

When possible install mechanical crushers that will break the coal to $\frac{1}{16}$ -inch or 4-mesh sieve size, and riffle buckets for reducing samples. Their use saves labor and time and tends to eliminate possible errors by the sampler, thus producing more accurate results. Equip the crushers with a "riffle splitter" that divides the coal into two equal parts on its exit from the crusher. This splitter at the bottom of the crusher should have 12 spaces, each $\frac{3}{4}$ inches wide with half the spaces discharging to the front and half to the rear. The riffle spaces should be such that there is no leakage between the spaces, or possibility of leakage to the side opposite that intended. The coal through the crusher should be caught in a container at the front, and one at the rear. The coal from the crusher does not always evenly divide between front and rear discharge of this riffle splitter. Therefore, the discharge saved for the sample should be alternated between front and rear. The crusher should not be set up with a permanent reject side. Special care should be taken to assure that the crusher and the riffle splitter are clean before crushing the sample.

After the gross sample is obtained, run the entire amount through the crusher. There must be no particles of coal larger than about $\frac{3}{16}$ inch; that is, all coal leaving the crusher on the first crushing should pass through a No. 4 screen. This can usually be judged visually. If the coal is not crushed to this size, run the entire sample through the crusher again. Ordinarily this second crushing of the entire sample will not be found necessary.

Accumulate half. After the first run through the crusher, run the retained half through the crusher again, and repeat this until about 65 pounds remains, or enough to fill a standard Bureau of Mines riffle bucket.

Next, hand riffle the 65 pound sample down to about 3 pounds, or enough to fill the standard Bureau of Mines coal sampling shipping container. The buckets are used in pairs, the coal from one bucket being poured over the riffler of the companion bucket, thus eliminating half the quantity being poured and retaining the other half. In using riffle buckets to reduce the crushed sample to the final quantity (one Bureau of Mines coal sample shipping container), all save portion of the final split must be put in the sample can. If all of this save portion amounts to two-thirds of a can full, or to a completely filled can, or to any quantity between these two points, sample can be submitted for analysis as is (can need not be full). If the save portion of the final split is more than a can full, the portion remaining after the can is filled, is *not discarded*, but the portion of the sample in the can is combined with it once again. Then this combined portion is riffled and both halves are saved. One half is put into the sample can. The other half is then riffled one more time, with the save portion of this split being put into the sample can. The can is now ready to be submitted for analysis. None of the coal from the riffle bucket should be permitted to spill when pouring into the sample can. Spillage can easily be prevented by cutting a hole in a cap for the sample can, placing a wide mouth funnel in the hole, and soldering the funnel to the cap.

In packing the sample, pour the sample directly from the riffle bucket into the metal container, which carries an identifying number on the bottom. The can shall be from two-thirds full to completely full. Screw the top on tightly, checking to see that the rubber gasket provided for each top is in place. Secure the top further by placing at least four strips of friction or scotch tape across the top, extending 2 inches down the sides of the can. Reinforce the side strips with two more rounds of tape around the sides of the can. Wrap the can thoroughly with heavy paper and tie it securely. At least 12 cans should be stocked at installations where frequent sampling is required. Cans—in lots of 4, 16, 24, or 48—are available on request from the Bureau of Mines, Pittsburgh, Pennsylvania. Duplicate samples will not be stored at the installation.

Exercises (283):

1. You have finished preparing a coal sample to be shipped to the Bureau of Mines. Approximately how much coal will you ship them for one sample?
2. What should a coal crusher be equipped with to separate the sampled coal into two equal parts?

5-4. Safety Precautions

Safety is one of the most important factors confronting a heating man today. Every act he performs must be in a safety-oriented manner. From walking to from the job, to unloading fuel with the finest mechanical equipment, a heating man must be concerned about the potential dangers that surround him.

284. Identify the effects of heat on fuels and list safety precautions required as a result of heating.

Temperature or heat has certain effects on the various fuels. These effects are explained below.

Coal. Coal storage piles and heat can be very dangerous because of the possibility of spontaneous combustion. Piles should be inspected for excess heat at least once a week. Evidence of spontaneous combustion is ordinarily discovered by steam or coal gas odors escaping from the coal pile.

To make a complete inspection of the coal piles, 3/4-inch metal pipes, closed at the bottom and reaching nearly to the base of the coal, are placed in the coal pile approximately every 25 feet. With this arrangement, thermometers can be lowered into the piles for checking the temperature of the coal pile at that point. The pipe should not be removed once it has been inserted, because the hole left in the pile by the pipe aids in the generation of heat. If temperatures of the coal reach 120° F., the coal should be watched closely for any rapid rise in temperature; and provision should be made for immediate removal of the hotspot when the rise occurs. If the temperature rises to about 160° F. within a week, there is danger of spontaneous ignition and you should remove the hotspot immediately.

Another method of checking the heat within a coal pile is to insert metal rods, 1/4 inch to 1/2 inch in diameter into the coal nearly to the base of the piles approximately every 25 feet. They are withdrawn after they reach a constant temperature, which usually requires about 2 hours. If the inserted portion of the rod can be held in the hand at the hottest point, then there is little danger of ignition. However, if the rod is too hot to hold, you should remove the hotspot of coal immediately.

Oil. The pressure in a closed section of a system, pipe line, or hose increases rapidly with a substantial temperature rise, because fuel oils expand. Unless this excessive pressure is relieved, leakage or permanent damage to valves, meters, and other pieces of equipment can result. In a mechanical storage system, enough air space should remain in the tank at all times to allow for this expansion. You will find that air is forced from the vents when the temperature rises, and re-enters the tank when the temperature decreases. When sufficient airspace is not provided for expansion, the tank overflows as the oil expands, and creates a fire hazard. The tank vents are installed to allow air to leave and enter the tank as required. These vents must be kept clean to avoid damage to the supply system.

Gas and vaporized fuel oil heated to ignition temperature are combustible when mixed with the proper amounts of air. If ignition occurs inside a container or within a confined space, destructive pressures usually develop. Although fuel oil does not vaporize as easily as gasoline, the dangers caused by the accumulation of vapors in low areas or confined spaces are serious. Fuel oil vapors are heavier than air and tend to settle into pits and low areas, creating mixtures which are fire and explosion hazards. Fuel oil is lighter in weight than water and spreads over the surface of water. This condition also creates a fire hazard.

Gas. Heat in the form of a spark or flame will cause gas to explode, or start a fire at atmospheric pressure. A temperature rise also affects the pressure of stored LPG. The vapor pressure of propane, for example, at 60° F. is 92 psig; if the temperature rises to 100° F., the vapor pressure increases to 175 psig. This indicates that the pressure increases rapidly as the temperature rises. Proper containers with a high-pressure rating have to be used to provide a reasonable margin of safety.

Exercises (284):

1. What is normally the first indication that a coalpile is overheating?
2. You are making the weekly inspection of the coal storage area. You find that the temperature in one coalpile has risen to 165° F. since the last inspection. What should you do?
3. What happens when an oil tank is filled completely during cold weather and the weather suddenly becomes warm?
4. How does heat affect gas?
5. What is installed to prevent the overflow of oil from an underground storage tank?

285. Specify the proper method of checking for gas leaks.

Safety should be the main factor in any construction, maintenance or operation in connection with gas and its related equipment. Gas leaks in a confined, unventilated area can result in an explosion. A leak test should be performed on all equipment connections while the system is under pressure. A solution of soapy water is applied with a brush at each point when checking for gas leaks. A soap bubble will form at the joint if a gas leak exists. A lighted match or open flame should never be used to check for gas leaks, since the escaping gas is apt to ignite and cause an explosion and a fire.

Exercises (285):

1. How are gas leaks usually found?
2. How does a soap solution work in finding gas leaks?

191

286. Explain the proper dress required when loading and unloading fuels and state why protective clothing and equipment are important.

Many of the hazards encountered in fuel handling activities are difficult to control or eliminate, even though efforts are taken to safeguard each step of the operation.

In addition to the grave dangers of explosion and fire, there are hazards to personnel who come in contact with highly toxic or corrosive fuels and solid fuels.

The importance of personal protective clothing and equipment to safeguard the health of persons engaged in this work cannot be over emphasized.

All personnel involved in fuel handling will wear the protective clothing and equipment required by the nature of the operation and listed in applicable Air Force directives.

Hard hats, respirators, face shields, gloves, and safety shoes are some of the required clothing necessary when handling fuels. In addition loose clothing (ties, open sleeves, etc.), rings, watches, and necklaces will not be worn when around moving machinery involved in fuel loading or unloading.

Exercises (286):

1. Why are open hanging sleeves prohibited when working around moving machinery?
2. Why are protective clothing and equipment important to personnel involved in fuel handling?

287. Identify the proper unloading factors and fundamentals for fuels.

Coal. The loading and unloading methods for coal are too numerous to cover each in detail. However, the fundamentals of efficient and economical unloading and storage of coal are:

- a. Intelligent and formulated plan of storage.
- b. Experienced and well-trained personnel.
- c. Control storage areas of sufficient capacity and proper construction.
- d. Adequate coal handling equipment properly maintained and operated.
- e. Establishment and maintenance of coalyard records.

f. Requisitions specifying proper coal cars that can be adapted easily to unloading with available coal handling equipment.

g. Careful preparation of delivery schedules on coal requisitions in relation to consumption rates and available storage space.

h. Knowledge of characteristics of coal to be received.

i. Interest and effort commensurate with the importance of solid fuels and money invested.

Oil. When unloading or drawing fuel, you should take every precaution to insure that no static electricity exists in the vicinity of this operation. A spark caused by static electricity can cause an explosion that may result in death or serious injury to you or your fellow workers and damage or destroy Government property. The danger of fire or explosion can be minimized by making sure that the railroad car, the fuel oil truck or trailer, and the fuel tank are grounded while the fuel transfer is being made.

Gas. Since natural gas is normally supplied through gas supply lines from the gas companies to the users, there is no loading or unloading procedure. However there are unloading procedures involved with LPG.

When unloading LPG from a railroad tank car, spot the car in the proper place, set the brakes, and block the wheels. Place signs reading "STOP - Tank Car Connected" in the center of the tracks 25 feet from each end of the car. Approximately 5 feet ahead of the stop sign, at the end of the car nearest the carrier tracks, place a derail between the car and the tracks. Using special unloading hoses, connect the liquid loading header to the transportation tank liquid line, and the vapor header to the vapor connection. Similar procedures are used when a storage tank is being filled from a tank truck.

Open the necessary filling and unloading system valves and start the transfer pumps. Vapor pressure between the storage and transfer tank is equalized through the vapor connections, and the pump transfers the liquid to the storage tank. Never fill the storage tank above the 90-percent level. The remaining 10 percent allows for any expansion which may take place.

Exercises (288):

1. What is one of the main factors involved in unloading fuel oil?

2. Give a summary of the fundamentals of coal unloading.

288. State how static electricity is created and controlled.

Static Electricity. Static electricity is a constant source of danger, particularly when generated near fuels or flammable vapors. It has been responsible for starting many fires which have resulted in extensive property damage and personnel injuries. Static electricity is created primarily by the contact and separation of two unlike substances or by almost any sort of motion of persons or material. High static electrical charges are created by persons walking, by moving rubber-tired vehicles, when liquid drops through space, and when petroleum products are pumped through lines and hoses. Although static charges are usually short-lived, they will often produce sufficient heat to ignite flammable gases, vapors, dust, or other flash point materials, particularly during dry, cool weather.

While the generation of static electricity cannot be prevented, the sparking hazard can be effectively controlled by grounding,

198
bonding, or humidification. Grounding and bonding are particularly important in fueling operations, paint and dope shop work, aircraft and vehicle maintenance, ammunition handling, rocket and missile operations, compressed gas use, and in many other daily Air Force operations.

Static electricity is dangerous first, because it cannot be seen, and second, because its potential hazards are not commonly known. When the dangers associated with static electricity are fully understood by supervisory and operating personnel, they will readily recognize the need for implementing immediate and effective control measures. Since static electricity is generated primarily by bringing together and separating two unlike substances, or by motion of almost any description, the use of effective grounding and bonding measures will greatly reduce the static electrical hazard.

A drop of liquid falling through space can build up charges of 10,000 volts in a split second under proper conditions; it begins to spark or arc at about 300 volts; static charges of only 1,500 volts will ignite gasoline fumes; a person walking across a dry area creates many times the voltage needed to create a spark to ignite gasoline.

Grounding. Grounding is probably the most practical way to control static charges so

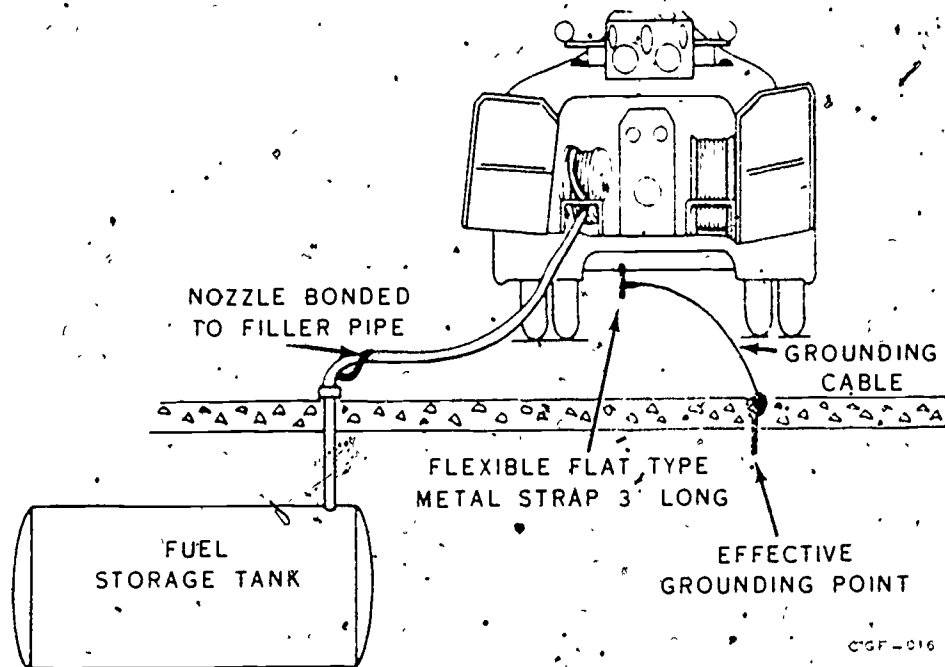


Figure 5-17. Grounding and bonding system for fueling a storage tank.

that they will easily flow to the ground. Through grounding, the static charges which build up within an object will be carried off harmlessly, neutralizing the difference in electrical potential. Specific grounding procedures, given in applicable Air Force directives, will be observed by operations personnel in all operations (fig. 5-17). Grounding connections will be made to clean, unpainted surfaces.

Bonding. Effective bonding will eliminate the differential in electrical charge potentials which may exist or be generated between two objects. By connecting the two objects with a bonding wire attached to clean, unpainted surfaces, a static electrical discharge cannot occur between these objects. Bonding is just as essential as grounding, and is invariably used together with static grounds. Although bonding will equalize the charge between two electrically connected objects, the objects themselves may still be highly charged. By connecting a ground wire to the bonded objects, this charge will be drained off without danger. Conductive greases and "V" belts on shaft pulleys are examples of effective bonding.

Exercises (288):

- 1 How is static electricity created?
2. How is static electricity controlled?
3. Bonding is almost always used with grounding procedures. What function, if any, does bonding contribute to static electricity control?

289. State sources of damage which can cause static grounds to malfunction.

Static bonding and grounding systems will be continuously inspected for defects. Because these systems are constantly exposed to weather, contamination, mechanical wear, climatic changes, and other sources of damage, they can easily become ineffective. All bonding and grounding systems will be maintained and inspected according to the standards outlined in the appropriate technical order (TO) and only the equipment

meeting these standards will be used. Grounding points and facilities meeting the specifications of this TO will be adequately marked according to existing provisions. When defective equipment is found, it will be taken out of service immediately, and the markings around defective grounding points will be obliterated to prevent their reuse.

Exercise (289):

1. What sources of damage can cause static ground systems to malfunction?

290. Cite the safety precautions that must be followed when performing duties with or near mechanical equipment.

Various items of safety have been covered in the previous learning objectives. We will now cover the safety procedures that are to be observed when performing duties with mechanical equipment.

Although accidents due to unguarded machinery occur less frequently than those with moving machine parts, they are generally severe and often result in permanent disability of the operator. Improved machine design, or the installation of mechanical safeguards, removes from the operator much of the dependence for safety. Two principles of machine guarding requiring careful consideration are power transmission machinery guarding, which includes all equipment from the prime mover to, but excluding, the point of operation; and point-of-operation guarding, the area where the actual work of the machine takes place. Applicable standards prescribed herein or as outlined by industrial practices will be consulted for detailed information on the use of machine guards.

When machinery and powered transmission equipment are not guarded as part of their design, suitable mechanical guards such as enclosures or barricades will be temporarily or permanently installed to eliminate the possibility of injury resulting from contact with moving parts or hazardous substances.

Machine controls will be conveniently located for the operator. In the use of all conveyor systems, stop switches will be installed at intervals not exceeding 100 feet and at lesser intervals where obstructions are located in the path of travel—that is, stop switches will be so located that they may be

reached without changing elevation of travel, to allow immediate shutdown in an emergency. Stop switches will *never* be made inaccessible by covering or blocking off. Power controls will be of a type that can be locked in the "off" position when repairs are necessary. Suitable identification signs will be posted at control switches. Machine operators will not leave machinery running unattended. For maximum safety, exposed shafting less than 8 feet above the floor will be completely enclosed in a stationary metal guard. All pulleys, belts, ropes, chain drives, gears, sprockets, chains, couplings, and clutches that are located less than eight feet above the floor or work area will be properly guarded.

Proper clothing, such as explained in learning objective 286 will be worn and be in suitable serviceable condition when personnel

are working around any type of mechanical equipment.

Exercises (290):

1. Give an example of a power transmission machinery item, used by a heating man.
2. What are two areas which require machine guarding?
3. When repairs are made on dangerous equipment operated by electrical means, what precautions should be taken to insure that the equipment will not accidentally start operating?

ANSWERS FOR EXERCISES

CHAPTER 1

Reference








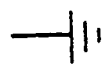
- 200 · 1 Elements are known as the building blocks of nature
- 200 · 2 Matter is composed of very small units called molecules, which are made up of atoms, which in turn are made up of particles called protons, neutrons, and electrons
- 200 · 3 Current flowing through a conductor is compared to water flowing through a pipe
- 200 · 4 Water is composed of two distinct elements, two parts of the element hydrogen (H₂) and one part of the element oxygen (O), expressed H₂O
- 200 · 5 Compounds can be separated only by chemical means, and a mixture can be separated by physical means
- 200 · 6 A molecule
- 200 · 7 Atoms.
- 200 · 8 Electrons moving or flowing through a conductor

- 201 · 1. Voltage is electrical pressure, electromotive force (EMF) and potential difference.
- 201 · 2. Heat, magnetism, chemical action, and physical force.
- 201 · 3 Magnetism is produced when current flows in a conductor.
- 201 · 4 By the cross-sectional area, the length, and the temperature.
- 201 · 5. The ohm.
- 202 · 1 Electrons moving in one direction through a conductor.
- 202 · 2. Electrons moving back and forth through a conductor at a specific interval.
- 203 · 1 $E = I \times R$ - volts equals current times resistance.
- 203 · 2. Ohm's law is used to compute voltage, current and resistance.
- 203 · 3 This law is for the quantities of a circuit, which is: one volt is the pressure required to force 1 ampere of current through a resistance of 1 ohm.
- 203 · 4. $I = E$ divided by R , which gives you 20 amperes.

- 204 · 1 The three basic circuits are series, parallel, and series-parallel.
- 204 · 2 A series circuit is defined as one in which the current has only one path to follow.
- 204 · 3 A parallel circuit allows electrical devices to be operated independently and at a decreased total resistance.

- 204 · 4 You would be required to use a series circuit when wiring electrical heating controls. All safety devices and controls must be wired in series
- 204 · 5 The lights would be wired in series circuit when one light fails to burn. All other lights fail to burn in that circuit because the circuit is broken

- 205 · 1 Electrical symbols are used when preparing electrical plans, wiring diagrams, and schematics
- 205 · 2. The symbol for an outlet is designated by a circle with a letter or added line to show its purpose
- 205 · 3 The purpose of using symbols is to show equipment and circuit components and as an aid in installing electrical circuits, tracing circuits, and locating malfunctions.
- 205 · 4. The electrical drawing that shows detailed wiring and component connections is a wiring diagram.
- 205 · 5. The purpose of wiring diagrams is to show how wires of a circuit connect electrical fixtures and other components.
- 205 · 6. a-4, b-5, c-6, d-7, e-3, f-1, g-2, and h-8.

- | | |
|--|--------------|
| a.  | 1. Voltmeter |
| b.  | 2. Switch |
| c.  | 3. Coil |
| d.  | 4. Motor |
| e.  | 5. Resistor |
| f.  | 6. Voltmeter |
| g.  | 7. Fuse |
| h.  | 8. Ground |

- 206 · 1. The purpose of meters is to aid in repairing, maintaining, and troubleshooting electrical circuits and components.

- 206 2 A self-excited meter operates from its own power source
- 206 3 The multimeter is composed of a voltmeter, ammeter, and the ohmmeter
- 206 4 Always short circuit the test leads in using the ohmmeter portion of the multimeter, and adjust the meter to zero to compensate for battery loss and internal resistance
- 206 5 You use the voltmeter portion of the multimeter to measure the electrical pressure
- 206 6 The voltmeter measures volts, ammeter measures amps, and the ohmmeter measures ohms
- 207 1 You look for loose connections and wires, abraded wires, and type of wiring
- 207 2 Problems are open circuits, short circuits, or grounds, which include, solid grounds, partial grounds and a floating ground
- 208 1 Fuses, circuit breakers and circuit protectors are all common protective devices
- 209 1 If fuses are making poor contact, air gets to the contact surface and heating of the fuse causes oxidation
- 209 2 If a fuse shows no means of being blown, a meter should be used to test its usability
- 209 3 Check all distribution panels, fuse panels, and circuit breakers for cleanliness, corrosion, and proper usage
- CHAPTER 2
- 210 1 A circuit is completed in a mercury-type switch when the mercury covers the contacts
- 210 2 The function of a control transformer is to step voltage down so that it can be used on different kinds of electrical controls.
- 210 3 The purpose of a control relay is to remotely control an electrical device, such as a motor or pump.
- 210 4 The contacts must open and close quickly to avoid excessive arcing across the points, resulting in burning the surfaces.
- 210 5 Switches, relays, control transformers, and magnetic starters.
- 211 1 A thermostat should be in a position to register the average ambient temperature. A good location is 4 or 5 feet from the floor on an inside wall.
- 211 2 You would install a hot water limit control, which is called an aquastat.
- 211 3. Most automatic controls respond to a temperature change, pressure change, or humidity
- 211 4. A primary control is an actuating device that operates the firing equipment in response to signals received from a thermostat or aquastat.
- 211 5 An immersion well
- 212 1. The most common safety controls are limit controls (aquastat) and combustion safeguards (stack switch, protectostat, photo-electric eye, and low-water cut-off)
- 212 2. All of the safety controls can and are used on a hot water boiler because they all perform different safety functions.
- 212 3. A stack switch.
- 213 1 The two settings on the pressure control are the cut in pressure and the differential pressure
- 213 2 The pressure control is tested by raising and lowering the pressure on the boiler to make sure that it operates the controlled devices properly
- 213 3 A siphon having its loop extending in the direction of the back and at a 90° angle to the front
- 213 4 Insuring that no pipe dope is permitted inside the control
- 214 1 The snap-action and mercury type are the most common
- 214 2 Switches respond to temperature change, pressure, or humidity
- 214 3 The thermostat switch
- 215 1 Recalibration would be necessary if a thermostat indicated more than 1% of variance from the test thermometer
- 215 2 Use a good grade of writing paper or a caling card, when cleaning control contacts
- 215 3 Only authorized and trained personnel
- 215 4 Set the thermostat above room temperature then check the operation of the aquastat by changing the setting and observing how the controlled equipment functions
- 216 1 A conductor is a single wire, whereas a cable is composed of many wires
- 216 2 You would be using size No 14, three-wire, duplex-rubberized moisture-resistant wire, which can be used in either wet or dry locations
- 216 3 Duplex wire consists of two insulated wires enclosed in a protective sheath or covering.
- 216 4 The covering determines the type of wire
- 216 5 You would be wiring an appliance
- 217 1 A "tap" splice is connecting one wire to a continuous wire
- 217 2. To make a tap splice (solid wire), remove approximately 1 2 inch of insulation from the continuous wire and about 3 inches from the tap wire. Tag the bare end, tap wire, over the continuous wire and make one wrap. Cross the tap wire, and make five close turns around the continuous wire. Cut off the excess.
- 217 3. Most safety controls have screw terminals so you would use the loop connection
- 217 4 Solder and tape after most splices
- 217 5. Only enough insulation is removed from a wire to make the connection — no more
- 218 1. A magnetic field is the area surrounding a magnet which attracts metal alloys containing iron
- 218 2 The molecular theory of magnetism is the theory that a magnet substance is composed of millions of tiny magnets
- 218 3. A temporary magnet is one made from soft iron
- 219 1. An electromagnet is an iron bar inset in a coil of wire, which is attached to a battery
- 219 2. The strength of an electromagnet is determined by the number of windings around the core, the material of the core, and the amount of current in the winding

- 220 - 1. A relay is a switching device.
- 220 - 2. A common relay, when energized, pulls down an armature. A solenoid itself moves an internal core.
- 220 - 3. The relay's function is to open or close an electrical circuit.
- 221 - 1. A relay switch consists of a moveable contactor, stationary contact, fixed core, solenoid coil, and a return spring.
- 221 - 2. Secure power. Remove retaining nut, coil jacket and coil, and all parts in need of repair. Use reverse procedures in replacement.
- 222 - 1. A defective transformer is troublesome and causes a lot of time to be wasted.
- 222 - 2. The transformer would probably be defective, because to have a reliable unit an unfaltering spark of at least 3/4 inch is necessary
- 223 - 1. Always make sure you have the correct mounting plate for any replacement transformer
- 223 - 2. You would consult the burner's specifications to obtain the correct type and size of transformer.
- 224 - 1. To remove a motor, first deenergize the power source and tag all wires and leads as you disconnect the unit from the power source. Remove motor from brackets, braces, or mounting plates. To replace a motor, reuse these steps, being sure to connect the correct leads and wires to the power source. Check motor for noise speed, vibrations, and temperature rise.
- 224 - 2. Recheck new V-belts 1 or 2 days after installation to insure the proper tension.
- 224 - 3. The requirements in replacing a motor are correct motor voltage, amperage, rpm, rotation, and shaft size, plus correct alinement and wiring connections.
- 225 - 1. To insure that the connections do not vibrate loose.
- 225 - 2. The nameplate usually shows a diagram for proper wiring.
- 225 - 3. Insure that all connections (at motor junction box, etc.) are secure and tight.
- 226 - 1. Equipment rooms must be kept locked to keep unauthorized personnel from tampering with the equipment.
- 226 - 2. Grounding systems are provided so that, in the event of a short circuit, the voltage is conducted to ground
- 226 - 3. If an item of jewelry becomes shorted between the conductors of a circuit, it can become red hot, resulting in severe burns.
- 226 - 4. Make sure you have the necessary protective equipment—rubber gloves, blankets, mats, and so on. Inspect equipment for defects before performing work
- 227 - 1. Make sure the circuit breaker is "locked" in the OFF position to prevent someone from accidentally energizing the circuit.
- 227 - 2. Always use handtools so that the working force is directed away from your body.
- 227 - 3. Air Force safety publications.

- 228 - 1. Electronics can be defined as the science dealing with the control of electron flow, especially by means of electron tubes.
- 228 - 2. All vacuum tubes have electron emission in which free electrons are forced to leave the surface of a conductor and enter the space around it.
- 228 - 3. All vacuum tubes must have two electrodes, a cathode, and an anode.
- 229 - 1. The components of an electronic control system are thermostats and a control panel consisting of a bridge circuit, amplifier, switching relays, and conductors.
- 229 - 2. The Wheatstone bridge is the nerve center of the electronic control system.
- 229 - 3. The component which starts motors and valves is the regulatory element (switching relays).
- 230 - 1. Dc voltmeters, multimeters, and oscilloscopes are used to test electronic control systems.
- 230 - 2. The oscilloscope is used to measure frequency, determine the amplitude of a voltage, and monitor the waveforms of voltages.
- 231 - 1. You would proceed to check for bad tubes, check to see if the bridge circuit or amplifier was faulty, and check for bad connections or improper voltage.
- 231 - 2. You would check for faulty bridge circuit, faulty amplifier, faulty plug-in, an open or short in the sensing element, or weak tubes.
- 232 - 1. The two electronic control system components that use flame controls are RA890F and the FP-2.
- 232 - 2. Removal of the RA890F consists of unscrewing 10 mounting screws and the replacing of a new control which is accomplished by screwing 10 mounting screws to the subbase.
- 232 - 3. The removal and replacement of the FP-2 system consists of plugging the control chassis into the housing and securing it by two thumb screws.
- 233 - 1. The basic maintenance fundamentals of the RA890F, is to follow the manufacturer's instructions, perform flame-failure checks, flame-current checks, and cleaning the detectors and contacts. For the FP-2 system, maintenance consists of cleaning contacts and rotating the units periodically to insure their usability
- 234 - 1. A sensing element
- 234 - 2. A controlled variable is that which is being controlled—such as air, temperature, humidity and pressure
- 234 - 3. NO stands for normally open which is a characteristic of a controlled device that automatically assumes the open position and requires control pressure to close. NC is normally closed and it is a characteristic of a controlled device that automatically assumes the closed position and requires control pressure to open
- 234 - 4. Controlled devices are valves and dampers
- 234 - 5. The terminology for a thermostat, humidistat or pressure controller is controller
- 234 - 6. The terms bleed and nonbleed refer to the



- manner in which certain pneumatic controllers operate.
- 235 - 1. A thermostat is a control device that senses the temperature of an individual space.
- 235 - 2. A room thermostat is direct acting, whereas a heating-cooling thermostat is both direct acting and reverse acting.
- 236 - 1. To adjust a pneumatic room thermostat, you first remove the capscrew and insert a test gage. Next, set the dial to the control point, set the adjusting screw to a set point, turn the dial to the desired temperature point, remove test gage and replace capscrew.
- 236 - 2. To adjust a heating-cooling thermostat, insert a test gage, set dial to ambient temperature, adjust the heating and adjusting screw to set point, turn dial to desired temperature point, and change previous air pressure of 15 psig to 19 psig. Recheck ambient temperature at sensing points, turn the cooling adjusting screw to set point, turn dial to set cooling range and remove test gage.
- 236 - 3. Always consult the manufacturer's instructions before any type of repair is attempted.

CHAPTER 3

- 237 - 1. A 100-foot length of standard weight black iron (uncoated) pipe would be needed.
- 238 - 1. A 1" fitting will fit a 12" piece of 1" threaded pipe.
- 238 - 2. Tees are used to pick up branch runs at 90° angles.
- 238 - 3. Unions are aids in removing or installing sections of pipe or equipment.
- 238 - 4. Nipples are lengths of pipe not exceeding 12" in length and threaded at both sides. There are close nipples, short nipples, and long nipples.
- 238 - 5. A bushing is used to reduce the size of an opening in a valve or fitting, and a bell reducer is used to make a reduction in a run of pipe.
- 239 - 1. The term "125 WSP" stands for 125 lbs of working steam pressure.
- 239 - 2. Gate valves may develop leaks at the valve seat, around the stuffing box, and at the body-bonnet joint.
- 239 - 3. A globe valve is used for regulating purposes.
- 239 - 4. Most check valves are marked to indicate the inlet opening or direction of flow.
- 239 - 5. The angle-globe valve is used on radiators and connectors.
- 239 - 6. Plug valve may be completely opened by a one-quarter turn; and they do not have soft packing, which tends to wear
- 240 - 1. The methods of measuring pipe are end-to-end, end-to-center, and center-to-center
- 240 - 2. The number of threads for a piece of 3/4" pipe is normally 14.
- 240 - 3. The center to-center measurement should be used when the pipe has a fitting screwed onto both ends.
- 240 - 4. Threads are identified by number per inch.
- 240 - 5. The number of threads per inch is determined by the pipe size.

- 241 - 1. Needed are one section of 1/2" black iron pipe (uncoated), one each union fitting, and one each nipple both in 1/2" size. Connect half of union to nipple and install nipple to gas valve. Use center-to-center measurement to arrive at correct length needed from union half to valve. Cut, ream, and thread pipe. Make connection.
- 241 - 2. The die sets have to be changed after completing threads on 2" pipe because the dies are of different sizes from 2" to 1"
- 241 - 3. A few safety precautions that should be observed are as follows: never consider threading pipe by power tools routine, always pay close attention to what you are doing, and never try to stop a pipe from shifting. Keep loose-fitting clothes away from moving parts and be electrically conscious.
- 241 - 4. The most likely cause is that one complete revolution was not made around the pipe to insure a complete cutting mark.
- 241 - 5. Rough cut threads are caused mainly from two things: the dies were not sharp or had nicks and were worn; or not enough threading oil was used, resulting in marring of threads.
- 242 - 1. The green identifies the thickest walled copper, and the yellow indicates the thinnest wall copper.
- 242 - 2. It is lightweight, easily transported, quickly installed, and lasts longer than steel or iron pipe.
- 242 - 3. The most probable cause for flattened places in copper tubing is that the proper methods of bending were not adhered to.
- 242 - 4. A blue color band represents type L copper tubing, a medium wall thickness which is recommended for interior applications.
- 243 - 1. The types of copper fittings you will normally find in the heating shop are flare, sweat, and compression, of which there are tees, elbows, reducers, valves and cocks, couplings, and adapters.
- 243 - 2. To change directions using copper tubing, elbows and tees are generally employed.
- 243 - 3. Adapters are used to make connections between copper and iron or steel pipe.
- 244 - 1. The common method of cutting copper tubing are, using a tubing cutter and using a hacksaw
- 244 - 2. Mark the tubing where it is to be cut. Place the cutter wheel on the mark and turn the tubing cutter adjustment wheel clockwise to force the cutter against the tubing. Revolve the cutter around the tubing, slightly turning the adjustment knob on each revolution until the tubing is cut through.
- 245 - 1. One which is composed of equal weights of tin and lead, commonly called 50/50.
- 245 - 2. Equal parts of tin and lead make up the contents of soft solder 50/50.
- 245 - 3. Another term for hard solder is brazing solder.
- 245 - 4. Hard and soft solder, also called brazing solder and tin solder.
- 246 - 1. Melting solder can be accomplished by using the air-acetylene torch or the common propane torch.



- 247 - 1 The swaging process can be used by a heating man when sweat fittings are not readily available.
- 247 - 2 The swaging process involves expanding one section of copper tubing so that another section of tubing will fit snugly
- 247 - 3. Soldering permanently joins the sections of copper tubing
- 248 - 1 Solder flow uphill is governed by the law of capillary attraction
- 248 - 2. Applying damp rags to the soldered joint hastens the cooling process
- 248 - 3 A soldered connection that leaks probably was not cleaned properly
- 248 - 4 The amount of solder needed to solder a section of 2-inch tubing or pipe would be 2 inches, based on a solder diameter of $\frac{1}{8}$ inch
- 248 - 5 If the tubing is not heated evenly the flux will burn out causing the solder to flow unevenly, also the solder may flow away. Both results would cause the connections to leak
- 249 - 1 A flare fitting which is not airtight or watertight would indicate that the flare was made oversized or undersized
- 249 - 2 Installing copper tubing on a fuel pump would necessitate an adapter, because the fuel pump has standard female threads
- 249 - 3. A flared connection can be disassembled and assembled easily
- 249 - 4 The tubing being expanded oversized would not fit the compression nut properly
- 249 - 5 The tubing connection not flared enough would result in leakage
- 250 - 1 The procedures necessary in fabricating a copper tubing system are cutting, reaming, and flaring where necessary. Using correct type and size fittings, connect—making sure of a proper fit

CHAPTER 4

- 251 - 1 Heat is transferred by means of radiation, conduction, and convection
- 251 - 2 Conduction is dependent on direct contact with a substance
- 251 - 3 Convection is the transfer of heat by means of mediums such as water, air, and steam.
- 251 - 4 Conduction allows transfer of heat through solids
- 252 - 1 A Btu is a unit of measurement for a given quantity of heat. One Btu is the amount of heat needed to change the temperature of 1 pound of pure water 1 Fahrenheit at sea level
- 252 - 2. There are 180 between the freezing point and the boiling point of the Fahrenheit thermometer.
- 252 - 3 Heat and temperature are different in the sense that a given amount of water at a lower temperature will melt more ice than a smaller amount of water at a higher temperature.
- 253 - 1 $C = (180 - 32)$ multiplied by $\frac{5}{9}$ or $5/9$.
 $C = 140$ multiplied by $\frac{5}{9}$ or $5/9$
 $C = 82$

- 253 - 2 $F = (80 \times 1.8) + 32$
 $F = 144 + 32 F$
 $F = 176$
- 254 - 1 All substances contain heat when their temperature is above absolute zero (460 F).
- 254 - 2. To find the total heat, add the sensible heat and latent heat together
- 254 - 3. Sensible heat is the heat which can be measured by a thermometer.
- 254 - 4 Latent heat is that heat which changes the state of a substance.
- 254 - 5. 460 F below zero is considered absolute zero because molecules at this temperature cease to have motion
- 255 - 1 The volume of water increases (expands) when the temperature is increased and the pressure remains constant
- 255 - 2 The volume would remain constant
- 256 - 1 The elements of combustion are fuel, air, and heat
- 256 - 2 Heat has to be added to any fuel so that the fuel can reach its ignition, or kindling point
- 256 - 3 The absence of either fuel, air, or heat will prevent combustion from taking place.
- 256 - 4 The kindling point is the minimum temperature a fuel must reach in order to ignite or flame
- 257 - 1. The total amount of air needed for combustion depends on the type of fuel, depth of fuel bed, size of fire pot, amounts of noncombustible materials, and resistances offered by combustion chamber passages.
- 257 - 2. Secondary air is the excess air needed for the combustible gases to burn properly
- 257 - 3. Theoretical air is primary air, or air needed for ignition of fuel. Excess air is the air needed to complete the burning process
- 258 - 1. The elements of combustion are oxygen (O_2), carbon dioxide (CO_2), and carbon monoxide (CO).
- 258 - 2. Perfect combustion could be obtained only if it were possible to burn pure carbon and cause the resulting flue gas to contain 20 percent carbon dioxide.
- 258 - 3. The percentage of carbon dioxide obtained in the flue gas is a direct indicator of the degree of perfection being attained in the combustion process.
- 259 - 1. The greatest source of heat loss is through the chimney
- 259 - 2. The methods of heat loss are losses through the chimney: losses through the grates; and losses through radiation, convection, and conduction.
- 259 - 3. Heat losses that occur in a room or using area are classified as transmission and infiltration losses.
- 260 - 1. Positive draft is draft pressure at or above atmospheric pressure.
- 260 - 2. The advantages of damper controls are lowest cost of all types of controls, ease with which it can be operated or adapted to automatic control, the least expensive type of fan drive and it is a continuous rather than a step type control and is therefore



- effective throughout the entire range of fan control
- 260 - 3 Cold air leakage lowers the stack temperature and available draft and it also increases the quantity of gas the stack must handle
- 261 - 1 Observing smoke being released from the stack or chimney is a good method of checking combustion efficiency
- 261 - 2 There are three methods of controlling fuel-air ratio. One is keep fuel constant any vary the air, another is keep the air constant and vary the fuel, and the third is to vary both fuel and air
- 262 - 1 The desirable percentages of CO₂ in the flue gas for coal, oil, and gas is 12 percent, 10 percent, and 8 percent, respectively
- 262 - 2 The entire 20 percent of oxygen (total amount in the air we breathe) combines with carbon atoms in perfect combustion
- 262 - 3 The two common methods of performing combustion analysis are with an absorption and a comparison analyzer
- 263 - 1 The two common types of absorption analyzers are the Fyrite and Orsat.
- 263 - 2 The installed comparison flue gas analyzer is called the condu-therm.
- 263 - 3 The gases that the Fyrite is capable of measuring are carbon dioxide (CO₂) and Oxygen (O₂)
- 264 - 1 The reason for pumping the bulb 18 times is to insure that enough of the gas sample reaches the analyzer.
- 264 - 2 Position one on the three-way cock allows the gas sample to reach the burette.
- 264 - 3 Depressing the plunger purges the unit.
- 264 - 4 You must make sure that the liquid in each pipette is at the mark on the neck to obtain a correct reading.
- 264 - 5 Raising and lowering the leveling bottle works out any gas bubbles.
- 264 - 6 Repeating the measurement of CO₂ insures the correct percentage.
- 264 - 7 A reference gas is used so that a comparison can be made in obtaining the correct CO₂ percentage.
- 264 - 8 When the percentage of the gas to be measured increases, the reference gas percentage increases.
- 265 - 1 To find the net stack temperature, subtract the room temperature from the stack temperature.
- 265 - 2 a. For natural gas, with a net stack temperature of 520° F. and a 9.5 percentage of CO₂, your heat loss would be 22.4 percent and your total efficiency would be 77.6 percent.
- b. For sub-bituminous coal, a net stack temperature of 450° F. and CO₂ content at 5 percent, the heat loss would be 37.2 percent and your efficiency would be poor at 62.8 percent.
- 266 - 1 The chemicals that absorb carbon dioxide, oxygen, and carbon monoxide are cardisorber, pyrogallic acid, and cuprous chloride, respectively.
- 266 - 2 Two.

- 267 - 1 You should always consult the manufacturer's instructions, because they normally contain step-by-step outlines for repair
- 267 - 2 Prolonged skin contact with chemicals could result in serious burns.
- 267 - 3 If a victim was not given immediate first-aid when overcome by an overexposure to chemical fumes, severe illness or death could result
- 268 - 1 Smoke is characteristically a dark color because of the finely divided soot particles released during combustion
- 268 - 2 A heating plant produces smoke, which combines with fog to produce smog
- 269 - 1 Ash is unburned carbon (not soot), consisting of particles large enough to see and feel.
- 269 - 2 Main contaminants of air contributed by the heating field are smoke, soot, ash, and dust
- 269 - 3 "Dust" to a heating man is cinder particles and fly ash particles
- 270 - 1 An amount of 0.85 pounds per 1000 pounds of flue gas is permissible by ASME standards
- 270 - 2 No, some ordinances are stated in grams per cubic foot
- 271 - 1 The major items of control are the collectors, mechanical and electrical
- 271 - 2 An electrical precipitator.

CHAPTER 5

- 272 - 1 Anthracite coal is referred to as hard coal
- 272 - 2 Lignite usually has the highest moisture content.
- 272 - 3 Oil would most likely be used because it is easily transported by air when necessary.
- 272 - 4 Number 6 fuel oil has the highest resistance to flow, therefore, it has the highest viscosity
- 272 - 5 Grades 5 and 6 are usually used in installations equipped with preheating facilities.
- 272 - 6 It is not always feasible to store natural gas in above-ground containers
- 272 - 7 The byproduct gases must be used immediately
- 272 - 8 You would probably be using LPG (propane), because its boiling point, or the temperature at which it will change from a liquid to a gaseous state, is -42° F
- 273 - 1 Spontaneous combustion will result when some coals are stacked too high in the storage piles.
- 273 - 2 When a fire is discovered in a coal pile, you should spread or shift the coal so that the fire can be isolated and extinguished.
- 273 - 3 An allowance of 20 feet is required between stock piles.
- 274 - 1 The clamshell crane is used for all functions of coal storage operation except unloading self-clearing hopper cars.
- 274 - 2 Three portable conveyor units are authorized at installations with a 1500-ton consumption rate.



- 274 - 3. Car unloader, truck unloader and conveyer stacker
- 275 - 1. It is necessary to preheat some grades of oil to reduce their resistance to flow so that they can be burned.
- 275 - 2. The advantages of electric preheaters are that they can be used when fuel heating installations are far from steam lines and when the plant does not have an auxiliary fuel to start with.
- 276 - 1. Strainers are installed in oil supply lines to remove water, dirt, and other foreign matter which might clog the pumps and nozzles.
- 276 - 2. The capacity of the dikes should be equal to that of the tank or tanks which they surround. With five tanks of 1500 gallons each, the dike's capacity should be 7500 gallons.
- 276 - 3.
 - a. The pumps are used to pump fuel from the storage tank to the burner, or to pump fuel from the burner to the tank.
 - b. The master valves control the fuel oil to the burner.
 - c. Strainers keep the fuel oil to the burners clean.
- 277 - 1. The amount of oil flowing to a gravity one-pipe oil supply system is determined by the amount of oil being consumed by the burner.
- 277 - 2. The double-pipe, gravity-feed, forced-return oil supply system is subject to a flooding combustion chamber due to failure of the return pump.
- 277 - 3. Single-pipe, gravity-feed system; single-pipe, forced-feed system, double-pipe, gravity-feed, forced-return system; and the double-pipe, forced-feed, gravity-return system.
- 278 - 1. The installation Liquid Fuels Facilities Engineer and the Industrial Hygiene Engineer will supervise the operations.
- 278 - 2. Cleanliness prevents or guards against toxic poisoning from entering the body.
- 279 - 1. Air Force Regulation 91-7, *Heating*, gives the efficiency of the heating units.
- 279 - 2. A stoker-fired furnace should be 15 percent better than a hand-fired furnace; this is the difference between 65 percent and 50 percent efficiency.
- 279 - 3. Fuel requirements are computed each year for all heating units, regardless of type.
- 279 - 4. The difference between the desired inside design temperature and the outside design temperature.
- 279 - 5. The standard barrel is the standard unit of measure for oil.
- 279 - 6. There are 42 gallons in a standard barrel.
- 279 - 7.
 - a. $\frac{80,000 \times 24 \times 7500}{80 \times 0.65 \times 20,000,000} = 13.8$ tons of coal
 - b. $\frac{156,000 \times 24 \times 7500}{.80 \times 0.65 \times 1000} = 4,320$ therms of gas
- 279 - 8. The standard measure of gas is the therm.
- 279 - 9. For each 1000 feet of elevation, five percent should be deducted from the Btu capacity of the unit. So for 10,000 feet of elevation, a

- unit with a 200,000-Btu capacity is reduced to 100,000 Btu
- 280 - 1. A visual inspection must be accomplished before a coal shipment is unloaded.
- 280 - 2. A coal shipment is visually inspected to insure that it is reasonably free from excessive moisture and foreign material, that there is no loss, and that the shipment has been properly prepared.
- 281 - 1. Visual inspections of coal shipments should be assigned to Civil Engineer Personnel whose tour of duty is not likely to change frequently.
- 281 - 2. Record is made on AF Form 97, if the contents of the coal car appears to have been disturbed.
- 281 - 3. The entire top of a carload or truckload of coal should be walked and the size and composition observed.
- 282 - 1. A gross sample shall not represent more than 1000 tons.
- 282 - 2. A certified coal sampler is responsible for the accuracy of the coal sample.
- 282 - 3. Gross coal samples are stored in clean, airtight containers to avoid evaporation of moisture and possible contamination.
- 283 - 1. You will ship them approximately 3 pounds of coal for each sample.
- 283 - 2. The coal crusher should be equipped with a riffle splitter to separate the coal sample into two equal parts.
- 284 - 1. The first indication is the appearance of steam and the odor of coal gas being given off from the pile.
- 284 - 2. When this temperature exists, you should remove the hotspot immediately.
- 284 - 3. When the weather suddenly becomes warm, the oil expands and overflows the tank. This creates a fire hazard.
- 284 - 4. Heat in the form of a spark or flame is enough to ignite gas vapors.
- 284 - 5. You should install proper air vents to prevent the overflow of oil.
- 285 - 1. Gas leaks are usually found by using a soap solution.
- 285 - 2. A soap bubble will form at the place a gas leak exists.
- 286 - 1. It is possible for an open sieve to become tangled in moving machinery, thus resulting in the possibility of an injury.
- 286 - 2. Protective clothing and equipment aids in safeguarding the health and safety of personnel involved in fuel handling.
- 287 - 1. In unloading fuel oil, you should take every precaution to insure that no static electricity exists in the vicinity of the operation.
- 287 - 2. A proper area, experienced personnel, equipment in good repair, proper records, and the knowledge of coal characteristics.
- 288 - 1. Static electricity is created by contact and separation of two unlike objects, or by almost any sort of motion of persons or material.



- 288 - 2. Static electricity can be controlled by procedures known as grounding and bonding.
- 288 - 3. Bonding will equalize the charge between two electrically connected objects, and the ground will carry the charge off without danger.
- 289 - 1. Malfunctions can happen in grounding and bonding systems because of weather factors, contamination, and mechanical wear.
- 290 - 1. A pump used in the movement of water and oil is an example of power transmission machinery.
- 290 - 2. Power transmission machinery and point-of-operation are two areas that require proper machine guarding.
- 290 - 3. You should insure that the power switch is "locked" in the off position and that adequate identification signs are posted.

U.S. GOVERNMENT PRINTING OFFICE: 1974 O-349-056 113
 AUGAFS, ALA (750290) 3200

211



STOP -

1. MATCH ANSWER SHEET TO THIS EXERCISE NUMBER.

2. USE NUMBER 1 OR NUMBER 2 PENCIL.

11-1 209

54730 02 24

EXTENSION COURSE INSTITUTE
VOLUME REVIEW EXERCISE

FUNDAMENTALS

Carefully read the following:

DO'S:

1. Check the "course," "volume," and "form" numbers from the answer sheet address tab against the "VRE answer sheet identification number" in the righthand column of the shipping list. If numbers do not match, take action to return the answer sheet and the shipping list to ECI immediately with a note of explanation.
2. Note that numerical sequence on answer sheet alternates across from column to column.
3. Use a medium sharp #1 or #2 black lead pencil for marking answer sheet.
4. Circle the correct answer in this test booklet. After you are sure of your answers, transfer them to the answer sheet. If you *have* to change an answer on the answer sheet, be sure that the erasure is complete. Use a clean eraser. But try to avoid any erasure on the answer sheet if at all possible.
5. Take action to return entire answer sheet to ECI.
6. Keep Volume Review Exercise booklet for review and reference.
7. If *mandatorily* enrolled student, process questions or comments through your unit trainer or OJT supervisor.
If *voluntarily* enrolled student, send questions or comments to ECI on ECI Form 17.

DON'TS:

1. Don't use answer sheets other than one furnished specifically for each review exercise.
2. Don't mark on the answer sheet except to fill in marking blocks. Double marks or excessive markings which overflow marking blocks will register as errors.
3. Don't fold, spindle, staple, tape, or mutilate the answer sheet.
4. Don't use ink or any marking other than a #1 or #2 black lead pencil.

NOTE: NUMBERED LEARNING OBJECTIVE REFERENCES ARE USED ON THE VOLUME REVIEW EXERCISE. In parenthesis after each item number on the VRE is the *Learning Objective Number* where the answer to that item can be located. When answering the items on the VRE, refer to the *Learning Objectives* indicated by these *Numbers*. The VRE results will be sent to you on a postcard which will list the *actual VRE items you missed*. Go to the VRE booklet and locate the *Learning Objective Numbers* for the items missed. Go to the text and carefully review the areas covered by these references. Review the entire VRE again before you take the closed-book Course Examination.

Multiple Choice

1. (200) Anything that occupies space and has weight is called
 - a. matter.
 - b. molecules.
 - c. atoms.
 - d. particles.
2. (200) The smallest part of a substance that still retains the characteristics of that substance is called
 - a. an atom.
 - b. a proton.
 - c. a neutron.
 - d. a molecule.
3. (200) According to the electron theory, atoms are composed of
 - a. molecules and nucleus.
 - b. protons and molecules.
 - c. protons, neutrons, and electrons.
 - d. electrons, protons, and molecules.
4. (200) The electrons in an atom carry a
 - a. negative charge.
 - b. positive charge.
 - c. negative or neutral charge.
 - d. positive or neutral charge.
5. (201) Which of the following factors must be present before you can have an operating electric circuit?
 - a. Voltage and current.
 - b. Voltage and a conductor.
 - c. Voltage, current, and resistance.
 - d. Voltage, current, and insulation.
6. (201) One (1) volt is the electrical pressure required to force
 - a. 1 ampere of current through 1 foot of conductor.
 - b. 1 ampere of current through a resistance of 1 ohm.
 - c. 1 ohm through 1 foot of conductor.
 - d. 1 ampere of current through any amount of resistance.
7. (201) Which of the following does current always produce when flowing through a conductor?
 - a. Heat.
 - b. Shock.
 - c. Chemical action.
 - d. Heat and shock.
8. (203) When connecting equipment to branch circuits, you must be concerned with the
 - a. rpm of the equipment.
 - b. horsepower of the equipment.
 - c. current requirement of the equipment.
 - d. wire size of the branch circuit.
9. (204) Controls for heating systems are connected in the circuit in
 - a. parallel.
 - b. series.
 - c. branch and parallel.
 - d. series and parallel.
10. (205) Schematic drawings are simplified drawings of
 - a. blueprints.
 - b. specifications.
 - c. wiring diagrams.
 - d. wiring symbols.



- 211
11. (207) When troubleshooting an electrical circuit, which meter cannot be connected to a live circuit?
 - a. Ohmmeter.
 - b. Ammeter.
 - c. Voltmeter.
 - d. Galvanometer.
 12. (208) A circuit having 1,680 watts at 120 volts will have a current flow of
 - a. 16 amps.
 - b. .07 amps.
 - c. 14 amps.
 - d. 1.4 amps.
 13. (209) Which of the following is the most probable cause for loose connections in a distribution panel?
 - a. Vibration.
 - b. Poor workmanship.
 - c. Wire too large for connector.
 - d. Wire too small for connector.
 14. (209) When checking a fuse box, you find one end of a fuse discolored. The probable cause of this is
 - a. an overloaded circuit.
 - b. a wrong fuse size.
 - c. a poor connection.
 - d. a wrong type fuse.
 15. (213) The pressure control cut-in pressure operating a boiler is set at 80 pounds and a differential of 16 pounds. The cutout pressure should be
 - a. 14 pounds.
 - b. 16 pounds.
 - c. 90 pounds.
 - d. 96 pounds.
 16. (214) In heating equipment, most controls can be classified as
 - a. cutouts.
 - b. switches.
 - c. automatic.
 - d. electrical solenoids.
 17. (215) When checking a thermostat with a test thermometer, it should hang within
 - a. 2 inches of the thermostat.
 - b. 3 inches of the thermostat.
 - c. 4 inches of the thermostat.
 - d. 5 inches of the thermostat.
 18. (215) It is necessary to calibrate a thermostat when it varies over
 - a. 4° F. from the test thermometer.
 - b. 3° F. from the test thermometer.
 - c. 2° F. from the test thermometer.
 - d. 1° F. from the test thermometer.
 19. (218) The fundamental law of magnetism states that
 - a. like poles repel and unlike poles attract.
 - b. like poles attract and unlike poles repel.
 - c. the north pole of a magnet points north.
 - d. like poles attract.
 20. (220) As used in an electrical circuit, a relay is
 - a. a manually operated switch.
 - b. a junction between circuits.
 - c. an electrically controlled switching device.
 - d. a protective device for the circuit.

- 21. (220) A water control valve may be opened and closed electrically by a
 - a. converter.
 - b. relay.
 - c. magnetic switch.
 - d. solenoid.
- 22. (222) The transformer coil in which the electricity is induced is always the
 - a. primary.
 - b. secondary.
 - c. low voltage side.
 - d. high voltage side.
- 23. (222) During the shorting test of the transformer in the ignition circuit of an oil burner, the minimum size gap which the spark should jump is
 - a. 1/4 inch.
 - b. 1/2 inch.
 - c. 3/4 inch.
 - d. 1 inch.
- 24. (224) New drive belts have been installed on a motor driven unit. The belt tension should be rechecked within
 - a. 2 hours.
 - b. 48 hours.
 - c. 15 days.
 - d. 30 days.
- 25. (226) The inspection of a 12-foot electrical cable reveals a number of cracks in the insulation in a 3-foot section near the center. For the line to be serviceable, this cable should
 - a. be removed and replaced.
 - b. have the cracked area taped.
 - c. have the cracked section replaced with new cable.
 - d. have the cracked area removed and the ends rejoined.
- 26. (226) When working with rotating equipment, you should be especially careful to avoid
 - a. wearing loose clothing.
 - b. pointed tools.
 - c. having keys in pockets.
 - d. grounded surfaces.
- 27. (226) To be absolutely certain that an electrical circuit is dead, you must open switches and
 - a. lock them open.
 - b. tag them as open.
 - c. check circuit with ammeter.
 - d. check circuit with voltmeter.
- 28. (230) If you want to observe peak voltages and breakdown voltages in an electronic unit, the unit should be checked with
 - a. a voltmeter.
 - b. an electronic indicator.
 - c. an oscilloscope.
 - d. an amplitude meter.
- 29. (232) After the lockout switch on the FP-2 control system trips, it is reactivated
 - a. automatically after all functions shut off.
 - b. automatically after a cooling period.
 - c. by manual resetting in the safety position.
 - d. by manual resetting after a cooling period.
- 30. (233) A flame current test must be made on a RA890F electronic control system at least
 - a. weekly.
 - b. monthly.
 - c. semiannually.
 - d. annually.

- 31. (233) Spare FP-2 control units should be installed and operated to insure proper working condition at least every
 - a. month.
 - b. 2 months.
 - c. 6 months.
 - d. year.
- 32. (234) The supply air pressure for pneumatic temperature controls is usually
 - a. 5 to 8 psi.
 - b. 5 to 6 psf.
 - c. 15 to 20 psi.
 - d. 15 to 20 psf.
- 33. (234) The term "set point" for a pneumatic temperature controller is the
 - a. value at which it will open.
 - b. value at which it will close.
 - c. value it attempts to maintain.
 - d. range over which it is set.
- 34. (236) Where should you obtain information for adjusting a pneumatic control room thermostat?
 - a. T's.
 - b. AF's.
 - c. AFPS.
 - d. Manufacturer's instructions.
- 35. (237) When adjusting a heating-cooling thermostat, the ambient temperature is measured at the
 - a. regulator element.
 - b. sensing element.
 - c. air outlet duct.
 - d. air return duct.
- 36. (238) Which of the following describes a short nipple?
 - a. Threaded full length.
 - b. Two to twelve inches long.
 - c. Threaded on both ends to the center.
 - d. Threaded on both ends with a shoulder between.
- 37. (240) When measuring a pipe, the center to center method is used when
 - a. an accurate measurement is desired.
 - b. a fitting is screwed on both ends.
 - c. a fitting is screwed on one end.
 - d. the pipe is longer than the tape you are using.
- 38. (240) Pipe sizes of 1/4 to 3/8 inch have
 - a. 10 threads per inch and 1 1/2-inch thread length.
 - b. 12 threads per inch and 1-inch thread length.
 - c. 14 threads per inch and 13/16-inch thread length.
 - d. 18 threads per inch and 5/8-inch thread length.
- 39. (241) When cutting pipe threads, what should be done to prevent overheating of the die and threads?
 - a. Cut threads as slow as possible.
 - b. Move die handle up and down.
 - c. Use cutting oil.
 - d. Use water spray.
- 40. (242) Hard temper copper tubing may be annealed by
 - a. filling with sand and heating.
 - b. bending.
 - c. heating to a dull red and allowed to cool.
 - d. heating and cooling quickly in oil.





- 41. (244) What type of hacksaw blade should be used to cut copper tubing?
 - a. A blade with 14 teeth per inch.
 - b. A blade with 18 teeth per inch.
 - c. A blade with 24 teeth per inch.
 - d. A blade with 32 teeth per inch.

- 42. (246) The air-acetylene torch produces a flame temperature up to
 - a. 1500° F.
 - b. 2000° F.
 - c. 3500° F.
 - d. 4000° F.

- 43. (247) The purpose of swaging a piece of copper tubing is to
 - a. soften the tubing.
 - b. make it rigid for hanging from the ceiling.
 - c. make one end inside diameter larger than the outside diameter of the other.
 - d. prepare it for soldering.

- 44. (249) The main advantage(s) of tubing flare joints is, (are)
 - a. they disassemble easily to make repairs.
 - b. they make a water and airtight seal.
 - c. they are fast and easy to make.
 - d. all of the above.

- 45. (249) When making a flare, the tubing end is placed in the flare block approximately
 - a. 1/16 inch above the flare block.
 - b. 1/4 inch above the flare block.
 - c. the wall thickness of the tubing above the block.
 - d. twice the wall thickness of the tubing above the block.

- 46. (251) Radiated heat
 - a. cannot be transferred.
 - b. is transferred by heat waves.
 - c. is transferred by convection.
 - d. cannot be used to heat air.

- 47. (252) For a thermometer to measure the degree of sensible heat of different bodies, it must compare between
 - a. the bodies.
 - b. the body and Fahrenheit.
 - c. Fahrenheit and Celsius.
 - d. a specific reference and the body.

- 48. (253) Celsius temperature of 70° equals a Fahrenheit temperature of
 - a. 360°.
 - b. 158°.
 - c. 21.1°.
 - d. 15.8°.

- 49. (255) When the temperature is held constant and the pressure is increased on a gas, the
 - a. volume will decrease.
 - b. volume will increase.
 - c. volume will remain the same.
 - d. pressure, temperature, and volume must increase.

50. (256) The flash point for fuel oils is the
- maximum temperature of the fuel.
 - minimum temperature for ignition.
 - carbon and hydrogen content for ignition.
 - heat, fuel, and amount of air needed for ignition.
51. (257) Maximum combustion efficiency can be controlled best by
- varying the amount of air when the burner uses a constant amount of fuel.
 - varying the amount of fuel when the burner uses a constant amount of air.
 - varying both the amount of fuel and air.
 - all of the above.
52. (258) Incomplete combustion in heating units is caused by
- the lack of hot coals.
 - an insufficient air supply.
 - too much oxygen.
 - part of the heating unit having burned out.
53. (259) In a heat furnace, the flue gas being produced is CO. For more complete combustion, you should add
- air.
 - fuel.
 - heat.
 - CO₂.
54. (259) In combustion type heat units, the greatest heat loss to the atmosphere is through
- radiation.
 - the chimney.
 - convection.
 - conduction.
55. (259) Heat lost through the walls, floor, and ceiling of the using area is called
- transmission loss.
 - infiltration loss.
 - conduction.
 - radiation.
56. (260) Flue gas temperatures should be maintained above
- 260° F.
 - 270° F.
 - 280° F.
 - 290° F.
57. (261) Smoke indicates good combustion efficiency when it is
- white.
 - not visible.
 - a light brown.
 - black then clears to white.
58. (262) Flue gases from coal burning boilers equipped with automatic firing equipment and combustion controls should contain not less than
- 10 percent CO₂.
 - 12 percent CO₂.
 - 14 percent CO₂.
 - 16 percent CO₂.
59. (262) The types of analyzers used to determine combustion efficiency are the
- absorption and Fyrite.
 - absorption and Orsat.
 - Orsat, Fyrite, and CO₂ analyzers.
 - comparison and absorption.

6 7

- 214
60. (265) In order to compute combustion efficiency, you must know the CO₂ percentage, flue gas temperature, the type of fuel used, and the
- a. room temperature.
 - b. size of the unit.
 - c. input Btu content.
 - d. amount of air to fuel used.
61. (267) A malfunctioning flue gas analyzer should be
- a. sent to PMEL.
 - b. returned to the distributor.
 - c. repaired according to 35E7 series TOs.
 - d. repaired according to manufacturer's recommendations.
62. (267) Why should strict safety precautions be used when repairing absorption type analyzers?
- a. Dangerous chemicals are in the analyzers.
 - b. Chemicals will ignite when exposed to the atmosphere.
 - c. The glass tubes may break while cleaning.
 - d. Small parts are present which may become lost during the cleaning process.
63. (268) Unburned carbon released during combustion causes soot and smoke ranging in size from
- a. .0001 to .001 micron.
 - b. .001 to .01 micron.
 - c. .01 to 1.00 micron.
 - d. 1.00 to 2.01 micron.
64. (269) Most common fuels add pollution to the atmosphere in the form of
- a. ash.
 - b. smoke.
 - c. dust.
 - d. all of the above.
65. (271) Electrical precipitators for air pollution control operate with efficiencies of
- a. 95 percent.
 - b. 96 percent.
 - c. 98 percent.
 - d. 99.5 percent.
66. (272) The biggest problem of clinkering and slagging comes from
- a. moisture content.
 - b. ash and sulfur.
 - c. carbon and sulfur.
 - d. carbon, moisture, and nitrogen.
67. (272) The exact chemical composition of coal is determined by the
- a. ash analysis.
 - b. carbon analysis.
 - c. proximate analysis.
 - d. ultimate analysis.
68. (272) Fuel oils are numbered in grades
- a. 2, 3, 4, 5, and 6.
 - b. 1, 2, 4, 5, and 6.
 - c. 1, 3, 4, 5, and 6.
 - d. 1, 2, 3, 5, and 6.
69. (272) Which of the fuel oils has the highest Btu per gallon?
- a. Number 1 and 6.
 - b. Number 2 and 5.
 - c. Number 1 and 2.
 - d. Number 5 and 6.
70. (272) Fuel oil vapors are
- a. heavier than air.
 - b. lighter than air.
 - c. the same weight as air.
 - d. lighter than water vapor.

- 71. (272) Before natural gas is distributed, it has
 - a. a distinctive odor added.
 - b. an amber color added.
 - c. to be compressed to a liquid gas.
 - d. ethane added.
- 72. (273) Bituminous lump, egg, and nut coal should not be piled higher than
 - a. 16 feet.
 - b. 18 feet.
 - c. 20 feet..
 - d. 24 feet.
- 73. (273) Storage piles of coal should be inspected for evidence of excessive heating or spontaneous combustion at least
 - a. once a week.
 - b. once every 2 weeks.
 - c. once a month.
 - d. three times a month.
- 74. (273) Hot or burning coal is best removed from a stock pile with a
 - a. hand shovel.
 - b. bulldozer.
 - c. front-end loader.
 - d. clamshell crane.
- 75. (274) A car unloader, truck unloader, and conveyor stacker are authorized for each
 - a. 500 tons of coal handled annually.
 - b. 1000 tons of coal handled annually.
 - c. 3000 tons of coal handled annually.
 - d. 5000 tons of coal handled annually.
- 76. (275) To adequately pump number 6 fuel oil, the viscosity should be about
 - a. 700 SSF.
 - b. 200 SBF.
 - c. 600 SSU.
 - d. 600 SBU.
- 77. (276) The purpose of grounding an above-ground fuel oil storage tank is to
 - a. protect against corrosion.
 - b. discharge any A.C. voltage.
 - c. protect the cathodic system.
 - d. discharge static electricity to ground.
- 78. (276) Cathodic protection is often used on
 - a. electric heaters.
 - b. below the water line heaters.
 - c. below-ground storage tanks.
 - d. above-ground storage tanks.
- 79. (276) The advantage of using a duplex strainer in the fuel oil system is that
 - a. the fuel will be cleaner.
 - b. it never needs cleaning.
 - c. it requires cleaning only once per year.
 - d. it can be cleaned without shutting down the unit.
- 80. (277) What happens to the unused fuel oil in a single pipe forced feed supply system?
 - a. It is returned to the storage tank.
 - b. It is returned to another storage tank.
 - c. It is recirculated through the pump.
 - d. The pump stops when the burner is full.

- 81. (278) Oil strainers should be cleaned at regular intervals with
 - a. water and soap solution.
 - b. steam or hot water.
 - c. air pressure and solvent.
 - d. gasoline and hot water.
- 82. (278) Fuel oil supply lines are checked for leaks by
 - a. starting each pump in succession.
 - b. using a soap and water solution.
 - c. a visual inspection.
 - d. using an inert gas.
- 83. (279) A 100,000-Btu gas furnace operating at 5,000 feet above sea level will produce
 - a. 55,000 Btu's.
 - b. 75,000 Btu's.
 - c. 85,000 Btu's.
 - d. 95,000 Btu's.
- 84. (279) The efficiency of the heating unit and the Btu content of the fuel may be found in
 - a. the supplier's handbook.
 - b. AFR 91-7.
 - c. AFM 91-7.
 - d. AFR 91-8.
- 85. (280) Certified weight bills are to be furnished for all
 - a. coal deliveries.
 - b. fuel deliveries.
 - c. carload deliveries.
 - d. truckload deliveries.
- 86. (280) When receiving carloads of coal, a visual inspection is made to determine
 - a. if the coal is double screened.
 - b. if the coal is double or single screened.
 - c. the size only.
 - d. the impurities, size, and composition.
- 87. (281) A record of coal loss during shipment is recorded on
 - a. AF Form 79.
 - b. AF Form 97.
 - c. DOD Form 79.
 - d. DOD Form 97.
- 88. (282) Methods of collecting and preparing coal samples are described in
 - a. AFR 85-15.
 - b. AFM 85-15.
 - c. AFR 85-18.
 - d. AFM 85-18.
- 89. (282) Who may collect and prepare coal samples?
 - a. Personnel from the mines.
 - b. Qualified personnel.
 - c. Personnel certified as qualified.
 - d. The base civil engineer.
- 90. (282) Carload sampling should be taken from the
 - a. first or last spilling from the hopper car.
 - b. top left and right side of the hopper car.
 - c. top right and left side of the hopper car.
 - d. stream of coal being discharged.



91. (282) To obtain "top sampling" for inspection from a car of coal, you should dig into the coal to a minimum depth of
- a. 6 inches.
 - b. 12 inches.
 - c. 18 inches.
 - d. 24 inches.
92. (284) Storage piles of coal should be inspected for evidence of excessive heating or spontaneous combustion at least
- a. once a week.
 - b. twice a week.
 - c. once every two weeks.
 - d. once a month.
93. (284) A 3/4-inch pipe placed every 25 feet in a coal pile serves
- a. in checking the temperature of the pile.
 - b. as a point for daily fuel consumption.
 - c. as an aid when stock piling the coal.
 - d. to remove coal gas odors.
94. (284) Dirty fuel oil tank vents may cause
- a. the tank to explode.
 - b. the fuel oil to overflow.
 - c. damage to fuel oil supply system.
 - d. a decrease in fuel consumption.
95. (285) A gas leak test should be performed on all equipment
- a. while the system is secured.
 - b. once per year.
 - c. with soapy water while the system is under pressure.
 - d. once per week while the system is operating.
96. (288) The purpose of grounding fuel tanks is to
- a. eliminate lightning from striking the tank.
 - b. eliminate all electrical hazards.
 - c. drain off all electrical potentials.
 - d. control static electricity.
97. (288) Bonding is one method of
- a. eliminating static electric potentials.
 - b. securing two objects together.
 - c. testing for static electrical potentials.
 - d. eliminating all electrical hazards.
98. (290) When are power controls locked in the "off" position?
- a. Never, because it's against Air Force regulations.
 - b. When repairs are made on the equipment.
 - c. When the operators leave the area.
 - d. Only at the end of the shift.

220

54730 03 7501

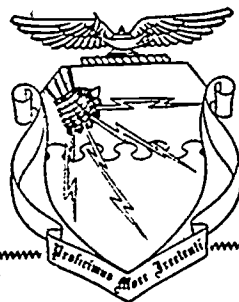
CDC 54730

APPRENTICE HEATING SYSTEMS SPECIALIST

(AFSCs 54730 and 54730A)

Volume 3

Heating Systems



11-1

Extension Course Institute

Air University

222

Preface

THE PURPOSE of Volume 3 of this course is to present a description of space heating and unit heaters, burners, warm-air systems, and domestic hot-water heating systems. The chapters of this volume and the exercises are part of the basic instructions for candidates who wish to advance to the 3 level, Apprentice Heating Systems Specialist, AFSC 54730/30A. Once you understand the material in this volume and the other volumes in this course, you should be well prepared for your advancement.

If you have any questions on the accuracy or currency of the subject matter of this text or recommendations for its improvement, send them to Tech Tng Cen/TTOC, Sheppard AFB TX 76311. NOTE: Do not use the suggestion program to submit corrections for typographical or other errors.

If you have questions on course enrollment or administration, or on any of ECI's instructional aids (Your Key to Career Development, Behavioral Objective Exercises, Volume Review Exercise, and Course Examination), consult your education officer, training officer, or NCO, as appropriate. If he can't answer your questions, send them to ECI, Gunter AFS AL 36118, preferably on ECI Form 17, Student Request for Assistance.

This volume is valued at 27 hours (9 points).

Material in this volume is technically accurate, adequate, and current as of November 1974.

Contents

	<i>Page</i>
<i>Preface</i>	iii
Chapter	
1 Space Heating - Unit Heaters	1
2 Burners	26
3 Warm-Air	54
4 Hot-Water Heating	78
 <i>Answers for Exercises</i>	 95



NOTE: In this volume, the subject matter is developed by a series of Learning Objectives. Each of these carries a 3-digit number and is in boldface type. Each sets a learning goal for you. The text that follows the objective gives you the information you need to reach that goal. The exercises following the information give you a check on your achievement. When you complete them, see if your answers match those in the back of this volume. If your response to an exercise is incorrect, review the objective and its text.

Space Heating-Unit Heaters

THE EARLIEST ways of heating homes were direct methods such as open fires with which primitive men warmed their cave dwellings. Some types of stoves and braziers (pans for holding burning coals) were adopted by the Romans and are still employed in various parts of the world. In the colder portions of Europe, the fireplace was eventually developed as a method for heating rooms. The first fireplaces were hearths with short flues recessed into the walls of buildings. Fireplaces with high chimneys that rose above the roof of the building and provided adequate draft to keep the fires on the hearth burning brightly, were introduced during the 12th century. Fireplaces of today consist of a hearth closed on three sides with brick, surrounded by a completely inclosed chimney or flue that carries away the smoke and combustion products of the fire. On the hearth is a metal grate raised on legs, or a pair of metal supports called *firedogs* or *andirons*. Grates that permit the circulation of air under the fuel for combustion purposes are used when coal or coke is used for fuel.

The useful heat given off by a fireplace consists of the heat radiated directly by the burning fuel and that which is absorbed and reradiated by the side and back walls. From 85 to 90 percent of the heat from burning fuel is lost in the combustion gases and smoke that go up the chimney. The inclusion of fireplaces in modern houses is for beauty and style rather than for their thermal efficiency.

In this section, we will discuss types of coal, oil, and gas space heaters that are more efficient heat producers than the fireplace. We will also study the installation, operation, and

maintenance of these heaters. You may be called upon at any time to install, operate, or maintain any one of these various types of space heaters. When you do have such an assignment, your supervisor will expect you to have a working knowledge of the type and of the fuel required to operate the heater. By gaining the knowledge contained in this section you will be able to better understand the construction, operation, and maintenance of the more complicated heating equipment you will use throughout your Air Force career.

1-1. Fundamentals of Space Heating

A space heater—or stove, as it is sometimes called—is an inclosure of metal or ceramic materials where fuel is burned to provide heat. It is an improvement over the fireplace because its radiating surface is relatively larger and in contact with the air of the room, and because it gives a certain amount of heat by air convection. An efficient modern space heater utilizes about 75 percent of the heat of the fuel burned in it. In rural areas of the United States and many other parts of the world, space heaters are still being used extensively for heating houses. The fuels burned in these types of heaters include wood, coal, coke, peat, oil, and gas.

Since the space heater is not a permanent installation, it can be located in a desirable place in the center of a room to provide the greatest amount of heat. However, the space heater is not very satisfactory in providing comfortable heat for a large space, because of its unique method of limited heat

distribution. Even so, the simplicity of construction, the small initial cost, and the low rate of fuel consumption—regardless of whether it is coal, gas, or oil—make the space heater desirable for heating small areas.

400. Name the three types of space heaters according to fuel and match construction features with a specific type of heater.

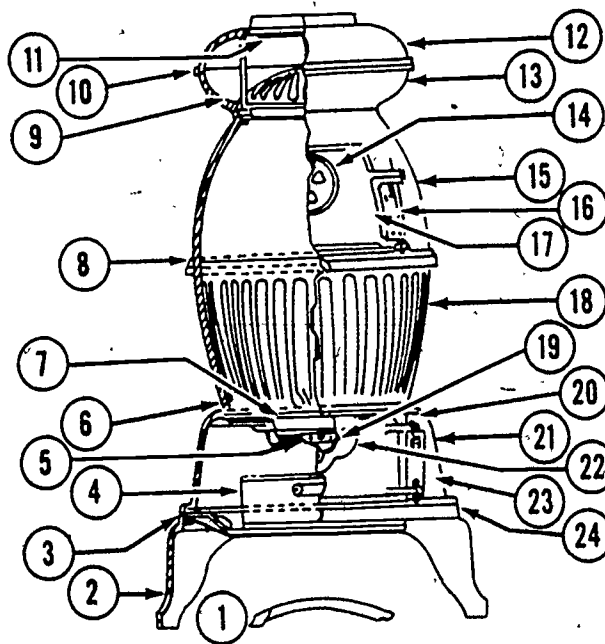
There are basically three types of space heaters: coal, oil, and gas.

Coal-Fired Space Heaters. Two types of coal-fired space heaters commonly used by the Air Force are the cannon stove and the magazine stove. The cannon stove is side-stoked, of potbelly design, and depends upon radiation for its heating effect. The

cannon stove shown in figure 1-1 is the space heater that is commonly known as the *potbelly* stove. It is constructed entirely of cast iron sections, which make it easy to transport and assemble. The major component parts of the cannon stove are the ashpit, (21), firepot(18), barrel(15), topneck(13), and topcollar(12). Figure 1-1 shows these as well as other major parts of the stove.

The ashpit section serves as a base for the heater. It catches the ashes as they fall through the grates into the ashpan. The ashpit section is supported by legs that keep the section from direct contact with the floor and thereby reduce the fire hazard.

The firepot, of circular construction, is that part of the heater where the coal is burned. The grates (5) are located directly above the ashpit in the lower part of the firepot. They



- | | |
|-------------------|---------------------------|
| 1. SHAKER LIFTER | 13. TOPNECK |
| 2. LEG | 14. FEED DOOR DRAFT PLATE |
| 3. CEMENT SEALER | 15. BARREL |
| 4. ASHPAN | 16. HINGED PLATE |
| 5. DRAW GRATE | 17. FEED DOOR |
| 6. CEMENT | 18. FIREPOT |
| 7. ROUND GRATE | 19. YOKE |
| 8. BAFFEL | 20. ASH DOOR |
| 9. CEMENT SEALER | 21. ASHPIT |
| 10. CEMENT SEALER | 22. ASH DOOR DRAFT PLATE |
| 11. COVER | 23. HINGED PLATE |
| 12. TOPCOLLAR | 24. BOTTOM |

Figure 1-1. The cannon stove.

are of finger-type construction and circular in shape. The movement of the grates is controlled by a shaker-lifter (1) that is inserted through an opening at the front of the ashpit. Shaking the grates removes the ashes and allows air to reach the fire.

The barrel of the stove, to which the feed door (17) is attached, is directly above the firepot section. The topneck and topcollar, to which the heater flue is attached, are supported by the barrel. The barrel, the topneck, and the topcollar are the principal means of heat radiation. The stove is fired by hand through the front feed door. Always check the fuel for dirt, metal, and glass before firing, and clean out the ashes that accumulate in the ashpit so as to prevent the grates from burning out. When removing these ashes, put them in fireproof metal or cement containers.

Different from the cannon type stove, the magazine stove is top-stoked, has steel jackets around the firebox, and depends primarily upon the circulation of air around the jacket and firebox for heating action. The magazine-type coal-fired space heater is (which is not shown) an improvement over the cannon stove. The one commonly used in

226
the Air Force is the US Army No. 1 space heater. It is called a magazine stove because the greater portion of the body (above the grates) is a reservoir, or magazine, for holding a large quantity of coal.

The drum, or main part of the body, is made of sheet steel, lined with firebrick and special flue brick to prevent damage to the sheet steel by the heat. The top, doors, grates, legs, and base are made of cast iron. The US Army No. 1 space heater holds about 100 pounds of coal, and it will operate for several hours.

Most models of the magazine-type space heater are equipped with a heat exchanger. This is a large, oval-shaped sheet metal section (located at the entrance to the smokestack) helps make use of the heat that ordinarily is vented through the smokestack. The heat exchanger greatly increases the heater's efficiency.

The magazine stove uses a barometric damper in the smokepipe. This is a weighted damper that maintains a constant draft, regardless of wind and temperature; this damper helps prevent overheating and fuel waste.

Oil-Fired Space Heaters. In areas where oil

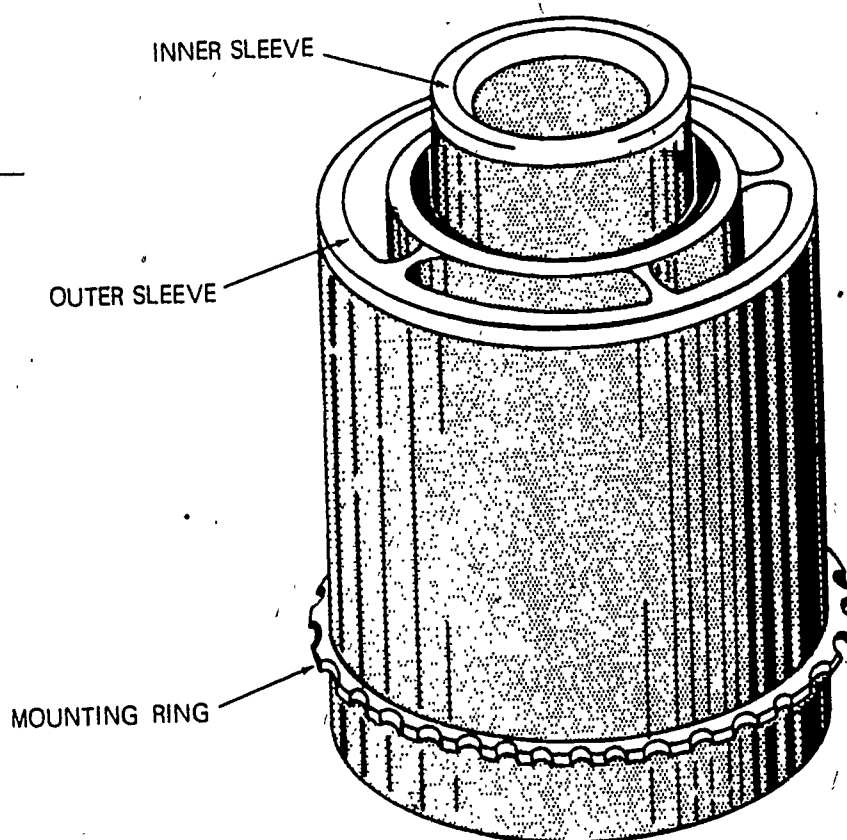


Figure 1-2. A sleeve-type distillate burner.

is the principal fuel, oil-fired space heaters are used for many space heating requirements. Essentially, they serve the same purpose as coal-fired units, but oil-fired heaters are of much lighter construction. Particular attention must be given to their care and proper maintenance.

Oil-fired space heaters are very simple in construction. They consist of a burner, a combustion chamber, an outer casing, a fuel tank, and a fuel control valve. An air space is provided between the combustion chamber and the outer casing. Air that enters through grilles in the bottom of the heater is heated and then passes out through the grilles in the top of the unit.

Some oil-burning heaters are equipped with a blower and electric motor that force the heated air into the room. The units turn at slow speeds and are either direct-drive or belt-driven.

Oil-fired space heaters have atmospheric vaporizing-type burners, two of which we describe next. These burners require a lightweight grade of fuel oil (generally No. 1 weight) that vaporizes readily at low temperatures and leaves only small amounts of carbon and ash. The two types of oil-fired space heaters in use are the perforated sleeve and the pot-type.

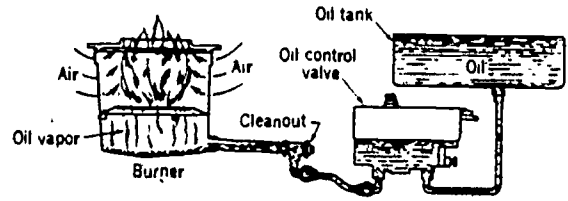


Figure 1-3. A natural draft pot-type burner.

Sleeve-type. The sleeve-type distillate burner is shown in figure 1-2. It includes a metal base formed of two or more circular fuel-vaporizing grooves and alternate air vaporizing channels. Also included are several pairs of perforated sleeves or cylinders; one is inside, the others are mounted on the metal base. Each pair of perforated sleeves forms a combustion chamber above its grooves. One or more cover plates that rest on top of the nested cylinders baffle the flame and close the air passage. This forces the air through the perforations into the oil vapor chamber. In this way a large number of air jets are introduced into the oil vapor, producing a good fuel mixture. The mixture burns with a clean, odorless blue flame.

These burners usually have a short asbestos kindling wick for ease in lighting. Some burners have a cup installed below the base so that alcohol can be burned to provide heat for

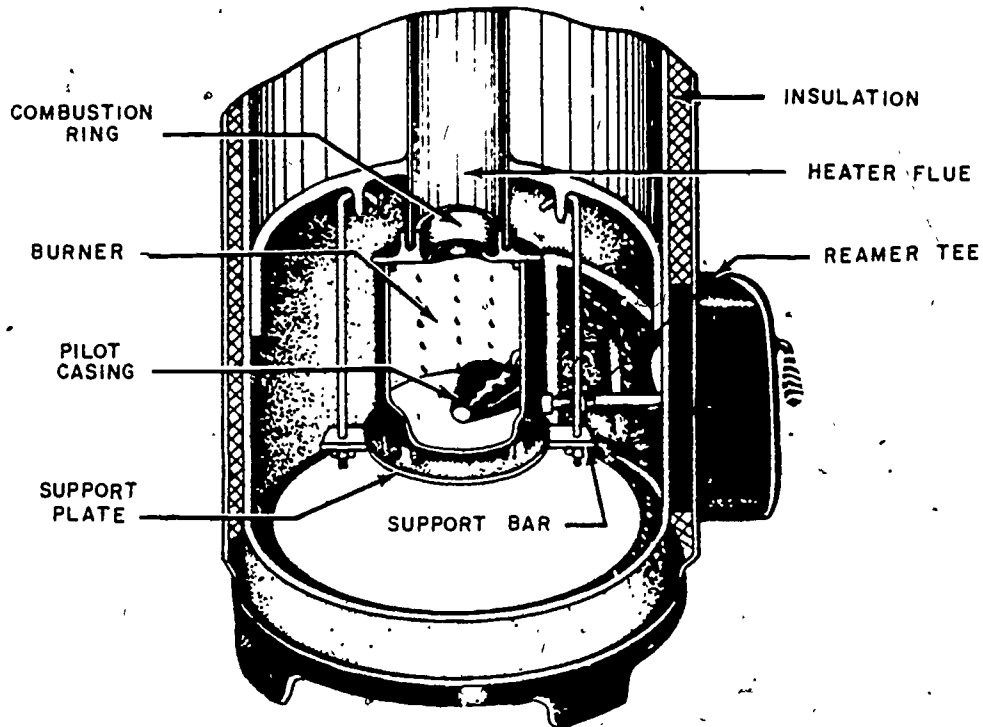


Figure 1-4. Cutaway of a natural draft pot-type burner.

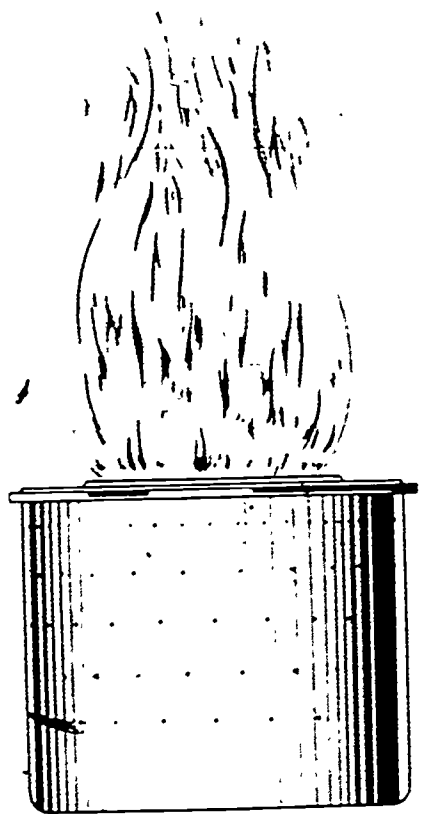


Figure 1-5. High-fire flame.

starting. The wick and the alcohol are used only for lighting.

Pot-type. Natural draft pot distillate burners are widely used for space heaters, room heaters, water heaters, and the like. They account for approximately 90 percent of all space-heating units in use. An illustration of the natural draft pot-type burner is shown in figure 1-3.

A closeup cutaway of the pot-type burner is shown in figure 1-4. In operation, the

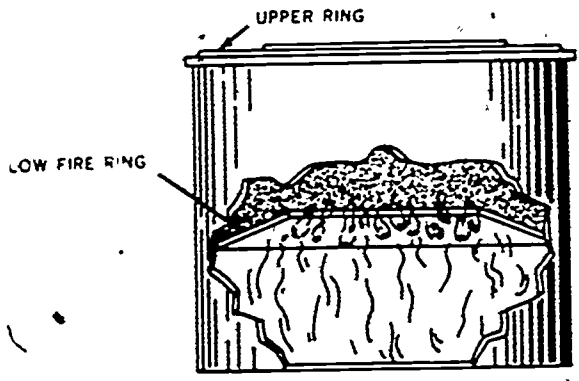


Figure 1-6. Low-fire flame.

distillate (oil) is fed in at the bottom of the burner or pilot casting, located either at the center or on the sides. The fuel is vaporized at this point by radiant heat from above. The vapors rise and are mixed with air drawn through the perforated holes in the burner. During high-fire conditions, the flame is above the top of the combustion ring as shown in figure 1-5. Under low-fire conditions, the flame burns in the lower portion or pilot ring of the burner, as shown in figure 1-6. The rate of distillate oil flow and method of ignition are often controlled manually.

Gas-Fired Space Heaters. Gas-fired space heaters can be used to satisfy specific heating requirements wherever gas is available. Gas space heaters are clean in operation, easily operated, and require no fuel handling. Natural, manufactured, or liquefied petroleum (LP) gases can be burned in these units.

Natural gas and manufactured gas are lighter than air. In case of a leak, such gases rise and drift away without much danger. However, liquefied petroleum gas, such as butane and propane, is heavier than air and collects and remains in low spots. This condition can easily result in health problems or a fire caused by sparks or carelessly discarded matches. For this reason, the leakage of LP gas is a hazard that must be avoided.

Gas-fired space heaters, using any of the gases mentioned, are of similar construction. They may be vented or unvented; that is, they may or may not be equipped with a pipe to carry away the flue gases.

Unvented gas space heaters. Unvented gas space heaters are usually of the open-flame type in which the gas burns in an open combustion chamber. These heaters should be used only in well-ventilated places so as to gradually remove the carbon monoxide and other gases produced by the gas flame.

Vented gas space heaters. The vented gas space heaters are of the inclosed type. They consist of a steel cabinet provided with top and bottom grilles or openings to facilitate the circulation of warm air. The flame burns in a closed combustion chamber, and the gases are carried away by the heater vent connected to the pipe. Space heaters of the vented type are more satisfactory than the unvented type, because there is less danger of carbon monoxide poisoning. A typical floor-type vented gas space heater is shown in figure 1-7.

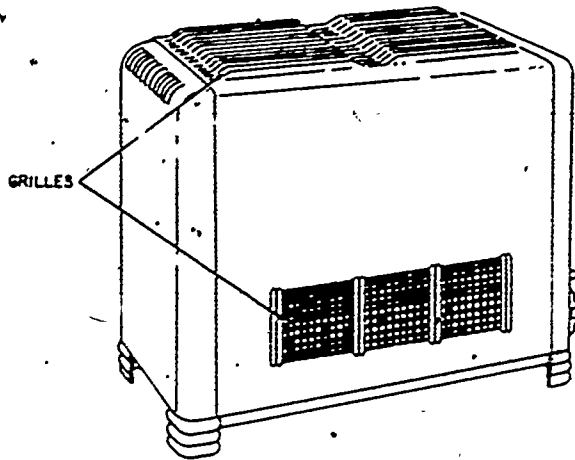


Figure 1-7. A typical floor-type vented gas space heater.

rating), length of pipe, and the number of fittings. The size depends also upon the allowable loss of pressure from the building entry to the space heater and the specific gravity of the gas. Capacity tables that show the flow of gas in pipes (cubic feet per hour) and the corresponding pressure drops are available in many handbooks.

Care should be taken to properly install the venting system for gas-fired space heaters, minimize the harmful effects of condensation, and insure that the combustion products are carried away by the pipe. Approximately 12 gallons of water are produced by burning 1,000 cubic feet of natural gas. The inner surface of the vent must, therefore, be heated above the dew point of the combustion products to prevent water from forming in the flue pipes. You install the vents with the male ends of the inner liner down, to return

Exercises (400):

1. Name the types of space heaters (according to fuel) used by the Air Force.
2. Match each of the following construction features with one of the specific types of space heaters that you listed in exercise No. 1.
 - a. Constructed of cast iron sections.
 - b. They may be vented or unvented.
 - c. Has a short asbestos kindling wick for lighting.
 - d. Major component parts include firepot, barrel, topneck, and topcollar.
 - e. Uses a barometric damper in the smokepipe.
 - f. Fuel is vaporized at pilot casting.

401. From the text and figures 1-11A and 1-11B, identify operating characteristics of space heating equipment. State some of the operating characteristics of space heating equipment.

Gas. If a unit is to operate properly, it must first be installed properly. All gas-fired space heaters and their connections must be of the type approved by the American Gas Association (AGA), and they must be installed in accordance with the recommendations of the AGA.

The gas line used to convey natural or manufactured gas to the space heater is usually black iron pipe. The size of the pipe used depends partially upon the maximum gas consumption of the heater (AGA name plate

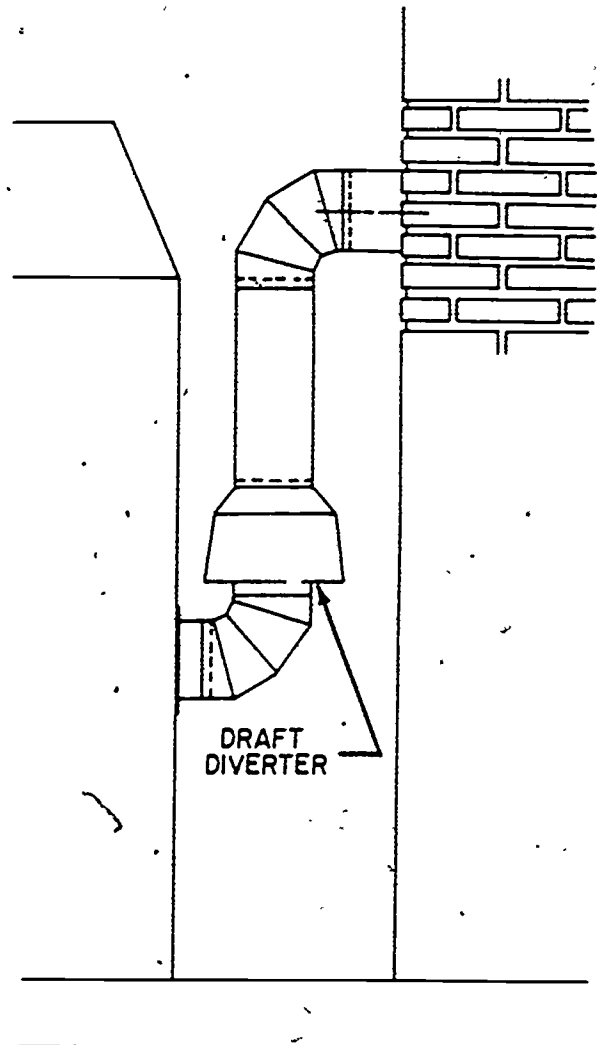


Figure 1-8. A typical draft diverter.

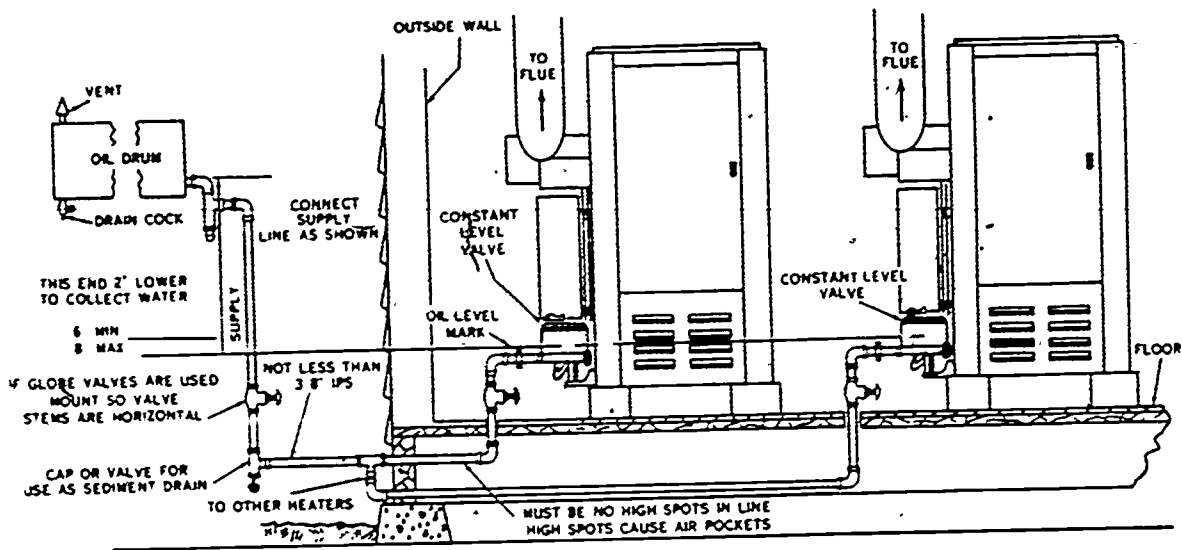


Figure 1-9. Space heaters installed in series.

condensation within the pipe during a cold start. Horizontal flue pipes should have an upward pitch of at least 1 inch per running foot.

Vents for combustible framing must be installed according to pertinent Air Force and local regulations. You construct the vents of material that is resistant to the corrosion caused by flue gas products, and install the same size vent pipe throughout the entire venting system. A vent should never be made smaller than the heater outlet.

Each gas-fired space heater should be equipped with a draft diverter or hood, such as that shown in figure 1-8. The diverter is a type of inverted cone through which the flue gases must pass on their way to the chimney. The cone also allows air from the heater room to be drawn into the flue pipe along with the flue gases. The purpose of the draft diverter is to prevent the chimney from producing an excessive updraft or downdraft condition. Either condition is apt to extinguish the pilot light or the main burner flame.

After a new installation has been hooked up, bleed the air from the gas piping and close the main gas valve on the heater and pilot cock to prevent filling the combustion chamber with gas. Then disconnect the pilot tubing outside the heater and open the valve supplying gas to the system so that the air will be expelled through the pilot line. When all air has been removed from the system, reconnect the pilot line. You should follow the proper sequence of this procedure to avoid accidents.

When you adjust the gas flame, you close the airmixer for the main burner until the flame is yellow, then open the shutter on the airmixer until the yellow disappears. Insufficient amounts of primary air cause the flame to burn yellow and produce sooting of the unit when the flame strikes the heating unit. Too much primary air causes inefficient operation, and this will sometimes cause the flame to pop back into the airmixer. This results in a yellow flame at the burner head.

Most of the gas-fired space heaters used by the Air Force are manually controlled. A pilot light is usually provided, and the heat is turned on or off by a hand-operated valve. When a pilot light goes out, the escaping lighter-than-air gas (natural or manufactured) rises through the vent and dissipates into the atmosphere. As before mentioned, heavier-than-air gas (liquefied petroleum) accumulates in the surrounding space and produces health and fire hazards. For this reason, 100-percent shutoff thermostatic pilots are required on space heaters using liquefied petroleum gas. The term "100-percent shutoff" means that the gas flow through the pilot, as well as through the main burner, is shut off automatically when the pilot light is extinguished. The 100-percent shutoff is operated by a thermocouple operating a cutoff valve.

Oil. Oil-burning heaters are portable and are easily moved from one location to another. To get satisfactory operation, follow the installation procedures supplied by the manufacturer. If both the pot-type and perforated-sleeve burners, oil is fed to the



burner under control of a float-operated metering valve. You must set the unit level so that the oil will be properly distributed in the burner. The fuel level control valve is the only safety device installed on the oil-fired space heater.

An oil supply from an outside tank to all heaters is often desirable when several space heaters are installed in a building. This eliminates frequent filling of individual tanks and reduces the waste from spilling. Figure 1-9 shows the principal elements of such a system, and it indicates the important points to consider during the installation.

Note that one end of the oil drum must be 2 inches lower than the other end to collect the water and permit its removal at the drain cock. The supply line from the tank must not be less than 6 inches or more than 8 inches above the oil level mark at the burner. A sediment drain must be provided in the supply line and the horizontal length of the line must not have high-spots that will cause air pockets.

The heater should be placed the same distance from the wall as a coal-fired heater. It should have a pan made of sheet metal to sit in; this will catch the oil if a leak occurs. A sandbox or cement must not be used as both the sand and cement will absorb oil and create a fire hazard.

When the oil control valve is opened, the oil enters the burner at the bottom of the pot and a torch is used to ignite it. As the oil begins to burn and vaporize, the vapors rise and mix with the air entering through the perforations in the side of the pot. The position of the flame inside the burner depends on the amount of vapor produced and the amount of vapor produced depends on the oil level in the pot. When large quantities of oil are being vaporized, the flame stands high on the top ring, as shown in figure 1-10, detail A. The vapor travels to this point before enough air is mixed with it to produce complete combustion at this high-firing rate. The medium-firing rate flame is shown in figure 1-10, detail B. The

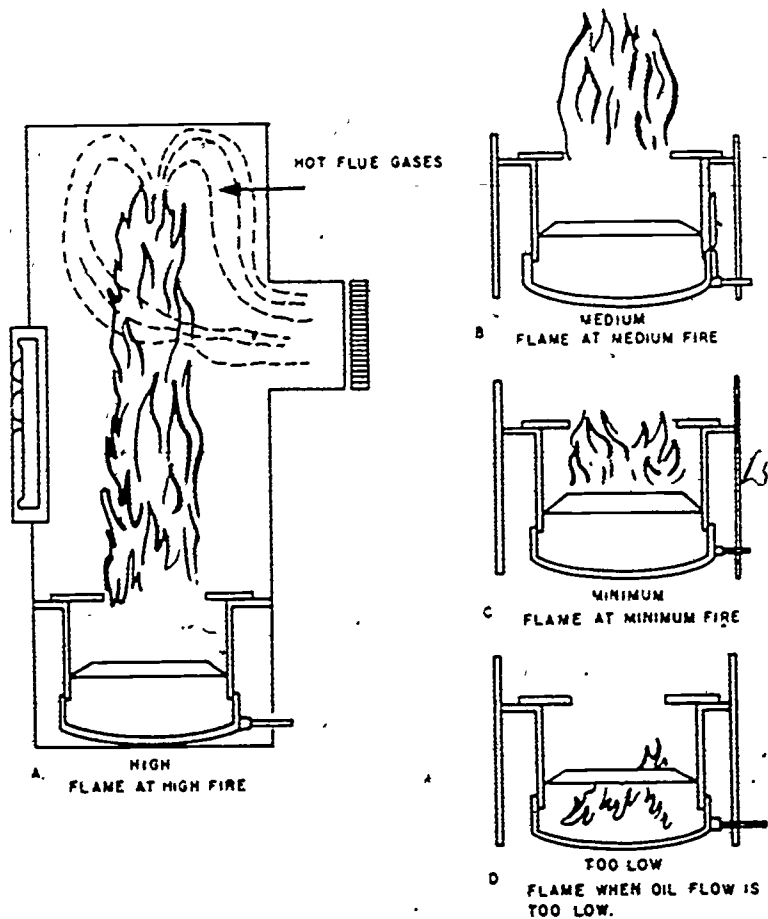


Figure 1-10. Position of burner flame at different rates of fuel flow.

BURNER WILL NOT LIGHT

Probable Causes

Air trapped in the oil supply lines.
(This condition can be caused by a combination of air leaks and high points in the supply line.)

The oil control valve might not be level.

The oil might be too heavy.

Dirt in the oil supply line.

Dirt in the metering mechanism

A clogged oil strainer.

Sludge clogging the supply line.

The fuel inlet clogged with carbon.

Remedies

Eliminate the high points in the piping, correct leaks and bleed the line.

Level the valve.

Use the grade of oil recommended by the manufacturer.

Clean the supply line.

Clean the metering mechanism.

Clean the strainer.

Clean the supply line.

Remove the carbon.

BURNER SMOKES

Probable Causes

Improper fuel.

Insufficient oil flow.

Excess chimney draft.

Pilot casing is poorly fitted to the casing.

The burner needs cleaning.

Excessive flue downdraft.

Remedies

Use the grade of fuel recommended by the manufacturer.

Troubleshoot for low oil flow.

Check the draft regulator for proper operation.

Remove and install the pilot casing properly.

Clean the burner.

Modify the chimney height as required, or install a downdraft hood.

Figure 1-11A. Troubleshooting oil-fired space heaters.

minimum or low-firing rate flame is as shown in figure 1-10, detail C.

Figure 1-10, detail D, shows the effect when the flow of oil into the pot is too slow. The vaporization and combustion takes place at the bottom of the pot. Air to support this combustion enters above the lower ring. When combustion occurs below the lower ring, except during starting, the oil flow rate is insufficient. In this case, increase the oil flow rate or shut the heater off. If the flame stands too high above the burner or extends into the flue pipe, the rate of oil flow is too great. In this case, decrease the rate of flow to prevent

dangerous overfiring. Some of the common causes of troubles encountered during operation or troubleshooting are listed in figures 1-11A and 1-11B.

Exercise (401):

State some of the operating characteristics of space heating equipment by supplying answers to the following questions.

1. Why must an oil-fired space heater be level if it is to operate properly?

Burner Goes Out

Probable Causes	Remedies
Low oil supply.	Add oil if necessary.
Plugged vent on the oil supply tank.	Clean the vent.
Insufficient oil flow.	Troubleshoot for low oil flow.
Improper fuel.	Use fuel recommended by the manufacturer.
Fuel inlet plugged with carbon.	Clean the fuel inlet.
Dirt in the oil control valve.	Clean the valve.
Oil valve is not level.	Level the valve.
Filter cartridge is plugged with sludge and dirt.	Clean the filter.
Excessive chimney draft.	Check for proper operation of the draft regulator.
Excessive flue downdraft.	Modify the chimney height as required, and install a downdraft hood.

Burner Flooded

Probable Causes	Remedies
Dirty float valve.	Remove and clean the float valve.
Improper operation.	Instruct operating personnel on the proper procedures of operation.
Needle valve stuck.	Clean or replace the needle valve.

High Fuel Consumption

Probable Causes	Remedies
Improper fuel	Use fuel recommended by the manufacturer.
Heat loss.	Reduce the supply of air to the burner.
Heat exchanger areas caked with carbon and slag.	Clean the caked areas.
Excessive chimney draft.	Check the operations of the draft regulator.

Figure 1-11B. Troubleshooting oil-fired space heaters.

2. What is the most likely cause of a correctly installed pot-type burner going out?

6. Explain the term 100-percent shutoff.

3. What is done to gas-fired space heaters to indicate that they have been approved?

402. State the purpose of the fuel oil control valve and identify the component parts.

4. A natural gas space heater burns 500 cubic feet of gas in 24 hours. How much water is produced in the burning process?

The oil control valve, shown in figure 1-12, is the only control device on the oil-fired space heater. The main purpose of the oil control valve is to meter a precise amount of fuel oil to the burner pot.

5. What color is a gas flame when too little air is furnished to the flame?

The strainer prevents any impurities in the fuel oil from entering the oil control valve. The inlet needle valve stops and starts the flow of oil to the valve and during operation is controlled by the oil temperature compensating float. The purpose of the oil temperature compensating float is to maintain a specific and constant amount of oil within

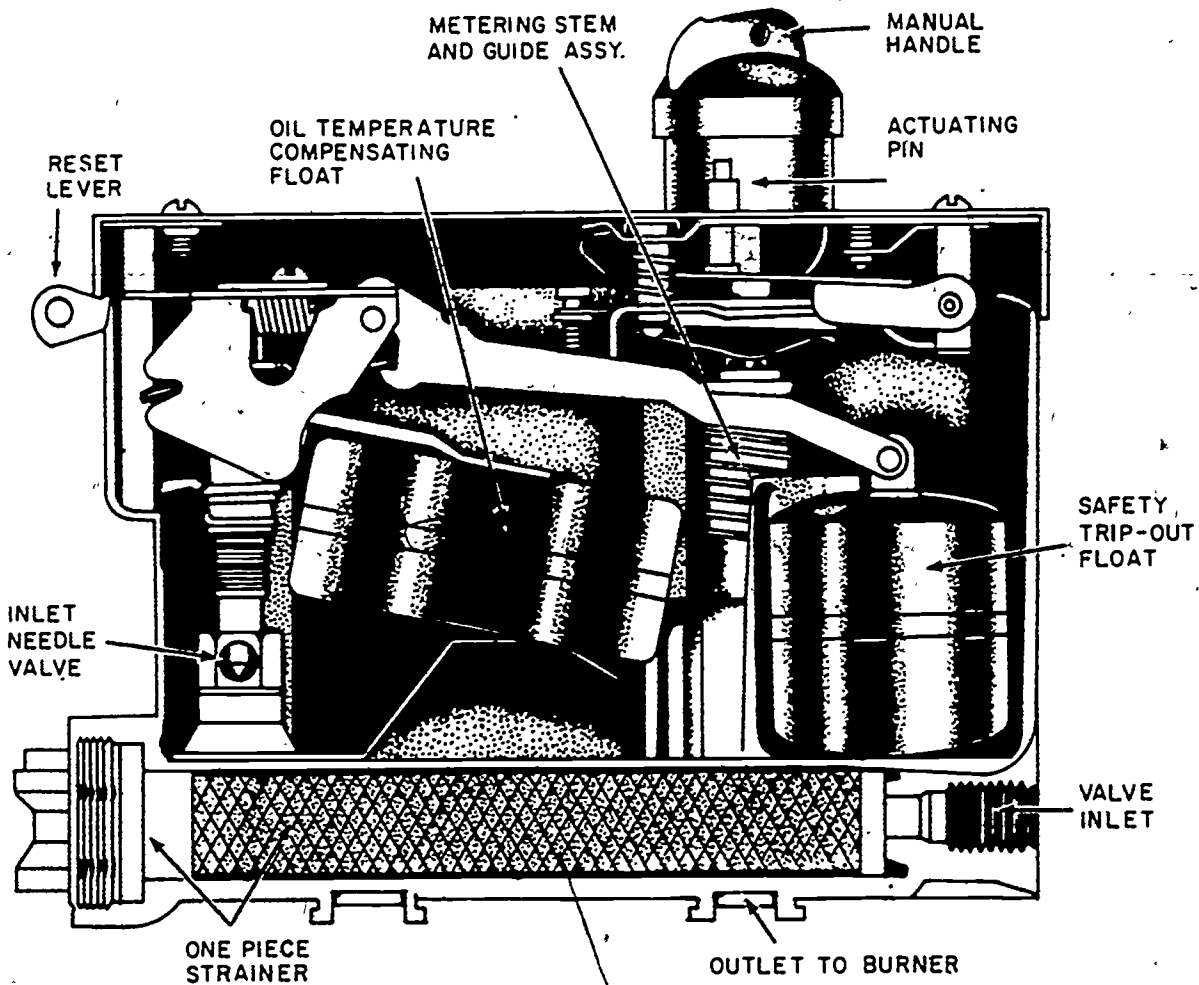


Figure 1-12. Oil control metering valve.

the valve. The reset lever is a manual safety built into the oil valve. During periods the heater is not in operation, the reset lever is in the up position. This puts pressure on the inlet needle valve and holds it in the closed position so that no oil will enter the valve. During operation of the heater, the reset lever must be in the down position. This removes the pressure from the inlet needle valve and allows oil to flow to the valve. The manual control knob, located on top of the oil control valve, is the adjustment for the oil flow rate. The valve is calibrated to allow so much oil to pass through on low fire and high fire, and the different setting of the control knob will either increase or decrease oil flow rate somewhere between the low and high fire setting. As the control knob is turned from the low position to the high position it raises the metering stem allowing more oil to flow through to the burner. The safety tripout float is an automatic safety that will trip the reset lever, closing the needle valve and stopping oil flow into the valve. The safety tripout float is actuated by high oil level within the valve. This safety device will provide 100-percent shutoff of oil in case of high oil level within the valve.

The most important part of the oil control valve, even though it has nothing to do with the operation, is the nameplate, mounted on top of the valve by four screws. On this nameplate is the manufacturer's name, operating instructions, and the maximum and minimum flow rates (for calibration purposes) stamped on the plate in cubic centimeters per minute (the measurement used for calibration). This nameplate should be mounted on the valve at all times except when performing maintenance on the valve. Figure 1-12 shows the component parts of an oil control valve.

Exercises (402):

1. State the purpose of the fuel oil control valve installed on a space heater.
2. Using figure 1-12, list the component parts of a space heater fuel oil control valve.

403. State the causes for a gas burner to produce soot and specify the maintenance tasks performed on space heaters.

Oil. Maintenance services should be accomplished in accordance with AF Regulations, manufacturer's specifications, or local directives, to insure the proper operation of burners. Here are some of the common services that should be performed on pot- and sleeve-type space heaters during preventive maintenance.

Remove the soot and carbon from the burners, heat-exchangers, and chimneys. Ream and clean out the oil inlet; also, clean the oil storage tanks, the oil supply lines, and the strainers in the oil supply lines. Lubricate the blower motors, clean the lighting pilot, and check all the electrical wiring on forced-draft oil burners. Also clean and adjust the oil level control.

The oil level control valve is an important part of the space heater, so it is necessary that it function properly. To obtain satisfactory results and uninterrupted service, give regular attention to its periodic maintenance. The following suggestions are tips for doing this type of maintenance. Avoid letting dirt or water accumulate on or in the valve; clean the screen regularly. Also, avoid letting dirt or water mix with the oil. Make sure that the oil tanks are clean before they are filled. Do not use the valve assembly as a handle for lifting the heater. Before you service the oil level control valve, make sure that the oil supply is cut off.

The detailed procedures for accomplishing the maintenance that is required can be found in applicable technical literature covering the specific installation.

Gas. Gas-fired space heaters should be inspected and maintained according to a schedule prescribed by AF Regulations or local directives. The chimney and pipe should be examined from the outside as well as the inside of the building. Any noticeable deterioration such as rusting, broken guy wires, and the like, should be reported.

To clean a gas-fired space heater, you will have to remove the casing, pipes, and burner. Some elements can be cleaned by simply tapping them with a piece of wood to loosen the soot. The soot can then be removed by running the flexible suction hose from a vacuum cleaner through the unit. When you use air pressure to blow out the soot, you should first move the heater out of the building.

Gas burners and heating elements will soot up when foreign matter in the venturi tube interferes with the proper flow of gas and air. This causes the flame to burn yellow. To correct this difficulty, you must take out the venturi tube and burner head, and remove the obstruction.

Usually, a yellow flame is caused by insufficient primary air. Perhaps this is due to improper adjustment at the airmixer, or to lint or other matter being lodged against the opening around the airmixer. You simply adjust or clean the airmixer to remedy these difficulties.

Exercises (403):

1. What normally causes a gas burner to produce soot?
2. The flame of a gas burner is normally what color when soot is produced?
3. Specify the maintenance tasks you perform on oil-fired space heaters.

1-2. Fundamentals of Installation

The location and elements of proper installation for space heaters was covered in the preceding learning objectives. Now we will cover the proper installation factors involved in installing space heaters to chimneys and stacks.

404. Explain how draft is created in a chimney and determine stack height for a given situation.

Draft in a chimney is created by the difference in weight between the hot air or gases inside the chimney, and the cold air on the outside. Hot air always rises; consequently, the hot gases produced by combustion will rise in the chimney and cause cold air to be drawn into the heater to replace it. This continuous action of the hot air rising in the chimney and being replaced by cold air drawn through the stove or heater is called

draft. In cold weather, the draft may be stronger, because of the much colder air outside the building; whereas in summer, the draft is less due to the smaller difference between the temperature (and weight) outside the building and that inside the stack.

It is necessary for the heating specialist to know how to make repairs affecting draft. All heating equipment should have a properly constructed chimney. The chimney should be made smoketight throughout and should have the flue area and height that are in accordance with heat engineering practices. Too many times the heating equipment is blamed when the fault lies entirely with draft conditions in the chimney. If the equipment is being installed in an existing structure, the chimney should be examined and reconditioned as necessary. It should be extended at least 3 feet above the highest point of the roof or any other structure or obstruction within 30 feet of it.

The main types of stacks are: steel, masonry, and reinforced concrete. All types usually have some means of cleaning ash and soot from the base of the stack. Steel stacks may be either self-supporting or guyed, lined or unlined. They are usually lined with insulation to protect the metal from gas corrosion and erosion and prevent loss of draft due to cooling the gas. Masonry stacks are generally built with special radial bricks or blocks. Normally, they are lined with firebrick up to one-fifth of the height and protected from lightning. They are higher in initial cost than steel stacks, but have a longer life. Reinforced concrete stacks are normally used for large installations. These stacks are also lined for adequate protection from lightning.

Exercises (404):

1. Explain how draft is created in a chimney.
2. You are installing an outside chimney or stack. The roof is 25 feet high at the peak. A 30-foot building is 20 feet away and a 60-foot tree is 35 feet away. How tall should the chimney be?

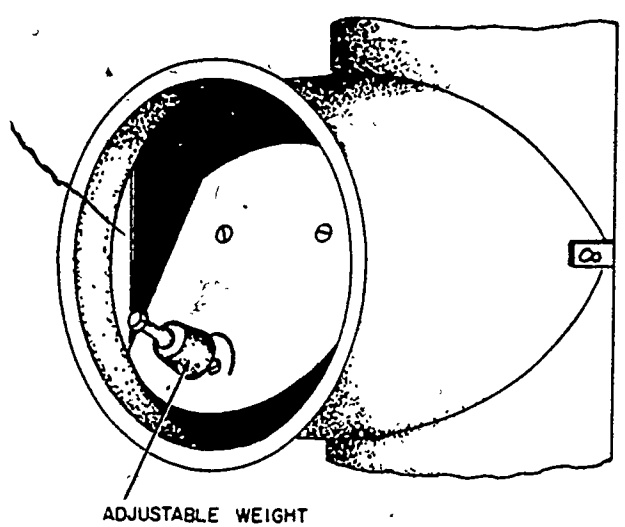


Figure 1-13. Draft regulator.

405. Explain the purpose of counterweight on a draft regulator and state the purpose of the draft regulator installation.

Since the flow of air to vaporizing type burners depends on the chimney draft, pay careful attention to this feature. Poor draft will result in a smoky flame that produces little heat, while a downdraft will make it almost impossible to keep the flame going at all.

The barometric damper is the simplest type of draft regulator. This automatic type of damper is usually installed in the first point of the stovepipe where the pipe leaves the heater. It can also be installed in the breeching, or at the base of the stack or chimney. It consists of a balanced swinging damper (weighted butterfly), which is sensitive to changes in the draft intensity. Figure 1-13 is an illustration of a draft regulator.

Automatic and proper operation of a draft regulator depends upon correct installation, because the regulator must balance correctly and be free to move at the slightest change in draft pressure. Regardless of whether the regulator is installed in a vertical, horizontal, or angled smokestack, the top of the damper must be at the true top position. The face must be plumb (straight up and down). When the regulator is used in a horizontal or nearly horizontal pipe, the counterweight is not used.

This regulator acts as a balanced air valve that admits air to the flue pipe to maintain a constant draft in the furnace.

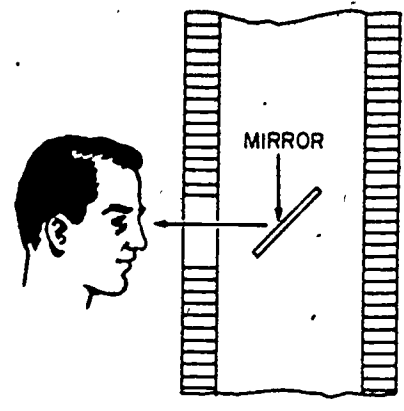


Figure 1-14. Visual inspection of chimney.

Exercises (405):

1. Why is a counterweight used on a draft regulator?
2. State the purpose of installing a draft regulator on a vaporizing type burner.

406. From given information, select the factors considered for connecting or inspecting outlets connected to flues or stacks.

Knowing the principles on which good draft depends, and assuming that the space heater will be connected to a well constructed chimney, the following factors should be

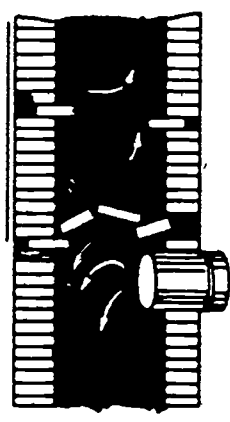


Figure 1-15. Obstructions in chimney.

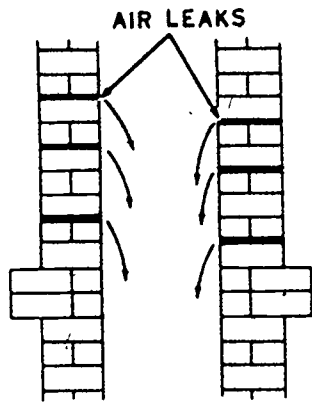


Figure 1-16. Loose brick.

ash, fallen or displaced bricks, or bird's nests, etc. If a condition such as this is found, a heavy weight suspended from the top of the chimney dropped down from the top of the chimney will often clear these obstructions. If they cannot be cleared in this manner, then obtain the services of an experienced chimney man. Figure 1-15 shows obstructions in a chimney.

See that all openings in the chimney are tightly closed. Look for caps that do not fit tightly in the unused opening into the chimney. Usually at the base of every chimney there is a cleanout door or opening to permit the removal of soot or accumulated fly ash. Often these will be found partially open or rusted out. Close tightly or replace. See that any unused stoves or heaters connected to the chimney have all dampers closed tightly, including the chimney damper, as much of the effectiveness of the chimney can be lost by these larger air leaks. Next, examine the chimney at every point possible to see that none of the mortar between the bricks has fallen out. Leaks of this kind can cause an otherwise good chimney to give a poor draft. See that all joints between the bricks are cemented and made airtight. Figure 1-16 illustrates loose bricks with air leaks.

considered in making the smokepipe connection.

1. Make connection from heater to chimney short as possible.
2. Install with a pitch upward of not less than 1 inch per running foot of length.
3. Avoid sharp turns or other constructional features that would create excessive resistance to the flow of gases.
4. Place smoke pipe so as not to enter beyond inner wall of chimney flue.

In order for a heating specialist to be able to be sure of his work in installing flues, he must be able to recognize some of the common faults and how to correct them.

First examine the chimney by use of a hand mirror placed at the proper angle in the cleanout door at the base of the chimney, or at the opening provided for the smokepipe as illustrated in figure 1-14. This will show if the flue is clear or if it has been obstructed by fly

Oftentimes a downdraft is created by either a high tree or any adjacent taller building as illustrated in figure 1-17. In each of these cases, a downdraft hood will eliminate this condition. In this case, the chimney is too short and when the wind blows from the opposite side of the house, a downdraft is created in the chimney. Increase the height of the chimney to approximately 3 feet above the ridge of the house or install an approved

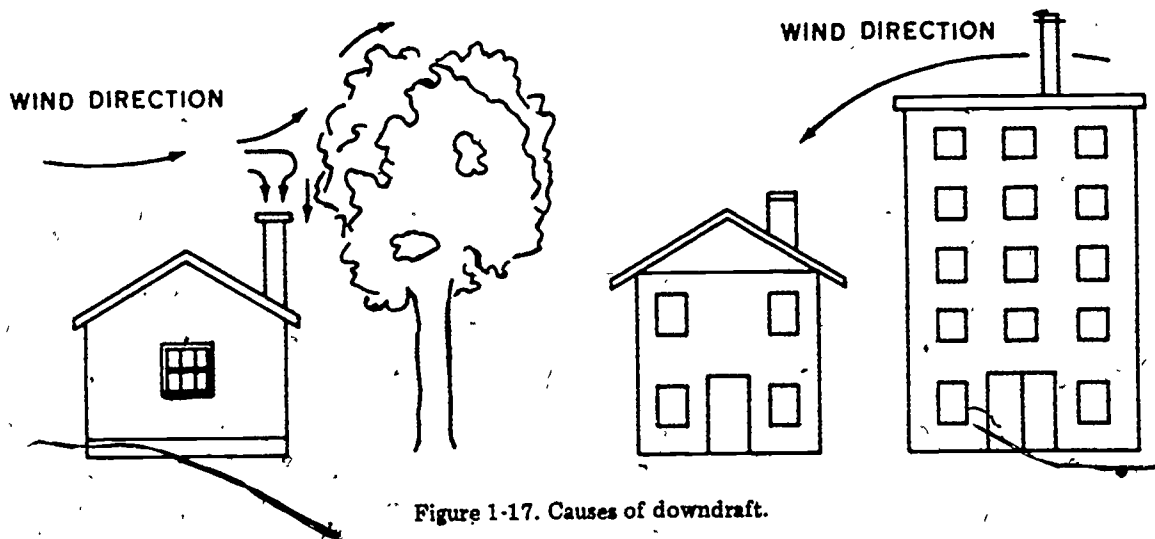


Figure 1-17. Causes of downdraft.

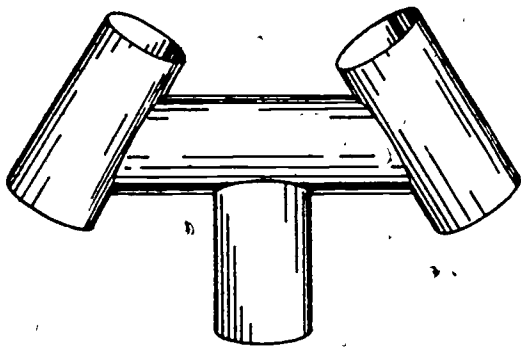


Figure 1-18. H-type hood.

downdraft hood on top of the present chimney. Downdraft may seriously interfere with properly functioning burners. Downdraft may result when the chimney is not high enough for the building roof line or is too close to other high buildings, trees, or terrain features (fig. 1-17). The chimney must be at least 3 feet above the highest point of the building roof. If the difficulty is caused by other factors, a downdraft hood may prove effective. Two types of downdraft hoods are the A and H. Figure 1-18 illustrates a H-type hood.

Another source of trouble is a chimney opening that is smaller than the smokepipe connected to it. The chimney opening should be larger. Never reduce the size of the smoke pipe before entering the chimney. The fluepipe should fit tightly at all connections and should pitch slightly upward throughout its entire length until it enters the chimney. An upward slant of one inch per joint is about right.

Sluggish chimneys can sometimes be remedied by the use of a toothpick joint as illustrated in figure 1-19. When a chimney has too large a flue or a weak draft, attach this joint to the smokepipe and let it extend into the flue so that point "X" is in approximately the center of the chimney.

Some chimneys are built on a shelf, as shown in figure 1-19, the bottom of which is only a few inches below the smoke pipe opening. A strong eddy current is usually formed at the bottom of the chimney, and the toothpick joint will assist in creating a good draft.

Exercises (406):

From the following information, select the factors that are considered when inspecting or

connecting exhaust outlet to flue or stack connections. Place an X in the blank provided if the statement is one of the considered factors.

- 1. Heater to chimney connection should be short.
- 2. Install pipe with a downward pitch.
- 3. Install pipe with an upward pitch.
- 4. Use 90° turns whenever possible.
- 5. Smoke pipe must not enter beyond inner wall of chimney flue.
- 6. Smoke pipe must enter beyond the inner wall of the chimney flue.
- 7. Use a flashlight to inspect the flue.
- 8. A hand mirror placed in the cleanout door is used to inspect the chimney for obstructions.
- 9. Check status of unused stove or heater dampers.
- 10. Check chimney height to insure it is at least 3 feet higher than any close object.
- 11. Use a toothpick joint to assist in creating a good draft.

407. Fundamentals of Unit Heaters

One of the most common types of heating units that you will be working with is the unit heater. This factory-made assembly of all major elements is ready for immediate installation.

407. State how unit heaters are identified and identify the types of unit heaters. Also match each type of heater to the way it is rated.

Unit heaters are identified by their source of heat, such as steam or hotwater, electricity, gas, and oil. They may be further distinguished by the type of fan, such as

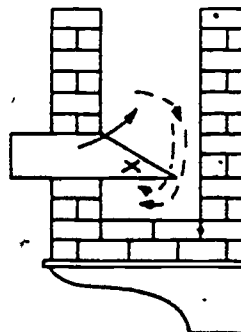


Figure 1-19. Toothpick joint.

propeller or centrifugal that provides circulation, and also according to the arrangement of these elements. In the "draw-through-type" the fan draws air through the heating element; in the "blow-through-type", it blows air through the heater. Either type may be arranged for horizontal or vertical delivery of air.

Rating Unit Heaters. As a rule, standard practice is to rate unit heaters on the basis of the amount of heat in Btu per hour delivered by the heated air (above 60° F.) that enters the heater. However, for comparison purposes, other factors must be considered.

Steam. Steam unit heaters are rated at psig entering steam and 60° F. (29.92 in. Hg barometric pressure) entering air, when the heater operates without external resistance to airflow.

Electric. Electric unit heaters consist of electric resistance heating elements, assembled with a fan motor in a suitable casing. These heaters are rated in terms of the energy input to the heater expressed in kilowatts, Btu per hour, or equivalent direct radiation (EDR—a unit of heat delivery equal to 240 Btu per hour). They are available in sizes up to 60 KW capacity.

Gas-fired. Gas-fired unit heaters are rated in terms of both input and output, according to the requirements of the American Gas Association.

Oil-fired. Oil-fired heaters are rated in terms of heat delivered at unit outlet, expressed in Btu per hour.

Influence of Airflow Resistance on Capacity. Unit heaters are usually rated in terms of free delivery of air. If free airflow is obstructed by air filters, outside air intakes, or ducts on the inlet or discharge side, a reduction in air delivery and heating capacity results. The amount of capacity reduction depends on the characteristics of the unit, and the type and design or obstructions. Obtain from the manufacturer the heat output that can be expected under other than free delivery conditions. Some unit heaters provide both space heating and ventilation. Because the amount of air required for heating purposes usually exceeds that required for ventilation, part of the heated air can be recirculated, thereby improving economy. The position of a recirculating air damper at the heater's cold air inlet determines the amount of air recirculated. The outside air drawn in by the heater fan mixes with the recirculated air. This air mixture then passes through the heating elements and discharges to the heated area.

Exercises (407):

1. State how unit heaters are identified and identify the types.
2. Match the unit heaters in column A with the appropriate rating in column B by writing the correct letter(s) in the blank provided.

Column A	Column B
1. Steam _____	a. Expressed as Btu per hour.
2. Electric _____	b. Rated at entering steam psig and 60° F. entering air.
3. Gas-fired _____	c. Kilowatts or equivalent direct radiation.
4. Oil-fired _____	d. Rated in terms of both input and output.
	e. Rated in terms of free delivery air.

408. Tell how a unit heater is controlled, and given unit heater operating principles and maintenance tasks, match them to the applicable unit heater in operation.

Operation Control. A unit heater can be automatically controlled by thermostatic control of fan action or control of the heating-medium flow. Unit heaters that provide both heating and ventilation (see Learning Objective 407) usually have a control system to vary the heating and cooling effect while the fans are operating. A room thermostat that controls both a regulating valve and a damper usually provides temperature control. The regulating valve governs the flow of heating medium to the heating element; the damper regulates the ratio of cool outside air to recirculated room air in the airmixture that flows through the heater. The operating cycle of the unit ventilator-heater consists of three main periods.

Rapid warmup. The controls provide rapid warmingup. With heating valve wide open and the damper closed to prevent entrance of outside cool air, room air (100-percent) is recirculated and heated until the desired temperature level is approached.

Heating. As the room temperature approaches the desired level, the control system operates the recirculating damper to vary the ratio of outside cool air to recirculated room air. Simultaneously, the regulating valve is throttled to control the

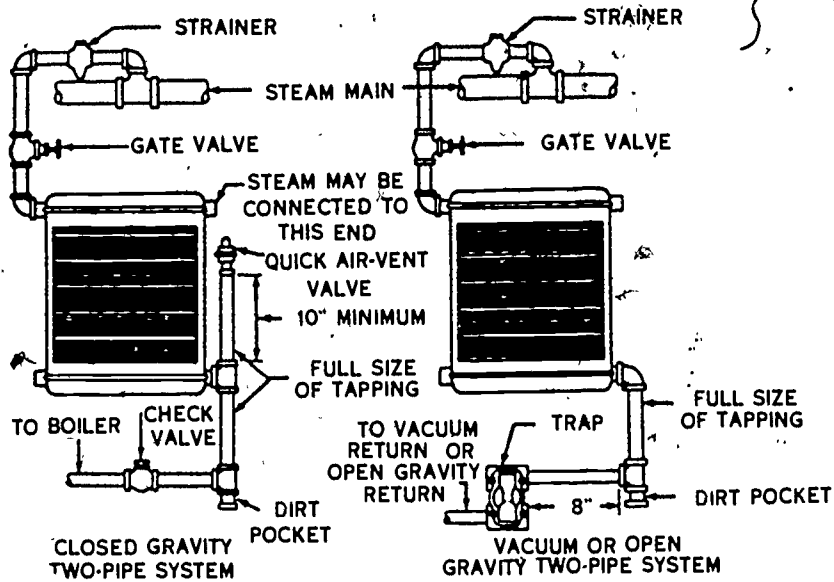


Figure 1-20. Steam unit heaters.

heat supply. The combined effect of the damper operation and the throttled regulating valve maintains the desired temperature level.

Cooling. If the room temperature rises above normal, the room thermostat actuates to completely close the valve. Then, it keeps moving the damper until 100-percent cool air operation is obtained, if necessary. Usually, the unit has control devices that prevent delivery of air cool enough to cause cold drafts. This can be accomplished by an insertion thermostat located in the air stream beyond the heating element. Frequently, the insertion thermostat is set at 60° F. and takes control to prevent the discharge of objectionably cold air.

Steam Heater Operation. Unit heaters used in steam heating systems, shown in figure 1-20, are similar to those used for hot-water heating. Steam enters the unit heater at the top and gives off heat to the finned tubes of the radiator. The circulating fan forces the air to be warmed through the finned tubes and at the same time causes the air to circulate in the space to be heated.

There are two types of unit heaters as shown in figure 1-20; the closed gravity two-pipe system and the vacuum or open gravity two-pipe system. The closed gravity system must have a quick air-vent valve at the heater to relieve air in the system, and requires a check valve in the steam return line. The vacuum, or open gravity system has a special trap in the steam return line and automatically vents itself.

Starting up (new installation). Check motor and fan rotation and see that bearings are properly lubricated. Gradually admit steam to the coils and blow down the unit to remove accumulations of grease and other materials found in new piping systems. Start the fan and feed steam to the coils by proper valve operation; assure that the steam trap is working correctly, and see that air is being vented properly.

Normal operation. Maintain adequate steam flow at correct pressure to develop rated capacity. Check operation of steam trap and air vent. Check motor and fan operation for excessive noise and abnormal vibration and temperature. If a space heater fails to heat satisfactorily, check the following.

- **Speed of The Motor.** A unit running at a speed below normal delivers less air. See that heated air is passing through the unit in sufficient quantity to deliver its rated capacity.
- **Steam Flow.** Make sure that the proper amount of steam to fulfill capacity requirements is flowing through the coils at the correct pressure. See that all required valves are properly open, that the coils are free of air pockets, and that there is no obstruction or stoppage of the flow.
- **Steam Pressure.** The steam supplied to the unit should be at rated pressure. This will determine the steam temperature.
- **Space Heat Loss.** If the unit is delivering its intended capacity, check the space heat loss and see if it exceeds the capacity of the heater.

• **Location of Heater.** There are horizontal and vertical distance limits in the location of heaters. Location affects blow and coverage of the unit. Check manufacturer's instructions and charts.

Hot-Water Operation. A unit heater can be a heating coil supplied with hot water used to heat a localized area. Coils are usually of the finned type, and air is circulated over them by an electric fan. A unit heater installed in a distribution main is illustrated in figure 1-21. Note that if the inlet piping is slanted downward towards the heater, an air vent is not required. An electric circulator pump in the return line is connected to operate simultaneously with the heater fan to assure adequate water removal.

The maintenance of unit heaters includes a monthly inspection for water leaks, cleanliness of the finned coils, and the operation of the fan motor. Other accessories that should be inspected are the air vents, fan blades, and valves. Make repairs accordingly. Lubricate the electric fan motor monthly.

Starting up. As you did with the steam heaters, check motor and fan rotation and see that bearings are properly lubricated. Gradually admit hot water to the coils and blow down the unit to remove accumulations of grease and other loose materials found in new piping systems. Start the fan and see that normal speed (revolutions per minute) is earned. After piping is cleaned, supply hot water to the coils by proper valve operation.

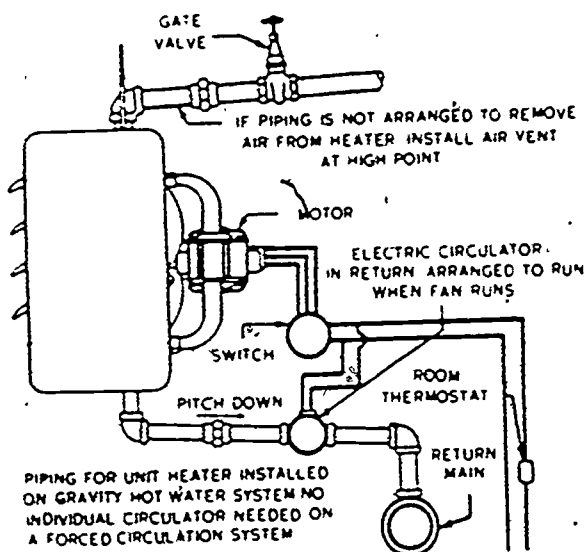


Figure 1-21. Hot-water unit heater.

Normal operation. Maintain adequate flow of water at a correct temperature to develop rated capacity. Check motor and fan operation for excessive noise and abnormal vibration and temperature. If spaces fail to heat satisfactorily, check the following.

• **Motor Speed.** A unit running at a speed below normal delivers less air. See that heated air is passing through the unit in sufficient quantity to deliver rated capacity.

• **Water Flow.** Make sure correct amount of water is flowing through the coils to fulfill capacity requirements. See that all required valves are open, that the coils are free of air pockets, and that there is no obstruction or stoppage of flow. Check water pressure.

• **Water Temperature.** Water supplied to the unit should be at rated temperature.

• **Space Heat Loss.** If the unit is delivering its intended capacity, check the space heat loss and see if it exceeds the capacity of the heater.

• **Location of Heater.** There are horizontal and vertical distance limits in the location of heaters. Location affects blow and coverage of the unit. Check manufacturer's instructions and charts.

Gas-Fired Heater Operation. Air for combustion enters the combustion chamber through openings in the bottom (natural convection). At the same time, the fan forces the air to be heated across the radiator, where heat from the combustion products is transferred to the air. The airstream is directed by the outlet louvers, while the flue gases leave the heater through the rear flue connection. A gas-fired heater is illustrated in figure 1-22. Gas-fired unit heaters have the same controls as other gas units. They include a safety pilot, thermocouple, automatic (magnetic) gas valve, and thermostat. A limit switch is provided to protect the unit from an over-temperature condition. The operation of one complete cycle is as follows:

When the thermostat calls for heat, it makes a circuit that opens the magnetic gas valve. This allows gas to flow into the burner that is lit by the pilot. As the temperature rises in the heater, a thermo-element (preset) makes a circuit to the blower or fan. This fan blows air across the heat exchanger into the space to be heated.

As soon as the thermostat is satisfied, the circuit to the magnetic gas valve is broken. This causes the valve to close, securing the fire. The fan continues to run until the temperature within the heater drops to the low (fan off) setting.

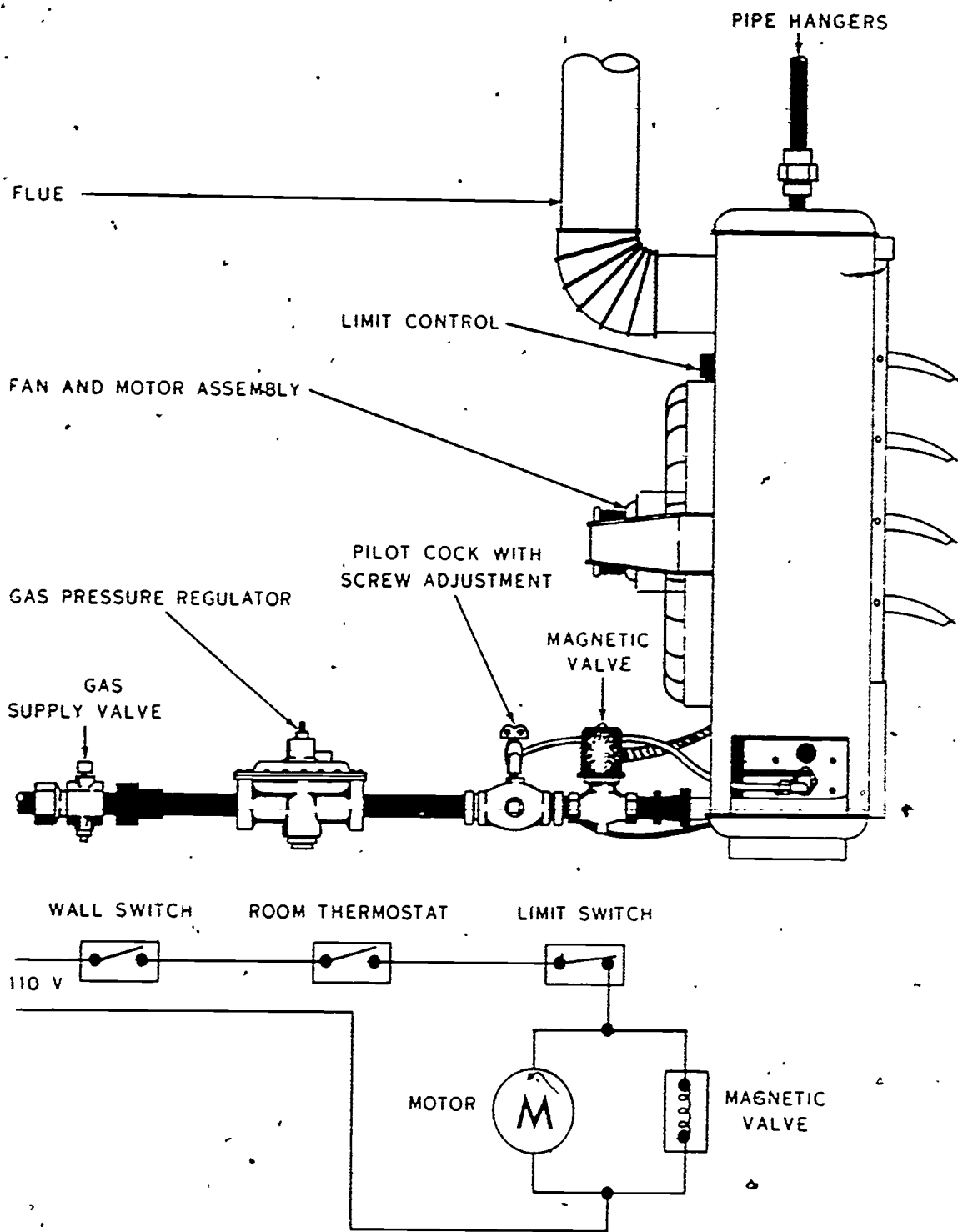


Figure 1-22. Gas-fired unit heater.

Exercises (408):

1. How is a unit heater controlled?

2. Match the unit heater in column A to the operating principles or maintenance tasks listed in column B by writing the correct letter in the blank provided. Column B items may be used once, more than once, or not at all.

- Column A**
- 1. Steam heater
 - 2. Hot-water heater
 - 3. Gas-fired heater

- Column B**
- a. Circulating fan forces air to be heated through finned tubes.
 - b. Check motor speed.
 - c. The burner is lit by a pilot.
 - d. Check motor and fan rotation.
 - e. During operation check the trap and air vent.
 - f. The burner is lit with a torch.
 - g. Check cleanliness of finned coils.
 - h. The fan will run until temperature drops to the low setting.
 - i. Check space heat loss.

409. Cite the considerations for selecting the unit heater and specify the locations for steam, water, gas, electric, and oil heater installation.

Applications. When selecting unit heaters, consider the heating medium, air distribution, and location of the unit.

Steam or hot water unit heaters. Steam or hot water unit heaters are chiefly used to heat large, unpartitioned areas or commercial structures, such as garages, shops,

laboratories, stores, base exchanges, and mess halls.

Electric unit heaters. These heaters are used principally for supplemental heat in housing, sentry booths, small offices, locker rooms, and isolated rooms scattered over wide areas.

Gas-fired unit heaters. Gas-fired unit heaters can be used in almost every location where steam or hot water unit heaters are used.

Oil-fired unit heaters. Oil-fired unit heaters can be used in commercial buildings, industrial plants, shops, and garages.

Location of Unit Heaters. The height at which the unit is mounted affects the air temperature distribution and heater coverage. Proper mounting heights vary with unit designs. However, as a rule, the higher the location, the lower the blow into the occupied zone. With very high locations, it may be necessary to lower the outlet air temperature to force the air into the desired space. Figure 1-23 illustrates the location usually recommended; however, specific recommendations should be obtained from the manufacturer of the individual equipment. Locate unit heaters so that they discharge heated air nearly parallel to exterior walls, in a direction that will produce a rotational circulation around the room. Assure that the air circulates freely to the heater intake.

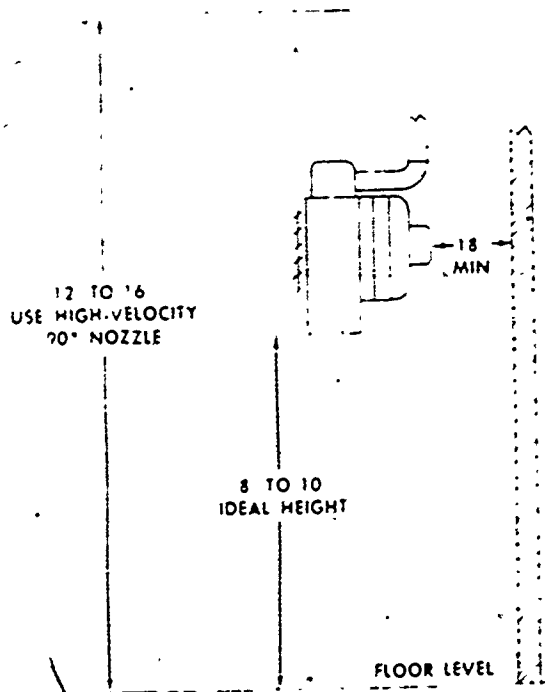


Figure 1-23. Unit heater location.

Exercises (409):

- 1. Cite the factors that are considered when selecting a unit heater for a certain application.
- 2. Specify the locations where a steam or hot water unit heater may be installed.
- 3. Specify the installation locations for electric, gas-fired and oil-fired unit heaters.

1-4. Fundamentals of Heat Exchangers

Heat exchangers are equipment that uses heat-conveying media (hot water, steam, warm air) to heat a room. Such equipment is designed and installed to maintain the desired

mean ambient temperature in the areas. Since heat losses through various parts of a structure may differ, heat distributing units should be located and regulated to assure that their heat output compensates for the losses where and when they take place. In other words, if 60 percent of a room's total heat loss is through a window area, 60 percent of the total heat input should be at that area.

410. Name the types of heat exchangers and state the operating principles for radiators, convectors, finned tube units, and electric ceiling panels.

- (1) Radiators.
- (2) Convectors.
- (3) Baseboard Units.
- (4) Finned-Tube Units.
- (5) Panel Heating.

Radiators. The term "radiator" is usually applied to heat exchange units, hollow cast-iron sections, joined by nipples. Three types of radiators are now manufactured: column, small-tube, and wall. In the past a large-tube radiator was manufactured, but it has been replaced by the small-tube (with a spacing of 1 3/4-in per section) that occupies less space and can be recessed. Radiators are heated by conduction through contact with steam or hot water. They then transfer the heat to rooms or areas by radiation and convection. Usually units that have large, exposed heating surfaces emit more radiation heat than those with concealed surfaces. The total amount of heat transferred from the radiator to the surrounding area depends on the heating surface area, the average surface temperature of the unit, the nature and finish of the surface, unit configuration, ambient room temperature, and location of the unit. Locate radiators where the heat loss is greatest, i.e., beneath the windows of a room. If a radiator is placed along an inside wall, cold infiltrated air (which is heavier than warm air) will cross the room near the floor and chill the occupants. But if the radiator is located properly, the infiltrating air will be warmed by the radiator and will rise, cross the ceiling, and go down the opposite wall before it contacts the room occupants.

Pipe coils. In industrial buildings, radiators made of pipe coils are often used. They are usually located under windows or where high rates of heat loss occur. The pipe normally has a diameter of 1, 1 1/4, or 1 1/2 inches. The coils are usually assembled in rows of

horizontal pipes and placed vertically on a wall. Steam is the most frequently used heating medium.

Convectors. A convector is a heat-exchange unit that operates by the convection principle. A convector consists of a heating element within an enclosure. Air enters the enclosure through an opening below the heating element and is discharged at another opening above the heating element. Since the convection principle is used, no mechanical device is required to recirculate the room air through the unit. Cold air enters the convector below the heating element, is heated by contact, and convected upward through the outlet opening of the enclosure. The types and design of enclosures vary with requirements. Outlet air openings are usually grilled; inlet openings can be either open or grilled. Convectors may be free-standing, wall-hung, or recessed. The heating medium can be hot water, steam, or electricity.

Electrical convectors. Many installations use electrical convectors because their heat output is flexible, and such convectors are designed to save space, and are easy to install. There are many different designs and several types of electric heating elements. In a typical design, the enclosure is a heavy-gage metal cabinet with easy air access at the bottom, the heating element is a bank of metal-sheathed strip heaters.

Baseboard Units. Baseboard radiation consists of long low-heating units, generally installed along the bottom of outside walls, that resemble and replace conventional baseboard. They operate by the convection principle, although in most cases a substantial portion of their total heat output is transferred by direct radiation to cooler surfaces. Baseboard units are suitable for use on hot water and steam heating systems. Electric baseboard units are also available. The main advantages of baseboard units are:

- (1) Ease of installation along cold wall and under areas where rate of heat loss is greatest.
- (2) Heat distribution near the floor, and consequently a more uniform temperature from floor to ceiling.
- (3) Practically no interference with furniture.
- (4) Ease of concealment.
- (5) Convenience of installation (to prevent cold floors) in houses with basements.
- (6) Perimeter heating, and even wall-to-wall temperatures.

246

Types of Baseboard Units. Baseboard units may be of three basic types: radiant, radiant-convactor, and finned-tube.

Radiant-type units are usually constructed of hollow cast-iron or steel sections. When no space is available for floor or wall mounting, they are suspended from ceilings. However, suspended units transfer less heat by convection than floor or wall units.

Radiant-convactor units have enclosures with air inlets at the bottom and air outlets at the top. In some designs, the openings have grills or dampers to regulate the airflow. The heating elements consist of hollow cast-iron or steel sections. A large percentage of the total heat output of these units is transmitted by convection. Although the temperature of all baseboard units is kept rather low, these units can yield a higher heat output per linear foot than the radiant type. They are, therefore, particularly suitable for installations with high heat loss or scarce wall space.

The heating elements of finned-tube baseboard units consist of tubes into which light weight fins are mechanically bonded or embedded to increase the heating surface. The tubes may be ferrous or nonferrous (usually steel or copper) with fins of steel or aluminum. The units come in standard lengths for ease of installation. The heating elements are concealed by enclosures of several designs, and a considerable percentage of the total heat output is emitted by convection. The heat output per linear foot varies with the different designs, sizes, and materials used. In general, baseboard installations are designed for the minimum output per linear foot compatible with the total heat losses. Units are usually installed along as much of the exposed wall as possible. When desired, dummy sections without heating elements can be used to provide continuity in the installation and simulate a conventional baseboard.

Finned Tube Units. When maximum convected heat per lineal foot is required, finned tube units are normally used. They consist of finned-tube elements fabricated by bonding metallic fins to metallic tubes. The tubes and fins can be all steel, or copper (tubes) and aluminum (fins). Generally, these units are placed along the walls, where the heat loss is greatest; if necessary, they can be installed in two or three tiers. The heating medium is either steam or hot water. When hot water is used in a multiple tier installation, a continuous water flow through

a coil-type arrangement is preferred. If a grid installation, with header connections for parallel flow, is used, water may short-circuit through the path of least resistance and reduce the heat output. These units can be equipped with various types of covers, enclosures, or protective grilles. However, they are often installed without covers, and with the elements supported from walls or ceiling by suitable hangers. The heating output of finned tubes depends on operating conditions, heating surface, and fin design construction materials, and surface finish. In most cases, a substantial percentage of the heat is transferred by convection.

Panel Heating. In panel heating, large zones of interior room surfaces are heated to relatively low temperatures—80° to 125° F. Heat is transferred by radiation and convection from the panels to the air and surrounding surfaces. The percentage of radiation and convection heat output varies, primarily with location of the heated panels. More than 90 percent of the total heat output from ceiling panels is transferred by radiation, the balance, by convection. The radiation heat output is less from wall panels, and even less from floor panels, because the ambient air, warmed by conduction through the heated surfaces (wall or floor), sets up convection currents. This effect is relatively unimportant in ceiling panels because normally a thin blanket of heated air lies against the ceiling, and most of the heating below is by radiation. Heat emission from heating panels is usually expressed in Btu per square foot of surface per hour. Emissions vary according to panel surface temperature, ambient air temperature, and average surface temperature of unheated surfaces. The greater the temperature difference between panel surface and ambient air, and between panel surface and unheated surfaces, the greater the heat release from the panel.

Heating Methods. The following heating methods are used in panel heating:

Low-temperature hot-water heating. Low-temperature hot water is the most frequently used heating medium. Heating is supplied by circulating the hot water through embedded piping and tubing.

Warm-air heating. Air ducts placed under the floor, in side walls, or ceilings are used when specific local factors are favorable.

Electric heating. Electric panel heating, using embedded electrical heating elements, has come into favor for a number of applications. The ceiling panel and the wall panel are the main types used.

Steam heating. Because of its higher temperature, steam is used only occasionally in panel heating.

Panel Heating Types. The following listed systems are the common methods employed for-panel heating:

Ceiling panel. For hot-water heating systems, piping or tubing is embedded in ceilings. In concrete-slab ceilings, the piping or tubing is embedded in the lower part of the slab, close to its lower surface. In other installations, pipe or tubing is embedded in a metal lath and plaster ceiling. The lath is in contact with the piping; the plaster is applied to the lath. For warm air systems, channels or ducts are built into the panel sections through which the warm air circulates.

Wall panel. Designs similar to those described for ceiling panels are sometimes used for wall panels.

Floor panel. For hot-water systems, the piping is completely embedded in the floors, and does not rest on an interface. Reinforcing steel rods, pieces of pipe, or stone concrete mounds are generally used to support and position the piping. No absorbent or organic material, such as wood, should be used for this purpose. In warm-air systems the warm air is circulated through ducts in passages under the floors.

Electric ceiling panel. One common design of electric, ceiling-panel heating uses especially designed cables about 1/8 inch outside diameter, embedded in plastered ceilings. The resistor cables are electrically insulated with a special compound that resists high temperature, water absorption, aging effects, and chemical action with plaster, cement, and soil. Cable units come in lengths of 80-ft (loop), 160-ft (loop), 960-ft (on reel) and 5,000-ft (on reel) with 10-ft, nonheated lengths attached to each unit. Capacities vary with the heated length of the unit, being 400 watts at 120 volts for the 80-ft loop, and 800 watts at 240 volts for the 160-ft loop. The cable units are stapled to the ceiling lath and covered with plaster. The maximum safe operating temperature is about 165° F., and the test voltage is 2,500 volts. Heating effect is principally by radiant heat, since normally a thin blanket of heated air lies against the ceiling and the only heating below is by radiation.

Electric wall panel. Occasionally, electric panel installations similar to those described for ceiling are embedded in walls. However, most codes prohibit such panels because nails driven into the walls, or building alterations, may cause considerable damage.

Exercises (410):

1. Name the types of heat exchangers and include the subclassification, if any, for each type.
2. State the operating principle for the following:
 - a. Radiators.
 - b. Convectors.
 - c. Finned tube units.
 - d. Electric ceiling panel.

411. From a given list of maintenance requirements, check those that pertain to heat exchangers.

All heat exchangers, regardless of type or heat media, are inspected on a monthly basis plus a complete summer inspection and a preseason check.

Start of Heating Season. Check operation of all valves and regulators, and condition of steam traps and air vents.

Monthly. The following information pertains to the monthly preventive maintenance inspections for the various types of heat exchange equipment used for space heaters.

Radiators. Check operation of radiators. Make sure there is no obstruction to free flow of the steam, condensate, and water. On steam radiators, see that steam completely fills the unit, without hot spots or uneven temperatures. Be sure that the condensate is removed rapidly. Check operation of traps to assure that only condensate and air are allowed to pass and steam is not blowing through. On all radiators, check radiator valves and regulators for proper operation. Check operation of vents and inspect for leaks.

Convectors. Follow procedures outlined above for radiators. In addition, make sure

there is no undue obstruction to free flow of convection air. Check conditions of enclosure, grilles, baffles, and dampers, in convector cabinets.

Baseboard units. Follow procedures described for convectors.

Pipe coils. Follow procedures described for radiators.

Summer Inspections. At the end of the heating season, carefully repeat the monthly inspection outlined above. Look for corrosion, erosion, clogging, scaling, cracking, or evidence of abnormal temperatures and pressures on the heating elements. Make all necessary repairs or replacements indicated by these inspections.

Exercise (411):

From the following list of maintenance actions, indicate the requirements for heat

exchanger maintenance by placing an "X" in the blank provided if the statement given is a requirement.

- 1. Check for free flow of steam.
- 2. Make sure condensate does not flow and cause erratic circulation.
- 3. Check operation of traps.
- 4. Check valves and regulators for proper operation.
- 5. Check to see that free flow of convection air is obstructed.
- 6. Make sure there is no obstruction to convection air.
- 7. Look for corrosion, cracking, and spalling.
- 8. Look for scaling, erosion, cracking, clogging, or corrosion.
- 9. Perform necessary maintenance dictated by inspections.

CHAPTER 2

Burners

IN THIS CHAPTER we will discuss oil burners and gas burners. You may be called upon to help install, operate, or maintain any of these various types of equipment. By gaining the knowledge in this chapter, you will be able to understand the construction, operation, and maintenance of the many types of equipment you will be called upon to work with.

2-1. Types of Oil Burners

Fuel oil has been described as a mixture of hydrocarbons in a liquid state. But fuel oil will not burn as a liquid, only as a gaseous hydrocarbon. An oil burner must convert the liquid fuel to a gaseous state and provide a thorough mixing of the gaseous fuel and the air required for combustion.

The conversion of a liquid fuel to a gaseous state is called vaporization. With the lighter oils, vaporization can be obtained by the direct application of heat to a pool of the liquid. This is generally restricted to small domestic services. Burners for this purpose are usually of the pot type with natural or forced draft, gravity float feed control, and hand or electric ignition.

In other burners, the liquid is atomized by the nozzle, and then gasified by reflected heat from the combustion chamber. Oil burners have been designed to burn all grades of distillate and residual oil.

412. Name the types of oil burners, state a main difference between domestic and industrial oil burners, and match the oil type with the method of fuel atomization or vaporization.

Oil burners are classified into the following main categories: domestic and industrial.

Domestic Oil Burners. Domestic oil burners vaporize or atomize the oil and deliver a predetermined quantity of oil and air to the

combustion chamber. They operate automatically and maintain a desired rate of combustion. A classification generally recognized by the oil burner industry is based on design and construction. The three types of domestic oil burners that we will cover are the gun-type high-pressure oil burners, gun-type low-pressure oil burners, and vertical rotary oil burners.

Gun-type high-pressure burners. The high-pressure gun-type oil burner is the most popular type. Its simple construction makes necessary only two operating adjustments. The high-pressure burner, shown in figure 2-1, is a carefully designed and precision-built oil burner constructed for durability and long service. The high-pressure burner consists of motor, fan, ignition transformer, fuel unit, nozzle, electrode assembly, and the casing to which all of these parts are attached. The parts of a high-pressure gun-type oil burner are usually interchangeable with other burners of this type. Oil is pumped under high pressure (80-140 psi) through nozzle. The oil is atomized as it is sprayed from the nozzle orifice.

Gun-type low-pressure burners. The low-pressure gun-type oil burner is different from the high-pressure gun-type burner. The parts of a gun-type low-pressure burner are also different from the parts of other burners of this type. It is necessary, therefore, to study each type individually. Figure 2-2 illustrates a typical low-pressure gun-type burner. This is a backside view of the burner and shows the location of the compressor, oil strainer housing, oil sump, and various adjustments.

Figure 2-3 shows the oil and air being brought together inside a compressor and mixed. This mixture is delivered into a separating chamber called a sump, where it is separated. Then the oil and air are again brought together in an air friction-type nozzle and remixed. This basic cycle provides

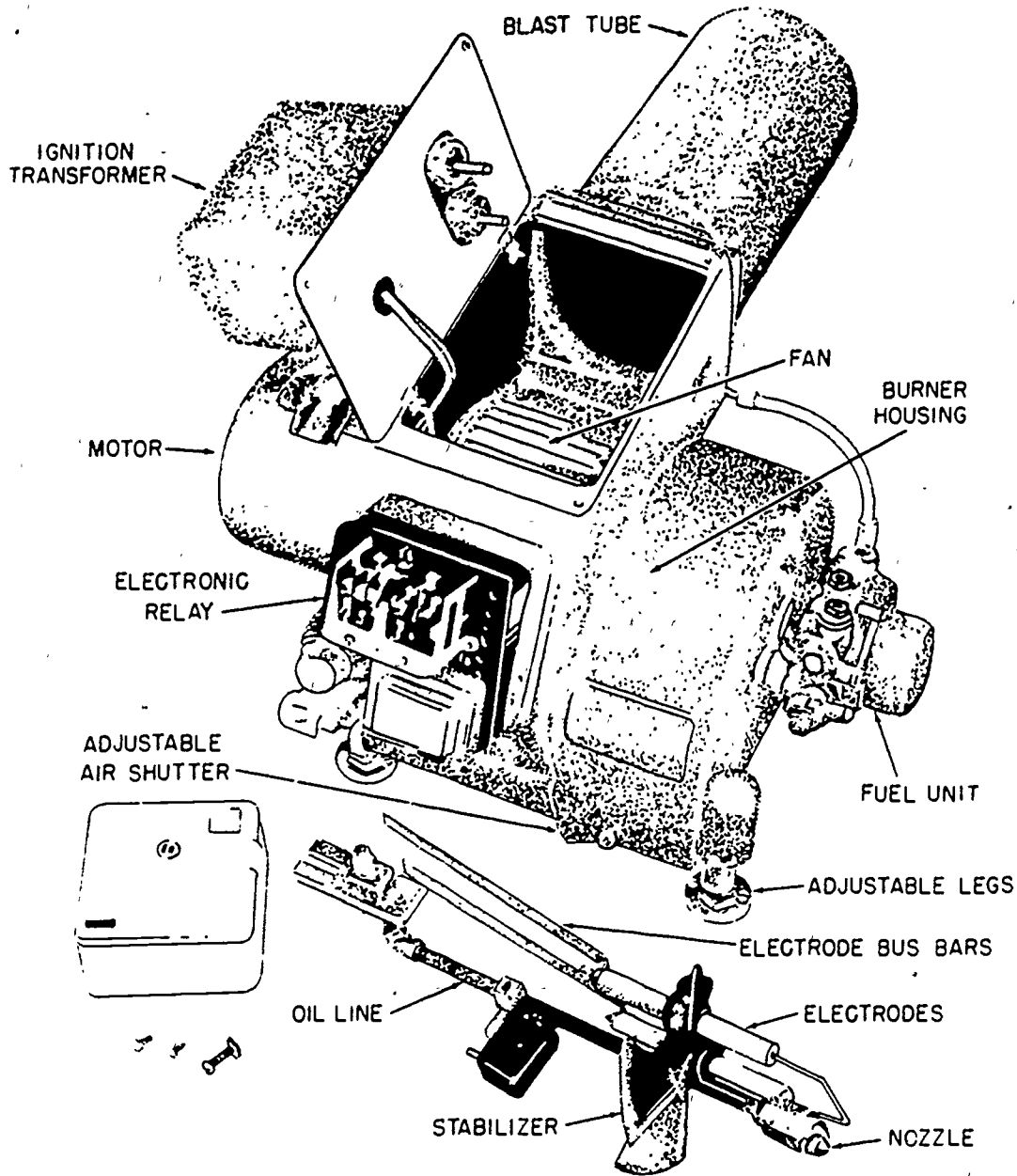


Figure 2-1. High-pressure gun-type oil burner.

smooth oil travel and uninterrupted delivery. The three indispensable parts of the gun-type low-pressure burner are the rotary compressor that pumps the oil and air, the sump or separating chamber, and the nozzle. (The nozzle of the low-pressure burner is very different from the nozzle of the high-pressure burner.) This type of nozzle is illustrated in figure 2-4.

The air used for atomization of the oil is only a small portion of the air required for proper combustion. Consequently, a

motor-driven blower, with the means of throttling the air supply, provides additional air. The oil-flow rate is controlled by adjusting the air atomizing pressure.

Vertical rotary burners. There are two distinct types of vertical rotary burners—the atomizing or radiant-flame burner and the vaporizing or wall-flame burner. The atomizing burner, sometimes called the suspended-flame burner, atomizes the oil by throwing it from the circumference of a rapidly rotating motor-driven cup. The

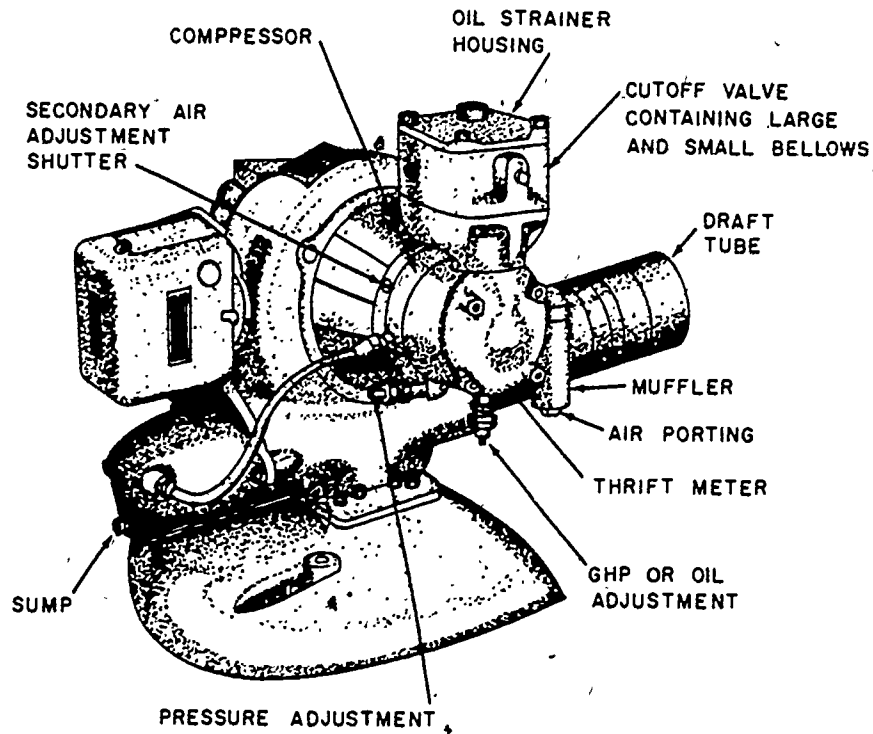


Figure 2-2. Low-pressure gun-type oil burner.

radiant-flame burner is shown in figure 2-5. The burner must be installed so that the driving parts are protected from the heat of the flame by a hearth or refractory material at about grate level. The oil may be fed by a pump or by gravity, while the draft may be either forced or a combination of natural draft and forced draft. The air-oil mixture

burns as a suspended flame without striking the furnace walls.

The vaporizing or wall-flame burner, also called the blue-flame burner, has an oil distributor and fan blades mounted on a vertical shaft that is directly connected to a motor. A refractory hearth shields the motor from the flame. The oil distributor projects

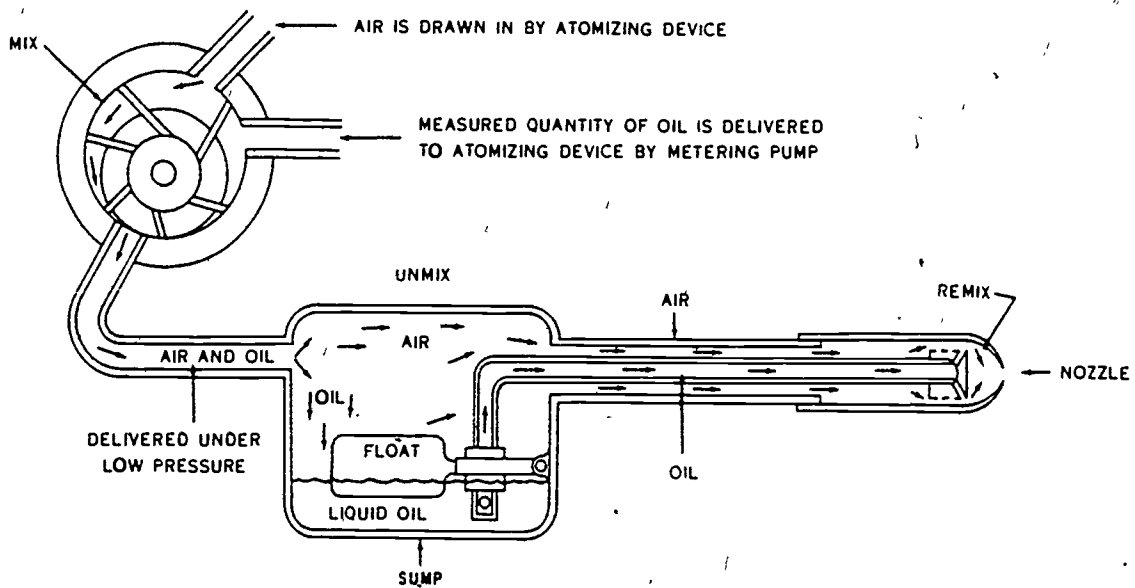


Figure 2-3. A schematic diagram of air atomization employed by a low-pressure gun-type burner.

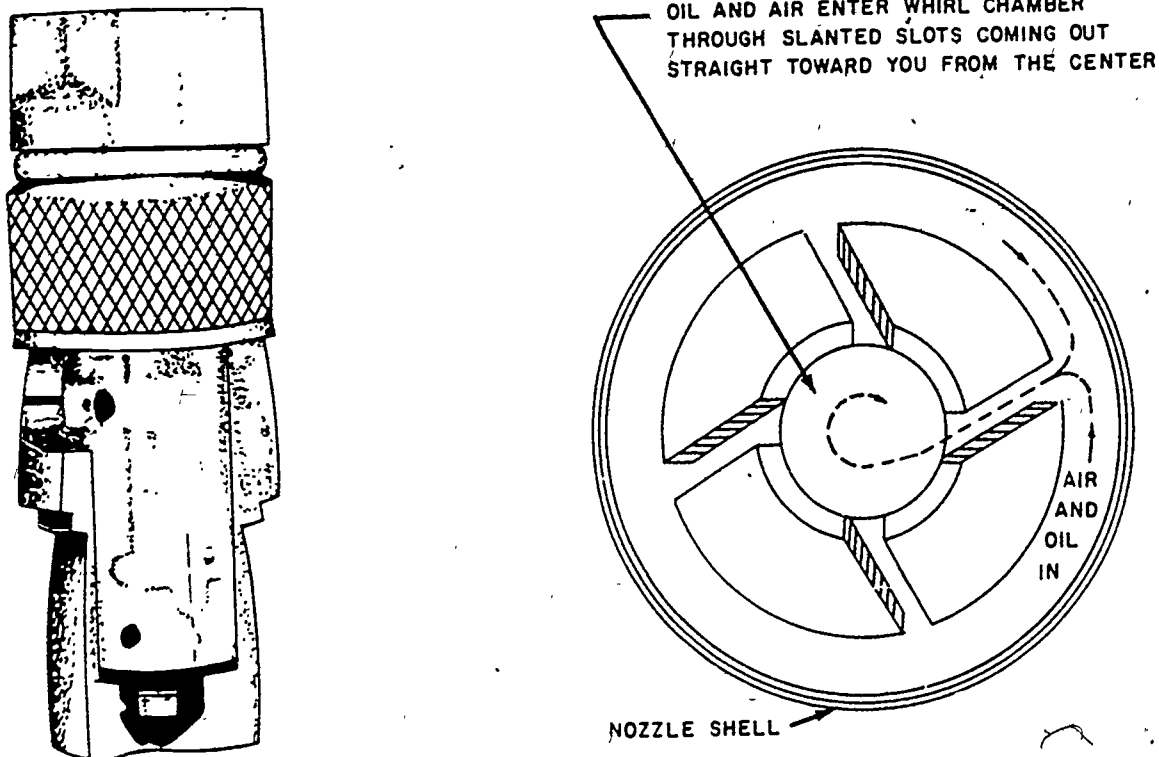


Figure 2-4 Low-pressure nozzle and a cutaway view of the nozzle.

the oil to a flame ring, which may be either refractory material or metal. The flame ring of the wall-flame burner is shown in figure 2-6. The hot flame ring vaporizes the oil; and the oil vapor mixes with air and burns with a quiet, blue flame that sweeps the walls of the

furnace. Wall-flame burners can use electric, gas-electric, or gas ignition devices. Satisfactory performance in small furnaces requires the use of high-grade furnace oil.

Industrial Oil Burners. There are many types of industrial oil burners. Some of them

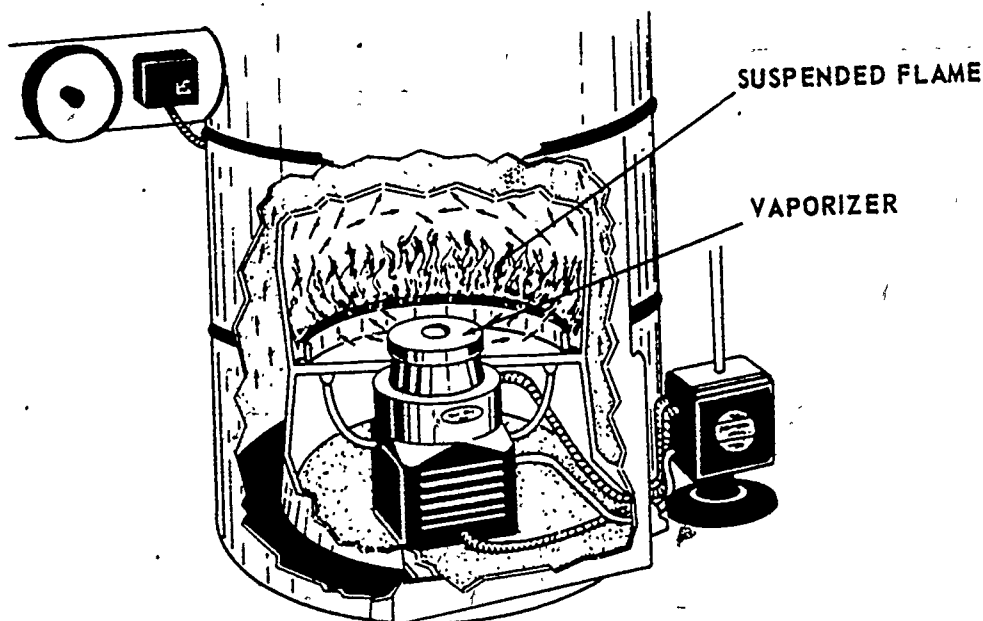


Figure 2-5. Cutaway view of a radiant-flame burner.

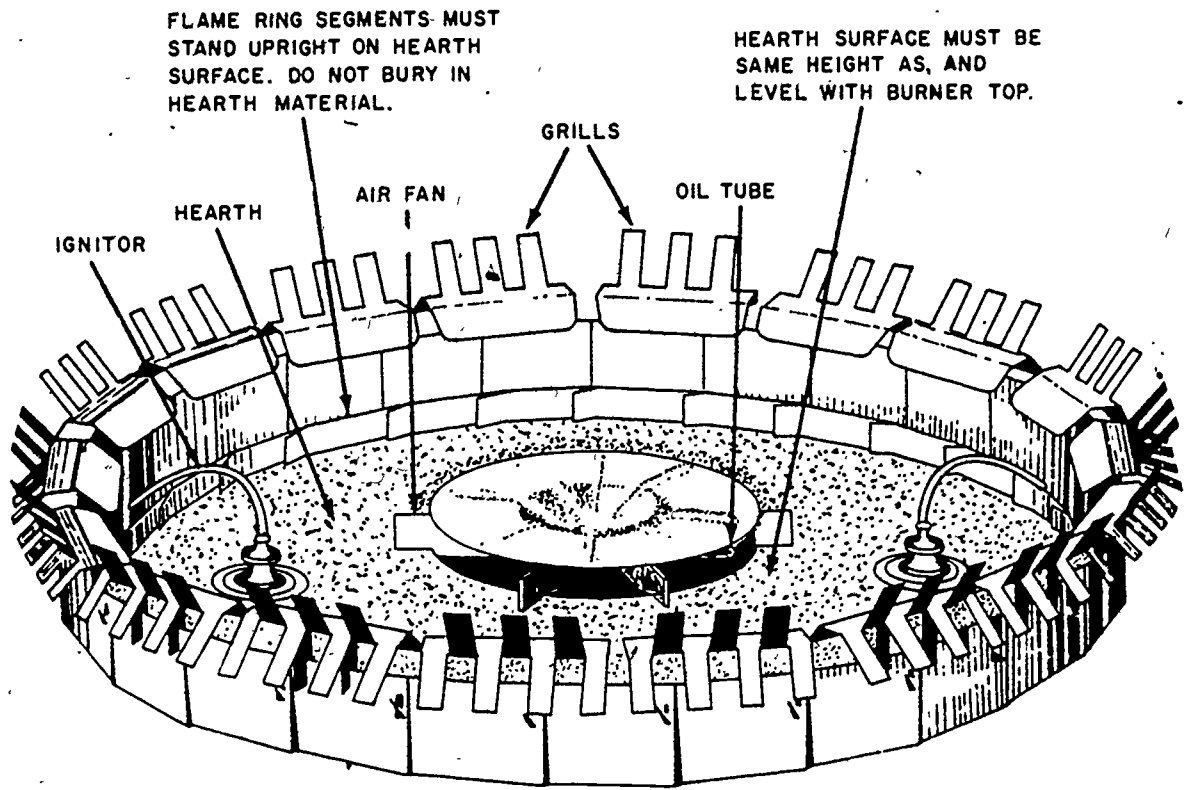


Figure 2-6. Top view of a wall-flame burner flame ring.

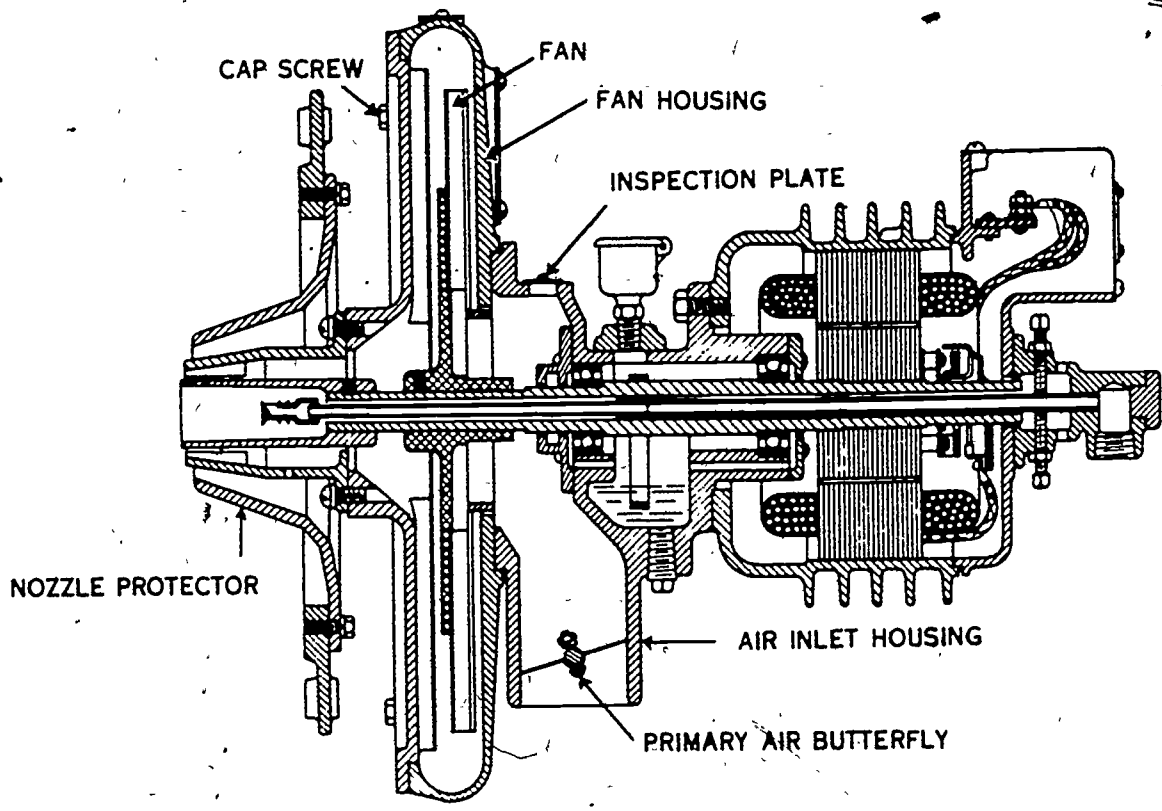


Figure 2-7. Horizontal rotary cup burner.

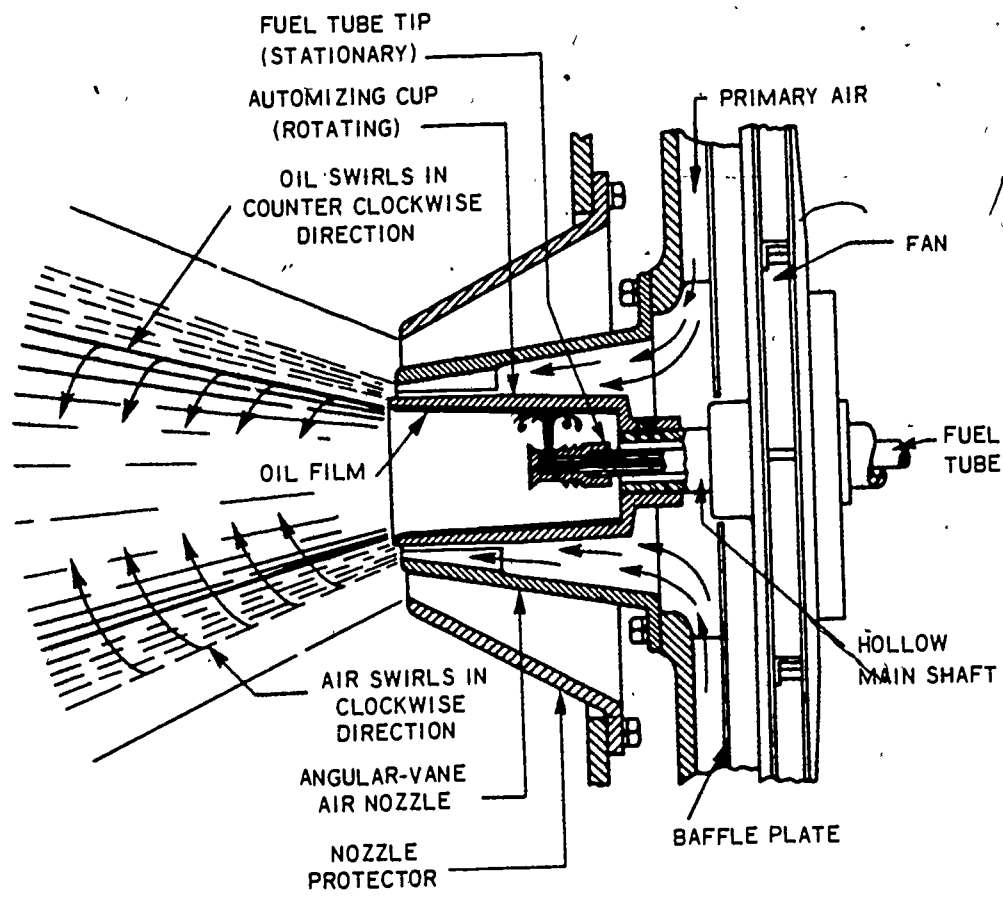


Figure 2-8. Horizontal rotary burner.

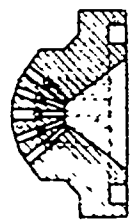
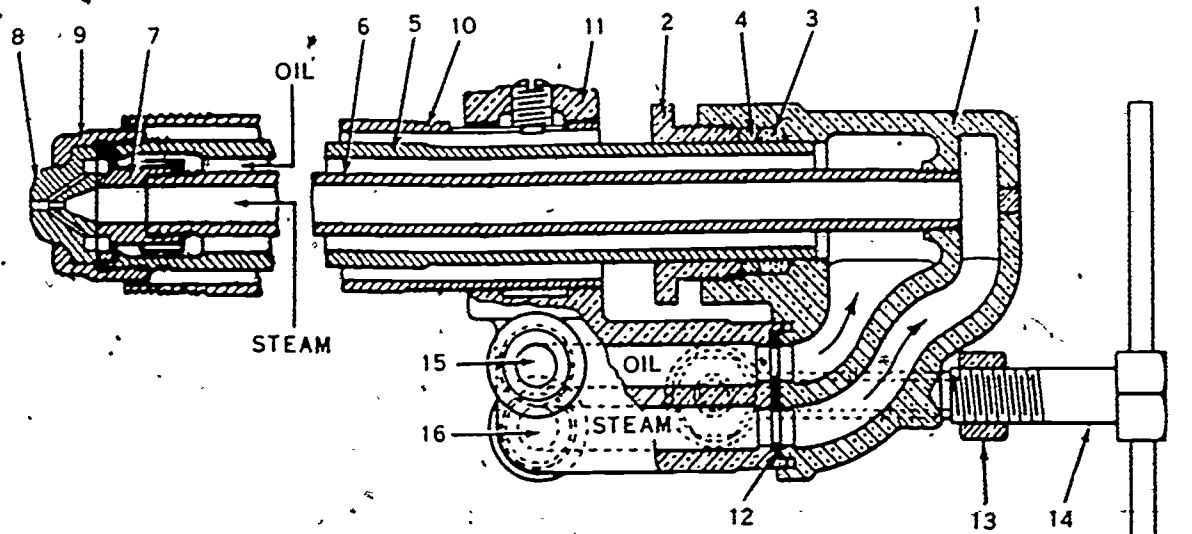
are enlarged units of the domestic type. Some small industrial models, with slight modifications, can be used in domestic as well as industrial heating systems.

Oil burners and equipment for industrial use are usually designed to burn lower cost, heavy fuel oils such as US Commercial Standard Grades No. 4, No. 5, and No. 6. The viscosities of these oils are much greater than those of the lighter domestic grades. For this reason the equipment required for satisfactory storage, pumping, and combustion differs considerably from that used in most domestic oil-burning systems. The most common industrial oil burners are horizontal rotary burners, atomizing burners, and mechanical burners.

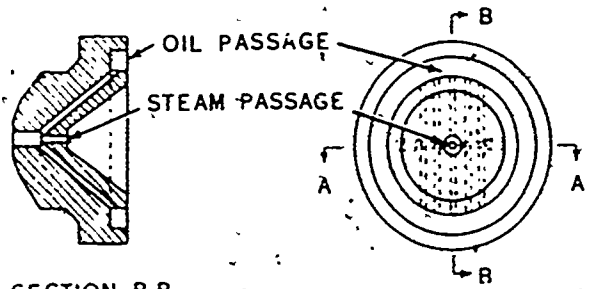
Horizontal rotary burners. The horizontal rotary burner, illustrated in figure 2-7 and 2-8, atomizes fuel oil by breaking it into tiny droplets. The air is admitted to the burner (fig. 2-7) through the primary air butterfly to the fan which is rotated by an electric motor. The air leaves the burner nozzle at a high velocity in a clockwise direction (fig. 2-8).

The fuel oil flowing from the fuel tube tip is atomized by a rotating atomizing cup which ejects the fuel against the air stream in a counterclockwise direction. Notice that the fuel tube extends through the center of the motor and fan shaft. The heat output of the burner is regulated by changing the oil pressure supply to the burner. Primary air (supplied by the integral fan) is controlled by a damper in the suction side (see fig. 2-7). Secondary air can be supplied through openings in the floor directly below the burner or through passages in the wall around the burner. The shape of the flame is determined by the angular-vane nozzle through which the air is discharged. This burner is commonly used for both domestic and industrial operation.

Atomizing burners. Atomizing burners can use air or steam as the atomizing medium. They consist of a properly formed jet-mixing nozzle to which oil and steam or air are piped. The atomizing medium, mixes with fine particles of fuel passing through the nozzle, and the mixture is projected into the furnace. Nozzles may be of the internal (inside) mixing



SECTION A-A



SECTION B-B

SPRAYER PLATE PART 8

- | | | | |
|---|---------------|----|---------------------------------|
| 1 | ATOMIZER BODY | 10 | DISTANCE PIECE
IMPELLER PIPE |
| 2 | GLAND | 11 | COUPLING |
| 3 | PACKING | 12 | GASKET |
| 4 | FOLLOWER RING | 13 | COUPLING YOKE |
| 5 | BARREL | 14 | YOKE SCREW |
| 6 | INTERNAL TUBE | 15 | OIL CONNECTION |
| 7 | SPRAYER HEAD | 16 | STEAM CONNECTION |
| 8 | SPRAYER PLATE | | |
| 9 | END CAP | | |

Figure 2-9 Fuel oil steam atomizing burner.

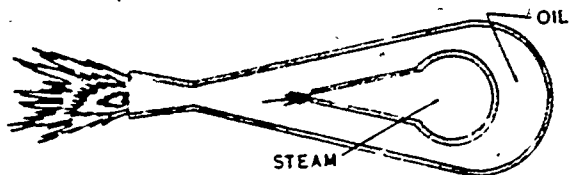


Figure 2-10 Cross-section of an inside-mix oil burner nozzle

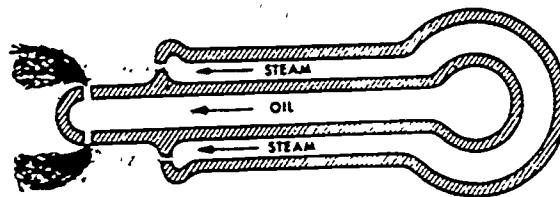


Figure 2-11. Cross-section of an outside-mix oil burner nozzle.

type or the external (outside) mixing type. In the first type, the oil and steam or air are mixed inside the burner; in the second type, they are mixed at the burner orifice exit. Since steam atomizing burners are less expensive than the air atomizing types, they are most commonly used. They handle commercial oil grades number 4, 5, and 6 and require a steam pressure varying from 50 to 125 psig. When the burner is operating, it maintains a pressure differential between the steam and oil pressure of about 20 to 25 psig.

The heat output of the burner for a given burner tip (sprayer plate) is changed by varying the oil pressure up to the maximum allowed. Higher capacities can be obtained by changing the burner tips. Combustion air enters through a register where adjustable vanes help control the shape of the flame. An impeller plate attached to the furnace end of the burner imparts a swirling motion to the air to promote combustion and mixing. Figure 2-9 illustrates a fuel oil, steam

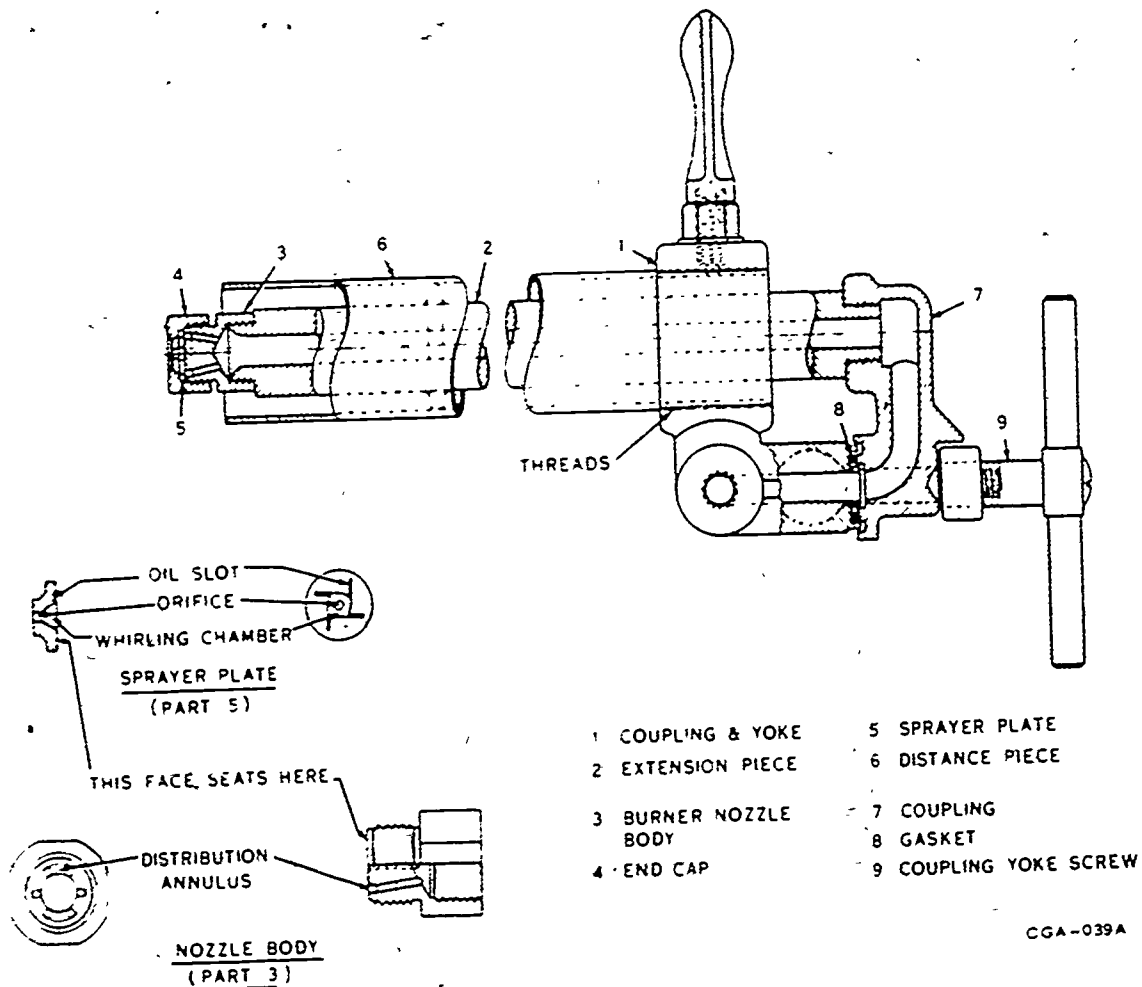


Figure 2-12. Fuel oil mechanical burner.

atomizing burner. The figure shows a longitudinal section of the burner and detailed sections of the burner tip (sprayer plate).

a. Inside-mix type. The inside-mix oil burner normally produces a flat or conical flame, depending upon the type of nozzle used. For an oil burner subjected to wide fluctuations or extreme loads, a nozzle similar to the one in figure 2-10 is used.

b. Outside-mix type. A burner of the outside-mix type uses a nozzle similar to the one illustrated in figure 2-11. Air for combustion is produced by natural draft. The units equipped with this type of burner will operate at a high rate of efficiency only when limited to moderate capacities without high fluctuations. It is not adapted to fully automatic operation or to wide variations in firing rate. This burner is relatively low in initial cost.

Mechanical burner. Mechanical burners use oil pressure and specially designed nozzles to atomize the fuel. Atomization results when oil under high pressure (100-225 psig) passes through a small orifice and emerges as a conical mist. The orifice that atomizes the fuel is often aided by a slotted disk that whirls the oil before it enters the nozzle. Air for combustion is supplied in a manner similar to that used for steam atomizing oil burners.

Head output is also varied as in steam atomizers: Figure 2-12 illustrates a longitudinal section of a mechanical atomizing burner and detailed sections of the nozzle body and sprayer plate.

Exercises (412):

1. Name the types of domestic oil burners.

2. Name the types of industrial oil burners.

3. Match the type of oil burner in column A to the method of oil vaporization or atomization by writing the correct letter(s) in the blank provided. Column B items may be used once, more than once, or not at all.

- | | |
|--|--|
| Column A | Column B |
| 1. <input type="checkbox"/> Vertical rotary burners. | a. Fuel oil is atomized by breaking it into tiny droplets. |
| 2. <input type="checkbox"/> Horizontal rotary burners. | b. The oil is vaporized by the hot flame ring. |

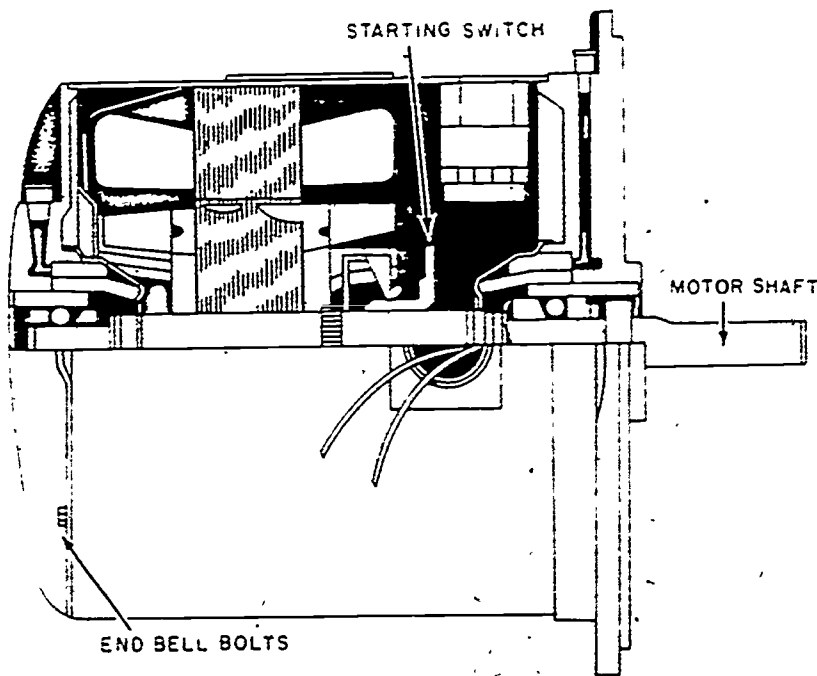


Figure 2-13. Cutaway-view of an electric motor.

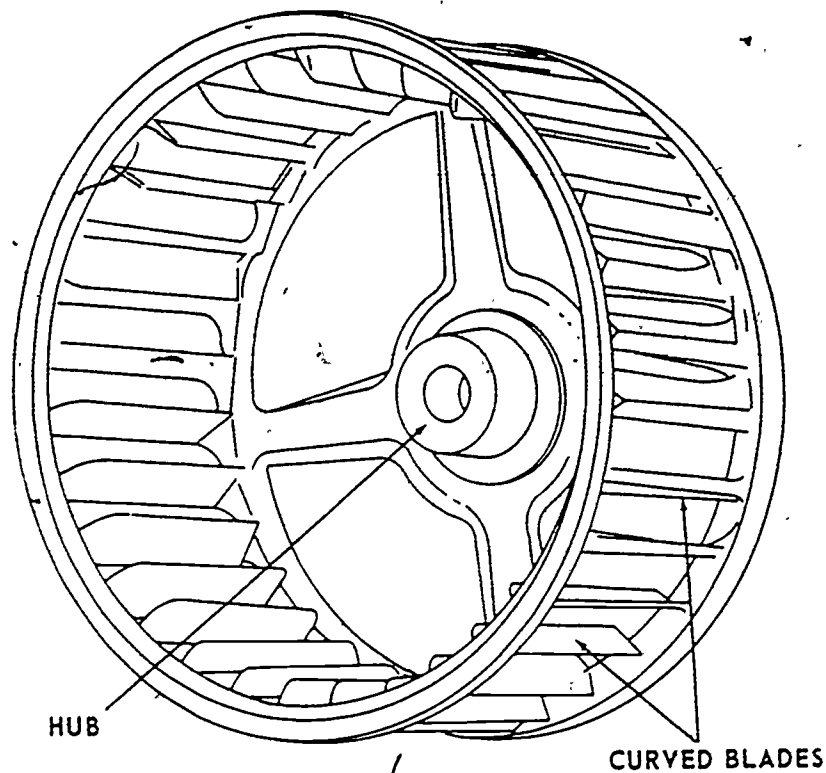


Figure 2-14. A multiblade fan.

Column A

- 3. Industrial atomizing burners.
- 4. Mechanical burners
- 5. Gun-type high-pressure burner.
- 6. Gun-type low-pressure burner.

Column B

- c. Steam combines with fine particles of oil to atomize as it passes through the nozzle.
- d. Oil is atomized by throwing it from a rapidly rotating motor driven cup.
- e. Oil pressure and specially designed nozzles atomize the oil.
- f. By a specially designed air-friction type nozzle.

an integral part of the burner. It is mounted on the burner by means of a two-, three-, or four-bolt flange. Remove these bolts in order to repair or replace the motor. If it has oil cups, the motor should be oiled about twice a year. Special attention should be given to oiling the motor, because overoiling it can cause damage. A starting switch opens the circuit to the starting windings by centrifugal force as the motor reaches its rated rpm.

Another motor of the same rotation, mounting, and revolutions per minute (rpm) is generally used as a replacement in the event of motor failure. Basically, however, all oil burner motors are similar; consequently, replacement motors do not always have to come from the same manufacturer. The important factors are the direction of rotation, rpm, and mounting.

Fan. A fan or blower partially shown in figure 2-1, is better illustrated in figure 2-14. The unit, located in the burner fan housing, is driven directly from the motor shaft, this fan provides the necessary air to support combustion. The fan wheel is of multiblade design capable of furnishing enough air to the draft tube. The volume of air handled by the fan is readily controlled by an adjustable air shutter (on the housing) that controls the air intake to the burner.

413. From given statements, select those that identify components of a gun-type high-pressure oil burner.

The components of a gun-type high-pressure oil burner were listed in the text of Learning Objective 412. However, we will cover them in more detail in this learning objective.

Motor. An electric motor, like that shown in figure 2-13, drives the fan and the fuel pump. The motor is specially designed and is

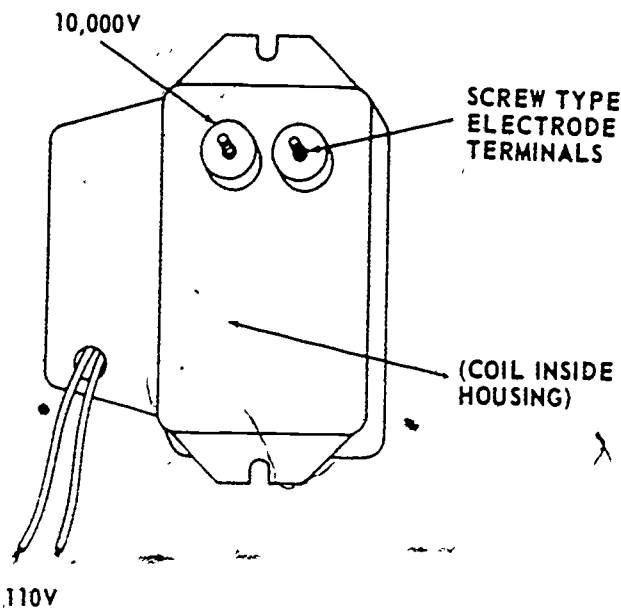


Figure 2-15. An ignition transformer.

Ignition Transformer. The ignition transformer, like that shown in figure 2-15, is usually located at one side or on top of the burner, and it provides the "step-up" from the line voltage of 110 or 125 volts to the 10,000 volts required for ignition. The spark jumping across the gap between the electrodes provides heat that ignites the oil spraying from the nozzle. When replacing a burned-out transformer, be sure to replace it with one of the proper type and with identical mounting holes.

Fuel Unit. The fuel units of a high-pressure gun-type burner may be either single- or two-stage units using one- or two-pipe supply systems. Each of these units has a specific application; therefore, one unit must never be applied to the use for which the other is intended.

Single-stage fuel units. The single-stage fuel unit illustrated in figure 2-16 has one pumping stage that takes the oil, fed by gravity, and applies sufficient pressure to force the fuel through the nozzle. The single-stage unit is, therefore, best adapted where an elevated tank is used and the oil is fed by gravity to the burner. As indicated by the arrows, the fuel enters the suction port

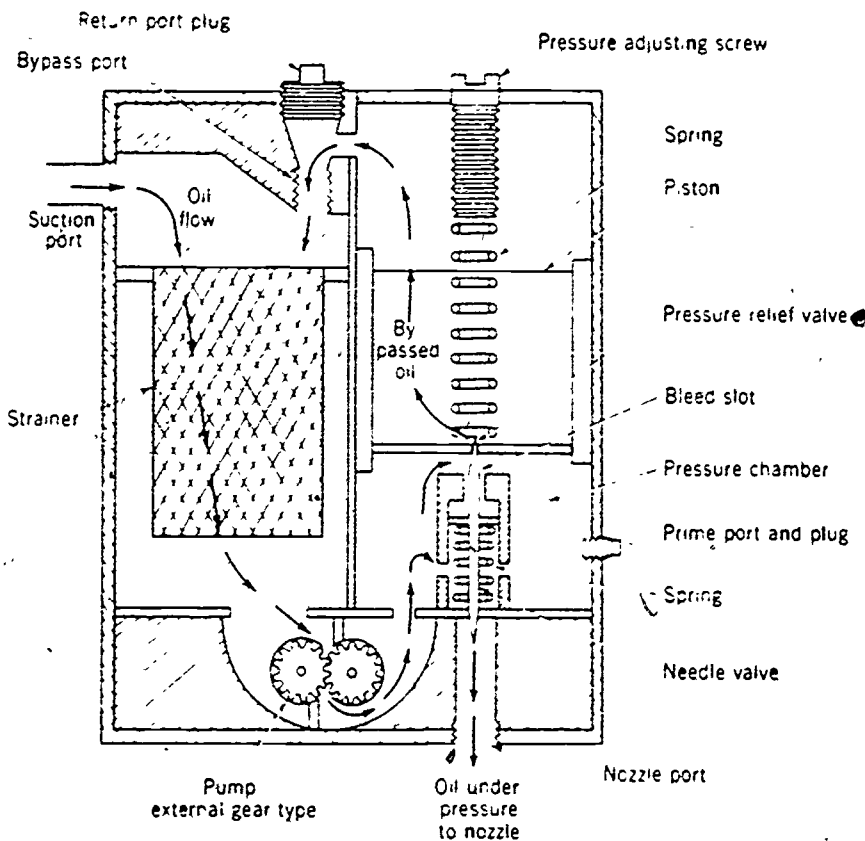


Figure 2-16. A single-stage fuel unit.

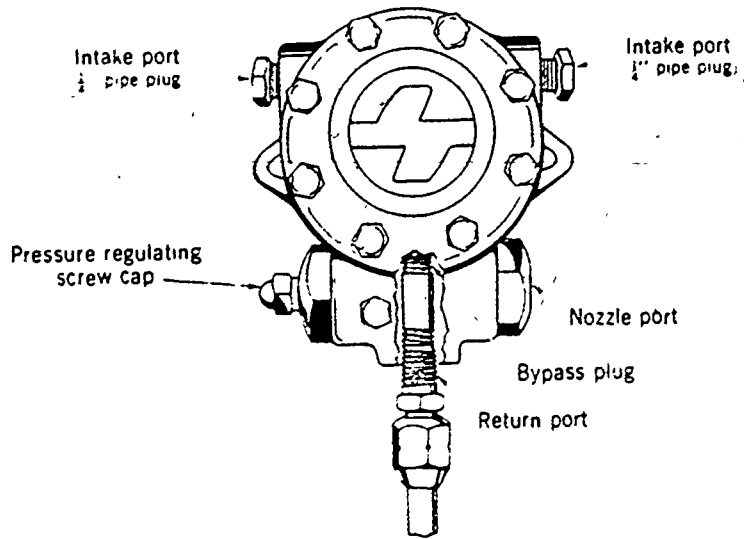


Figure 2-17. A two-stage fuel unit.

and passes through the strainer to the external gear type pump. The pump applies the fuel oil under pressure to the pressure chamber. The pressure oil applied to the bottom side of the needle valve piston unseats the needle valve permitting oil to discharge at the nozzle port. When the oil pressure against the bottom of the large piston exceeds the pressure determined by the pressure adjusting screw and spring acting against the upper side of the piston, the piston rises and unseats the upper end of the needle valve in the piston. This permits the excess oil to bypass through the piston, through the bypass port and to the suction side of the strainer. As the pressure decreases, the piston and the pressure relief valve are resealed until the oil pressure again rises above the preset pressure. This modulating action between the needle valve and piston is continuous while the pump is operating. Although the single-stage pump can be used for overhead piping installations, there is some danger of pump noise. Accordingly the two-stage pump shown in figure 2-17 is recommended.

adjusting screw to enable the operator to vary the pressure from 80 to 140 psi.

In the case of hum in the fuel tank, check the antihum diaphragm of the fuel pump. If it is broken or missing, replace it with one like that shown in figure 2-18.

Nozzle and Electrode Assembly. The nozzle and electrode assembly includes oil pipe, nozzle holder, nozzle and strainer, electrodes, insulators around the electrodes, a supporting clamp for all parts, and a static disk, as illustrated in figure 2-19.

The high-pressure gun-type nozzle is rated in gallons per hour (gph), and the rating is stamped into the side of it. The nozzle that is selected depends on the size of the furnace or boiler. The angle of the spray is also stamped into the side of the nozzle. The size of the firebox determines what the angle of spray will be. A long, narrow firebox requires a smaller spray angle than a short, wide firebox. When selecting a nozzle, insure that the angle of the spray will not cause the flame to strike the sides or back of the firebox.

Two-stage fuel units. The two-stage fuel unit is very much like the single-stage unit, but it contains two complete pumping units. One pump lifts oil from the tank to the unit and delivers it to the second pump, which applies the required nozzle pressure. This two-stage unit is recommended for use with all outside underground tank installations as well as for the inside tanks connected to the burner through overhead piping. You should use a two-pipe system with a two-stage fuel unit. The pressure regulating valve has an

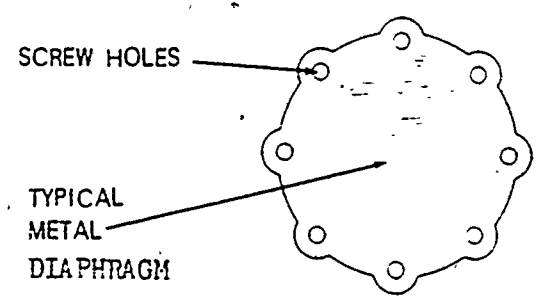


Figure 2-18. Antihum diaphragm.

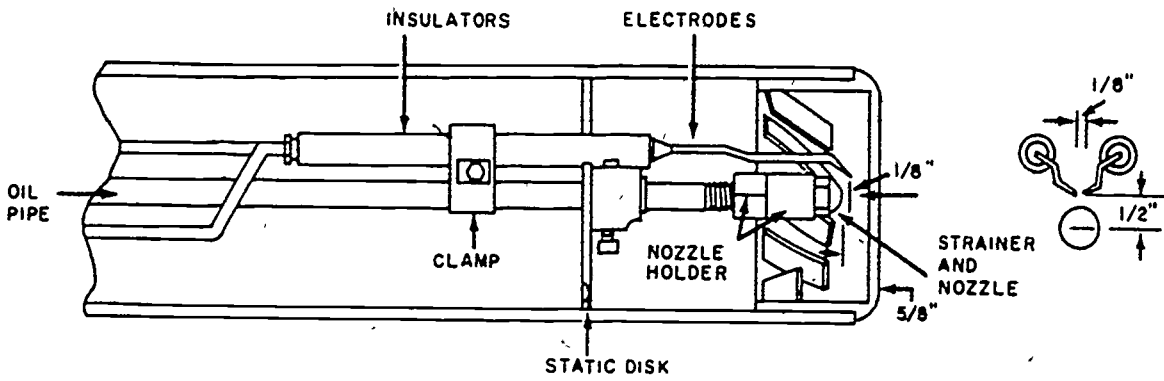


Figure 2-19. Nozzle and electrode assembly.

Exercises (413):

From the following given statements, select those that identify components of a gun-type oil burner. Indicate applicable statements by placing an X in the blank provided.

- ___1. The fan and fuel pump are driven by a component electric motor.
- ___2. Replacement motors must be from the same manufacturer.
- ___3. The component that supplies combustion air is the fan.
- ___4. The component that supplies combustion air is the blower.
- ___5. The unit used to step-down the electrical voltage is the ignition transformer.

- ___6. The electrical spark used to ignite the oil is produced by the ignition transformer.
- ___7. The component that forces oil through the nozzle is the single-stage fuel unit.
- ___8. To eliminate tank hum, remove the pump antihum diaphragm.
- ___9. The nozzle and electrode assembly includes the oil pipe, nozzle and strainer, and electrodes.

414. Describe the process of fuel-oil distribution in low-pressure gun-type oil burners one stage and two stage.

We will discuss the low-pressure, atomizing,

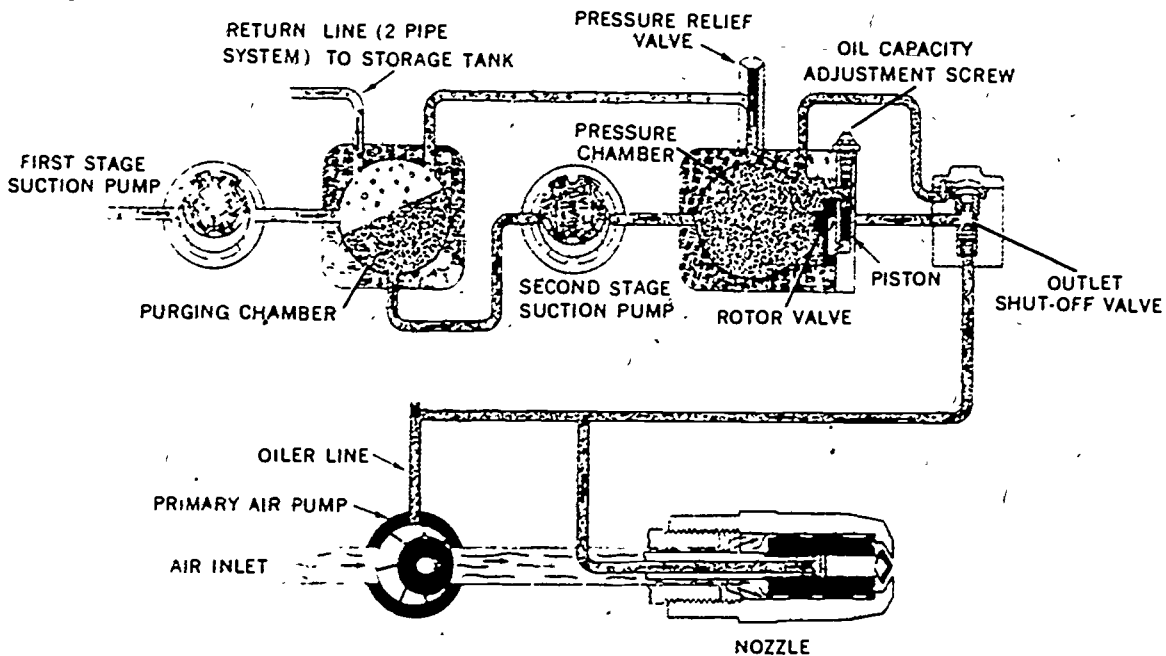


Figure 2-20. Flow diagram of two-stage low-pressure air atomizing burner system.

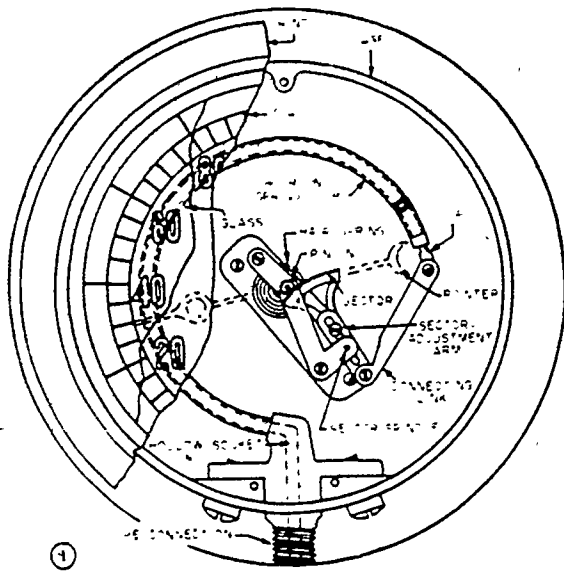


Figure 2-21. A typical Bourdon spring pressure gauge.

gun-type, oil burner distribution process first.

Low-pressure, atomizing, gun-type oil burners are of two kinds: one-stage (one pipe) and two-stage (two-pipe). Each has a specific use.

One-Stage Fuel Unit. The one-stage unit has only one pumping unit. Gravity delivers the fuel oil into the pump, which builds sufficient pressure (as explained below for the second pump on the two-stage model) to operate the system. The single-stage unit is most suitable for plants which have the fuel oil tank high enough above the pump to provide gravity fuel feeding.

Two-Stage Fuel Unit. The two-stage unit has two complete pumping units. It is recommended for underground-tank installations and inside tanks connected to the burner through overhead piping. The flow diagram in figure 2-20 illustrates the two-stage, low-pressure, air atomizing system.

Fuel delivery. The fuel unit employs a two-stage, fuel-pump system. The first-stage pump draws the fuel oil from the storage tank and discharges it into a purging chamber. The second-stage pump draws the oil from the bottom of the purging chamber and forces it into the pressure chamber where it builds enough pressure to operate the hydraulically motivated metering piston and open the shutoff valve, so that the metered oil flows to the nozzle. When the first-stage pump draws the oil from the storage tank, it creates a vacuum which causes flash gases (or air) to

form in the fuel unit. This air collects in the purging chamber and is drawn back into the storage tank.

Pressure. The oil in the pressure chamber is kept at 25 to 35 pounds pressure; a pressure relief valve in the pressure chamber discharges into the purging chamber to keep the pressure at the set level. From the pressure chamber, the oil is forced through the ports of a rotating valve, past a metering piston, to the nozzle, reaching there with a pressure reduced to practically zero. The oil activates the metering piston that establishes the firing rate of the burner by measuring the exact amount of oil flowing to the nozzle.

Volume. The length of the piston stroke positively controls the volume of metered oil. The volume can be adjusted from .50 to 3.00 gallons per hour (gph) by turning the screw clockwise to shorten the stroke and reduce the firing rate, or counterclockwise to lengthen the stroke and increase the firing rate.

Oil shutoff valves. The oil shutoff valve opens when the burner starts, permitting the metered oil to flow to the nozzle; it closes when the burner stops so that oil does not drip from the nozzle when the burner is idle. The valve operates in the following manner. When hydraulic pressure in the fuel unit pressure chamber reaches 18 to 22 pounds, it presses against a synthetic rubber diaphragm to actuate a push rod that forces the valve off the seat. When the pressure lowers to about 10 pounds, a calibrated spring presses the valve back against the seat and holds it firmly until increased pressure forces it open again.

Primary air. A vane-type primary air pump supplies a small volume of primary air to the inside of the nozzle at a pressure of approximately 1-3/4 psig. This air mixes with the metered oils to form a very fine atomized mixture which discharges from the nozzle orifice and mixes with the secondary air in the combustion chamber.

Air pump lubrication. To lubricate the primary air pump, divert a very small quantity of metered oil through the pump. Then pass it with the air to the nozzle where it combines with the main flow of metered oil. Oil flows to the air pump at approximately 18 to 30 drops a minute. The factory-set rate seldom requires adjustment.

Exercises (414):

1. Describe the fuel-oil flow in a low-pressure gun-type oil burner, using a one-stage fuel unit.

2. Describe the fuel-oil flow in a low-pressure gun-type oil burner, using a two-stage fuel unit.

415. State the methods of igniting fuel oil and describe the electrical method of ignition for an oil burner.

There are many methods in which to ignite fuel oil. Depending on the burner type, oil can be ignited by a gas pilot flame, electrically and on very large units by a small domestic type burner. The most prominent is the electric ignition system that we will discuss here.

On oil burners the electric ignition system consists basically of two components: a step-up transformer in which the standard 115-volt line on the primary side is stepped up to approximately 10,000 volts on the secondary side, and an electrode assembly provides a combination insulated porcelain "holding surface" and steel electrode working and gapping areas.

Transformers. A transformer is a unit capable of changing an electrical current from a low to a high potential without changing the current energy.

The ignition transformer consists of a box-like structure, approximately 4½" x 4½" x 5½" in size that houses such components as an interference eliminator, the secondary terminals, the primary wire connections, and a moisture-proof filler compound.

To properly mount the transformer to the burner housing, a suitable mounting plate must be attached. These come in various sizes and shapes, and are designed to fit most known burner casings.

Electrode Assembly. The electrode assembly is a team of precisely engineered parts in which a spark, resulting from a combination of two properly positioned, "gapped" electrode tips, and high voltages produced in an effective step-up transformer, join together to produce an ignition. This arc of electricity ignites the prepared oil being pumped into the unit's combustion area.

An electrode consists of two parts—the insulator or porcelain and the metal electrode rod or tip. The insulator or porcelain section is a round or square piece of glazed or unglazed ceramic, carefully made and prepared. The insulators, made in two major

sizes (7/16 inch and 9/16 inch), are used in almost all oil burners. They also come in various lengths starting with 4 inches. The porcelains serve a dual function. They securely hold or position internally the electrode rods and tips: at the same time, they serve as insulators that protect the metal rod passing through it from surrounding metal surfaces.

The electrode rod or tip is made of a low-resistance high-nickel-alloy steel, carefully milled at both ends of the rod for top grade performance. The tip is normally rounded to provide a steady, even, high-voltage arc. The butt is threaded to receive one of the ignition terminals.

Exercises (415):

1. State the methods used to ignite the fuel oil used in an oil burner.

2. Describe the electrical ignition method.

2-2. Operation and Maintenance of Oil Burners

Satisfactory heating with oil burners depends not only on the selection of suitable equipment, proper installation, operation and maintenance, but also on the conditions of the building where the heat is to be utilized. The condition of the building is particularly important with respect to heat loss and the location of the heat sources. The oil burner must be installed by qualified mechanics, in strict accordance with the manufacturers instructions. Details of combustion chamber size and shape, and the positions of the burner and auxiliary equipment can be found in installation manuals that are furnished by the oil burner manufacturers.

416. Given oil burner operation and trouble conditions, match the trouble to the cause or remedy.

Operation. The main consideration when operating oil burners is to follow the recommendations and procedures furnished

by the manufacturer of the specific unit when operating any type of domestic or industrial oil burner. After the burner has operated long enough to warm the combustion chamber, you should make an air adjustment as you watch the flame for proper color. After you have adjusted the fire visually as well as you can, analyze the combustion with a portable

flue-gas analyzer to insure proper combustion. Then allow the burner to operate normally.

The following are common troubles along with their causes and remedies that you will encounter during operation of oil burners. Although these are based on domestic-type units, the same type of problems can occur with industrial units.

Trouble	Cause	Remedy
1. Oil Failure.	<ul style="list-style-type: none"> a. Oil storage tank empty. b. Nozzle clogged. c. Strainer clogged. d. Internal bypass plug may not be in place when installing the burner with a return line. e. Restriction in suction line other than clogged strainers. f. Vacuum leak in the suction line. 	<ul style="list-style-type: none"> a. Refill. b. Remove the burner assembly. Clean or replace the nozzle. c. Clean the line strainer, the fuel unit strainer, and/or the nozzle strainer. d. Install the bypass plug. e. Use a vacuum gage to check the line back to the tank. Use a bicycle pump, attached to the burner end of the line, to blow back any obstructions in the line. f. Locate and repair the leak. In extreme cases (e and f) it may be necessary to run a new suction line. g. Replace the seal.
2. Motor failure.	<ul style="list-style-type: none"> a. Bypass plug installed in fuel unit when used with single-pipe system, thereby building up excessive pressure and stalling the motor. May blow the fuses. b. Motor starting switch dirty or sticking. c. Motor condenser is burned out. d. Motor is shorted or burned out. 	<ul style="list-style-type: none"> a. Remove the bypass plug. Check the fuel unit and the motor for possible damage. b. Remove the motor end bell and examine the switch assembly. If the remedy is not obvious, replace the switch assembly or change the motor. c. Short out the condenser. If the motor runs, replace the condenser. d. Replace the motor with one of same rotation.
3. Ignition failure.	<ul style="list-style-type: none"> a. Transformer terminals are not connected. b. Electrodes are not set properly. c. Carbon on the electrodes. d. Weak transformer. e. Electrodes are cracked or grounded. 	<ul style="list-style-type: none"> a. Connect and properly tighten the terminals. b. Adjust the setting. c. Clean and check the setting. d. Replace transformer. e. Replace the electrodes and adjust the setting.
4. Faulty control operation.	<ul style="list-style-type: none"> a. Stack control helix is badly sooted. b. Stack temperature is too low because the fire is too small for the heating load. c. Too frequent cycling of the thermostat. 	<ul style="list-style-type: none"> a. Remove the control and clean the helix with a small brush. b. Increase the gph and adjust the fire for boiler size. c. Adjust thermostat for longer running cycles. Check wiring to thermostat heat anticipator.
5. Irregular stack temperature.	<ul style="list-style-type: none"> a. Change in draft. b. Downdraft caused by obstruction such as trees or insufficient chimney height. c. Bad draft due to leaks in the chimney. d. Fluctuating flame. 	<ul style="list-style-type: none"> a. Install the draft regulator. b. Remove the obstruction. Increase the chimney height or install an H-hood. c. Other openings should be closed. d. Check burner operation.



Trouble	Cause	Remedy
6. No electrical current to burner circuit.	<ul style="list-style-type: none"> a. Fuse blown. b. Difficulty with the power source. c. Break in the wiring or bad connection. d. Defective controls. 	<p>Nozzle may be partially clogged or there may be water in the oil. Fuel unit pressure may be set too low so that the oil delivery is not uniform.</p> <ul style="list-style-type: none"> a. Replace the fuse, and determine what caused it to blow. b. Notify the electrician. c. Check it with test equipment and repair it. d. Repair or replace.
7. Burner fails to shut off.	<ul style="list-style-type: none"> a. Controls improperly wired. b. Thermostat out of calibration. c. Wires shorted out. 	<ul style="list-style-type: none"> a. Rewire the controls. b. Calibrate the thermostat. c. Check with the test equipment and repair.
8. Smoke, odor, and fumes.	<ul style="list-style-type: none"> a. Improper burner adjustment. b. Bad draft creating pressure in the chamber. c. Air cone burned away or fallen out. 	<ul style="list-style-type: none"> a. Check the air and oil adjustments. b. Check the overfire draft with the gage and correct. c. Check the air cone on the end of the blast tube. Correct or replace it.
9. Burner puffs when starting.	<ul style="list-style-type: none"> a. Electrode is not properly set. b. Weak spark due to a ground in the burner assembly. c. Weak spark, or no spark at all. 	<ul style="list-style-type: none"> a. Reset the electrodes. b. Check and correct. c. Check out the transformer and replace it if necessary.
10. Burner short cycling.	<ul style="list-style-type: none"> a. Limit control is cutting off and on. b. Thermostat differential is set too close. 	<ul style="list-style-type: none"> a. Check the wiring and location of the limit control; also check the thermostat. b. Adjust for wider differential. a. Adjust the fuel pump for 100 pounds of pressure. Set the air shutter for the proper smoke reading. b. Check the chimney and smokepipe. c. Adjust to produce an orange flame with no chimney smoke and no more excess air than necessary.
11. Improper flames.	<ul style="list-style-type: none"> a. Oil pressure too high or too low. b. Poor draft. c. Improper adjustment of the burner air shutter. 	<ul style="list-style-type: none"> a. Adjust the fuel pump for 100 pounds of pressure. Set the air shutter for the proper smoke reading. b. Check the chimney and smokepipe. c. Adjust to produce an orange flame with no chimney smoke and no more excess air than necessary. d. Replace the worn parts. Check the alignment. e. Relieve the strain by installing flexible sections at the burner. f. Reassemble the fuel pump. d. Install an antihum diaphragm. a. Adjust to the proper flame. b. Readjust for a -0.02-inch overfire draft. c. Eliminate the air leaks in the furnace or boiler. Adjust the draft and improve the flame. d. Increase to the proper gph. e. Decrease fire to proper gph. f. Check and reset the controls. g. Clean heat exchanger areas.
12. Burner noisy.	<ul style="list-style-type: none"> a. Motor drive coupling is loose or worn. b. Rigid electric or oil pipe connections at the burner. c. Fuel unit is not reassembled properly. d. Tank hum. 	<ul style="list-style-type: none"> a. Adjust to the proper flame. b. Readjust for a -0.02-inch overfire draft. c. Eliminate the air leaks in the furnace or boiler. Adjust the draft and improve the flame. d. Increase to the proper gph. e. Decrease fire to proper gph. f. Check and reset the controls. g. Clean heat exchanger areas. a. Increase the gph to proper size. b. Adjust burner for proper CO₂.
13. Excess fuel consumption.	<ul style="list-style-type: none"> a. Poor atomization. b. Excessive draft. c. Low CO₂ (high excess air). d. Fire is too small for the boiler or furnace. e. Fire too large for boiler or furnace. f. Improper setting of controls. g. Heat exchanger areas caked with carbon and slag. 	<ul style="list-style-type: none"> a. Increase the gph to proper size. b. Adjust burner for proper CO₂.
14. Excessive electrical consumption.	<ul style="list-style-type: none"> a. Fire may be set so low that burner operates continuously to heat the building. b. Bad adjustment, low CO₂. 	<ul style="list-style-type: none"> a. Increase the gph to proper size. b. Adjust burner for proper CO₂.



Maintenance. Some of the common services that should be accomplished on oil burners are listed next. These services should be scheduled and performed at the intervals recommended by the manufacturer of the oil burner. It is necessary for you to remove soot and carbon deposits from the nozzle. A nozzle is a delicate unit and should be handled with care. Use safety solvent to clean the nozzle. Compressed air also can be used for cleaning; however, goggles should be used to protect your eyes. Also, clean the fuel lines, storage supply tanks, strainers, pressure regulator valves, and fuel pumps. Check all electrical wiring. Lubricate electric motors and other units requiring lubrication, being careful not to over oil. When you clean soot from the firebox, refractories, flues, and chimney, you should follow the manufacturer's instructions.

Gas burners should always be equipped with safety pilots ("Flame Rods," "Protect-O-Glow," or some other system) that insures lighting. The pilot is a flame or igniting device that lights the main burner. If the pilot flame is extinguished, you must purge and ventilate the furnace before lighting it again.

If propane or butane gas is used, be sure to ventilate the furnace each time it is fired. Propane and butane gases are heavier than air and extra time is required for diffusion and removal of accumulated gas pockets. These gases tend to settle in the bottom of the firebox or the combustion chamber.

417. Name the instruments used in gas measurement, specify the classification of gas burners and list the types of premixing burners.

Exercises (416):

Match the given trouble conditions in column A to the cause or remedy listed in column B by writing the corresponding letter in the blank provided.

- | Column A | Column B |
|--|--|
| — 1. Oil failure. | a. Fire set so low burner operates continuously. |
| — 2. Motor failure. | b. Nozzle is clogged. |
| — 3. Ignition failure. | c. Thermostat differential is set too close. |
| — 4. Faulty control operation. | d. Starting switch is dirty or sticking. |
| — 5. Burner puffs when starting. | e. Reassemble the fuel pump. |
| — 6. Burner short cycling. | f. Connect and properly tighten the terminals. |
| — 7. Burner noisy. | g. Weak spark, or no spark at all. |
| — 8. Excessive electrical consumption. | h. Check wiring to heat anticipator. |
| | i. Replace the fuse. |

Usually gas-burning systems are classified according to the amount of gas pressure each one utilizes. These are classed as low-pressure and high-pressure systems.

The low-pressure systems are designed for relatively low capacities, and they operate with the natural gas at pressures of 2 ounces to 3 psi. A multijet burner provides maximum heat from the gas and air at the pressure available. The gas is conveyed to several burner units from a manifold that is installed between the supply line and the burners. The manifold must be used when several burners are operating in one unit.

The high-pressure burner operates on pressures of 1 to 30 psi. Because the pressure in a gas main that serves a large plant can vary as much as 30 to 50 psi, the high pressure is reduced and maintained by means of a pressure reducing valve.

Measuring Gas Pressure. Since a burner may be designed for a specific pressure, it is necessary to get gas pressure at a certain number of pounds per square inch. Also, it is more economical to use gas at a low pressure, provided the heating unit will produce maximum heat. Usually, the gas pressure can be adjusted at the pressure regulator. Various vacuum and pressure gages are used to determine gas pressure. The most important and commonly used gages are the Bourdon pressure gage and the manometer.

Bourdon gage. The essential element of the Bourdon gage is an oval metal tube, curved along its entire length to form almost a complete circle. One end is closed and connected to linkage with a sector and pinion

2-3. Types of Gas Burners

Natural gas is a nearly ideal fuel because it burns easily, requires comparatively simple equipment and labor, is almost free of noncombustibles, and is clean. It is a comparatively dangerous fuel, however, because it mixes easily with air and burns readily. Extreme care must be exercised to prevent or stop any leakage of the gas into an unlighted furnace or into the boiler room. All gas burners should be approved by the American Gas Association and installed in accordance with applicable standards of the National Board of Fire Underwriters.

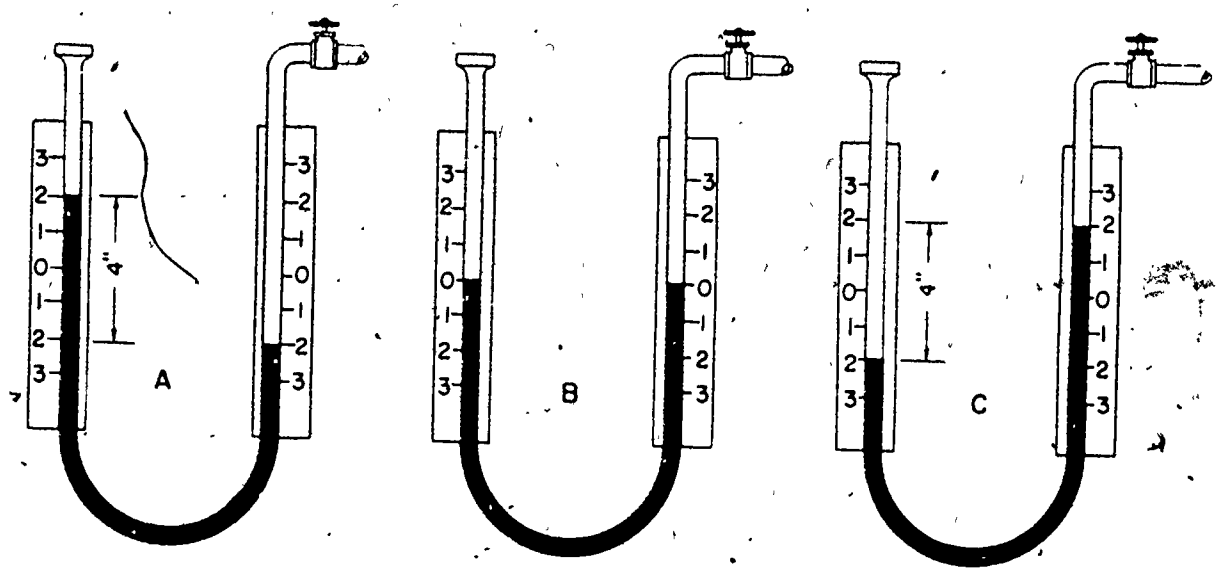
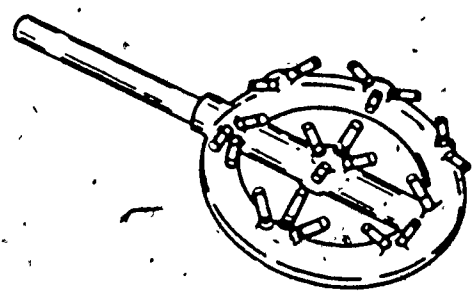


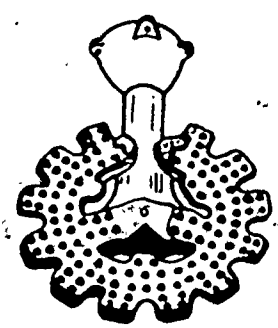
Figure 2-22. Open manometers having different readings.

and the other end is connected to the source of pressure to be measured. The application of pressure to the tube causes the linkage end to move a calibrated amount. This movement is transmitted by the sector and pinion to a pointer moving over a graduated dial. The dial is calibrated, or scaled, to read directly in pounds per square inch. See figure 2-21.

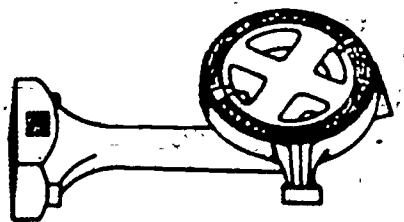
Manometer. Another instrument used to measure pressure and vacuum for gas burners is called a manometer. It is a U-shaped glass tube 30 inches long on each leg and half filled with water or mercury, as shown in figure 2-22. In detail B of figure 2-22, the manometer is at a neutral stage; that is, the pressure on both legs is equal. Illustration A



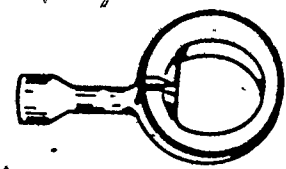
INDIVIDUAL JET



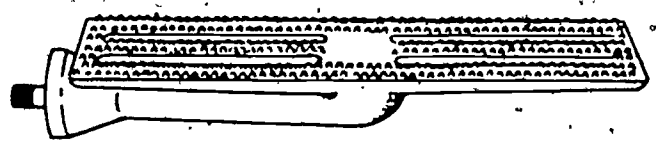
DRILLED PORTS



RIBBON PORTS



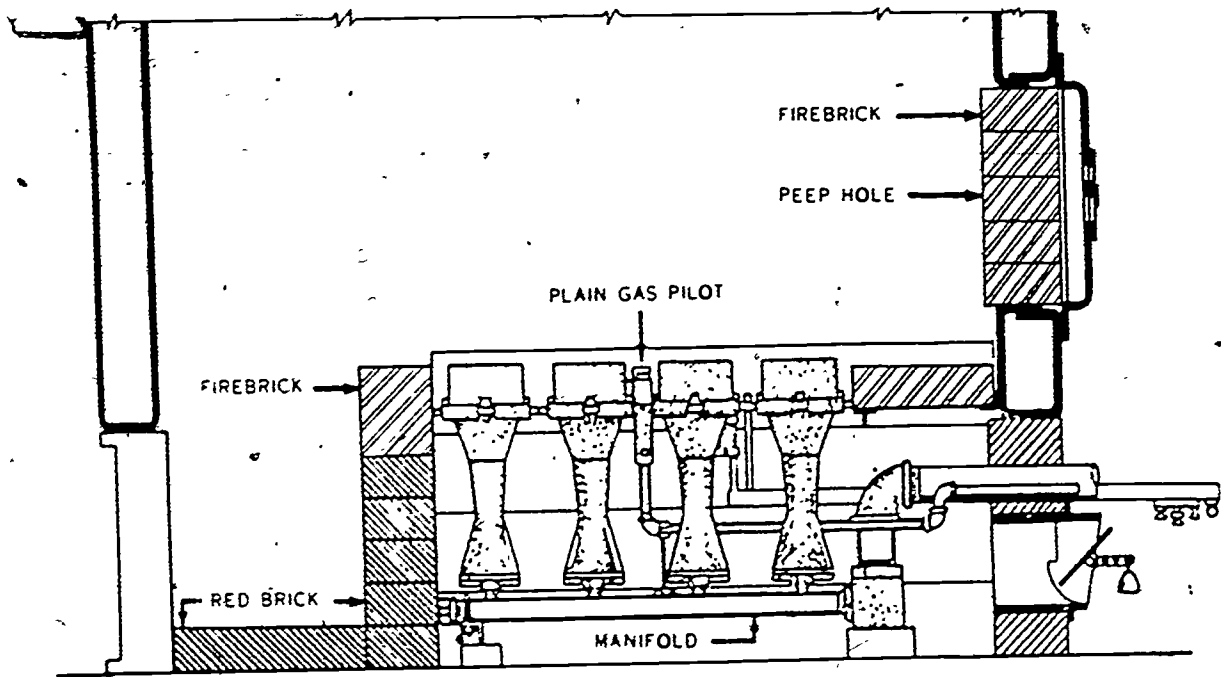
SLOTTED PORT



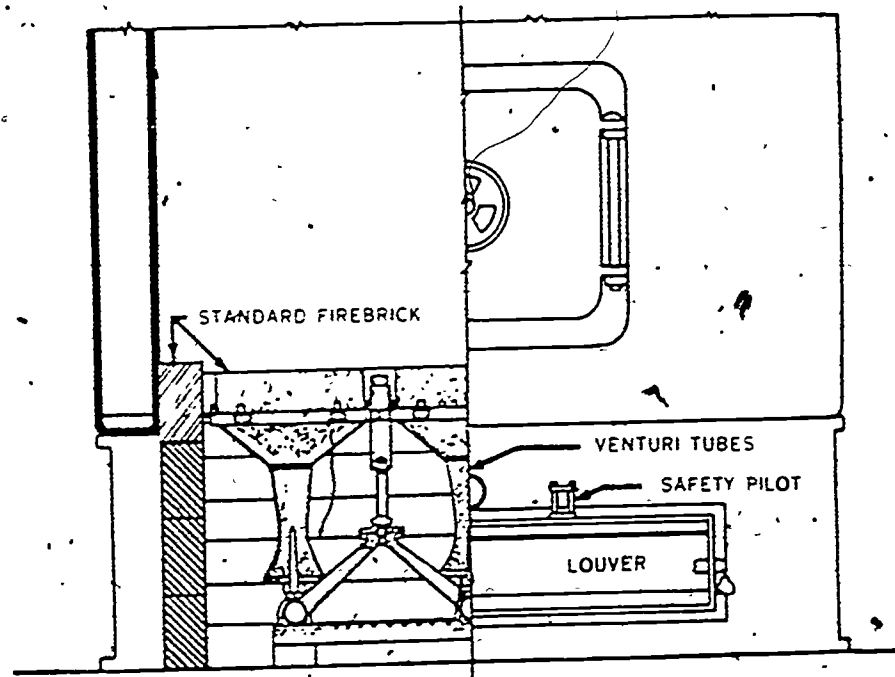
RAISED PORTS

Figure 2-23. Various shapes of burners.

267



SIDE VIEW



FRONT VIEW

Figure 2-24. Upshot gas burner installation.

shows a manometer connected to a gas pressure line and indicates a vacuum differential of 4 inches. This static pressure is referred to as inches of water or mercury, depending on the type of liquid used in the manometer tube. Although the pressure is read in inches of water or mercury, it may

also be expressed in ounces or pounds per square inch.

Premixing Burners. Although gas burners are generally classified according to the pressure they use, they can also be classified according to how each mixes the gas and air together. In the premixing type burner, air

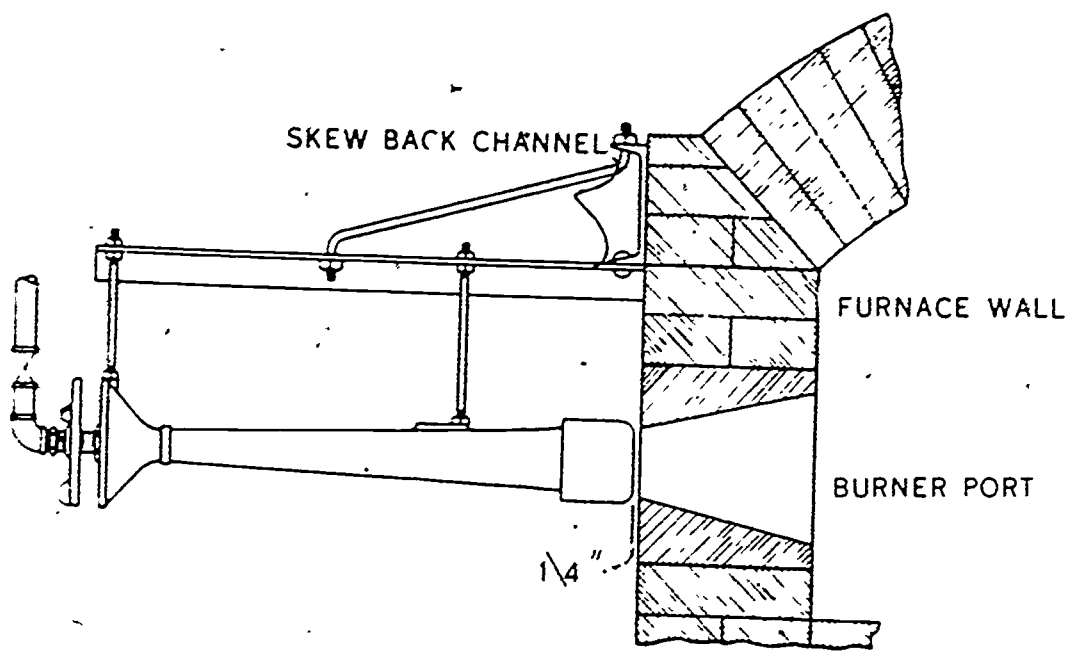


Figure 2-25. An inshot gas burner.

(primary air) and gas pass together and are mixed as they flow through a tube (usually a venturi) to the burner head. Additional air (secondary air) is required for complete combustion. Burners of this type vary from the common atmospheric burner used in gas appliances to the high-pressure gas burners used for industrial purposes. The following are various types of premixing gas burners.

Bunsen. Bunsen gas burners are designed in many different sizes and shapes, some of which are illustrated in figure 2-23. The burner design is determined largely by the shape of the combustion chamber in the heating unit, the firebox, and the method used for mixing the air with the gas. All of the burners illustrated in figure 2-23 are usually considered to be the low-pressure type.

Radiant. Radiant gas burners are horizontal firing, usually through a large number of small orifices or spuds. These orifices inject and control a stream of gas through hollow refractory blocks that have a number of openings, in the form of various designs, in the front or heating side. The flames burn directly in the hollow refractory blocks and extend almost the full length of the blocks, depending upon the amount of gas passing through the orifice.

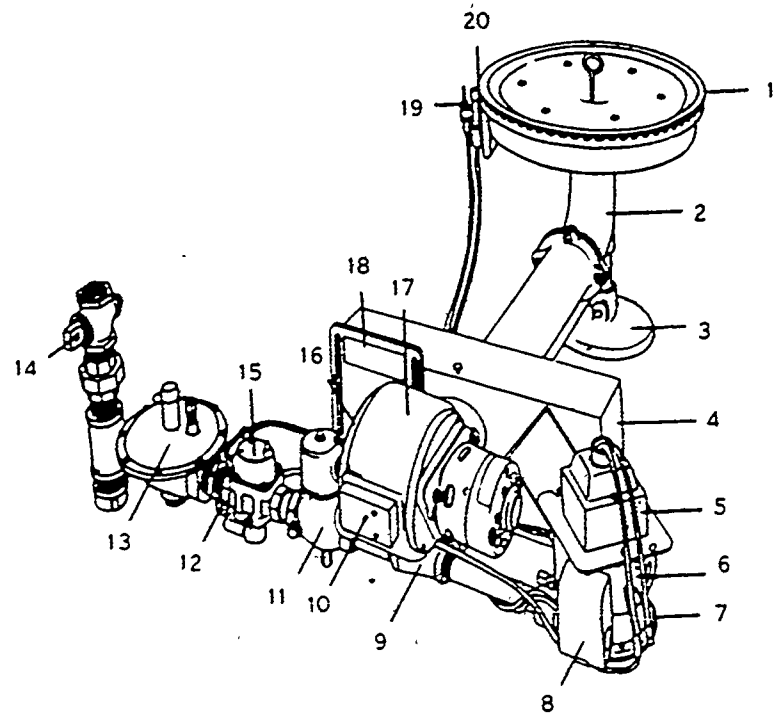
Open brick baffles are sometimes located directly behind the burners at about

two-thirds normal flame height. These baffles are built so that the front area is completely open, requiring the flame to pass through the baffles close to a very hot refractory surface. The pilot lights are usually placed in the center of the row of orifices.

Upshot. Upshot or vertical gas burners are usually built in units. Each unit is composed of a venturi or mixing throat that is mounted directly over an orifice or spud in the manifold. The burner top surfaces vary widely in design. Some have drilled or slotted tops; others have brick or refractory mounted on a grid or slotted spacer as shown in figure 2-24. In each type, however, the gas-air mixture must pass through a small port before it is ignited, thus offering protection against flashback.

Inshot. Inshot gas burners are usually the horizontal type. A typical inshot gas burner is illustrated in figure 2-25. These burners are similar in construction to the upshot type. The advantage of this type of burner is that it can be installed in the lowest part of the furnace firebox. This greatly increases the heating surface exposed to the flame and causes the maximum amount of heat to be extracted from the fuel being burned. These burners are also easier to install in an existing firebox, since their construction makes them a small and compact unit.





- | | |
|--------------------------|-------------------------|
| 1. Burner Head | 11. Automatic Gas Valve |
| 2. Venturi | 12. Manual Pilot Valve |
| 3. Burner Leg | 13. Pressure Regulator |
| 4. Adjustable Front | 14. Main Gas Valve |
| 5. Transformer | 15. Safety Shut-Off |
| 6. Conduit Box | 16. Air Shutter |
| 7. Mercury Blower Switch | 17. Combustion Blower |
| 8. Junction Box | 18. Burner Door |
| 9. Gas Metering Valve | 19. Thermocouple |
| 10. Air Safety Switch | 20. Gas Pilot |

Figure 2-26. A premix gas burner.

Some premixing burners are equipped with an electric motor and blower that is used to compress the air and mix it with gas at the same time. An illustration of a typical premix type burner is shown in figure 2-26. Burners of this type operate satisfactory in combustion chambers that do not have good refractory surfaces. The gas flow is through the main gas valve 14, pressure regulator 13, manual pilot valve 12, automatic gas valve 11, and through metering valve 9, and is then mixed with air from combustion blower 17. The mixture travel through venturi 2, and to the burner head 1. Item 19 is the thermocouple to safety shut-off 15, which shuts the gas in event pilot 20 is not

ignited. Combustion is regulated by controlling the air with air shutter 16.

Nozzle-Mixing Type. In this type of burner, air and gas are separated and do not mix until they are released to the combustion chamber. In some burners, the velocity of the gas emerging from the individual burner jets is used to draw the primary air into the combustion area, others use draft fans to supply the incoming air (primary air) stream. An example of this style of design is the register-type burner shown in figure 2-27. This figure shows a combination gas and oil burner. However, this type of burner can also be obtained as a straight gas burner.

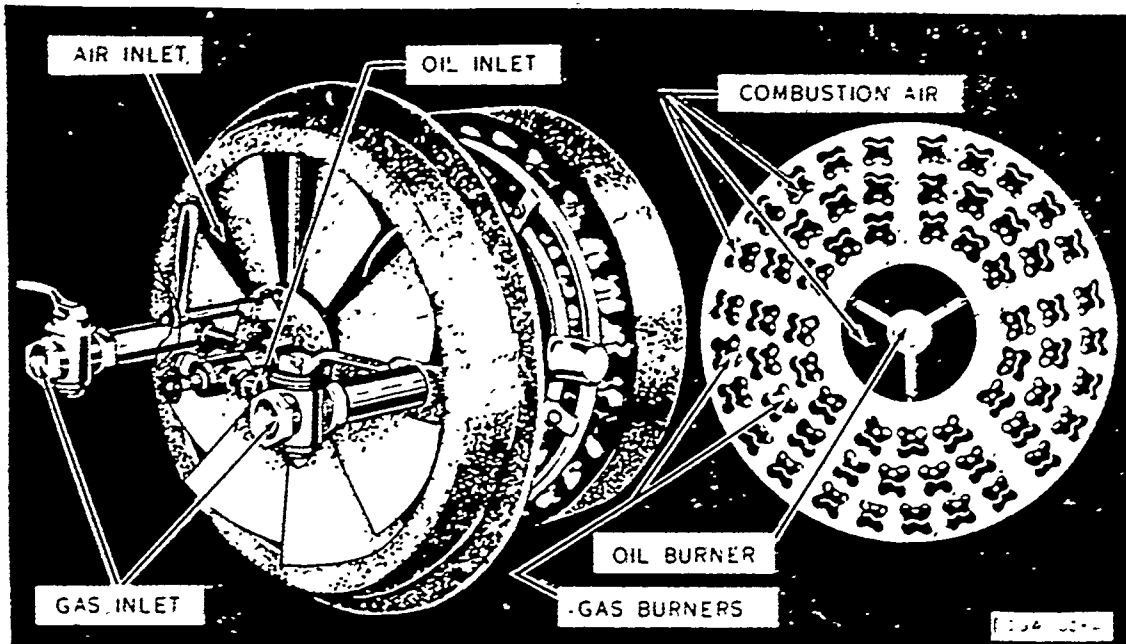


Figure 2-27 Combination gas-oil burner.

Combination Gas and Oil Type. There are also combination gas and oil burners in which the gas burner is of the nozzle-mixing type. That is, the gas burner is set in an air register along with the oil burner. Figures 2-28, 2-29, and 2-30 show three variations of the register burner. Certain types of gas burners are designed to be inserted in the register when only gas is to be burned, while others may

remain when oil is to be burned. The burner air registers are used to control flame shape and are not intended to regulate air flow quantity or fan speed. The gas is generally supplied at pressures above 8 ounces psig.

Exercises (417):

1. Name the instruments used to measure gas pressure.

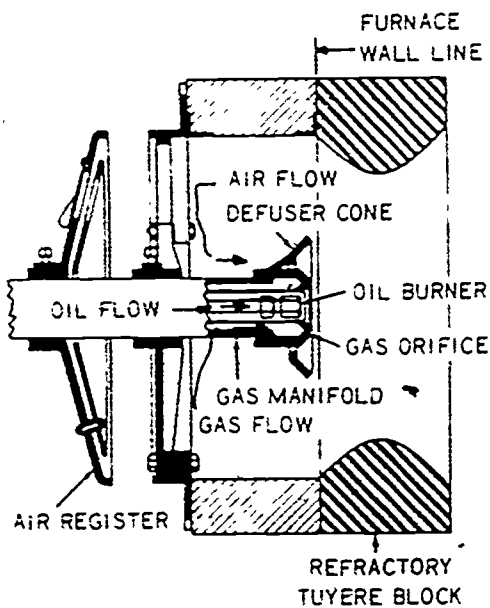


Figure 2-28. A register-type burner with gas orifices centered in airstream.

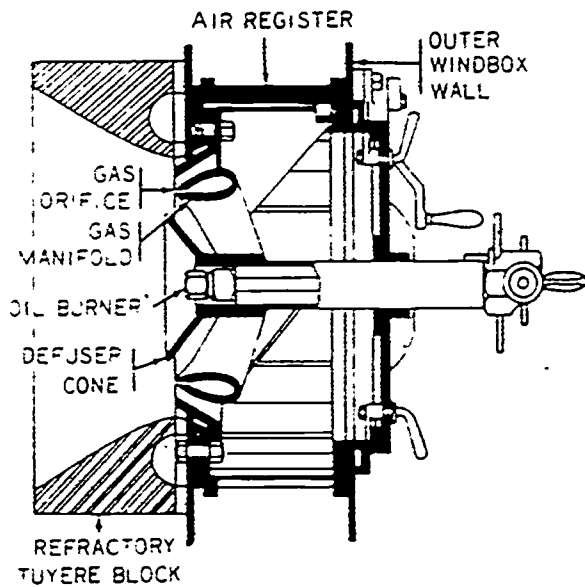


Figure 2-29. A register-type burner with gas manifold dividing airstream.

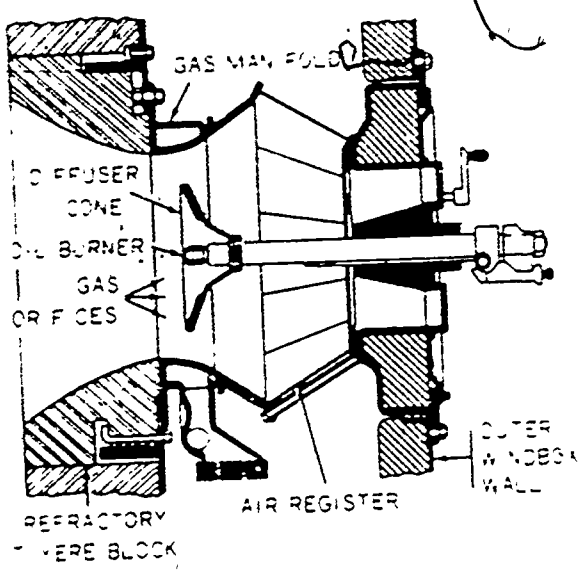


Figure 2-30 A register-type burner with gas orifices at periphery of airstream.

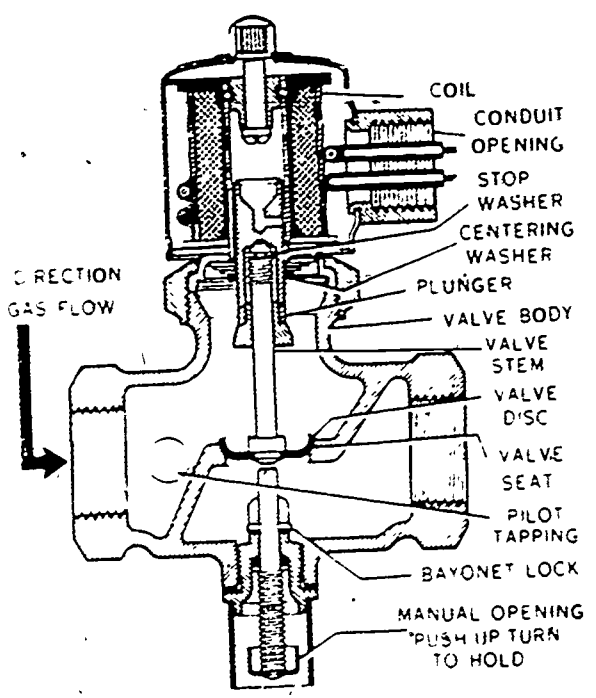


Figure 2-32. A standard gas solenoid valve.

2. Specify the classification of gas burners.

3 List the types of premixing burners.

418. List the components of a gas burner fuel assembly and mark statements that show the correct purpose of each component given.

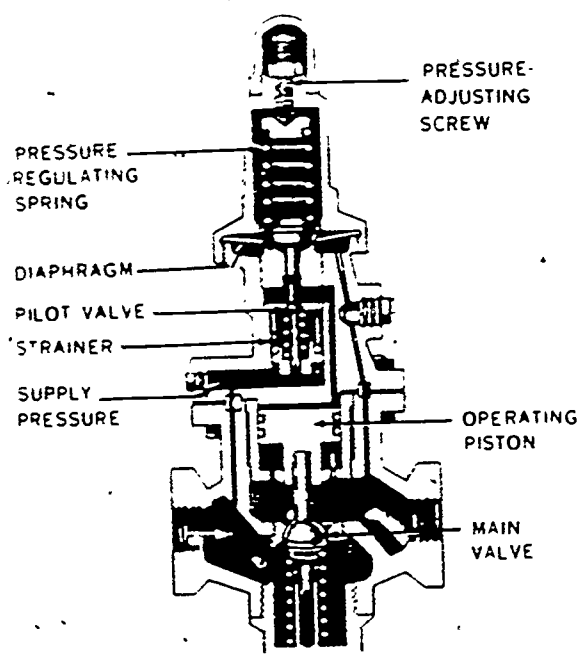


Figure 2-31. A gas pressure regulator.

We mentioned a number of burner components under the previous learning objective. We will now describe the purpose and operation of the components.

Manifold. The manifold is the part of the gas supply system that feeds gas to the spud. There can be numerous spuds connected to the manifold.

Spud. The main function of the spud is to house (hold) the orifice. It is connected to the manifold.

Orifice. The orifice is generally connected to the spud. On certain burners it is connected to the manifold. It can either be connected by screw threads or by sliding into the spud section. The size of the orifice determines the amount of gas that will go to the burner. The orifice is replaceable and is changed to change the burner output.

Venturi Tube or (Mixing Tube). The venturi is constructed of cast iron or cast steel. Gas enters the venturi tube through the orifice and the primary air enters at the mixing head. Both gas and air enter the throat and then pass on to the mixing tube where they are mixed together. The venturi tube

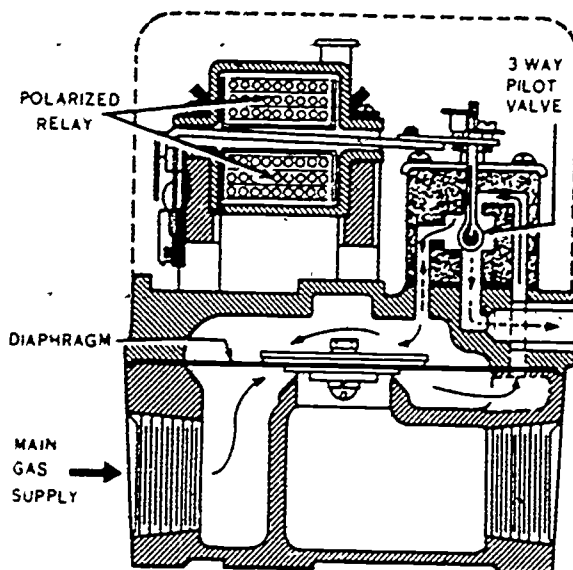


Figure 2-33. A diaphragm gas valve.

also houses an air shutter where primary air supply can be adjusted.

A gas burner assembly usually includes the following units: manual gas valve, gas pressure regulator, automatic gas valve, pilot light, thermocouple, and relay. A main gas cock must be installed ahead of the burner assembly.

Manual Shutoff Valve. The manual gas valve on a heating unit is usually installed next to the gas pressure regulator. It is used to shut off the gas to the heating unit in case some of the controls are being repaired or replaced.

Pressure Regulator. The gas pressure regulators used in domestic gas-heating systems are usually of the diaphragm type, like the one illustrated in figure 2-31. This gas pressure regulator maintains the desired pressure in the burner as long as the gas main pressure is above the desired pressure. The pressure spring holds the piston down off its

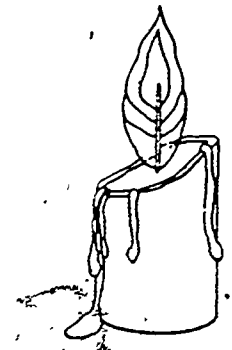
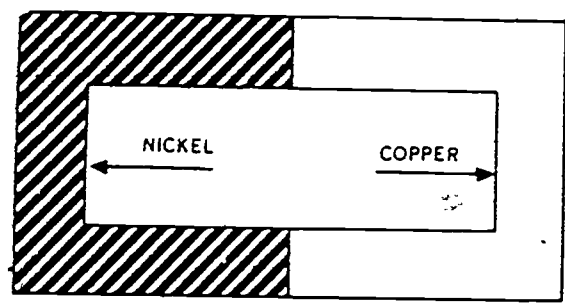


Figure 2-34. The principle of a thermocouple.

seat when the gas pressure in the burner is low. A gas pressure above the desired amount will force the diaphragm up. This allows the piston spring to reseat the piston and stop the gas flow until the pressure in the burner drops. The regulator is thus closed every time the burner pressure gets above the desired amount. The setting of the regulator can be varied with the adjusting screw located at the top of it.

Solenoid Gas Valve. The basic principles of construction and operation applied in all solenoid gas valves are similar. However, the design of each individual unit differs somewhat from the others. The two most common types of solenoid gas valves are the standard solenoid valve and the combination solenoid valve.

Standard solenoid gas valve. The standard solenoid gas valve shown in figure 2-32 is of the electric type. It is suitable for use with gas furnaces, steam boilers, hot water boilers,

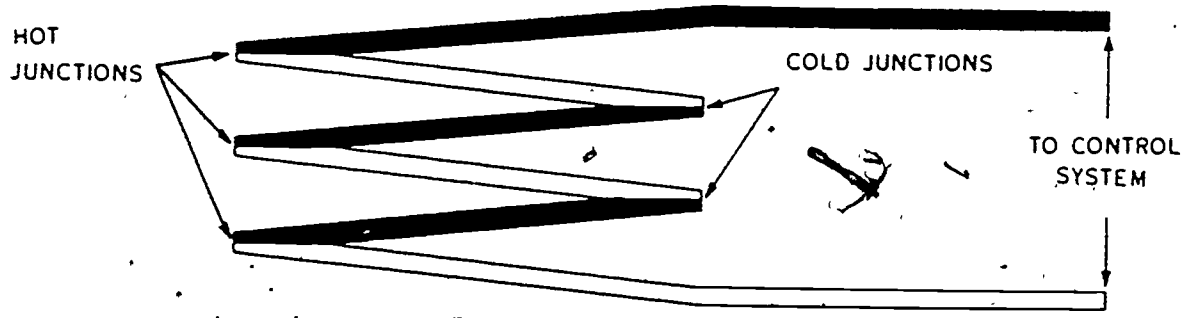


Figure 2-35. A thermopile.

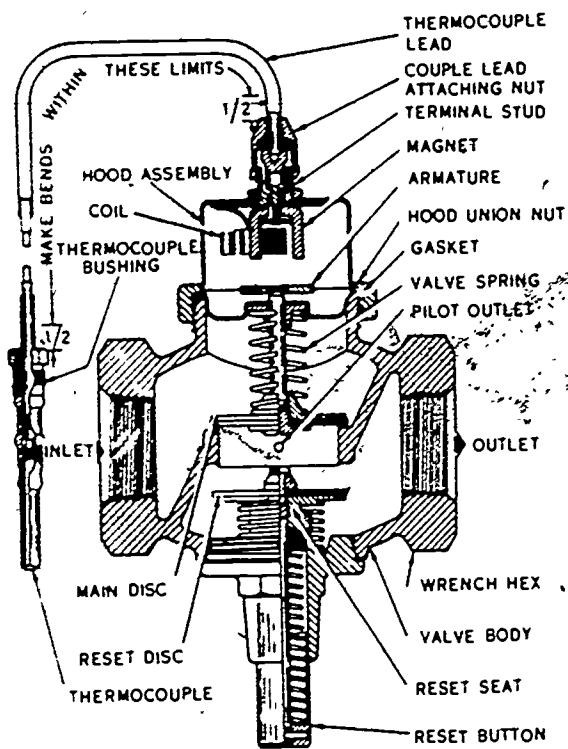


Figure 2-36 A typical thermocouple and valve relay assembly

interchangeably with a solenoid gas valve. Its main feature is the absence of valve noise when it is opening or closing. In this type of diaphragm valve the polarized relay energizes and opens the three-way valve, allowing the gas to flow out of the upper chamber of the unit. Reducing the pressure in the upper chamber in this manner causes the diaphragm to flex upward and open the gas valve. When polarized relay is deenergized, the three-way pilot valve allows the gas to flow into the upper chamber, thus increasing the pressure and closing the gas valve.

Pilot Light. The gas pilot light in a gas heating unit is a small continuous-burning flame that lights the main burner during normal operation of the heating unit. It is located near the main burner like the one shown in figure 2-26.

The gas flow to the pilot light is, in some cases, supplied by a small, manually-operated gas shutoff valve located on the main gas line above the main gas valve. In other cases, the gas can be supplied from the pilot tapping of a solenoid gas valve, as shown in figure 2-32. In more expensive heating units, the gas for the pilot light is often supplied by a thermocouple-controlled relay.

Thermocouple. A thermocouple is probably the simplest unit in the electrical field used to produce electric current by means of heat. It is constructed of two U-shaped conductors of unlike metals in the form of a circuit, as shown in figure 2-34. Suppose that these conductors were composed of copper and nickel respectively, and joined as shown in the figure; then two junctions between the metals would exist. If one of these junctions were heated by a flame, a weak electric current would be produced in the circuit of these conductors. A series of junctions can be arranged to form a thermopile to increase the amount of current produced, as shown in figure 2-35.

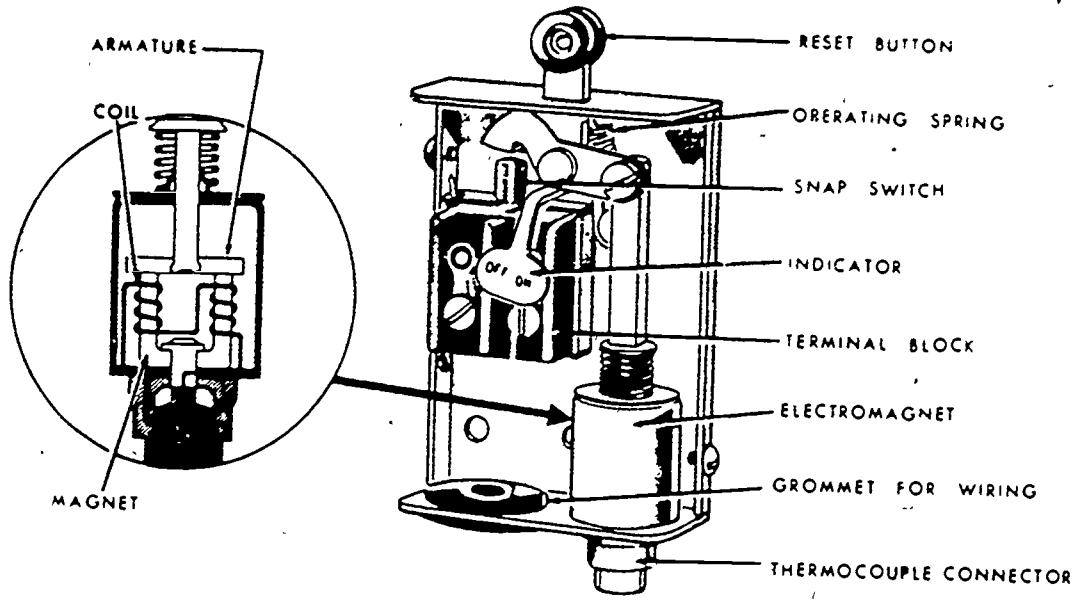
In the heating field, thermocouples and thermopiles are used to produce the electrical current that operates such units as heating unit gas valves, relays, and other safety devices.

The thermocouple is located next to the pilot light of the main gas burner, as shown in figure 2-24. When heated, it generates the electric current which holds open a gas valve, a relay, or other safety devices permitting gas to flow to the main burner. Immediately after the pilot light is extinguished, the thermocouple cools and current ceases to flow through the circuit, thereby deenergizing the coil and causing the solenoid valve to close and shut off the gas to the burner. These

conversion burners, and industrial furnaces. This valve operates when a thermostat, pressure control, or aquastat closes a circuit to energize a coil. The energized coil operates a plunger, causing the valve to open. When there is a current failure, the valve automatically closes, causing the gas pressure in the line to hold the valve disc upon its seat. To open this valve during current failure, it is necessary to use the manual opening device at the bottom of the valve. When electric power is resumed, you place the manual opening device in its former position.

Combination solenoid valve. The combination solenoid gas valve has a manual reset device that provides for manual operation of the valve during power failure. If the valve is manually opened during a power failure, the valve will automatically return to control of the thermostat when the power is resumed. Never use this valve with a mechanical forced warm air system without removing the manual reset. If the valve is manually opened during a power failure the furnace will overheat because the fan will be inoperative and therefore unable to remove the heat generated.

Diaphragm Valve. The diaphragm gas valve illustrated in figure 2-33 can be used



An electric switch-type relay.

CGB 123

Figure 2-37. An electric switch-type relay.

safety devices will not operate again until the pilot light is lighted and current is again generated by the thermocouple.

Thermocouple Control Relay. The thermocouple-operated relay, commonly called a pilotstat, shown in figure 2-36, is a safety device for gas-fired heating equipment. The thermocouple, when placed in the gas pilot flame, generates electricity. The electric current energizes an electromagnet that will hold a switch or valve in the open position as long as the pilot flame is burning. When the pilot flame goes out, because of high drafts or fuel failure, the electromagnet will be deenergized, thus closing and preventing the opening of the switch or valve. The closing of the valve or switch prevents the burner from filling the combustion chamber with unburned gases.

To relight the pilot light, it is necessary to push up the reset button at the bottom of the relay and allow the gas to flow to the pilot light. Since some heating units are not equipped with relays, the pilot light is not automatically shut off in case of gas supply failure.

The electric switch-type relay shown in figure 2-37 is commonly referred to as a thermoelectric pilotstat. Its purpose is to break the circuit to the main gas control valve causing it to close or remain closed if the pilot

flame is out. It operates on current from a thermocouple located in the pilot flame. This current energizes the electromagnet in the relay which holds the contacts of the electrical switch in the closed position. In case the pilot light goes out, the current is no longer generated, and relay contacts will open and deenergize the main gas valve. The ON-OFF indicator shows the contact position of the snap switch at all times. The relay has a manual reset button. Pressing the button breaks the circuit. The snap switch is sealed and cannot make contact until the pilot burner is operating properly and the reset button released.

Exercises (418):

1. List the components of a gas burner fuel assembly.
2. Select statements that show the purpose of the individual component given by placing an X in the provided blank if the statement actually gives the purpose.
 - a. The manifold feeds gas to the spud.
 - b. The manifold houses the orifice.
 - c. The spud houses the orifice.
 - d. The manual shutoff valves regulates flow of gas to burner.

- e. The pressure regulator increases gas pressure.
- f. The pressure regulator maintains desired burner pressure.
- g. The thermocouple produces electrical current by means of heat.
- h. The thermocouple control relay serves as a safety device.

2-4. Operation and Maintenance of Gas Burners

Natural gas is an ideal fuel because it burns easily, requires comparatively simple equipment, and is clean. Therefore, operation of gas equipment is relatively simple, and minor maintenance procedures are normally all that is necessary in firing with gas.

419. List the main gas burner maintenance functions and some of the major operating fundamentals.

Operation. In operating equipment using gas burners, the total air flow needs to be controlled. This is done by adjusting the dampers or by changing the fan speed. Never use the burner air registers to control the volume of air. They are used strictly to control the shape of the flame.

Keep the gas-airflow ratio adjusted to obtain the minimum excess air with a zero CO in the flue gas. Maintain a correct furnace draft (normally about 0.10 inch of water-negative).

Since the gas supply to the furnace is regulated by the gas pressure, control the firing rate by changing the gas pressure or the number of burners in service to meet the demand. Maintain a slightly yellow flame at the pilot burners. This flame is stable and is not likely to be blown out when subjected to high draft. Maintain the main burner flame at a blue color with a yellow tip. It should be stable and not in contact with the burner tiles, ports, walls, or boiler tubes. Below are helpful hints in the operation of gas burners.

Directly or indirectly, the pilot light is usually the cause of most inoperative gas burners. Improper positioning of the thermocouple or thermopile and excessive flue and chimney draft conditions account for the greater share of faulty pilot light troubles. The pilot flame should be of sufficient length to heat the thermocouple and ignite the main burner without delay. It should be of a blue color, without a yellow tip. A yellow flame indicates improper combustion and forms

soot on the thermocouple insulating it from the heat of the pilot light. A thermocouple must be kept clean, and the proper amount of heat must be supplied to it, in order that it may produce a sufficient amount of electricity to operate either a pilotstat or gas valve. Excessive flue draft draws the pilot light flame away from the thermocouple. This condition causes improper heating of the thermocouple. Also, a short pilot light flame may not heat the thermocouple sufficiently for the thermocouple to produce a current.

If the thermocouple operates properly, then the trouble may be in the pilotstat or gas valve. These valves should be checked for poor electrical connections, as well as improper operation of the energizing electrical coils. In some cases, it is necessary to clean the valve seats, plungers, and plunger tubes in solenoid gas valves. Since these valves are expensive, extreme care should be taken to avoid damage to the internal mechanism. Check the main gas valve for open position. If the fuel supply is suspected, use a manometer to check the gas pressure, and the pressure regulator if necessary.

Maintenance. Gas burners should be inspected periodically to note the appearance of the gas flame. As stated previously, a yellow flame indicates a poor air-fuel mixture; it also indicates that carbon is being formed as the result of incomplete combustion. Such formations indicate poor flame adjustment. This carbon must be removed. Remember, if a good clean proper flame is not maintained the unit will become carboned and sooted, and a regularly complete cleaning will always be necessary.

Inspect and clean the orifice. Replace or repair any burned, damaged, worn, or defective part that could restrict the gas flow. Check the burner refractory material to see that there is no formation of carbon or soot deposits.

Maintaining a proper flame by an adequate air-fuel adjustment results in a good clean operation of a gas burner, thus preventing a continual strict maintenance schedule.

Exercises (419):

1. List the main functions performed on a gas burner maintenance schedule.
2. List some major operating fundamentals for gas burners.

CHAPTER 3

Warm-Air

YEARS AGO, fireplaces and pot-bellied stoves were the most common heating systems. With the rise in living standards and the advancement of technology, the heating systems of today are much more compatible to our need for comfort.

Because of being the least expensive and the simplest of all heating systems, warm-air heating is widely used throughout the Air Force. Warm-air heating systems provide space heating for buildings, base exchanges, warehouses, etc. by circulating warm air. This air is heated in an enclosure (furnace) and is carried through ducts, by gravity flow or by forced circulation.

3-1. Installation of Furnaces

As heating systems personnel, you will probably be more concerned with warm-air systems in domestic installations. Still, many large and fairly complex installations use warm air as a heating medium. In this section we will cover construction features and installation of warm air furnaces.

420. Name the basic construction components and materials of furnaces.

The warm-air system heats buildings by circulating warm air through all the areas that require heat. It is used to heat houses, base exchanges, administrative spaces, schools, chapels, warehouses, shops, and many other similar areas.

Heat Source. The heat source is a furnace unit which generates heat by burning fuel. Basically, a warm-air furnace consists of an ash pit or firepot, a feed or combustion chamber (primary heating surface), a radiator section or heat exchanger, (secondary heating surface), and a casing. The furnace may be cast iron, steel, or a combination of the two. It may be fired with any of the common fuels

and may be of the forced-air or gravity type. Gravity warm-air furnaces depend on convection currents to obtain the heat required to produce the air flow. Forced-air furnaces produce the necessary air flow with fans or blowers; they usually have air filters. Two typical warm-air furnaces are illustrated in figure 3-1 and 3-2. Figure 3-1 shows the basic components of an oil burner, and figure 3-2 shows the components of a typical gas furnace as used in the average home or individual dormitory.

Combustion chamber and radiator. The combustion chamber, as primary heating surface, absorbs heat from the fire, chiefly by radiation. The radiator section, as secondary heating surface, absorbs heat from the furnace gases by conduction.

Casing. The casing completely encloses the furnace assembly. It forms a space through which air is circulated (by natural or forced convection) and warmed by contact with the hot exterior surfaces of the combustion chamber and radiator. This warm air is carried by gravity through ducts to the various rooms, or forced by a fan that supplies all or part of the head (pressure) required to circulate the air against the resistances encountered.

Materials. Warm-air furnaces can be made of either cast iron or steel.

Cast iron furnaces. Generally, the minimum thickness of cast iron furnace sections is 1/2 inch. These furnaces resist corrosion and high temperature and, because of their relatively large mass, have a large heat-storage capacity. This latter characteristic gives them a fly wheel heating effect. However, they are slow to respond to heat changes.

Steel furnaces. The metal parts of steel furnaces are joined by riveting, welding, or both. Because of their relatively small mass, they can deliver heat rapidly on demand, and can adapt to fast changes in heat

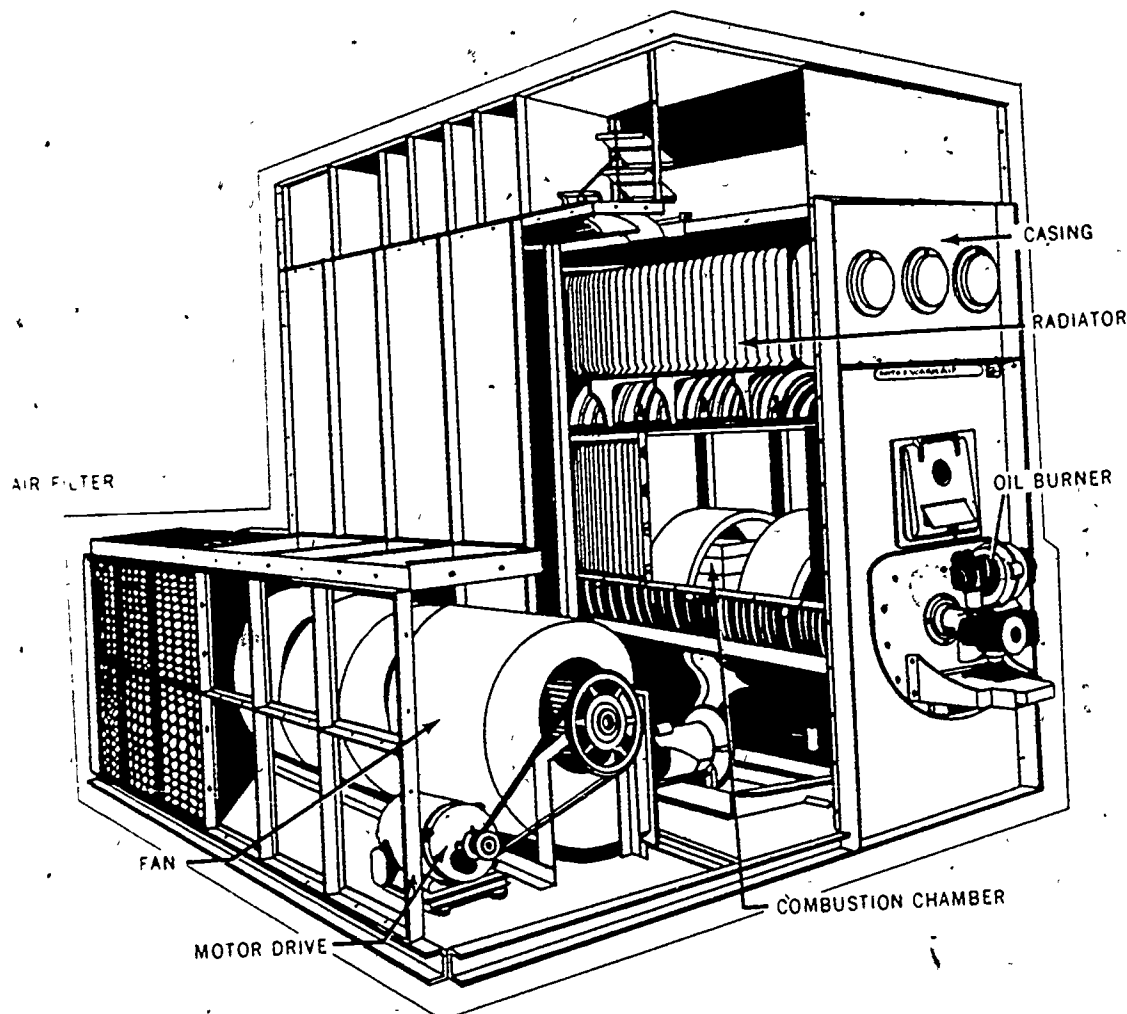


Figure 3-1. A typical forced warm-air oil burning furnace.

requirements. However, their heat storage capacity is rather small.

Coal-Fired Furnaces. Coal-fired furnaces are made of cast iron or steel. Cast iron furnaces are constructed in sections, made gas-tight by liberal use of furnace cement, asbestos rope, or both. The radiator (secondary heating surface) is usually located on top of the combustion chamber (primary heating surface). Steel furnaces are made of heavy-gage steel and are riveted and calked or welded at the joint to make them gas-tight. The fronts, which include the fire, ash pit, and draft doors, are usually cast iron. Small steel furnaces usually have a single radiator attached to the rear of the combustion chamber. In large sizes two radiators may be installed on the furnace sides.

Oil-Fired Furnaces. Oil-fired furnace designs are conducive to maximum oil

combustion because of their longer gas travel (which means adequate combustion-chamber volume) and their large heating surfaces. These furnaces are usually of the blow-through type, with an air-space pressure higher than the gas-space (combustion-chamber or flues) pressure. Compact fan-furnace-burner units designed to be installed in basements, closets, attics, etc. are available.

Gas-Fired Furnaces. Gas-fired, warm-air furnaces are direct-fired, that is, the heat is transferred directly from the hot combustion gases to the air that circulates around the furnace and radiator. There are two types of gas-fired furnaces, horizontal and vertical. Each consists of a gas burner, gas controls, fan (on forced-air types), filters, heat exchanger, casing, and sometimes a humidifier. Each furnace has a draft diverter, built into the furnace.

Exercises (420):

1. What materials are used to construct warm-air furnaces?
2. State the purpose of the casing on a warm-air furnace.
3. List the materials used to make a gas-tight seal on a coal-fired furnace.
4. Name the basic components of which a warm-air furnace is made.

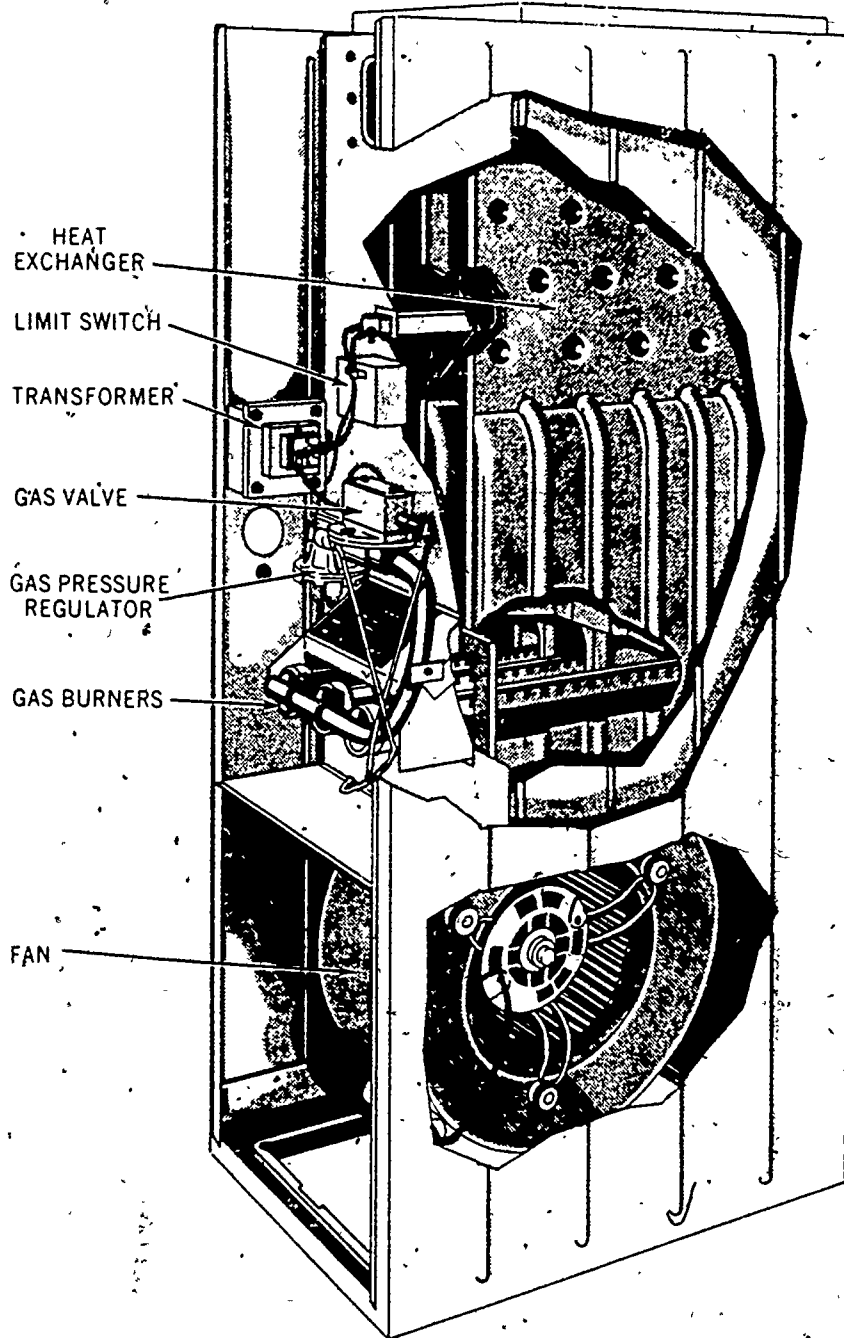


Figure 3-2. A typical forced warm-air gas furnace.

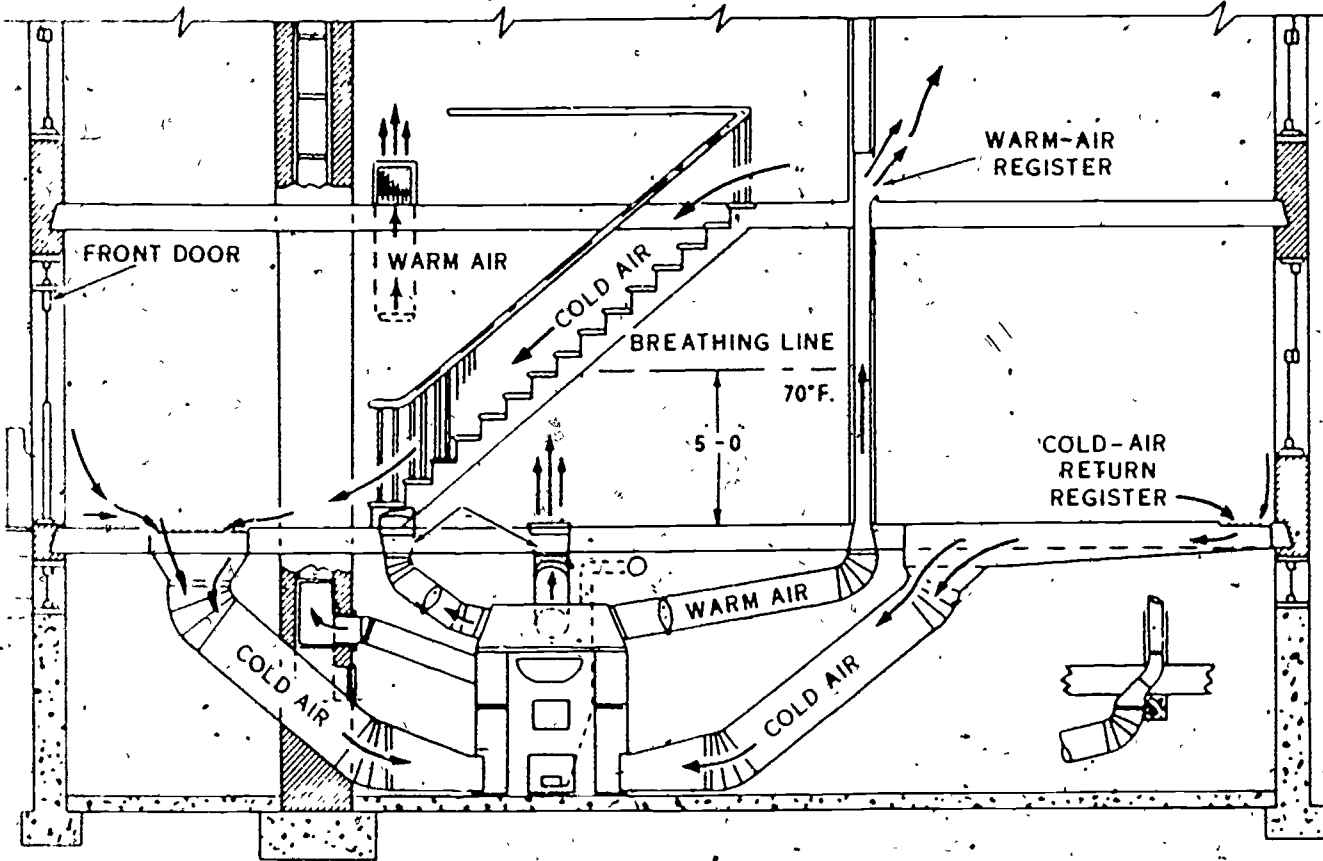


Figure 3-3. A typical gravity warm-air heating system.

421. Name and describe the various types of warm-air distribution systems, and from a list, differentiate between gravity and forced distribution systems.

Gravity. In the gravity warm-air system, natural convection causes circulation. The circulation takes place because of the difference in weight between warm air and cold air. Warm air is lighter than cold air and rises as cold air replaces it. A typical gravity warm-air heating system is illustrated in figure 3-3. Operating a gravity warm-air system depends on the size and location of the air ducts, the heat loss from the building, the heat from the furnace, and the temperature difference between the warm air and cold air. In the gravity system shown, the warm air registers are placed as close to the floor level as possible. This permits the warm air to rise

through the breathing line, which is approximately 5 feet from the floor at 70° fahrenheit, before returning through the cold air return registers. Notice that the cold air return registers are located near the outside walls. The most common cause of unsatisfactory operation is insufficient duct area, usually in the cold-air return ducts. The total cross-sectional area of all the cold-air ducts must be at least equal to the total cross-sectional area of all the warm-air ducts.

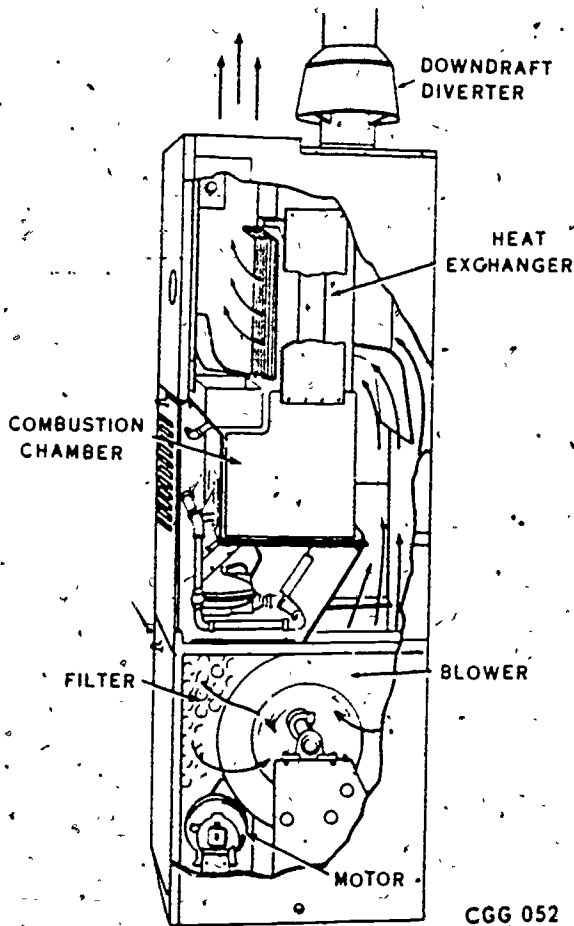
The furnace of the gravity warm-air heating system must be lower than the warm-air registers. The gravity furnace is usually in the basement. It needs at least 24 inches of clearance between the plenum (bonnet) and the ceiling. This minimum clearance allows ducts to be installed with at least 1 inch upward pitch per linear foot and leaves room for proper air circulation.

The gravity warm-air furnaces heat air that is later distributed through ducts to warm the individual rooms. As the air is heated in the furnace heat exchanger, it expands and becomes lighter than the cold air returning to the furnace. The warmed air rises and passes into the ducts connected to the top of the furnace. The ducts are usually sheetmetal pipes that rise continuously from the furnace to the warm-air registers from which the air is released into the space to be heated.

Forced. The function of a forced distribution system is to deliver the quantity of heated air required to maintain the desired temperature in any given space and to produce the desired quality of heating comfort by keeping the temperature differences between the floor and ceiling of each room and between the various rooms within the required limits. The location, size, and design of the supply grilles and registers in a distribution system has an important effect upon the results.

The fact that heat has to be added to a room indicates that an outward heat leakage is taking place. When the outside temperature is lower than the inside temperature, the heat loss occurs in different ways; through walls, windows, ceilings, and floors.

Basically, a forced warm-air heating system is similar to a gravity system. The main difference is that the forced system uses a centrifugal fan or blower (forced convection) instead of natural convection to attain positive air circulation. Figure 3-4 illustrates a typical forced-air furnace unit which provides the required air circulation head with a motor-driven blower. As shown in the illustration, air is drawn through the filter by



A typical gas-fired upflow forced warm-air furnace.

Figure 3-4. A typical gas-fired upflow warm-air furnace.

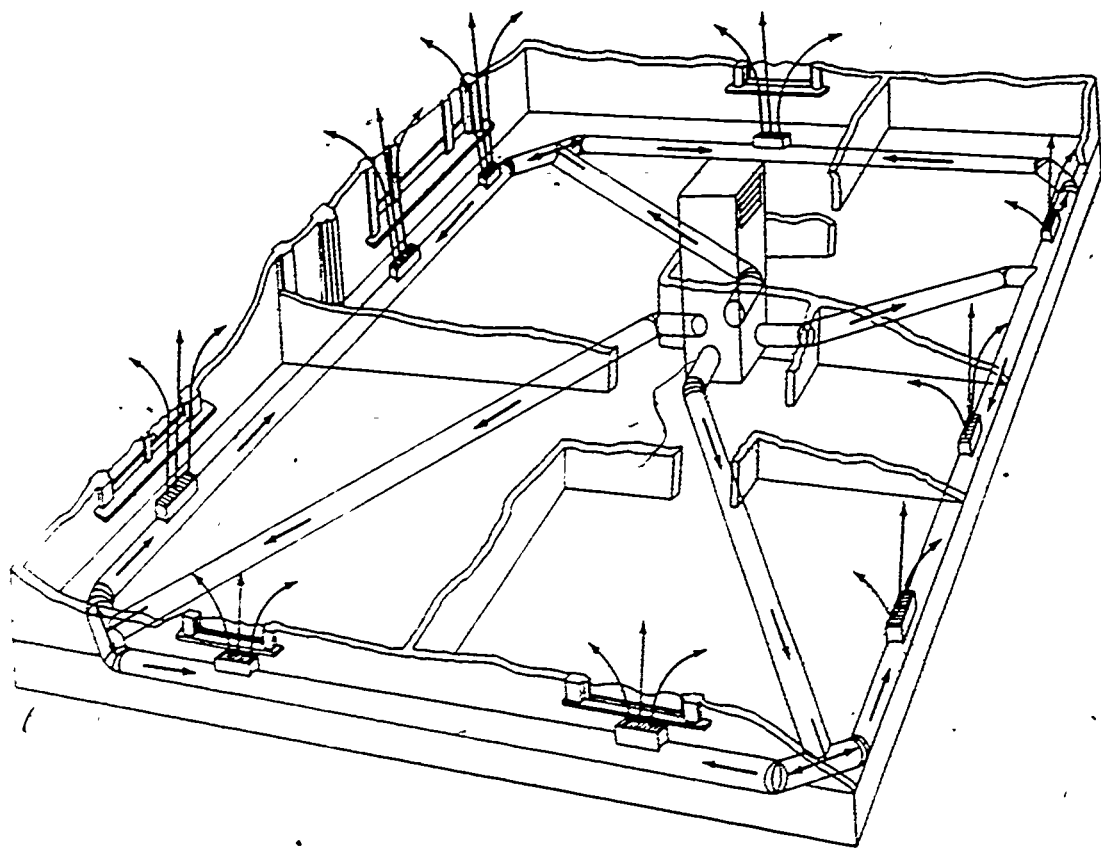


Figure 3-5 Perimeter loop.

the motor driven blower, and expelled upward through the heat exchanger. The gas fumes are expelled through the center cores of the heat exchanger and out the stack.

There are various types of air distribution systems to satisfy differing requirements. The systems with common characteristics are discussed below.

Perimeter Systems. These systems use supply openings around the outside wall areas, near the source of the greatest heat loss. They are equipped with registers designed to "blanket" the cold area. This type of location delivers the warm air so that it mixes with the cool air from the heat loss area and infiltration points, and prevents or reduces draft.

The air returns to the furnace through centrally located, high sidewall, or ceiling registers; the return ducts may be located in the attic or other unheated spaces. Be sure the duct size is adequate for its load since in the normal design only about one fourth of the total pressure at furnace outlet is available for return-air circulation. (That means 0.05 inches of water for a total pressure of 0.20 inches, when 0.15 inches of water are used on

the supply side.) Return-air can be taken from crawl spaces where the furnace is located. In perimeter system installations, a down-flow furnace is normally used. In these furnaces, cold air enters the unit from above and discharges as hot air from the bottom or lower part of the furnace casing. All perimeter distribution systems are similar in performance but differ in design. The design selected depends on building conditions. Let's look at the loop, the radial, the inside-wall delivery, and the ceiling delivery system.

Loop system. Figure 3-5 illustrates a perimeter loop system for use with concrete slab floors placed directly on the ground. A warm-air duct, with diffusers and grilles, extends completely around the perimeter of the building in a continuous loop that is supplied by radial feeder ducts from the plenum chamber. The ducts, buried in the slab, serve two purposes: they distribute warm air to the loop, and conduct heat that warms floors. As in other systems, warm-air registers are located and designed to prevent the air stream from discharging against people at rest. No more than three diffusers should be placed in a single section of loop duct between any two feeders.

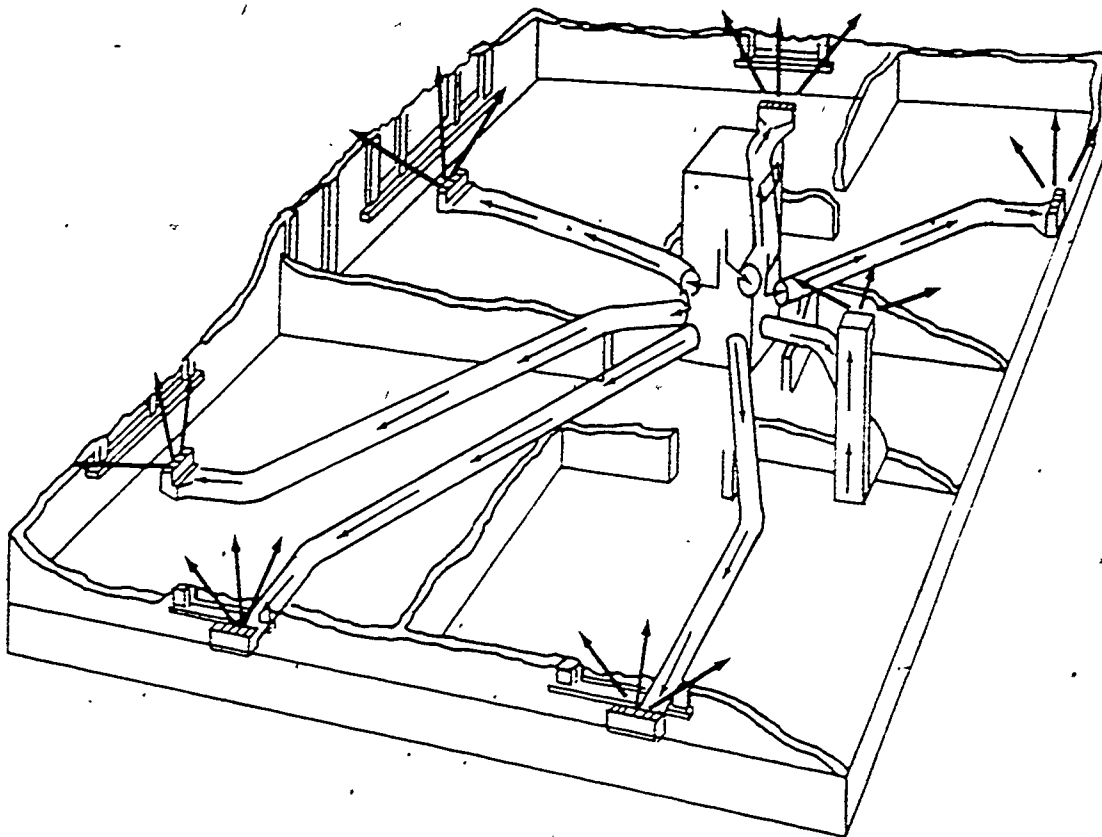


Figure 3-6. Perimeter radial system.

Radial system. Figure 3-6 illustrates a perimeter radial system. This air distribution system consists of individual ducts that run spokewise to each register from the plenum chamber of a more or less centrally located furnace. Normally, diffusers spread air uniformly over the register face. To reduce air velocity through the register, use registers with areas larger than the connecting ducts. Ducts can be run beneath the floor of structures with a basement or crawl space, or

embedded in concrete slabs if the building has no basement.

Crawl Space System. If a structure is built over a crawl space, the entire space can be used as a warm air supply plenum. Warm air enters the room through perimeter flow registers located preferably beneath the windows, additional heat is supplied by conduction from the warmed floors. This system is not recommended for Air Force use.

Inside-Wall Delivery System. Warm air

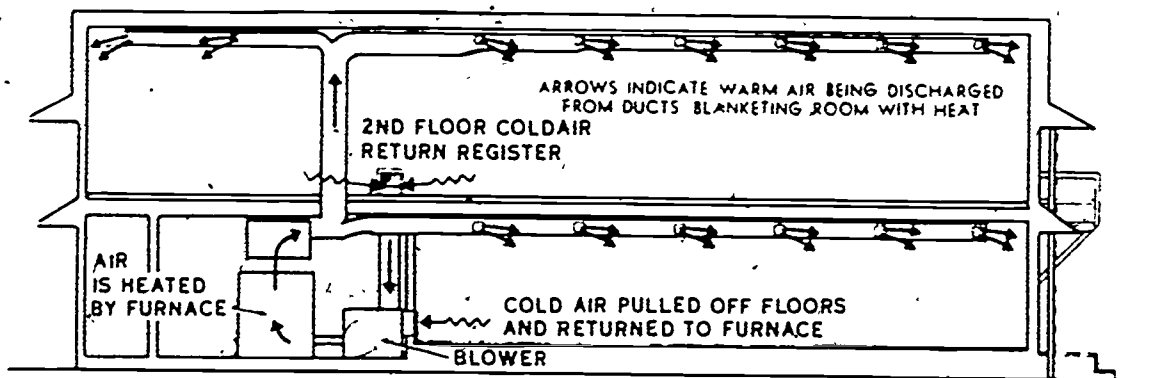


Figure 3-7. Layout of a ceiling delivery system.

perimeter heating is a relatively new concept. Older systems used different register locations to introduce the air into the heated spaces. One of these methods located the registers on an inside (warm) wall, with supply openings either high on the side wall, or near the floor, and return openings near the greatest outside exposure. High-side wall registers should deliver the air horizontally or slightly downward so that it does not strike the ceiling or wall. The air velocity at the end of the throw should be around 50 feet per minute; the throw, about 75 percent of the distance from the register to the opposite wall. (Throw or blow is the horizontal distance that the air stream travels after leaving the diffuser before its velocity drops to 50 feet per minute.) For best results, use directional flow diffusers that spread the air flow evenly over the register face. To reduce the outlet air velocity, use registers with an area larger than the connecting duct. Location of the warm-air return grille depends on the situation of supply outlets. Baseboard returns are preferable to floor grilles.

Ceiling Delivery System. The system uses ceiling diffusers to deliver the warm air to the heated space. With annular ceiling diffusers, the air stream is spread 360° and the rate of diffusion is high, however, the throw is low. Because of the short length of throw, high initial air velocities are often used. Figure 3-7 illustrates a typical ceiling delivery system.

Exercises (421):

1. Name the various types of warm-air distribution systems.
2. Describe the various types of distribution systems of warm-air.
3. From the following list insert an F for forced and a G for gravity to each applicable statement.
 - A. Furnace higher than registers _____.
 - B. Large bulky ducts _____.
 - C. A fan supplies circulation _____.
 - D. Furnace always lower than registers _____.
 - E. Uses registers with an area larger than the connecting duct. _____
 - F. Requires a minimum of 1 inch upward pitch per linear foot for the ducts. _____

284
422. From a list of statements select those that relate to fundamentals of installing a furnace.

Gravity Furnaces. Install gravity warm-air furnaces in accordance with the blueprints, diagrams, and other instructions furnished by the manufacturer with each furnace. Also be sure furnaces are installed so they comply with pertinent base directives. Because there are many types and makes of coal-, oil-, and gas-fired furnaces on the market, detailed assembly instructions to suit all of these makes and types are not published in this volume. However, the following paragraphs give you some general installation requirements that apply to all warm-air furnaces.

Read and study the assembly instructions that come with the furnace. Each piece of casting is manufactured to fit in its proper place. Parts of one type furnace are seldom interchangeable with parts of other types of furnaces.

The furnace must be level and on a solid masonry base. Do not install the furnace on a base constructed of wood or other combustible material. If the masonry base is uneven, level the furnace with steel or cast iron wedges (shims), or with the leveling bolts on the furnace. Always use a spirit level to make sure the unit is level.

There should be enough clearance for easy access for making repairs. Leave at least 18 inches between the furnace and a wall constructed of wood or other combustible material. To reduce the fire hazard, it is a good practice to install asbestos boards on a wooden wall next to a furnace. With masonry walls, the units may be installed nearer the walls; however, leave enough room to permit proper servicing. Give special attention to ceiling clearance. Cover the ceiling above the furnace with sheets of asbestos material when the top of the furnace is close to the ceiling.

Joints should be sealed with liberal amounts of furnace cement between the sections to insure that the furnace is gastight. Furnace cement is furnished with each cast iron furnace. Asbestos rope is also furnished with many furnaces for certain applications. Follow the manufacturer's instructions covering its use. See to it that projections from the furnace, such as smokepipes or cleanout doors, extend through the outside of the casing.

Carefully tighten the bolts. First, tighten each bolt until almost tight. Then, after you have installed all the bolts, gradually tighten

each until all are uniformly and properly tight. Drawing bolts too tight cracks or breaks a casing or buckles a steel plate.

When you assemble a furnace, check all doors for free operation and a tight fit. Air leaking around the doors reduces combustion efficiency. Check the grates in coal furnaces for free movement. To install firebrick, follow the manufacturer's instructions.

Install the furnace casing, bonnet, and gravity-return air shoe according to the manufacturer's instructions. Fasten the casings or panels securely. If they are interlocking, see that they are set properly in place and are airtight. If there is no bottom floor panel (gas or oil), grout the casing to make it airtight. Do this by chipping and wetting the floor and then using a liberal amount of cement mixture. If you use a circular casing, strip the joints with asbestos paper to make them airtight. Use asbestos rope or a draw-band collar to make the connection between the flue and the cleanout airtight. If baffles are furnished or recommended, install them in accordance with the manufacturer's recommendations. When installing baffles, take care to provide distribution of air over the combustion chamber and radiator. Before you install the baffles, check the heat exchanger for leaks and cracks.

Only the downdraft diverters that come with the equipment should be installed. Diverters are developed for individual furnaces, so you should never use diverters of local manufacture unless they have been calibrated for the specific heating unit. Downdraft diverters are built into the furnace or more commonly installed in the gas flue close to the furnace. These diverters prevent excessive chimney drafts from going through the furnace and affecting combustion or even extinguishing the flame. They also prevent downdrafts from reaching the flame and interfering with combustion. Air is taken into the flue through the diverter in the case of excessive draft, and expelled from the flue through the diverter in the case of a downdraft without ever getting into the combustion chamber.

Vents or smokepipes should be at least as large as the smokepipe outlets on furnaces. Install all horizontal smokepipes so that they have a pitch of not less than 1 inch per linear foot. Fasten a vent or smokepipe to the furnace with at least three sheet metal screws.

There should be a tight fitting cleanout for coal furnaces at the point where the smoke collar extends through the furnace casing. Usually the cleanouts for this location are

provided by the manufacturer. Install a checkdraft in the smokepipe, usually 18 to 36 inches from the smokepipe outlet of the furnace. Also, install the checkdraft with its hinges at the top of the pipe for easy lifting by a motor damper chain and for easy closing by the attached weight.

The furnace must have an adequate chimney. Good chimneys are built of steel, brick, or other material approved by the office of the Civil Engineer. Measure to insure that the chimney has a cross-sectional area equal to or larger than the flue outlet of the furnace being installed. The smaller dimension of a rectangular chimney must be at least two-thirds the furnace flue diameter. To be satisfactory above sea level, the area of the chimney must be increased 4 percent for each 1,000 feet of altitude above sea level. Make sure that the chimney is equipped with a soot and dirt cleanout at the base. The upper part of the chimney is often constructed of a metal section that terminates with an appropriate hood. Check to see that the chimney height at least meets manufacturer's recommendations. Even so, the chimney must never be less than 15 feet high, and always extend at least 3 feet above the peak of the roof.

The furnace room must be adequately ventilated to supply enough air for combustion. An opening having 1 square inch of free-air area must be provided for each 1,000 Btu per hour of furnace input rating with a minimum of 200 square inches. Whenever possible, locate the opening at or near the floorline. In addition, you should provide two louvered openings in the ceiling, one as close to each end of the furnace room as possible, to expel flue gases. These openings should have a free-air area of at least 200 square inches each.

Forced Air Furnaces. Install forced warm-air furnaces according to the procedures and diagrams issued by the manufacturer. Since the installation procedures for forced warm-air furnaces are similar to those for gravity furnaces, review briefly the general installation requirements for the gravity warm-air furnaces.

Most warm-air circulating blower units are built as part of the furnace by the manufacturer. You should bolt such units to a masonry base that is at least 3 inches thick and that extends at least 12 inches beyond the furnace casing. However, if the blower unit must be mounted separately, fasten the blower and blower motor to a masonry base in true alignment. Install the filters on the

inlet side of the casing so that all of the air is filtered before entering the fan.

The cabinet, housing the blower unit, should have doors so that you can easily oil, adjust, and repair the motor and blower, and replace the air filters. The complete unit must be reasonably well constructed to prevent air leakage.

Exercises (422):

The following are statements that may relate to fundamentals of furnace installation; select the related statements by placing an X in the blank provided.

- ___ 1. The furnace must be level and on a solid masonry base.
- ___ 2. There must be 36 inches clearance between the furnace and a combustible wall.
- ___ 3. Leave at least 18 inches clearance between combustible walls and the furnace.
- ___ 4. Smokepipes must *not* extend through the outside of the casing.
- ___ 5. Extend projections from the furnace through the outside of the casing.
- ___ 6. Grout the casing to make it airtight if there is no bottom floor panel.
- ___ 7. Use locally designed diverters to prevent downdraft.
- ___ 8. Install horizontal smokepipes with a pitch of at least 1 inch per linear foot.
- ___ 9. Install the smokepipe checkdraft device with the hinges at the top.
- ___ 10. Install forced system filters on the outlet side of the fan.
- ___ 11. Install filters on the inlet side of the fan.

423. Specify the requirements in the installation of ducts and dampers in a warm air system.

The air ducts of a warm-air gravity heating system carry the warm air from the furnace and cold air to the furnace. The air ducts are large, sheet-metal pipes constructed of lightweight galvanized metal to reduce weight to a minimum. The metal pipes are covered with a thin layer of asbestos paper to reduce heat loss through radiation.

Installing Air Ducts for Gravity Heating. Space warm-air ducts or leaders come from the furnace evenly around the bonnet of the unit for efficient heat distribution. A leader usually has a damper in the first length of

286

pipe attached to the bonnet. The warm air is taken from the casing hood or bonnet of the furnace through the leaders to the register box for the first floor. The warm air for the second floor flows through a vertical, rectangular wallstack, inside the wall partition, and also terminates at the register box. Install the register boxes either in the floor or the inside wall near the baseboard. The warm air is discharged through the warm-air registers, which are set in the register boxes. The registers usually have some type of shutoff mechanism. Leaders and fittings can be mass produced or fabricated specifically for each job. Use prefabricated leaders and fittings made of asbestos to reduce the danger of fire.

The air supply for the furnace is the cool air that comes from the area inside the heated building. The air is usually picked up before it spreads and causes objectionable drafts. The air is then conveyed to the base of the furnace through one or more cold-air ducts, also shown in figure 3-3. These ducts are sometimes referred to as cold-air returns, and they are usually much larger than the warm-air ducts. In some cases, where the ventilation requirements are high, some of the air is brought in from outside the building.

Air passages that form portions of cold-air returns can be included in the building plans, and you can construct them on the job from other materials. When you construct them, however, make the construction reasonably airtight. As a general rule, you should not equip the cold-air returns with dampers, since the cold-air returns are normally constructed in correct proportion to the warm-air ducts.

Almost every warm-air heating system requires adjustment and balancing of the airflow going to various outlets before the heat is evenly distributed. You can balance the heating system by adjusting the dampers in the duct branches while the furnace is in full operation. Continue balancing until the desired temperature is obtained in each room. You can also use a velometer or anemometer to balance the gravity warm-air system by following the manufacturer's instructions. If you ever need to furnish additional heat to some portion of a building at the end of a long duct, balance the butterfly valves in the other warm-air pipes to favor the deficient one. If this does not work, install a booster fan in the deficient duct to force the airstream. The air ducts for forced warm-air heating systems are usually rectangular in shape. However, you may use round ducts whenever they are necessary. With a positive-pressure blower, you may use smaller

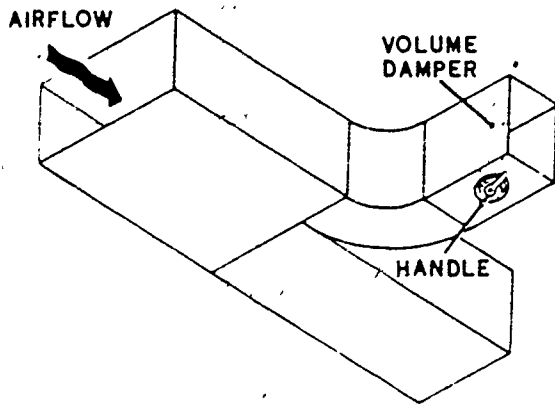


Figure 3-8. A diagram of a volume damper.

ducts and extend the system to heat larger areas without sloping the warm-air ducts. A forced warm-air duct layout for a two-story barracks is shown in figure 3-7.

Air ducts for forced warm-air heating systems, like the ducts for gravity warm-air systems, are constructed of sheet metal. They are normally constructed in the sheet metal shop in accordance with given specifications. The cross-sectional area of rectangular warm-air ducts is large at the furnace, but it gradually tapers at the end. Air ducts usually run from the furnace through partitions and along the ceilings of hallways and rooms. The cold-air return ducts for a forced warm-air heating system are rectangular and much larger than the warm-air ducts. They are usually short since the hallways of the buildings serve as a cold-air return. Both the warm-air and cold-air ducts are generally hung from the ceiling with metal strapping. When you install air ducts for forced warm-air heating, leave an air space between the ceiling and the ducts to reduce the possibilities of fire. Equip warm-air ducts for forced warm-air heating systems with dampers, shutoffs, and registers to control the flow of warm air. Figure 3-8 shows a diagram of a volume damper, and figure 3-9 shows a splitter damper. You must, of course, supplement these instructions by referring to the pertinent specifications and blueprints.

Exercises (423):

Specify heating duct connection requirements by answering the following:

1. In connecting a duct, what is usually installed in the first section of a leader coming from the plenum chamber?

2. What is one requirement in installing warm-air ducts and return-air ducts?
3. What requirement is necessary in the process of connecting ducts to insure proper control of warm air?
4. Which end of a rectangular duct connects with the furnace?

3-2. Maintenance of Furnaces

Always inspect and maintain forced warm-air furnaces in accordance with the manufacturer's recommendations, pertinent Air Force regulations, and local base directives to comply with the mandatory requirements and obtain efficient operation.

Both the gravity and forced warm-air furnaces require almost identical maintenance. This includes the inspection of furnace rooms for cleanliness, checking heat exchangers for warping and rusting to cleaning of stacks and chimneys of soot.

424. State the basic maintenance requirements of oil burner nozzles and gas burners.

Burners of the type commonly installed in warm-air furnaces were covered in Chapter 2 of this volume, however, we will cover a few maintenance fundamentals in this objective.

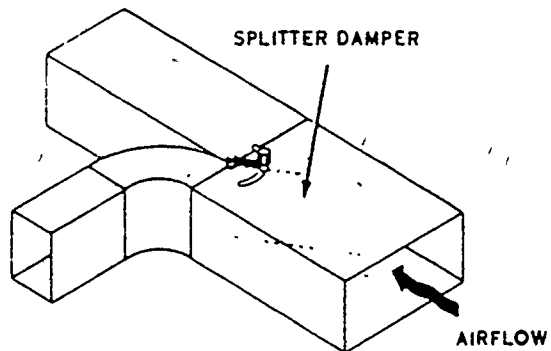


Figure 3-9. An air duct with a splitter damper.

Oil Burners. The heating specialist is responsible for the inspection and maintenance of oil burners. Unless a heating specialist has the proper tools, he cannot perform maintenance as required. Several items are a must for servicing gun-type burners, and they are listed as follows:

- A pressure gage set made up of 150-pound capacity pressure gage, the fittings to connect it, and the petcock used for purging air from the oil line when starting the burner.

- A full set of Allen wrenches for turning setscrews, bypass plugs, and for adjusting the nozzle holder and electrodes. Only a socket wrench of the proper size is used for the nozzle. An open-end S-wrench is required for nozzle holders.

- A small thermostat wrench is packed with some thermostats, and this is used for adjusting the differential.

- A small screwdriver is needed for adjusting pressure at the regulator, and for installing and servicing the thermostat.

- Be sure that the pipe dope used is for oil lines. If there is any doubt, order a can of special oil pipe dope and use it on all male pipe threads.

- A complete assortment of nozzles is needed. From the standpoint of time, it is cheaper to change a nozzle than to clean it on the job. After a few nozzles are accumulated, they should be cleaned in the shop.

Nozzles should only be cleaned on a clean work bench kept in the shop. The nozzle is a delicate device and should be handled with care. A safety solvent is used to cut away the grease and gum compressed air, if available, is used to blow out dirt. Goggles should be worn to protect the eyes when compressed air is used to remove dirt from the nozzle. Never use a metal needle to clean the orifice; sharpen the end of a match to use, or use a brush bristle for this purpose. Always use a socket wrench when turning a nozzle. Be sure that the nozzle seat is clean. When the nozzle comes to the "bottom," back it off and retighten it several times to make a tight oil seal. Do not tighten it too much or the brass threads will strip and make the removal of the nozzle difficult.

Gas burner systems require little maintenance. At least once a year, remove and clean the burner, pilot, and the thermocouple. Check the system for gas leaks by using a soapsuds solution. Adjust the primary air shutter of the burner if necessary. Tighten all wiring connections on the control units.

Exercises (424):

1. What is a basic requirement in the maintenance of oil burners?
2. In performing maintenance on a nozzle of a high-pressure gun-type oil burner, how is the orifice of the nozzle cleaned?
3. When you find an inoperative nozzle, what should you do?
4. What maintenance procedure would you perform on gas burner systems?

425. Explain the process for replacing oil or gas burners in a warm-air heating system and state the requirements of the replacement burner.

The process of replacing burners in warm-air furnaces is a relative simple task, depending of course on the type, size, and construction of the burner. For example, a high-pressure gun-type oil burner, as was discussed in Chapter 2, is constructed of all necessary components for the burning of fuel in a simple housing. Most housings are designed to be completely interchangeable; therefore when a component becomes inoperative, it is an easy task to change or replace that component. If it becomes necessary to replace the complete burner, the changeover can be accomplished by removing a few bolts and necessary wiring, thus the whole burner housing is disconnected from the furnace. Always consult the manufacturer and purchase the correct type and size oil burner. By replacing the bolts and wiring, making a few minor flame and air adjustments, the warm-air furnace is ready for operation.

In gas-fired furnaces, the gas burners are normally attached to the manifold by the orifice, spud, etc. (This was covered in Chapter 2.) Each burner section normally lifts out of the combustion area and another can be inserted without the removal of any bolts, screws, etc.

The most important requirement necessary

in replacing any type burner in a warm-air furnace is to make sure the correct burner is being used as the replacement. Always consult the manufacturer's brochures for this information.

Exercises (425):

1. Explain the process for changing an oil burner of a warm-air furnace.
2. What is the most important requirement in the replacement of a burner?
3. Explain the process of replacing a gas burner.

426. Name the types of fans (blower units). State the blade positions, where they are used, and how they are driven.

Fans are used to circulate air in ducts of the forced warm-air system. They are normally of the radial flow type, commonly called centrifugal or squirrel-cage fan. The squirrel-cage fan blades are a multiblade fan with the blades in the following positions. The blades are curved backwards, forward, or plain radial. The tip of the forward curved blade inclines in the direction of rotation, while the radial blade is straight, and the top of the backward curved blade inclines in a direction opposite of the rotation.

The most commonly used blade is the forward curved one. It operates at a relatively low-tip speed for a given pressure. It is compact in size and quiet in operation. The radial blade is used for overage speed rotation, and the backward curved blade is used for relatively high-speed operation.

The blower units, no matter which type fan blade they use, fall into two categories—direct-drive or belt-drive type. Small fans, especially those operated at high speeds normally use the direct-drive, or are directly connected to the motor shaft. Large fans and those that normally operate at lower speeds use the belt-drive or are connected to the motors through pulleys. You should select a motor one size larger than is required for

normal load conditions. This precaution will all allow for larger volumes of air that may be required.

Exercises (426):

1. What are radial type fans commonly called?
2. What is the position of the blades of a multiblade fan?
3. What type of blade is used for high-speed operation?
4. Name the two categories of blower unit (fans).

427. Cite the types of bearings, and from a given list, match the maintenance requirements or actions to the motors and bearings.

Bearings are described as machine parts in which a journal, pin, or other part turns. Bearings found in heating use are classified under the following headings.

Antifriction Bearings. Ball and roller bearings are the two most commonly used types of antifriction bearings. The ball bearing consists of an outer ring or race, the balls, and the inner race. The balls roll in grooves in the races. Roller bearings are essentially the same as ball bearings except they contain rollers instead of balls. Races, balls, and rollers are very hard and are made with highly polished surfaces that must be properly lubricated. Either oil or grease may be used to lubricate these bearings. When grease is used, too much lubricant may cause the bearing to over heat and be damaged.

Sleeve Bearings. Sleeve bearings may be made of bronze, brass, babbitt, or cast iron. Some are bushings that are slipped over the end of the shaft, and others may be split and supported in a housing. These bearings may be lubricated with oil or grease. Oil lubricated bearings may be oiled any of several methods such as forced feed, ring feed, drip feed, or saturated wick.

Thrust Bearings. Thrust bearings are designed to carry loads applied along a shaft. They may be simple thrust collars or elaborate thrust bearings. They may be ball, roller or sleeve. The care required is the same as for comparable types of ordinary bearings.

Bearing Installation. When a bearing is installed, the bore should be lightly coated with clean oil that floats away any particles of dust or dirt. The bearing area of the shaft should be lightly oiled, then wiped clean. Before the collar is adjusted to its final position (see fig. 3-10) the shaft should be tapped lightly with a rubber hammer, and rotated a few times to allow the bearings to align themselves properly. The shaft will, thus, establish its normal "float" or operating position.

After the proper alignment of bearing and the correct float of the shaft has been determined, adjust the collar and leather washer to permit a minimum clearance of approximately 1/32 inch between the face of the bearing, the collar, and the washer. Lock the safety collar in this position by tightening the set-screw. Fill the oil cup with the proper type of oil and the bearing is ready for use.

Bearing Adjustment. Some belt-driven blowers have bearings that are self-aligning. Others have bearings that are held in place by bolts that stabilize the bearings to the blower housing. If the bearings are binding, loosen the bolts and let the bearings come into alignment before tightening them.

The thrust collars are locked to the shaft on the lock side of the bearings. Between these and the end of the bearings is a leather washer. These collars keep the shaft from sliding out of the bearings, and when properly adjusted, prevent end play. If you hear a thumping noise in the blower, it is because of too much end play. Adjust the collars and the noise will disappear. The collars should be adjusted as close to the sides of the bearing as possible without binding against the bearing. After every adjustment, remove the blower belt and spin the blower by hand in order to make sure it rolls freely.

Motor Maintenance. Most blower motor trouble and noise is caused from lack of oil. Motors on belt-driven fans have bearings that require lubrication at the time of installation and at least every 6 months thereafter. Lubricate fan motors with a good grade of engine oil. CAUTION: Do not over fill and do not use a detergent oil. If the internal parts of the fan motor become coated with dirt and lint, a good jet of air blown through the motor will usually provide a satisfactory cleaning.

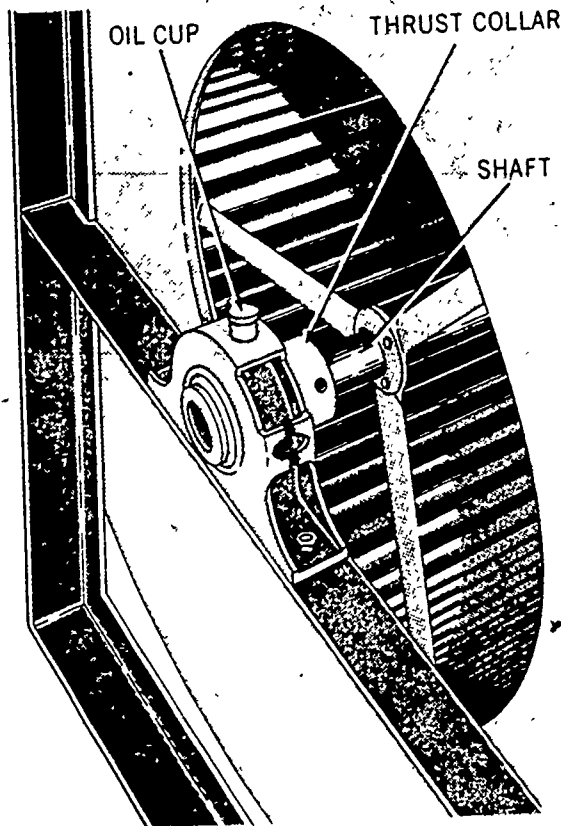


Figure 3-10. Loose thrust collar.

Since direct-drive fan motors do not require oiling, check oiling instructions mounted on the furnace to determine if oiling is necessary or not.

Exercises (427):

1. Cite the types of bearings commonly used in heating equipment.
2. Match the maintenance requirements listed in column B to the motor or bearing in column A by writing the correct letter in the blank provided.

Column A

- 1. Sleeve bearings
- 2. Antifriction bearings.
- 3. Blower motor.
- 4. Damaged bearings.
- 5. Thrust bearings.

Column B

- a. Either grease or oil is required for lubrication.
- b. Lubricate with forced-feed oil, ring oil, or drop-feed oil.
- c. A properly designed oil groove is required.
- d. Lubricate with a good grade of SAE oil.
- e. Clean by using a jet of air.

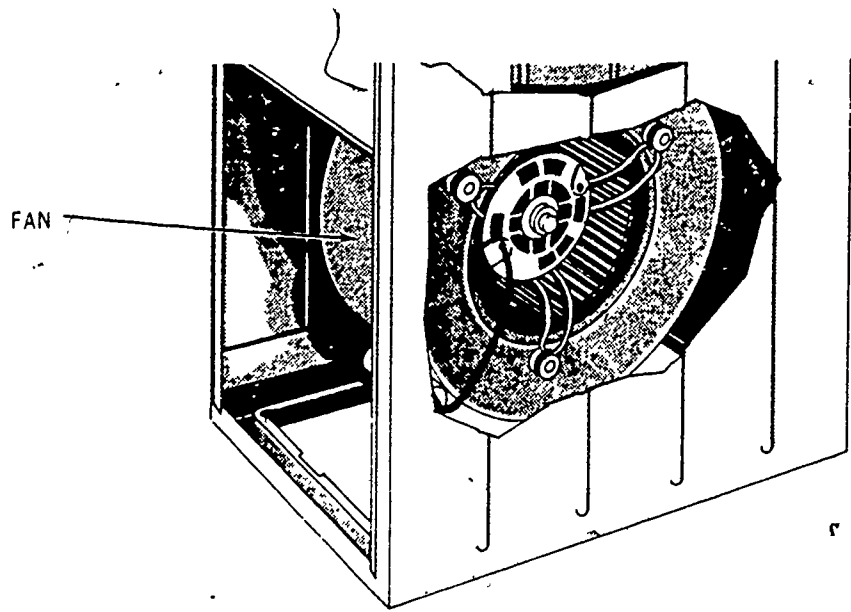


Figure 3-11. Direct-drive blower assembly.

Column B

- f. Too much lubricant.
- g. Bushings are split and supported in a housing.
- h. Designed to carry loads applied along a shaft.

428. Specify the cause for removing and replacing fans in warm-air furnaces and explain how to do it.

At periodic intervals the complete blower assembly should be inspected for cleanliness, vibration, overheating, noise, etc. Most blower troubles will be caused by the motor, bearings, belts or improper alignment, and not by the fan itself.

Most blower assemblies of the direct-drive fan, such as shown in figure 3-11, are fitted into a groove that is built into the furnace casing. The blower assembly is held stabilized by various bolts.

The removal of these bolts and disconnecting of the motor wires permits the complete blower cage to be removed from the furnace. The motor can then be disconnected and replaced, and the fan cleaned or replaced.

In belt-driven blower assemblies, as shown in figure 3-12, the motor is separate from the blower cage. The cage is normally attached to the frame of the furnace in much the same way as the direct-drive fans. In removal, the belt is first to be removed, the various bolts that hold the cage to the frame are removed, and the blower assembly can be separated from the furnace. The fans can then be repaired, cleaned, or replaced. After the blower assembly is reconnected to the furnace and the fan belt replaced the furnace is ready for operation.

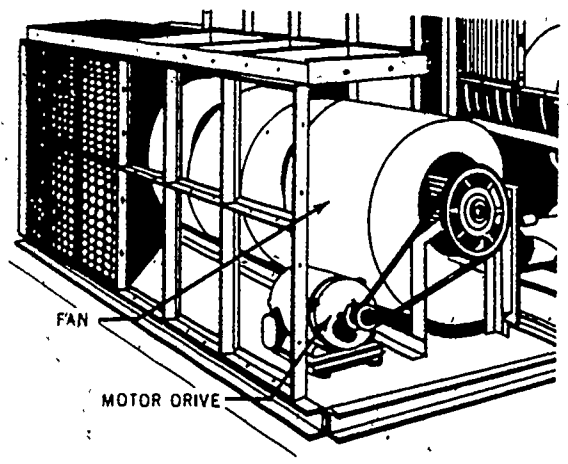


Figure 3-12. Belt-driven blower assembly.

Exercises (428):

1. What would cause a blower assembly to be removed and replaced?
2. Explain how to remove and replace a fan from a warm-air furnace.

294

429. Name the types of couplings, pulleys, and drive belts and describe the maintenance requirements for aligning, adjusting, inspecting, or replacing each.

Couplings. Flexible couplings connect the shafts of the driver and the driven equipment. They are necessary because flexibility of the base, unequal wear of the bearings, and differences of temperature make it difficult to maintain perfect alignment between the two pieces of equipment at all times. Flexible couplings should not be confused with universal joints. The equipment should be kept in good alignment and the couplings should not be expected to compensate for gross errors in this respect. The rubber-bushed coupling is commonly used. It consists of two flanges, a number of coupling bolts, and the coupling rubbers. The rubbers are cylindrical in shape, and fit into holes in one flange. The coupling bolt is made with a shoulder, and slips through the hole in the rubber bushing. The shoulder is pulled up tightly against the face of the other flange. The rubber is resilient and permits slight flexing. Another common type of coupling utilizes gear teeth. This coupling consists of two inner parts with external gear teeth and two outer parts with matching internal gear teeth. The outer sections slip over the inner sections and bolt together. This coupling is partially filled with oil to lubricate the gear teeth. Both types of couplings require attention. Rubber bushings deteriorate, lose their resiliency and shape, and the bolts wear and become loose. The gear type requires frequent cleaning and lubrication.

Pulleys. A pulley is a wheel used to transmit power by means of a band, belt, cord, rope, or chain. Figure 3-13 illustrates the two most common types of pulleys. The larger pulley, or mill pulley as it's referred to, is normally attached to the fan shaft. These pulleys come in various sizes, and are usually selected on the basis of speed and load applications. The smaller pulleys, or sheaves, are connected to the motor shaft. Most of these pulleys are adjustable. Figure 3-13 illustrates a variable speed sheave pulley.

Drive Belts. Belt drives are often used when it is unnecessary to maintain an exact speed ratio. They also help cushion the equipment against shock and impacts. Two popular types are the V-belt and the flat belt.

The V-belt is widely used for all types of machinery. The belts are made of cotton cord

or fabric impregnated with rubber, and are available in a variety of sizes.

The flat belts are usually made of leather, plain and impregnated cotton, rubber, or canvas. Flat belts also come in a variety of sizes and come in single, double, or triple layers.

Maintenance. The following maintenance applications will be performed periodically to insure the desired temperatures are maintained in warm air systems.

Blower speed adjustment. Centrifugal fan units operate under a wide range of speeds. However, you will find that the exact speed of a specific fan unit depends on the design of the system in which the fan is installed. The proper speed ratio between the blower and the motor is obtained by using sheaves with different diameters on the blower and the motor. Also, to permit minor speed ratio changes, the motor sheave is usually adjustable, as was shown in figure 3-13. Multigroove sheaves are also used where more than one belt is needed.

When you change the drive ratio, first determine that the motor is not overloaded. Before you bring the sheave flanges closer together to make the sheave pitch diameter larger, take an ammeter reading with the motor under full-load operating conditions. Then compare the ammeter reading with the full-load amperage stamped on the data plate. When you make a sheave change, do not bring the flanges so close together that the belt rides above the flanges. Nor should you separate them so widely that the belt rides below the vee of the flanges. Either condition will cause rapid wear of the belt.

To adjust the sheave (refer to fig. 3-13), first loosen the setscrew on the movable flange and screw the flange in or out as desired. Then, after you make the proper adjustment, position the movable flange so

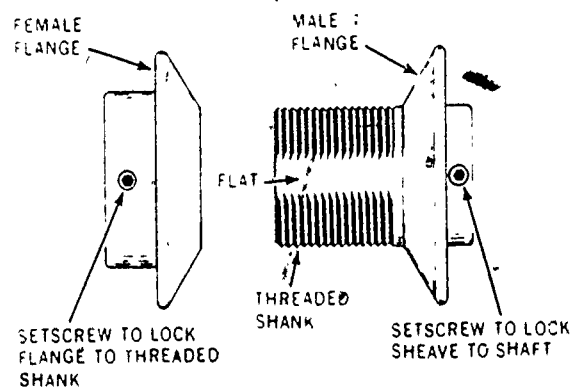


Figure 3-13. Variable pitch sheave.

that the setscrew rests on the flat side of the hub, and tighten the setscrew. Last, you realign the sheaves on the motor and the blower, and check the belt tension.

Belt replacement and adjustment. Since a new belt is somewhat shorter in length than an old stretched belt, you must not force it on the sheaves. To make sure you don't force it, loosen the motor on its base and shift it closer to the blower. Then place the belt on the motor and blower sheaves, adjust, and again tighten the motor to its base. The belt must fit completely in the vee of both sheaves; otherwise, you will have rapid wear, noise, and slipping.

Always remember to replace multiple belt drives with matched sets. A new belt cannot be adjusted for proper tension when installed with old stretched belts, since the shorter new belt would carry most of the load and soon wear out.

To adjust belt tension, slide the motor on its base until the belt is snug, then tighten the motor mount bolts. You will find that a good method for checking proper tension is to strike the belt with your hand. If the belt is properly adjusted, it will vibrate; a slack belt will feel dead and will not vibrate. Be careful that you tighten belts no more than necessary to prevent slippage. Refer to figure 3-14, which shows the play in the belt necessary for proper belt tension. A belt that is too tight causes an extra load on the motor and may damage the motor and blower bearings.

Sheave alignment. Check the motor and blower sheave alignment each time that a belt is replaced, sheaves are adjusted, or the motor is loosened on its mount. You check sheave alignment by using a straightedge or tight line.

The motor shaft is usually long enough so that the sheave can be adjusted to line up with the blower sheave. However, if you cannot make the alignment adjustment by this method, you must readjust the motor on its mount. Improper alignment of sheaves shortens the life of belts and also causes excessive wear on the faces of the sheave flanges.

Exercises (429):

1. What are the most common types of pulleys used in the heating field?
2. What types of drive belts are used?
3. What are two types of couplings normally used?
4. Describe the operation you perform on a motor sheave to change the drive ratio.
5. What is the process for replacing a drive belt?

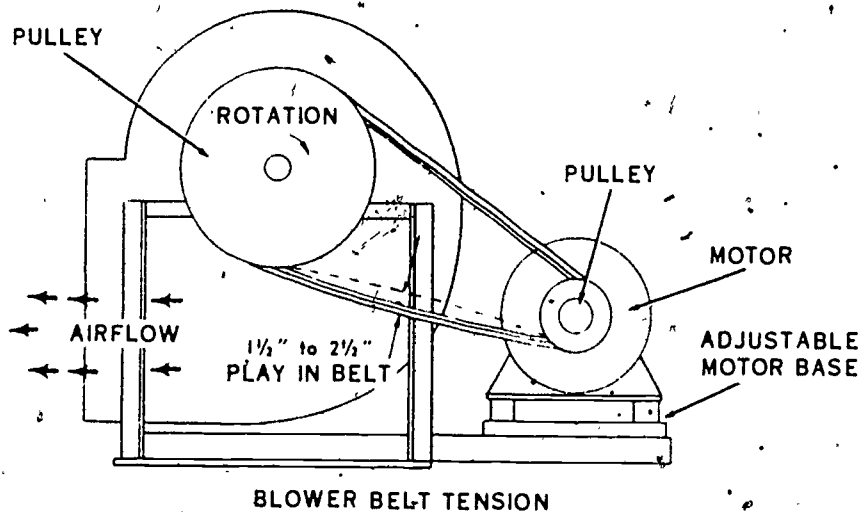


Figure 3-14. Blower fan belt adjustment.

6. If you find a worn and frayed drive belt being used on a multigroove sheave, what should you do?

7. What maintenance requirements are necessary in using gear type couplings?

430. Name the types of air filters, state when they should be cleaned or replaced, and list the materials used to clean reusable filters.

Air filters are used to remove atmospheric dust from the incoming cool air. They are usually installed in return-air chambers before the blower. For the best results, never expose air filters to temperatures above 150° F. The performance of air filters is determined by the following factors.

Face Velocity. The average velocity of air entering the effective face area of the filter is called the face velocity. The effective face area is the total area within the filter frame, including any that is occupied by bracing or grid members.

Resistance to Airflow. The resistance of a filter to airflow is usually measured as the pressure drop caused by the filter, expressed in inches of water (1 inch of water equals 0.03613 psi). The pressure drop of a given filter depends on its cleanliness and the volume of air flow. As air flow increases or the filter becomes loaded with dust, the pressure drop through the filter increases. Filter resistance increases rapidly as dust accumulates and may cause a substantial reduction in airflow, in inches of water (pressure drop).

Filter Efficiency. The measure of an air filter's efficiency is its capacity to remove dust from the entering air. Expressed as a percentage, the efficiency is given by:

$$E = \frac{W_1 - W_2}{W_1} \times 100$$

when

E = filter efficiency (percent)
W₁ = weight of dust per unit volume of unfiltered air.
W₂ = weight of dust per unit volume of filtered air

294

When air filters are used, they must be inspected at least once each month and cleaned or replaced whenever necessary. Dirty filters reduce airflow, impair heating performance, and increase fuel consumption.

Filters are of two types: cleanable and throwaway. Both are considered as viscous filters. These viscous filters consist of a porous layer of coarse material coated with a viscous substance, such as oil. The filtering material may be steel, wool, wire screen, animal hair, hemp fibers, glass fibers, or similar material. The oil substance is odorless and nonflammable. Air passes through the filter and makes several changes of direction as it flows through. This causes the dirt and dust particles present in the air to pass over the surfaces of the filtering material and be entrapped by the viscous fluid. As dirt is collected on the oil covered surfaces, the resistance of the filter to the passage of air is increased, thereby requiring periodic removal and cleaning of the filter. Usually filters should be cleaned or renewed at least every month during the heating season.

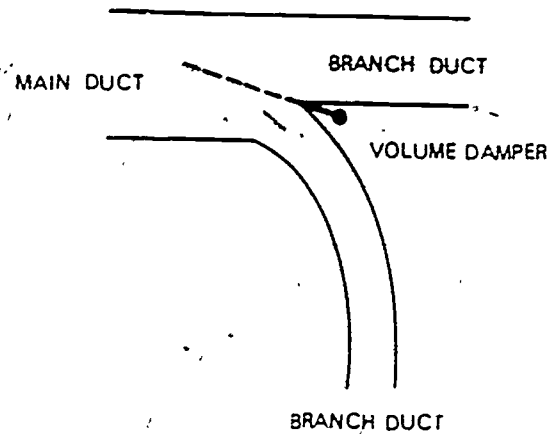
The throwaway type viscous filters should be discarded when they become dirty and should be replaced with entire new units. Cleanable filters, or permanent filters, are designed to be cleaned and used repeatedly. When they become dirty, they should be removed from the ventilating system and cleaned. The cleaning may be accomplished by using hot water or steam, or by a solution that will cut and remove oil. After these filters are washed and dried, they should then be recoated with the oil substance. Follow the manufacturer's recommendations regarding the type and amount of oil to be used. Special filter cleaning equipment such as washers and oilers are employed by some bases.

Exercises (430):

1. Name the two types of filters.
2. How often should filters be cleaned or renewed?
3. How are reusable filters usually cleaned?
4. What operation is accomplished after a reusable filter is cleaned before it can be reused?

3-3. Inspection and Maintenance of Air Distribution System

Ducts are used to distribute air to conditioned rooms or spaces, and to remove or exhaust air from rooms. Heat ducts are usually constructed from sheets of aluminum or galvanized steel. Ducts may either be round or rectangular in cross section. Straight sections of round duct are usually formed from sheets rolled to the proper radius and assembled with a longitudinal grooved seam. Each end of a round section is swaged and assembled with the larger end of the adjoining section butting against the swage. The sections are held together by rivets, sheetmetal screws, or by soldering. Rectangular ducts are generally constructed by breaking the corners and grooving the longitudinal seam.



CGC 024

Figure 3-15. Volume damper

431. List duct system discrepancy inspection items and tell how to remove foreign material from the duct.

Construct duct systems to avoid abrupt changes in size and direction and other resistance conditions which create noise and reduce air volume. Use interior vanes at elbows, and streamline obstructions.

The interior of ducts may be lined with sound-absorbing material to reduce noise caused by air passing through the ducts. It is usually more convenient to line all four sides of the duct interior, but a lining on one side over a longer length of the duct will, in general, give the same effect for the same area of applied sound-absorbing material. The exterior of ducts that carry conditioned air may be covered with an insulating material to prevent heat transfer between the ducts and the surrounding air.

Ducts should be constructed to enable them to be maintained easily. Provide access doors in the ducts to facilitate easy cleaning and inspection.

Periodic Maintenance: Inspect ducts periodically for the following conditions: deformation; leakage losses caused by loose clean-out doors, broken joints, holes worn in ducts (most frequently in elbows), and poor connections to fans; and accumulations of material, such as dirt, lint, and condensation of oil or water vapor, on the interior of the ducts. Repair or replace defective ducts or duct connections. Remove accumulations of foreign matter on the interior of the ducts by washing or vacuum cleaning. If applicable,

inspect sound-absorbing and insulating material on the interior of the ducts to determine that the materials are installed securely and adequately. Inspect duct hangers and supports to insure that the ducts are supported substantially.

Yearly Maintenance. Clean ducts annually. Protective paints may be applied to air ducts if necessary to protect them from corrosion. One of the most effective protective coatings is red lead paint. Apply three coats of paint for protective purposes; the first coat of a rust inhibitive type paint, such as red lead paint; the second coat a rust inhibitive tinted to a light brown color with carbon black; and the finish coat may be red lead print tinted to a black or brown color, black paint, a red iron oxide paint, or white or light-tinted paint. A chlorinated rubber-base paint may be used for the finish coat, particularly where the presence of highly corrosive gases would injure standard paints.

Exercises (421):

1. What discrepancies are ducts inspected for periodically?
2. How are accumulations of dirt and foreign material removed from ducts?

301

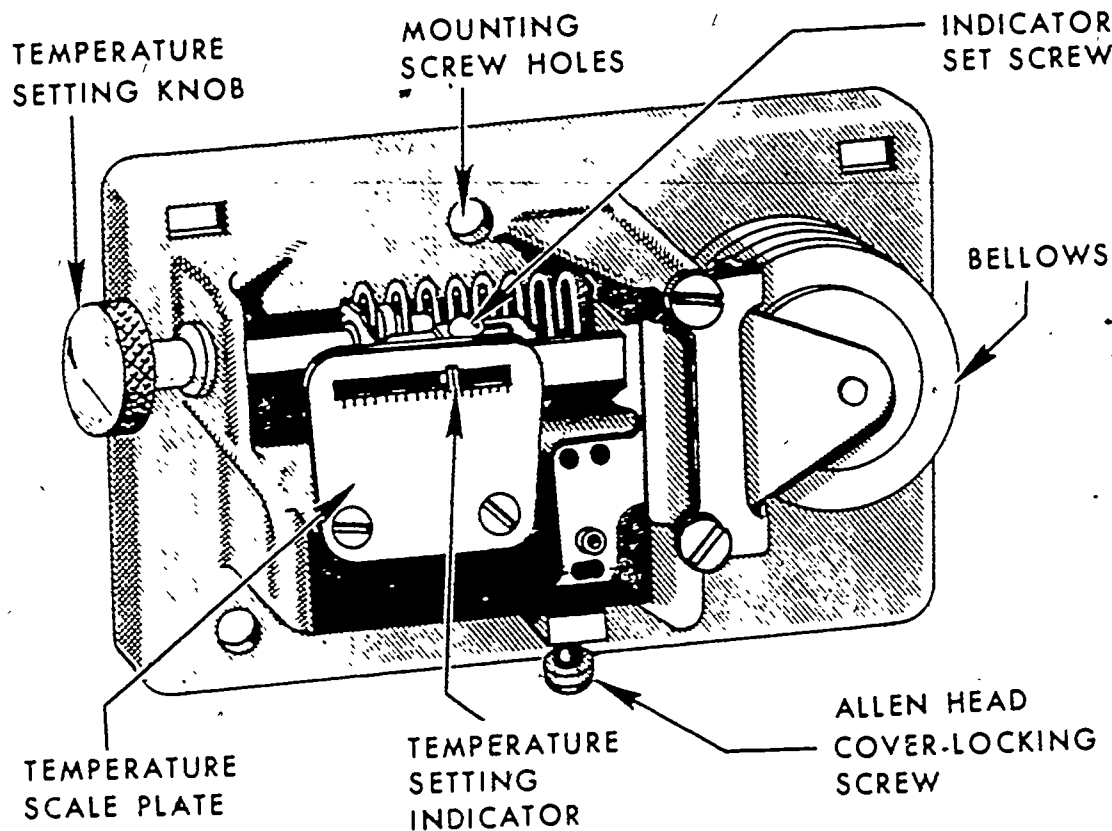


Figure 3-16 A bellows-type thermostat.

432. Indicate the types of dampers to be inspected and probable causes warranting adjustment of dampers and linkages.

Dampers of the following types are usually installed in heating and air-conditioning systems: face and bypass damper, air intake damper, volume damper, and recirculating damper.

Face and bypass dampers regulate the airflow around or through heating and cooling coils or the air is diverted in specific directions to avoid airflow through a certain duct area. The volume damper is installed in the interior of the duct, as shown in figure 3-15. It provides a division for air volume to the openings by changing the area of the passageway. The volume damper is generally constructed of one blade and is fastened to the side of the duct with indicating sections on the exterior side of the duct surface for adjustments. This is the most common damper used in heating warm-air systems.

Intake dampers are installed in the air intake to the heating or air-conditioning equipment. These dampers usually regulate

the fresh air intake to the spaces served by the equipment. The recirculation damper and exhaust damper are usually connected to a common motor by linkage. The linkage is arranged so that when one damper is open, the other damper is closed. Usually they can be at any position, from fully open to fully closed.

Dampers are installed in numerous ways to regulate and control air movement. They may have either one or several blades and may have automatic or manual controls.

Operation. All dampers operate either manually or through the use of automatic controls. Automatically controlled dampers are generally used in large heating and air-conditioning systems and are operated by a motor. The motor operates pneumatically or electrically, and moves the dampers to various positions. The size, material, methods of operation, leverage, location, and designs of the motor vary with the manufacturer's specifications and installation requirements.

Manual damper control is done through the use of rope or cable extensions. They are generally used for intake, exhaust, or volume dampers.

Maintenance. A few defects that might occur in the operation of a damper follow:

- a. Bent shafts.
- b. Binding of blades or operating mechanism.
- c. Bent rods or levers.
- d. Air leakage.

The most common defect that causes erratic damper operation is binding blades.

Wherever possible, you must inspect damper operation; and if any of the above defects are found, immediate action must be taken to repair the unit.

Most large dampers are built as a single unit and constructed with a frame to fit the duct and chamber opening. If the unit needs to be replaced, the complete damper unit can be taken out and a new damper installed. Whenever the services of a sheet metal worker are needed, the civil engineering section should be notified according to local procedures. You should refer to construction drawings and specifications for location of dampers and installation details.

Exercises (432):

1. Indicate types of heating systems dampers that would require inspection.
2. Indicate probable causes or defects that may necessitate adjustment of dampers and linkages.

3-4. Heater Controls

Various controls are used in heating systems for automatic control of temperature and humidity. Once the controls are installed and adjusted, they need little further attention. Most of the controls were covered previously, however, we will cover the controls essential to warm-air heating systems.

433. State the principle of operation and the condition controlled by various heating system controls and match heating system locations to a list of heating system controls.

Description of Controls. There are various controls used on warm-air heating systems such as the thermostat, limit control, fan switch combination control and a humidifier control.

Thermostat. The thermostat is the "nerve center" for a heating system. It is a sensitive unit that responds to changes in temperature. It indicates when heat is needed from the heating system. The thermostat transmits an electrical signal to other control devices by making or breaking electrical contacts within the thermostat itself.

Thermostats differ somewhat in construction. There are two types: the bimetallic spring and the bellows types. The bimetallic spring type is constructed of two dissimilar metals bonded together. One contact of a set of contact points is connected to the bimetallic spring. Then, as temperature changes occur, the dissimilar metals expand or contract at different rates bending the bimetallic spring, which causes the contact

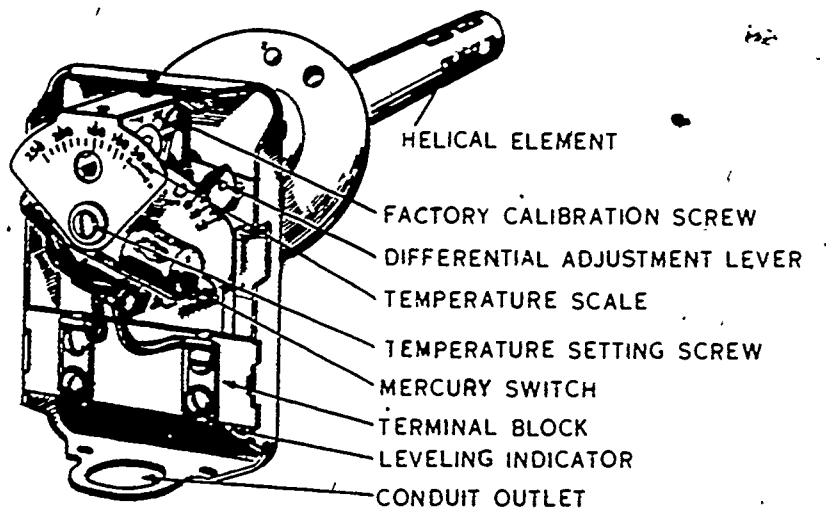


Figure 3-17. Diagram of a fan switch.

point to open or close. The bellows-type thermostat, figure 3-16, is equipped with a metal bellows filled with a volatile liquid. As the temperature rises, the liquid vaporizes in direct proportion, causing the bellows to expand. This, in turn, actuates the contact points. The thermostat shown has a temperature setting knob. If the thermostat is inaccurate, the temperature indicator can be adjusted with the indicator set screw.

The internal mechanism of a thermostat must be kept free of dust and lint. Accumulation of foreign material inside the thermostat housing will cause erroneous operation. Clean the contacts with a soft brush or by drawing a piece of hard-finished paper between them. Never attempt to clean the contacts in a thermostat with emery cloth or other abrasive material. When a thermostat needs maintenance other than routine cleaning and adjustment, it should be removed and replaced.

Limit control. A limit control is a device that responds to changes in air temperature in a warm-air heating system. The limit control has two distinct functions. The first function is to control the operation of the fire so that the temperature of the heating plant will never exceed safe operating limits. This function is distinctly for safety control. The second function of the limit control is to limit temperature of the heating system to provide better temperature regulation in the building. This function is particularly useful in controlling coal-fired heating systems where the coal bed continues to give off heat after the stoker motor has stopped. By lowering the setting of the limit control, however, it is possible to prevent the development of an excessively hot fire that would continue to throw off excessive amounts of heat after the thermostats have been satisfied.

The limit control for the warm-air heating system is usually referred as a bonnet thermostat, and it responds to temperature changes through a helical element. It is installed in the bonnet of the furnace, and it must be level to operate properly. The wiring should conform to local electrical ordinances. No lubricating oil should be used on the internal mechanism, and the cover should be in position at all times. When trouble is experienced with the unit, it should be replaced. This control is normally closed (NC), which opens on a temperature rise and is installed in the bonnet.

Fan switch. The fan switch, such as that shown in figure 3-17, controls the operation of the air supply fan or blower in a forced

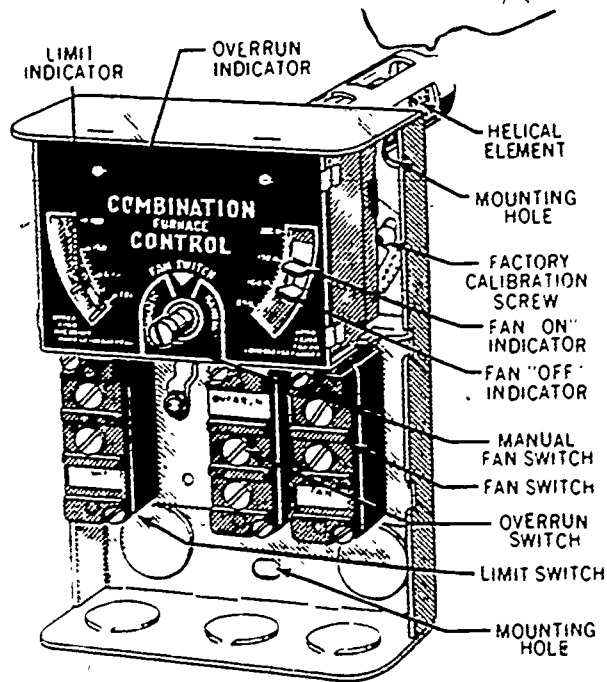


Figure 3-18. Combination furnace control.

warm-air heating system. The fan switch is similar in construction to the limit switch but operates in a directly opposite manner. The limit control stops the operation of a heating system because of excessive heat in the system, but the fan switch starts the fan when the air in the furnace bonnet rises to a predetermined temperature to be circulated in the rooms. The fan switch, helical thermostatic element, is installed in the bonnet of the furnace. The fan off temperature should be set at approximately 20° below fan on temperature. The fan switch in figure 3-17 completes or breaks the electrical circuit to the fan motor with a mercury switch. The cut-in and cut-out temperatures are adjusted with the differential adjustment lever. The temperature setting screw is used to adjust the maximum temperature setting of the unit. Since the helical element rotates the mercury vial, the switch must be installed against the bonnet in a level and rigid manner. A leveling indicator is provided on the switch illustrated for this purpose.

Combination control. The combination control shown in figure 3-18 combines the fan switch and limit control in one unit. Both controls are operated from one helical element installed in the bonnet, and is the most popular type of small furnace control because of its simplicity and economical installation. It does not have to be installed in a critical level position since it uses

mechanical switches. The fan can be turned on or off manually at the switch. Sliding tabs are provided for setting the on and off positions of the fan and high limit control.

Humidifiers. Water vapor in the atmosphere is called humidity. There is a limit to the amount of water vapor that a pound of dry air can hold at a fixed temperature. When this limit (saturation) is reached, the relative humidity of the air is 100 percent. Since it cannot hold additional moisture any water vapor introduced to the air after saturation is dropped through condensation.

To prevent excessively low relative humidity inside an operating heating system, the air can be humidified. Figure 3-19 illustrates a typical humidifier of the kind used with older model warm-air furnaces at some Air Force installations. Humidifiers are usually installed in the warm-air plenum chamber. A needle valve is actuated by a float to maintain a given level of water in a pan. Hot, dry air from the furnace absorbs (evaporates) the water from the pan, thereby increasing its relative humidity. (Be sure to check installation of the pan to see that it does not overflow on the combustion chamber or furnace radiator.) This type of humidifier does not provide close control of relative humidity conditions.

Humidifiers are usually standard equipment with almost all types of warm-air furnaces. Humidifiers for warm-air furnaces are usually the pan type. Unless the water used is comparatively free of solids these units require frequent attention, since the float can stick in the open position or the valve may clog. Overflowing of the pan due to valve stuck in open position can result in a cracked heating section, and a clogged inlet valve will make the humidifier inoperative.

Humidistat. A humidistat senses the relative humidity of the air in a space or

system. It is designed with sensing elements made of wood, hair, or animal membrane.

Under normal operating conditions, the humidistat will sense humidity within 1 percent relative humidity. A humidistat sends electrical signals to operate dampers, valves, or other devices that control relative humidity. For example, when a humidifying device having a spray nozzle is used, a solenoid valve is installed ahead of the nozzle. The humidistat in the conditioned space automatically energizes the solenoid when the relative humidity drops below the humidistat setting. As soon as the humidity in the conditioned space is brought up to that needed to satisfy the humidistat, the circuit is opened and the solenoid shuts off automatically.

The humidistat is a very delicate instrument and must be handled with care. Keep the instrument encased at all times and free of dust and other foreign materials. See that it is mounted securely. Locate it where there is a good circulation of air around its sensing element.

Control Installation. Proper care in handling and installing controls will assist in obtaining good performance from a warm-air heating system. Brochures are available on installation of controls from each manufacturer and should be followed while working with these controls. Always be sure that a control is correctly wired. Many malfunctions are attributed to not adhering to this general principle. All control terminals are usually colored, lettered, or numbered, and the manufacturers furnish wiring diagrams which are simple and easy to follow.

Thermostats. Always install a thermostat on an inside wall at eye level and in a place where it will be affected by average room temperature.

Make sure there is free circulation of air at

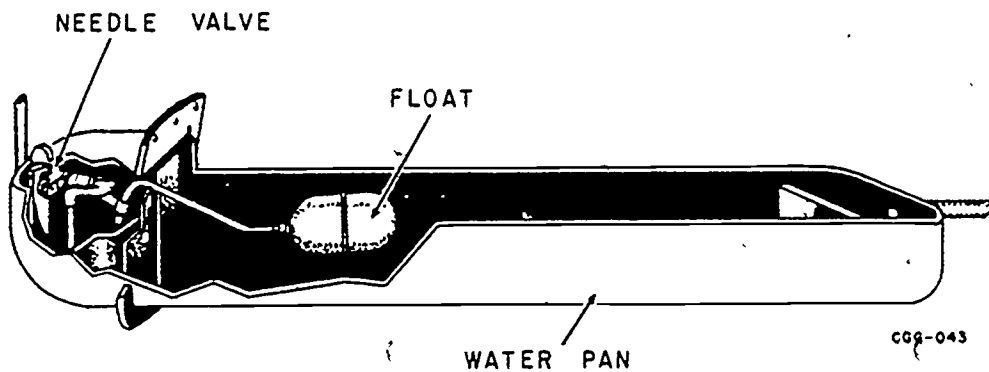


Figure 3-19. A typical humidifier.

the point of mounting and that the thermostat is unobstructed by furniture, doors, and the like. Do not mount the thermostat where it will be affected by drafts from hallways or stairways or where it will be affected by the warm-air stream from air registers. Do not install thermostats close to concealed warm or cold water pipes, warm-air ducts, or on furnace room walls. Always install a thermostat away from the sun's rays, because the radiant heat from the sun will cause a shifting of the control point.

Limit control, fan control, and combination control. The same fundamentals of installation apply to all three of these controls. In installing these controls, insure that in the operating position no portion of the actuating elements touch the crown sheet. Install these elements so that the effects of radiant heat are kept to a minimum. Install the controls so that they will be subject to rapid changes in temperature of the furnace. Do not install the control elements where they will be affected by cold air returns or where circulation of air around them is restricted by baffles or deflecting fins.

Use a swivel mounting bracket if space permits. If a control must be mounted flush on furnace, be sure that an asbestos insulator, 1/2 inch thick, if possible, is placed between furnace and control. It is important to limit temperature inside the control to 150° F., if possible, to prevent damage to switches and maintain electrical rating of load contacts.

Under no circumstances should fan load rating of control be exceeded. For maximum efficiency and comfort, fan control setting

300

should be as low as possible without discharge of cold air. For most installations, a limit control setting of 175° F. to 200° F. is satisfactory. After installation of these controls, as all controls, replace the cover. This protects the mechanism and discourages unauthorized tampering with the settings.

Exercises (433):

1. State the principal operations and the condition controlled by each of the following:
 - a. Thermostat.
 - b. Limit control.
 - c. Fan switch.
 - d. Combination.
 - e. Humidifiers.
 - f. Humidistat.
2. Match the heating controls in column A to the installation locations in column B by writing the correct letter in the blank provided. Column B items may be used once, more than once, or not at all.

- Column A
1. Thermostat.
 2. Limit control.
 3. Fan switch.
 4. Combination control.
 5. Humidifiers.

- Column B
- a. Installed in the bonnet of the furnace.
 - b. Installed in the warm-air plenum chamber.
 - c. Mount the control securely where there is a good circulation of air around the sensing element.
 - d. Install on an inside wall at eye level.

Hot-Water Heating

SYSTEMS IN which water is heated at a central source and circulated through pipes to radiators, connectors or unit heaters are called hot-water heating systems. These systems are considered very useful carriers of heat and may be classified according to their operating temperatures.

4-1. Fundamentals of Hot-Water Heating

Hot-water heating is preferred by many because the amount of heat delivered by the system can be easily adjusted to suit conditions. When the hot-water boiler is fired automatically with gas or oil, temperatures of the circulating water can be kept as low as 70° F. This makes hot-water an advantage in areas where persons must be comfortable in only mildly cool weather.

434. Give the temperature range for hot-water heating and tell how the amount of heat transferred from the flue gas to the water is determined.

Hot-water heating systems are classified as low, medium, or high-temperature water. High-temperature water, because of its different characteristics, will be covered in a separate chapter. Low-temperature water (LTW) has a temperature span of 100° F. to 220° F., and the medium temperature water (MTW) ranges from 220 to 300° F. water temperature. This system is generally used for industrial purposes, certain types of refrigeration, and large space heating systems.

In hot-water heating, a hot-water boiler is connected by a system of pipes to radiators, connectors or unit heaters situated at strategic places for maximum comfort. These risers feed the hot water. Another system of pipes (returns) carries the water from the radiators, connectors, and unit heaters back to the

boiler. To maintain proper pressure in a hot-water system and to prevent steam formation, an expansion tank is connected to the boiler.

Hot-water boilers, regardless of their design and type, operate on the same basic principle. The fuel burns in the combustion chamber to produce heat. When the resultant heat is radiated and conducted to the water in the water jackets surrounding the combustion chambers and passes through the boiler tubes, heat is liberated by the flue gases and absorbed by the water surrounding the tubes. The amount of heat transferred into the water depends on both the rate of heat conduction through the metal in the boiler tubes and the rate of water circulation in the boiler. For this reason, boilers are designed with baffles to hold the hot gases as long as possible. The gases give up maximum heat before passing into the chimney.

Exercises (434):

1. What are the temperature ranges for LTW and MTW?
2. What determines the amount of heat transferred to the water from the flue gases?

4-2. Hot-Water Boilers and Accessories

Hot-water boilers come in many shapes and sizes. You will probably perform maintenance on many different kinds of hot-water boilers during your military commitment. Hot-water boilers are constructed with a firebox for burning fuel and have provisions for passing

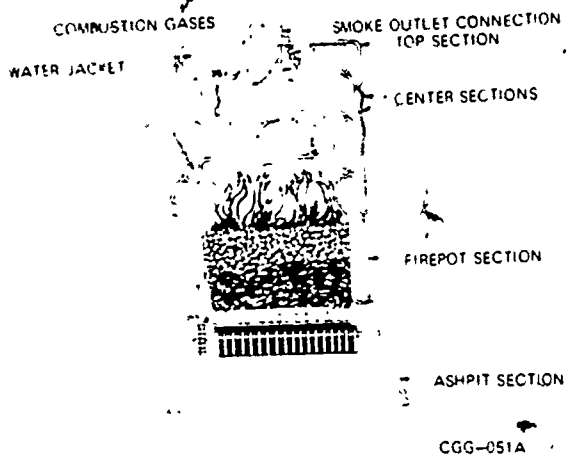


Figure 4-1 A typical round cast iron boiler.

hot gases over the heat absorbing surfaces of the boiler. Both ends of the boiler have openings for cleaning the boiler tubes and washing the interior of the boiler. Each boiler has specific fittings and accessories for control safety and specific heating jobs.

435. List the types of hot-water boilers and answer questions on construction features of each type.

Cast Iron Hot-Water Boilers. Cast iron hot-water boilers vary in size from small domestic units to moderately sized units

capable of developing about 30 horsepower. These boilers are usually constructed of several sections joined together by some form of connection. Push nipples, one kind of connection, are round pieces of metal pipe tapered at both ends. The boiler sections are ordinarily connected by pipes known as header connections.

Cast iron boilers normally do not have brick settings. Usually, the only bricks used in connection with these boilers are those sometimes used as a base for the boilers. In most cases, the bases are made of cast iron. Cast iron boilers can be further classified as round and square types.

Round cast iron type boilers. Round cast iron type boilers vary somewhat in construction. In general, however, they are typified by the unit shown in figure 4-1. This unit consists of a top section, in which the outlets and safety valve tappings are located; a number of intermediate sections, depending upon the amount of heating surface required; a firebox section, in which the return water tappings are located; and a base and an ashpit. Round cast iron type boilers are small and compact, and are built in sizes capable of supplying up to 1,700 square feet of radiation.

Square sectional cast iron type boilers. Square sectional cast iron type boilers are similar to the typical unit shown in figure 4-2. This boiler consists of a front and rear section and a number of intermediate sections, depending on the size of the boiler. The

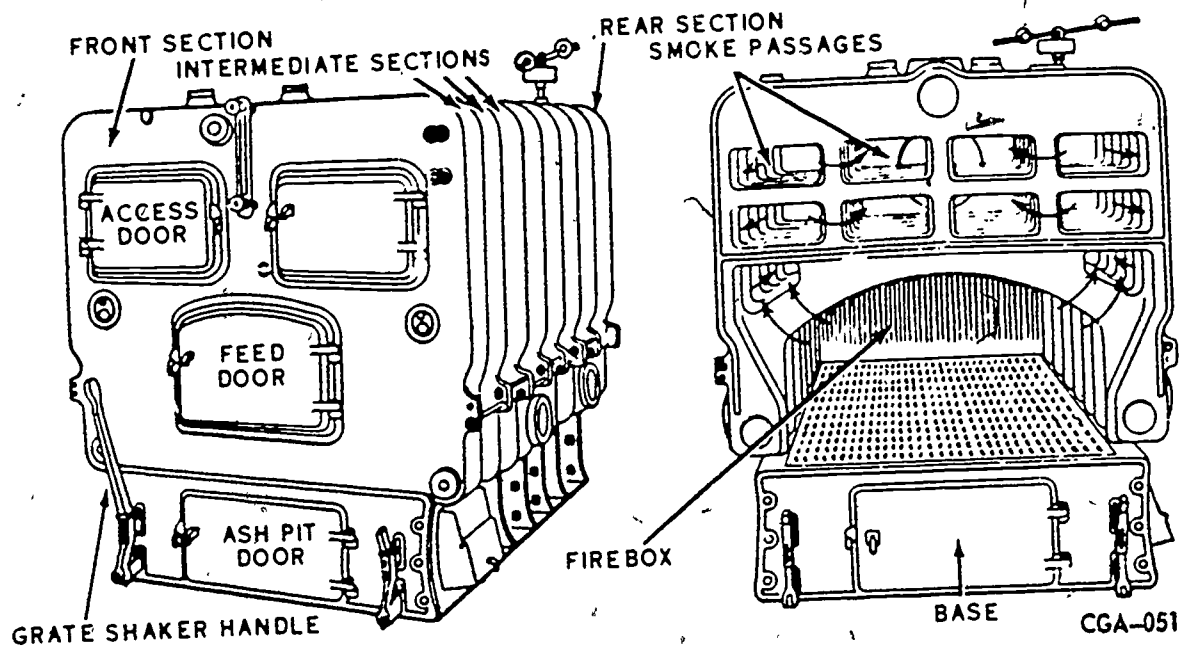


Figure 4-2. A square sectional cast iron boiler.

sections are connected on each side at the top and bottom either by push nipples or by an outside header. When nipples are used, these sections are held firmly together by rods and nuts.

The boiler shown in figure 4-2 has a separate base that does not contain water and, therefore, requires a floor of fireproof construction. Boilers that have water in their bases are referred to as wet-bottom boilers. These boilers are relatively small water units that may be installed on floors constructed of combustible materials. This method of installation, however, is not desirable.

The construction of square sectional boilers is ordinarily such that the sections can be taken through regular sized doors for assembly inside the boilerroom. This is a distinct advantage from the standpoint of both installing new equipment and replacing broken sections. Cast iron boilers resist the chemical action of corrosive agents much better than steel boilers.

The disadvantage of cast iron hot-water heating boilers is the danger of the sections cracking or breaking when improperly handled or fired.

Steel Hot-Water Boilers. Most steel hot-water boilers are constructed in two sections. One section consists of the water jackets, combustion chamber, and smoke passages. These components are either welded or riveted together as a unit. The other section consists of the base and either grates or burner, and is constructed according to the type of fuel used.

Another steel boiler is a horizontal unit of the portable type having an internal firebox surrounded by water lanes. It rests either on a cast iron or a brick base. The front part of the boiler rests on a pedestal. A disadvantage of this one-piece steel boiler is that it is heavy and requires special equipment to lift it.

Package Type Boilers. Some boilers are called package boilers. These are complete units including fittings and accessories. The package boiler is generally one with self-contained firebox and is somewhat portable because they are normally mounted on skids. This accounts for the term "package-boiler." Package boilers usually have the same accessories and controls as the comparable stationary type of hot-water or steam boiler. To avoid the danger of cracking the boiler sections during transportation, cast iron boilers are seldom used as package boilers.

Exercises (435):

- 1. List the types of hot water boilers.

- 2. What is a basic difference in the construction features between a cast iron and steel hot water boiler?

- 3. What determines how the sectional of a steel hot water boiler, which contains the base and burner, is constructed?

- 4. When sections of a cast iron boiler are joined by push nipples, what is used to keep these sections stabilized?

- 5. What is a distinct construction advantage of a square sectional cast iron type boiler?

436. Specify a major factor for installing boilers in a hot-water heating system and factors governing the construction of the foundation.

It is very important that a boiler has a good foundation. The top surface of the foundation should be level to insure proper alignment of the boiler sections and, thus, eliminate undue strain on the boiler castings. The furnace foundation should be poured separately from the finished floor. Too, it should be of sufficient width and depth to afford ample support for the boiler without any settling, and it should extend 2 inches above the finished floor. Assembly procedures vary in detail for various boilers. However, manufacturers furnish detailed procedures for the assembly of their boilers. Usually the plans for the foundation can be procured from them.

Exercises (436):

- 1. Specify major factor involved in hot-water boiler installation.
- 2. What factors govern the construction of the foundation?

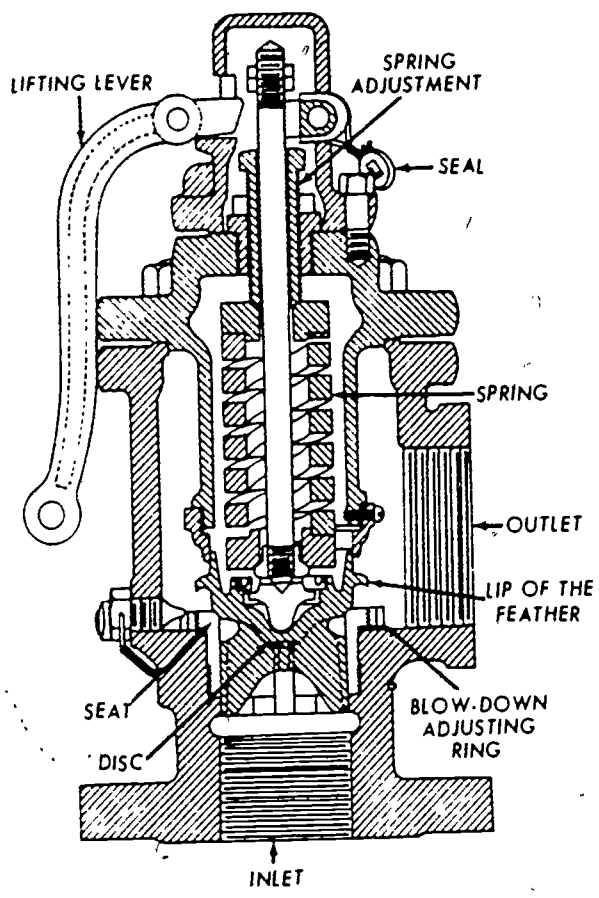


Figure 4-3. A typical pressure relief valve.

437. State the function, operating characteristics, and fundamentals of testing or maintaining a safety relief valve.

All boilers have certain accessories and fittings that promote safety and ease of operation. One such fitting is the safety relief valve.

Safety Relief Valve. In a closed hot-water heating system, there is always the possibility of building up a dangerous pressure. Consequently, a pressure relief valve is installed to allow this pressure to escape. A typical pressure relief valve is shown in figure 4-3. This valve is usually on the top of the boiler. It contains a spring-loaded valve that unseats when the pressure in the system increases to a predetermined value, thereby allowing pressure to escape until it drops to a safe point. A valve of this type can be adjusted for different pressures. The valve shown in the illustration has a lifting lever to permit operating the valve manually. It also has a replaceable seat and disc. The valve spring adjustment that controls the pressure at

which the valve will operate, is accessible from the top of the valve after the cover is removed. The cover is sealed to prevent unauthorized tampering. The outlet from the valve should be connected to a drain line.

Pressure relief valves may eventually corrode and stick if they are not forced to operate occasionally. It is good practice, once each month, to increase the pressure to a point that operates the valve. When the pressure on the gage exceeds the setting of the valve, check the valve pressure setting with an accurate gage and report any malfunctions to your supervisor. If the valve has to be reset, it must be done by a person certified to make such adjustments.

The gage that is used to check the pressure of the boiler is illustrated in figure 4-4. The gage, which is connected to the top of the boiler, indicates system pressure in pounds per square inch. This gage is usually a combination gage that indicates also boiler water temperature and altitude. The type shown in figure 4-4, however, indicates pressure only.

Very little maintenance is required for this unit, other than to clean the glass so that the gage can be read. Some types of pressure gages are constructed so that they can be recalibrated, but the proper equipment to do this is not always available in the heating shop. To properly calibrate a pressure gage, you must have either a master gage set or a deadweight tester.

As we mentioned previously, observation of the pressure when it pops, normally is part of the operating tasks. Also, it is a good idea to hand blow safety valves monthly. Do this

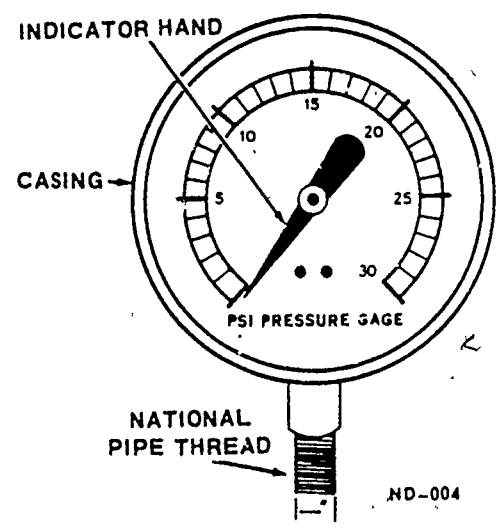


Figure 4-4. A typical water pressure gage.

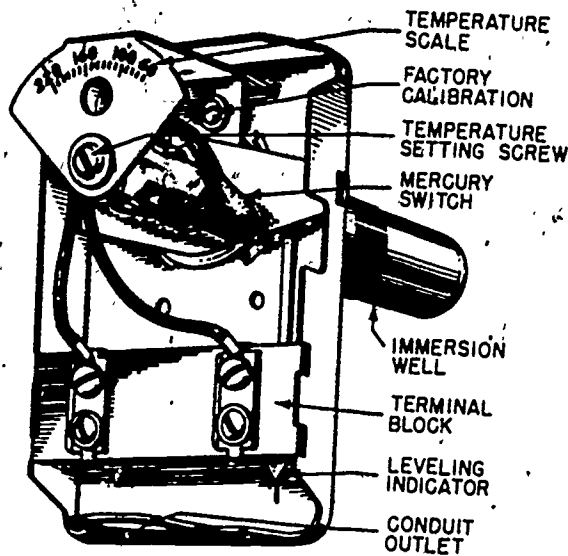


Figure 4-5. A typical immersion-type aquastat.

maintenance functions should you perform?

438. Point out the function of the aquastat and state the prime objective in replacing aquastats.

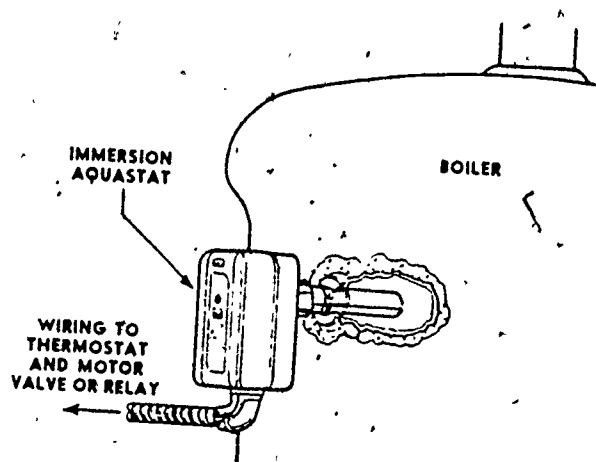
Limit controls for hot water installations are commonly called aquastats. We covered aquastats previously in another chapter. The function of an aquastat is to prevent steaming of boiler water and to reduce operating cost by eliminating unnecessary firing. Aquastats may be of the mercury type, such as illustrated in figure 4-5, or contain a bimetal element. Most aquastats are of the immersion type. This type has its sensing element inserted in an immersed copper well. The sensing element in the immersion well may be a metallic spring or a liquid filled bulb. At the temperature setting of the instrument, the rotation of the spring or expansion of the liquid, will rotate the mercury switch and open or close the circuit according to the type of service the switch is to perform. Since a mercury switch is used, the instrument must be installed and maintained in a level position or it will not operate properly. The temperature at which the switch will operate is set on the temperature scale with the temperature setting screw. Figures 4-6, and 4-7

when the boiler pressure is from 80 to 85 percent of the preset popping point. Keep the valve wide open for at least 10 seconds to blow dirt and scale from the seat. Close the valve by suddenly releasing the lever.

Each day you should inspect the safety relief valve for deterioration or inadequate support of the valve exhaust piping. Make sure the valve discharge does not endanger personnel. Check for steam leakage through the valve due to an abnormal buildup of scale.

Exercises (437):

1. What is the function of a safety relief valve?
2. How does a safety relief valve operate and what will cause it to stick?
3. What is used to test a safety relief valve and when it needs to be reset who will reset it?
4. What should you, as an operator, check for during your daily inspections?
5. To insure the safety relief valve is operating properly, what operational preventive



CME-119

Figure 4-6. Installation diagram of an immersion-type aquastat in a hot-water boiler.

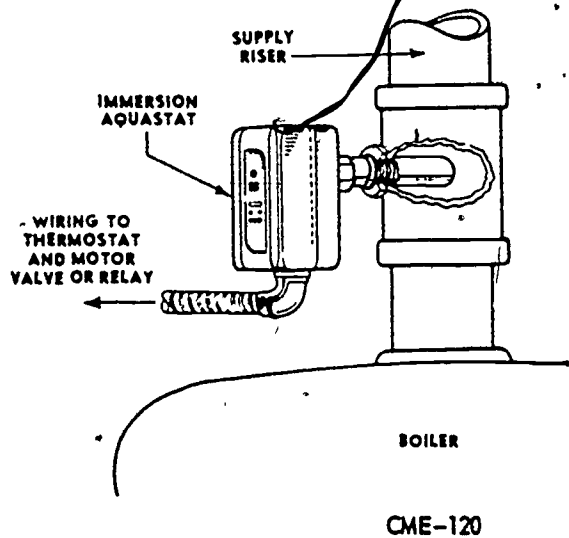


Figure 4-7. Installation diagram of an immersion-type aquastat in a vertical riser of a hot-water boiler.

are typical locations of the immersion type aquastats for hot-water systems.

The immersion aquastat can be removed from its copper well for repair or replacement without shutting down and draining the system.

Exercises (438):

1. Point out the function of the aquastat.
2. State the prime objective in replacing a mercury-type aquastat.

439. Explain the function of pressure regulating valves, list the components requiring annual maintenance and state the maintenance performed on these items.

The water pressure recirculating valve is part of the feedwater supply of a closed hot-water system. This valve is normally called a reducing valve. A pressure reducing valve is usually installed in the makeup or coldwater line to the boiler. This valve automatically keeps the closed system supplied with water at a predetermined safe pressure. The maximum permissible pressure

for standard hot-water heating systems is 30 psi; therefore, the reducing valve setting should be as low as possible. Valves are usually factory set at 12 psi pressure; this equals a static head of 27.6 feet of water (suitable for buildings with one, two or three stories). However, if the static head of the system is high, boilers with higher operating pressure may be required, and the reducing valve is set correspondingly higher. Reducing valves have either inlet or outlet markings or directional arrows to indicate the proper flow direction.

Only authorized and trained personnel should repair, calibrate, or adjust water pressure regulating valves. Observe the operation of the valve for proper functioning, check for leaks, and stop the leaks in the stuffing box as soon as possible. Once a year, or more often if required, the valve should be dismantled, components should be cleaned and inspected for wear, corrosion, erosion, pitting, deposits, or other defects. Check the settings and adjustment of the valve.

All defective parts should be repaired or replaced as soon as possible after the inspection. Examine valve stem; replace or metalize, if necessary. Change or regrind valve and seat as required. Change valve to smaller size if excessive cutting indicates an oversized valve. Repack stuffing box.

Exercises (439):

1. Explain the function of the water pressure regulating valve used in a hot-water system.
2. What parts or components require annual maintenance?
3. If the valve seat is not seating right, what maintenance is required?

440. Name the types of expansion tanks, and given a list of statements, select those that show tank location or pressurization method.

Expansion Tanks. Every hot-water heating system should have an expansion tank to

handle the expansion and contraction of water that occurs as its temperature changes. The function of the expansion tank is similar to that of the expansion drums in HTW systems. The expansion tank should be large enough to permit the water volume to change without causing undue strains on the equipment. When water is heated from 40° F. to 200° F., its volume expands approximately 4 percent; this expansion is handled by an expansion tank or by a relief valve that discharges the excess water. The expansion tank must be large enough to hold 1.5 gallons of water for every 25 gallons that will be heated. The excess water is stored in the expansion tank until the water temperature becomes lower; it is then returned to the system.

Open-tank system. In open-tank systems, the expansion tank is freely vented to the atmosphere. Normally, these systems are limited to installations with operating temperatures of 180° F. or less. Operation at higher temperatures, which would be near the boiling point of water at atmospheric pressure (212° F.), could be troublesome. In open tanks, overflow and vent pipes are used instead of relief and air inlet valves.

Closed-tank system. This system uses an air-tight tank that is sealed to prevent free venting to the atmosphere. Therefore, heating systems using it can be pressurized and operated over a wide range of temperatures

and pressures. Thus, when the saturation pressure is raised to correspond to the desired temperature, the system can be operated above 212° F. In operation, as heated water expands, the excess water moves into the tank and compresses the entrapped air, thereby increasing the pressure on the system. When the water temperature lowers, the water contracts, air in the tank expands, the excess water returns to the system, and the pressure drops. A closed expansion tank must be large enough to keep a reservoir of compressed air above the water level to cushion the excess water that enters. Thus, the tank must provide space for changes in both water and air volume. In closed tanks, a water gage and air inlet, water inlet, and drain and relief valves permit the operator to observe and adjust the proportion of the air in the tank. A source of supply of compressed air for renewing the air cushion is highly desirable, (air compressors are appropriate), especially in large hot-water systems where it is inconvenient and impractical to drain water in the system so as to introduce more air.

If the tank is too small or if it does not contain enough air, two undesirable conditions can occur. First, as temperature increases, the water will expand and the system pressure may increase above the permissible level. This will cause the relief valve to open and waste water. Second, as temperature drops, the water contracts and the pressure may drop below the permissible minimum. Air will not vent from the system and additional air may be drawn in if the high points of the system have automatic air vent valves.

Size of Expansion Tanks. The capacity of the tank depends basically on the amount of water in the system and the operating temperature range. A minimum volume of 6 percent of the total system water (boiler, piping, and heating equipment) is recommended for open tanks. The size of closed tanks is usually calculated by formulas that take into account the following factors: the volume of water in the system, tank operating pressure, temperature operating range, pressure in the tank when water first enters (usually atmospheric), and the initial fill (or minimum) pressure in the tank.

Location of Expansion Tanks. Open tanks are usually installed at least 3 feet above the highest heat transmitter so that the tank and connecting piping are protected against freezing. In forced circulation systems, the tank is normally connected to the suction side of the circulating pump to maintain a

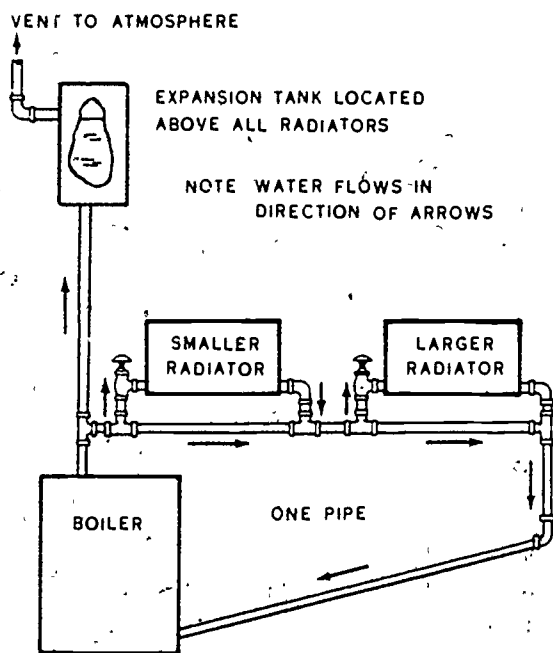


Figure 4-8. A one-pipe open-tank gravity hot-water distribution system.

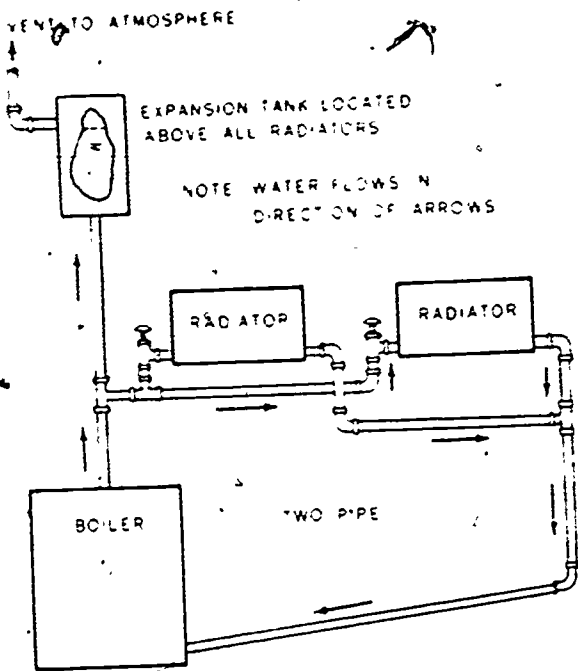


Figure 4-9 A two-pipe open-tank gravity hot-water distribution system

constant pressure head on pump suction and to prevent subatmospheric system pressures. The location of closed tanks depends on the type, size, and design of the installation. Regardless of location, the point of junction between tank and system is under constant pressure, even when the pump is not operating. Designers consider this fact when setting up piping arrangements. When possible, connect the expansion tank by a direct pipe to the highest point of the boiler. This arrangement lets air pass easily to the tank. In a hot-water system, the rate at which water under pressure absorbs air increases when pressure increases and decreases when temperature increases.

Exercises (440):

1. Name the types of expansion tanks used with hot-water heating systems.
2. From the following statements, select those that show expansion tank location or pressurization method; place an X in the blank provided.
 - a. Use compressed air to renew (pressurize) the cushion of the open tank.
 - b. Use compressed air to renew (pressurize) the cushion of the closed tank.

- c. Install closed tanks at least 3 feet above the highest heat transmitter.
- d. Install open tanks at least 3 feet above the highest heat transmitter.
- e. Install the tank on the suction side of the circulating pump in a forced circulation system.
- f. Closed tanks must be installed on the same level as the heat transmitters.
- g. Location of closed tanks depends on type, size and installation design.

4-3. Distribution Systems

As we mentioned at the beginning of this chapter, water is heated at a central source and circulated through pipes to radiators, connectors, and unit heaters. There are two general types of hot water distribution systems. The first type is the gravity system in which the circulation depends on the weight difference between the hot column of water leading to the radiators and the relatively cooler, heavier column of water returning to the boiler. The second type is the forced-circulation system in which water is circulated by a pump.

441. Select from given statements those that show system design or principle of operation for hot water distribution piping systems.

Gravity Hot-Water Distribution System. The distribution systems and piping for hot-water heating systems and for domestic

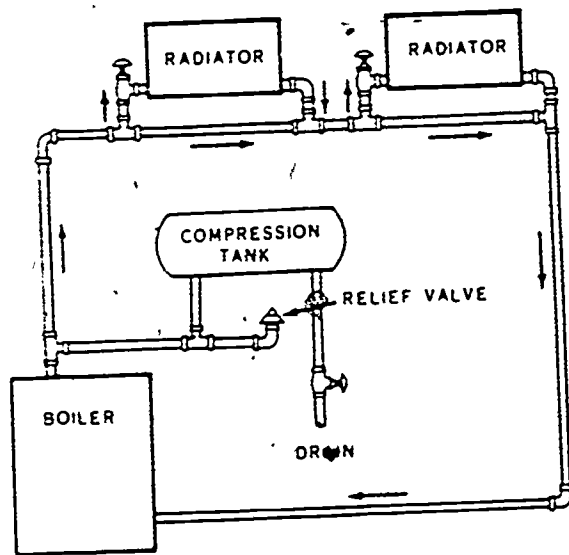


Figure- 4-10. A one-pipe closed-tank distribution system.

hot-water supply systems are simpler in design than those for steam, because there are no traps, drips, or reducing valves. Several items such as supports, insulation, and some valves and fittings are the same for both steam and hot-water distribution.

Gravity hot-water distribution systems operate because of the gravitational pull on the heavier cool water that sinks as the heated water becomes lighter and rises. At this point, we discuss some of the types of gravity systems that are currently used.

One-pipe open-tank gravity system. The one-pipe open-tank gravity distribution system, shown in figure 4-8, consists of a single distribution pipe that carries the hot water to all of the radiators and returns it to the boiler. This system is easy to install and moderate in cost. However, this system is not recommended.

Two-pipe open-tank gravity system. Many hot-water gravity distribution systems are two-pipe open-tank systems, such as the one illustrated in figure 4-9. This heating system is constructed with separate water mains for supplying hot water and returning cold water. The radiators are connected in parallel between the two mains. In the two-pipe open-tank gravity system, the distributing supply mains are either in the basement with upfeed to the radiators or in the attic. When the system is in the attic, it has overhead downfeed supply risers. The return mains are in the basement.

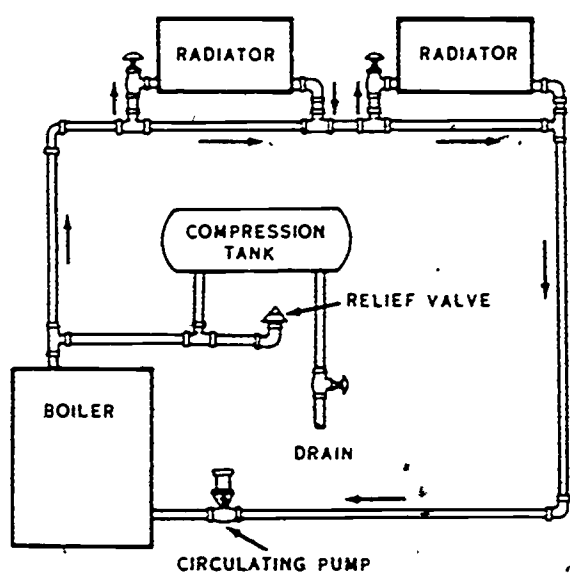


Figure 4-11. A one-pipe closed-tank distribution system with a circulating pump.

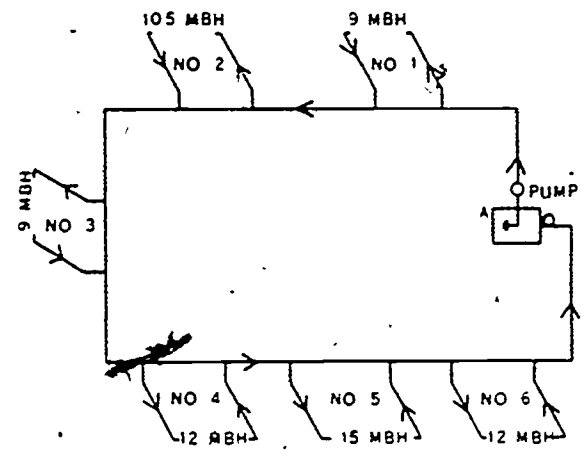


Figure 4-12. One-pipe water circulation system.

One-pipe closed-tank distribution system. A one-pipe closed-tank gravity hot-water distribution system, like the one shown in figure 4-10, is similar to the one-pipe open-tank gravity hot-water heating system except that the expansion tank is a pneumatic compression tank not open to the atmosphere. When the water in a closed-tank system is heated, it expands into the pneumatic compression tank. This action permits system operation at a much higher water temperature, without boiling, than the temperature in the one-pipe open-tank gravity system. This also results in higher heat emission from the radiators.

Forced-Circulation Hot-Water Distribution System. Forced-circulation hot-water distribution systems have several advantages. They permit the use of smaller pipes and allow the installation of radiators at the same level as the boiler, or below, without impairing water circulation. By using a circulation pump, a positive flow of water is assured throughout the system. In larger installations, especially where more than one building is served, forced circulation is almost invariably used. With the development of the circulation pump of moderate cost, the forced-circulation system is being used more extensively in small heating installations.

As in gravity systems, forced-circulation system can consist of a one-pipe or a two-pipe, upfeed or downfeed, and can be equipped with a direct or a reverse return. Although these systems usually have closed expansion tanks, they may have open tanks.

One-pipe system. Figures 4-11 and 4-12 illustrate a one-pipe circulation system. In this system, a single main is carried entirely around the building from the pump discharge to the boiler inlet (return line) as shown. The

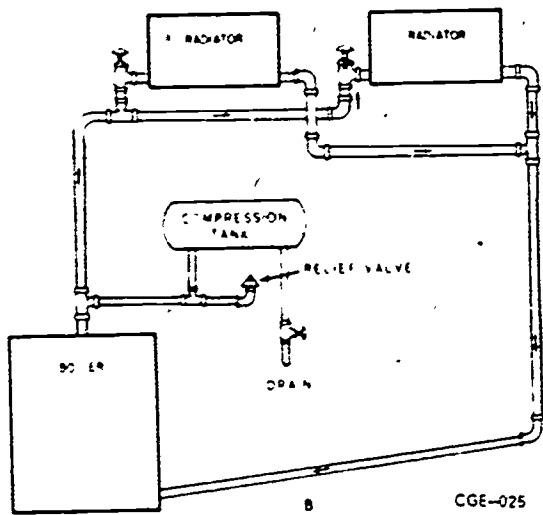


Figure 4-13. A two-pipe, closed-tank, forced circulating system.

water flow through the main is constant, except when some of it is by-passed through the heat distributing units. Therefore, size of the main circuit remains constant from the first to the last heating unit. Supply risers are taken off the main to feed the heat-transmitting units and the returns from the units are reconnected to the main, a short distance along the line. This can be done without interfering with normal operations because differential pressures of heating unit inlets and outlets cause water flow. Differential pressure is produced by the constant drop, from pump discharge to suction, of the pressure head in the main.

Two-pipe system. The two-pipe system, as shown in figure 4-13, has two mains: the supply main feeds water to the risers that serve the heating units, and the return main collects the water returned from those units. The two mains run side by side; the supply main decreases and the return main increases in size where the branches connect. Since the heating units of a two-pipe system are connected parallel, it requires a minimum pumping head. Also, if throttle valves or restricting orifices are used in the risers, the flow through individual units can be adjusted easily over a wide range. However, the two-pipe system requires more pipe and pipe fittings than the one-pipe system. Two-pipe systems are classified as direct-return and reverse-return (see fig. 4-14).

Direct-return system. The heating units of the two-pipe, direct-return system are parallel. Nevertheless, the water taken from the main to feed the first radiator is returned first; that removed for the second radiator is returned second; and so successively throughout the heating units. Since this procedure causes a progressively greater friction loss in each additional circuit, the flow circuits become hydraulically unbalanced. This condition may cause the first radiator to have a greater flow than is required to develop its full capacity, while in a large system, the flow through the last unit may be so small that practically no heat is delivered. To balance the system, carefully select pipe sizes to compensate for the differences in length and the consequent

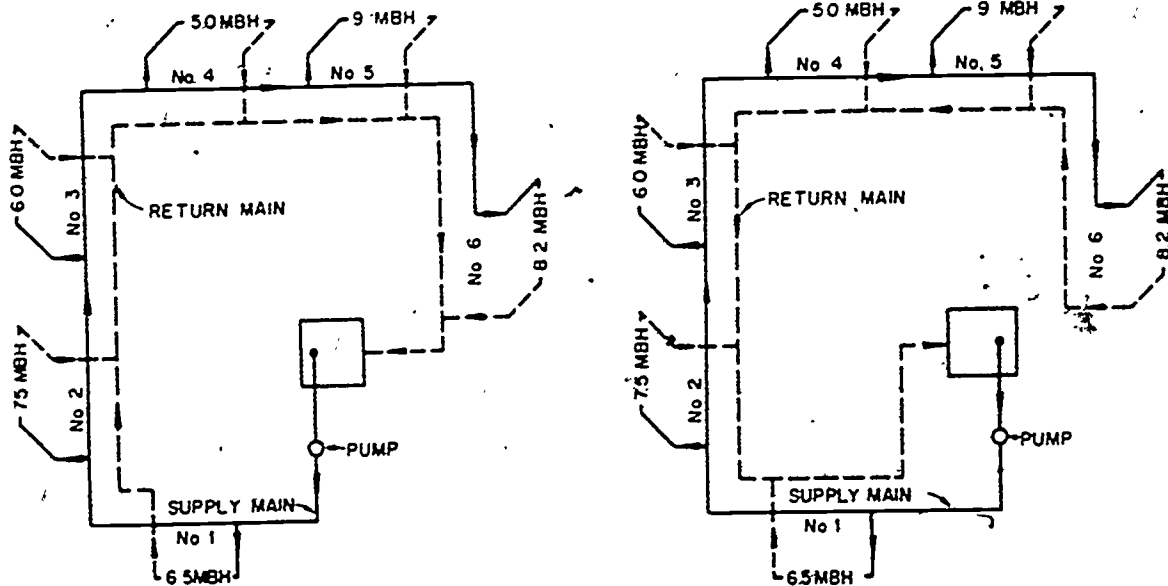


Figure 4-14. Two-pipe systems.

friction loss of each circuit. (A balanced system must have the same pressure drop through each piping circuit at design flow rate.) Restricting orifices or throttle valves can also be used to correct flow distribution and to balance the system after it is placed in service.

Reversed-return system. In the two-pipe, reversed-return system, the water taken from the main to feed the first radiator is returned last to the return main; the water supplied to the last radiator is returned first. As a result, all unit circuits are of approximately equal length, a condition conducive to system balance. The reversed-return system may require more pipe than the direct-return. However, its inherently better flow distribution and natural balance without the aid of additional valves or orifices, compensate for the additional cost.

Series-loop system. A series-loop system may have one or more loops or circuits. All the heat transmitters in a circuit are installed in succession (in series), and the same amount of water flows through each and through the connecting main. For a given available head, the length of the circuit and the number and type of heat transmitters determine the water flow rate and temperature drop. The water temperature decreases progressively as the water flows through each successive heating unit. To compensate for the temperature drop, some designers increase each unit heating surface in proportion to the distance from the source of heat supply. Series systems are frequently used in connection with baseboard radiation. But neither the flow nor the temperature of the water supplied to individual heating units can be regulated. Therefore, unit heat delivery is usually controlled by air dampers in the baseboard radiation cabinets.

Exercises (441):

From the following statements, select those that show system design or principle of operation for hot-water distribution systems by placing an X in the blank provided.

- 1. Hot water piping systems must have traps, drips, and reducing valves.
- 2. Water circulates because of the gravitational pull on the heavier cool water.
- 3. The one-pipe, open-tank gravity system has good circulation with small radiator temperature drops.
- 4. The two-pipe, open-tank gravity system has separate mains for

supplying hot water and returning cold water.

- 5. The one-pipe, closed-tank gravity system has a compression tank.
- 6. The closed-tank system operates with smaller pipe and has a higher heat emission.
- 7. An open-tank reversed return main goes directly back to the boiler.
- 8. Forced circulation systems permit the installation of radiators on the same level as the boiler.
- 9. If the forced system is designed for a 20° F. temperature drop, the boiler capacity is increased.
- 10. All the heat transmitters are installed in succession in the series-loop system.
- 11. Water temperature and flow cannot be regulated for individual heating units in the series-loop system.

442. From two lists match the hot-water distribution system components with the purpose they serve.

Distribution System Components. The component parts of a hot-water distribution system include: pipelines, radiators, unit heaters, circulating pumps, reducing valves, flow-control valves, and special flow fittings.

Pipelines. The piping system constitutes the closed passageway for the delivery of hot water to the points where it is used. Pipelines are made up of lengths of pipe fastened by screwed, flanged, or welded joints. They have valves and fittings such as tees, unions, and elbows, according to the needs of the installation. Pipelines are supported by hangers and fastened by anchors. Expansion joints or loops allow for expansion.

Pitch mains and branches of the pipeline so that the air in the system can be discharged through open expansion tanks, radiators, and relief valves. The pitch is generally not less than 1 inch for every 10 feet. The piping arrangements for a new system should make provision for draining the entire system.

Radiators. The radiator transfers heat from the hot water in the pipes of a hot-water heating system into the air in a room. A radiator is usually constructed of cast iron and assembled in sections, as shown in figure 4-15. You can replace damaged radiator sections without replacing the entire radiator assembly.

Unit heaters. A unit heater is one used to heat a localized area. The heater consists of a

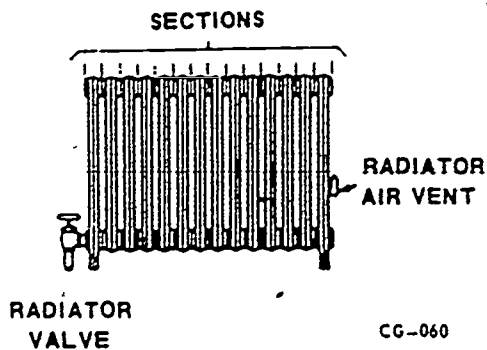


Figure 4-15. A typical cast iron sectional radiator.

heating coil that is supplied with hot water. The coil is usually of the finned type, and air is circulated over it by an electric fan.

Reducing valves. Reducing valves, radiators, and unit heaters were all covered previously in this course.

Circulating pumps. A forced hot-water heating system has a water circulating pump in the return line near the boiler. This pump insures the positive flow of water regardless of the height of the system or the drop in the water temperature. Greater velocities of waterflow are obtainable with forced circulation than with gravity circulation.

Circulating pumps are free of valves and float control elements. They are operated under a sufficiently high water inlet temperature to eliminate the difficulties vapor binding causes. Electric motors usually operate the pumps.

During maintenance servicing, check the pump carefully for proper rotation, and lubricate the electric motor and pump according to the manufacturer's instructions. Periodically clean the pump of sand, rust, and other foreign matter that has collected in the pump casing. Be sure that the pump rotates freely, and that the shaft packing glands, if there are any, are not drawn up so tight that they score the shaft. Pumps will be covered extensively in Volume 4.

Flow-control valves. Forced hot-water circulating systems use the flow-control valve, shown in figure 4-16, that is normally installed in the distribution main. This valve prevents gravitational flow of water through the system. The valve does not offer any serious resistance to the flow of water when the circulating pump is in operation. However, when the pump is not operating, the small gravitational head of water cannot open the valve. Each week, check the flow-control valve for proper operation and

free movement. Examine the valve for water leaks and repair it when necessary.

Special flow fittings. Various types of special tees that are designed to deflect main-line water into the radiator branches are used in one-pipe and two-pipe forced-circulation systems. These fittings are designed and calibrated to the size of the radiator and system operating temperature. Fittings of this type are required with one-pipe forced-flow systems, and they do equally well for radiators above and below the distribution mains.

Exercises (442):

Match the components listed in column A with the component purpose that relates in column B by placing the letter in the blank provided.

- Column A**
- 1. Pipelines
 - 2. Radiators
 - 3. Unit heaters
 - 4. Circulating pumps
 - 5. Flow-control valves
 - 6. Special flow fittings

- Column B**
- a. Used to deflect main-line water into the radiator branches.
 - b. Assure a positive flow of water.
 - c. Prevent gravitational flow of water.
 - d. Used to heat a localized area.
 - e. Used to transfer heat from the water to the air.
 - f. Used to maintain system pressure.
 - g. Provides a passageway for hot water.

443. Outline the conditions that determine the flow adjustments of hot water distribution system, and differentiate between the orifice and pipe methods of adjustment.

Flow Adjustment and Balancing. A properly designed hot-water heating system is,

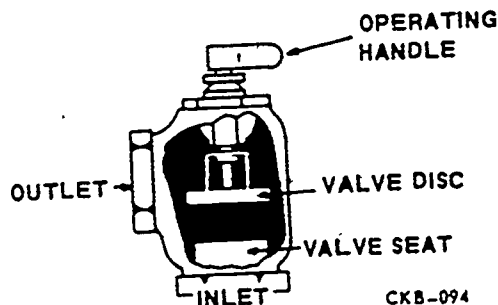


Figure 4-16. One type of flow-control valve.

to a large extent, self-adjusting. However, most systems have some way to regulate the water flow and thereby adjust the heat delivery of heating units and branch circuits during unforeseen conditions. Flow adjustment and balancing is especially important in two-pipe, direct return systems because of their inherent hydraulic unbalance. The following conditions determine the adjusting method used.

Pipe size selection. If the pipe is properly sized, a flow distribution can be established that assures pressure drop through each circuit to be the same when the system operates at design flow rate. However, since this flow control depends on the pressure drop caused by pipe friction at a certain flow, it may not be adequate for other flow conditions.

Use of orifices. Orifices can produce friction drops artificially and so balance all circuits for design flow condition. Generally, this method uses the same design principles as pipe sizing except that it creates the required friction drop by introducing an orifice instead of reducing the pipe size.

Use of throttle valves. Throttle valves provide a flexible arrangement for adjusting circuit water flow and balancing the circuit.

Balancing. To determine whether hot-water systems require balancing, measure the space temperatures with room thermometers, or determine the water temperature drops through heating unit zones with thermometers installed in the piping, or with surface contact thermometers. If the temperature drop method is used, the capacity of the heating units should be adequately matched to the heat load demand.

Procedure for system balancing. To adjust the heat distribution of a hot water heating system, proceed as follows:

1. Prepare a worksheet to record all pertinent information such as: building description, zone, date, equipment data, periodic readings, space temperature readings, and supply and return temperature of heating units or zones.
2. To eliminate outside influence, balance the system on an overcast day or at night when heat-gain conditions are minimum. However, the outside temperature should be low enough to require at least 50 percent of the systems heating capacity to maintain the desired inside temperature.
3. Place the system in service.
4. Open all valves, adjusting elements, dampers for the regulation of air circulation, etc.
5. Make sure that no automatic devices

that control the flow of water or the capacity of any unit are operating.

6. Close all doors or connecting openings between rooms.

7. Wait for the system to reach thermal equilibrium, then take a complete set of temperature readings throughout the system. (Thermal equilibrium is obtained when successive temperature readings are approximately the same.)

8. Make an initial adjustment of flow control devices according to the registered readings obtained in 7 above. If adjustment is by space temperature readings, obtain the designed indoor temperature. If the water temperature drop method is used, obtain equal temperature drops through all units or zones.

9. Take a new set of temperature readings, after a new thermal equilibrium has been established throughout the building.

10. Continue adjustments of flow regulating devices until the desired conditions are obtained.

11. When the system has been satisfactorily adjusted, mark the position of each of the flow-regulating devices (flow cocks, valves, etc.). Then, if the position of the flow-control fittings is disturbed later by accident or during emergency operations, the proper flow to heating units can be reestablished.

Exercises (443):

1. Outline the conditions that determine the methods used to adjust the flow in a hot water system.
2. Differentiate between the orifice and pipe method of adjustment.

4-4. Inspection and Maintenance of Hot-Water Heating

The maintenance of boilers is a continuing operation. For efficient operation keep the inside and outside of the boilers free from scale, slag, and soot. Keep the grates and the combustion chamber clean. When the boiler is to be closed down for the summer months, remove the manhole plates as well as the cleanout plugs, and thoroughly wash out the

boiler. Also, remove the scale and sediment that may have collected in the boiler, and wash the inside of the boiler with a stream of water from a hose. Then let the boiler dry.

During the summer overhaul, thoroughly clean the smokepipe, flues, firebox, and any part of the boiler that has been in contact with the hot gases. Corrosion and rust form to a greater degree when the boiler is idle. Grease or oil the door hinges and other similar units.

Sometimes it is necessary to replace one or more sections of a cast iron boiler because of a leaking nipple or a cracked wall. To remove the section, you loosen and remove the bolts holding it in place. Then drive wooden wedges between the damaged section and the one next to it, both at the top and bottom, to separate the sections. Repeat the procedure for removing other sections.

When steel boilers develop a leak, they may be patched by welding or riveting. When boiler flues are unserviceable, replace them.

Plugs and handholds are on the outside of the boiler so that you can reach the various parts of the boiler for cleaning. The drain valve and rod-out openings are usually at the lowest point of the boiler, so that sediment, rust, and like foreign matter can be readily washed out.

444. State the general procedures for removing, draining, and flushing a boiler.

Removing a Boiler from Service. If the complete system is to be removed from service, proceed as follows:

1. Stop the firing equipment.
2. Shut off draft dampers to permit the boiler to cool gradually.
3. Maintain water circulation through the boiler until inlet and outlet water temperatures are equalized.
4. Stop water circulators when the water in the unit has cooled; then close boiler inlet and outlet water valves.

Draining a Boiler. Never drain a boiler unless the furnace is cool enough to permit a man to enter and remain inside. This precaution prevents baking the scale inside the tubes and protects against leakage at seams or expanded joints. To drain, open all blowdown and drain valves. Make sure these valves are tagged immediately. Always insure the contents of the boiler is drained so as not to endanger personnel. Open handholes, manholes, and access parts.

Flushing. Immediately after draining, wash

interior thoroughly to prevent sludge deposits from hardening on internal surfaces, and remove all suspended solids, sediment, and loose scale. A high-pressure water hose is a good means of washing the interior. Utilize the handholes and manholes to cover as much of the internal surfaces as possible.

Exercises (444):

1. State the four main actions in removing a boiler from service.
2. When do you drain a boiler?
3. What precaution should you exercise when draining a boiler?
4. Why is a hot-water boiler flushed?
5. What boiler portions are used effectively in flushing out the boiler?

445. Define the terms "corrosion" and "scale," and explain how to inspect for corrosion and scale in a hot water boiler.

Corrosion is defined in many ways: perhaps the best being chemical or electrochemical destruction of metal. Corrosion affects metals by tending to convert metals back to their natural state as ores. Corrosion attack varies on different metals although the basic nature of corrosion is almost always the same.

Corrosion is started when two different conductive materials (known as electrodes) are immersed in a third conductive material (known as electrolyte). A voltage difference appears between the electrodes. If a connection is made between the electrodes, current will flow from one electrode to the other, resulting in a deterioration of the metal.

Scale is a coating or incrustation formed on metal surfaces. It is caused by the hardness elements in water (calcium and magnesium)

that are soluble in cold water, but become insoluble in heated water, such as that in a hot water system. These elements tend to precipitate and form the coating of metal as scale.

After the boiler has been drained, flushed, and dried, an internal inspection for corrosion and scale deposits on metal should be made. A good method is to use a mirror that has an extended handle and check all surfaces that have access through the handholes, manholes, or inspection parts. Check for scaly surfaces or metal that has a flakey appearance.

Exercises (445):

1. Define the terms "corrosion" and "scale."
2. Explain how to inspect a hot water boiler for corrosion and scale.

446. Cite general cleaning tasks of hot water boilers—cast iron and steel.

The removing of the boiler from service, draining, flushing, and corrosion and scale inspection should normally take place during the annual (summer) inspection. This annual overhaul includes inspection, cleaning, and repair. Once the inspection is complete, the cleaning tasks become important to ready the boiler for future service.

Cast Iron Boilers. Clean boiler thoroughly and remove grates (if appropriate) to facilitate access. Use wire brushes to remove all soot and dirt, and scale from flues and firebox surfaces. Clean the smokepipe. Be extremely careful not to disturb or render any controls mounted in the stack, inoperative. All hinges on doors and moving parts on regulators must be lubricated with an approved lubricant.

Steel Boilers. Clean boiler fire surfaces. Scrape flues or tubes thoroughly. Brush combustion chamber surfaces with a wire brush to remove all soot, carbon, and scale. Clean firebox corners and inside firebox sheets, outer shell and throat sheet of all bricked in boilers. Clean inner brick walls and boiler shelves, including combustion chamber, smoke breeching, and base of stack.

Exercises (446):

1. Cite three tasks in cleaning a cast iron boiler.
2. Cite any five tasks in cleaning a steel boiler.

447. State the operational tasks for filling a system with water and identify areas to inspect for leaks.

Before you proceed to fill a hot-water system, BE SURE that the following tasks have been completed. Insure that all installation, repair, and cleaning have been completed; and that piping has been tested for leaks, adequately supported and insulated, and all controls properly calibrated and preset to operate within approved limits.

To fill the system, first close all vents, open the boiler's supply main valve and return header valves. Open the inlet and outlet valves to the circulating pumps. Open all radiator valves. Then open the manual feed valves and feed water till the expansion tank is approximately one-half full. Energize the circulating pumps and establish a definite water circulation in the system. Check for noise, vibration, and abnormal temperatures in their operation.

Begin venting the radiators. Start at the lowest radiator and open vent valves until all the air is removed and water starts to flow freely. Continue this process until all the space heating units are free of air. It may be necessary to add water to the system as this routine progresses. In newly installed boilers and boilers that have had a considerable amount of internal repair, drain and refill system several times, completing all tasks mentioned above.

Probably the most important check made in filling a boiler is inspecting for leaks. Each opening such as handholes, manholes, etc. should be given a good visual inspection. Inspect all piping, both supply and return, to insure there is no wetness. Inspect the expansion tank for leakage. Inspect all radiators or space heating units. Before firing off the boiler, inspect the flues or tubes, as permissible, to insure there is no leakage. Keep a close eye on the water column of the



system to see if there is a noticeable drop in the water level.

Exercises (447):

1. State the operational tasks involved in filling a system with water.
2. Where are the various common areas that are inspected for leaks in an initial fill of a hot-water system?

448. From a list of statements select those that show hot-water boiler preliminary inspection and operational check items.

Preliminary Inspection. Before starting the system, inspect the installation carefully to be sure that the following requirements are met.

Boiler unit. All installation, repair, and clean up work is to be completed. All air and gas ducts and passages are tight and free from obstructions; gas and air control dampers are in good operating condition. All piping is tested for leaks, and insulated if necessary. Blowdown lines are properly installed and fastened, and drain valves closed; supply and return header-valves are in good operating condition. Water gage glasses on expansion tank are properly installed, with valves open; gage glasses are clearly visible from the operating floor, and lamps, if present, ready for operation. All required auxiliary equipment (such as fuel-burning, draft, feedwater, and combustion-control systems) is properly installed and ready to operate; pumps are lubricated and rotation tested. All meters, instruments, and gages are properly installed and ready for operation; pressure relief valves and limit controls are properly set and in good operating condition. Last, all access and observation doors are closed.

Space heating equipment. All installation, repair, and clean up work on radiators, convectors, pipe coils, baseboard units, etc., are completed; all units ready for operation. Fill the system, and light off the boiler, and slowly heat the system water and furnace refractory.

Initial Operation. When operating a newly filled system for the first time, heat it to a higher temperature than that anticipated for

normal operations, but not above the safe limits. This procedure expels entrained air from the system water and will help vent the system. After the system has been in operation for 2 days, open the boiler drains to eliminate the heavy core sand and similar materials that tend to flow to this low part of the system. When opening drain valves, or feeding makeup water to a hot-water heating system, keep the water flowing slowly to prevent the excessively rapid temperature changes that cause undue stresses in the boiler. After the system has operated for about 10 days, reopen the air vents and release all air from the system. Afterwards, check the system periodically for venting requirements. When starting a panel heating installation for the first time, supply water to the panels at a temperature not more than 20° F. above room temperature, or a total of 90° F. Maintain this temperature for 2 days, then progressively increase it, by about 5° F. a day, to the normal operating temperature, but do not let it exceed 140° F. After the system has been flushed and vented, do not drain it unless an emergency requires.

Water Level. When operating a hot-water system, it is very important to maintain the proper water level in the expansion tank. After the water reaches normal operating temperatures and pressure, stop the manual feed valve and use only the pressure reducing valve. The reducing valve automatically maintains the system water level. Inspect the water line in the expansion tank frequently. When the system is cold, the water level should be low enough to allow the heated water to expand. Blowdown the water, if required.

Pressure. Observe system pressure frequently. It gives information about unfavorable conditions, such as:

Low water. Below normal pressure may indicate low water.

System stoppages. Abnormally high pressures may indicate system stoppage from freezing or other causes.

Expansion tank completely full. A rise in water pressure may indicate that a closed system expansion tank is completely filled, or that the air volume in the tank is inadequate for the necessary expansion.

Failure of Relief Valve. If the relief valve fails to operate when the system pressure rises above the determined setting, shut down the boiler immediately. If the high pressure results from an excessive fuel-burning rate, the water temperature will exceed the limit control setting, and thereby shut down the boiler and start the circulators.

Check the combustion equipment.

Normal Operation. Well-designed hot-water heating systems rarely present operating difficulties, if normal temperatures and pressures are carried. If rapid fluctuation or pulsating pressures should occur, check for system leaks, stoppages, and faulty relief valve operation. The indicated pressure of a closed system may increase slightly with the increase of water temperature. Each system has its own definite increase characteristic, determined by the water capacity of the system and the size of the expansion tank. Observe and record this characteristic when the system is in perfect operating condition. Any later deviations from the established pressure may indicate that the water level is low (if pressure decreases) or that the system is stopped or plugged (if the pressure is above normal). Watch the water level in the expansion tank.

Exercises (448):

From the following statements, select those that show hot-water boiler preliminary inspection or operational check items and

indicate applicable statements by placing an X in the blank provided.

- ___ 1. Gas and air control dampers are in a fixed position.
- ___ 2. Auxiliary equipment is properly installed and ready to operate.
- ___ 3. All access and observation doors are closed.
- ___ 4. Reopen air vents after 10 days of operation to release air from the system.
- ___ 5. Use the manual feed valve for control after the water reaches normal operating pressure and temperature.
- ___ 6. Inspect the water line in the expansion tank frequently.
- ___ 7. Check the pressure, as below normal pressure may indicate low water.
- ___ 8. Check the combustion equipment.
- ___ 9. Check for fuel stoppages if rapid fluctuation or pulsating pressures occur.
- ___ 10. Check the water increase characteristic when the system is in perfect operating condition.

ANSWERS FOR EXERCISES

CHAPTER 1

Reference:

- 400 - 1. Coal-fired, oil-fired, and gas-fired.
- 400 - 2. Coal a., Gas b., Oil c.; Coal d.; Coal e.; and Oil f.
- 401 - 1. So oil is distributed evenly throughout the burner.
- 2. Lack of fuel oil.
- 3. A stamp or metal tag is attached, signifying the heater is approved by the American Gas Association.
- 4. Approximately 6 gallons of water.
- 5. It is yellow in color.
- 6. This means that all fuel going to the heater has been shut off.
- 402 - 1. The main purpose is to meter a precise amount of fuel oil to the burner pot.
- 402 - 2. The main parts are strainer, reset lever, inlet needle valve, oil temperature compensating float, manual handle; metering stem and guide assembly, safety trip-out float, and the valve inlet and outlet.
- 403 - 1. Soot is produced when there is an obstruction in the venturi tube.
- 403 - 2. It is normally yellow (caused by insufficient primary air).
- 403 - 3. Remove soot and carbon from burners, heat exchangers, and chimneys. Clean out the air inlet, storage tanks, supply lines, strainers, pilot light, and fuel oil control valve. Check wiring and lubricate blower motors.
- 404 - 1. Draft is created in a chimney because of the difference in the weight of the hot air inside the chimney and the cooler air on the outside of it. As the air on the inside is heated, it becomes lighter and rises. As this hot air rises, it is replaced by incoming cooler air. Then, as the cooler air is heated, it rises, thus creating the draft.
- 404 - 2. The chimney should be a minimum of 33 feet high.
- 405 - 1. It is used to balance the butterfly damper so the regulator will move at the slightest change in draft pressure.
- 405 - 2. It maintains a constant draft by admission of air to the flue pipe.
- 406 - 1. Should have an X.
- 406 - 2. Should not be marked.

- 406 - 3. Should have an X.
- 406 - 4. Should not be marked.
- 406 - 5. Should have an X.
- 406 - 6. Should not be marked.
- 406 - 7. Should not be marked.
- 406 - 8. Should be marked.
- 406 - 9. Should be marked.
- 406 - 10. Should be marked.
- 406 - 11. Should be marked.
- 407 - 1. Unit heaters are identified by their source of heat. The types are steam or hot water, electric, and gas- or oil-fired.
- 407 - 2. 1. Steam is b and e; 2. Electric is c and e; 3. Gas-fired is d and e; and 4. Oil-fired is a and e.
- 408 - 1. Thermostatic control of fan action or control of the heating-medium flow.
- 408 - 2. 1. Steam heater matches a, b, d, e, and i. 2. Hot-water heater matches b, d, g, and i. 3. Gas-fired heater matches c and h.
- 409 - 1. The heating medium, air distribution, and location of the unit.
- 409 - 2. Large, unpartitioned areas or commercial structures, such as garages, shops, laboratories, stores, base exchanges, and mess halls.
- 409 - 3. Electric unit heaters are used primarily for supplemental heat in housing units, sentry booths, small offices, locker rooms, and isolated rooms scattered over wide areas. Gas- and oil-fired unit heaters can be used in almost every location where steam or hot-water heaters are used.
- 410 - 1. Radiators (steam or hot water); convectors (hot water, steam or electricity); baseboard units (radiant, radiant-convactor, and finned-tube heated by hot water, steam, or electricity); finned tube units (steam or hot water); panel heating (ceiling, wall, and floor heated by hot water, electricity, and occasionally steam).
- 410 - 2. a. Radiators—heated by conduction and transfer heat to unheated areas by convection and radiation.
- b. Convectors—heats spaces by the convection principle.
- c. Finned tube units—a substantial percentage of the heat is transferred by convection.
- d. Electric ceiling panel—electrical voltage is passed through embedded cables and the heating effect to unheated areas is by radiant heat.

- 411 - 1. Should be marked.
- 411 - 2. Should not be marked.
- 411 - 3. Should be marked.
- 411 - 4. Should be marked.
- 411 - 5. Should not be marked.
- 411 - 6. Should be marked.
- 411 - 7. Should not be marked.
- 411 - 8. Should be marked.
- 411 - 9. Should be marked.

CHAPTER 2

- 412 - 1. Gun-type high pressure; gun-type low pressure; and vertical.
- 412 - 2. Horizontal rotary, atomizing, and mechanical.
- 412 - 3. 1. a, b, and d; 2. a and d; 3. c; 4. e; 5. e; and 6. f.
- 413 - 1. Should be marked.
- 413 - 2. Should not be marked.
- 413 - 3. Should be marked.
- 413 - 4. Should be marked.
- 413 - 5. Should not be marked.
- 413 - 6. Should be marked.
- 413 - 7. Should be marked.
- 413 - 8. Should not be marked.
- 413 - 9. Should be marked.
- 414 - 1. The process is the same as for the two-stage fuel unit, except fuel flows by gravity from the tank to the pump instead of being drawn by a pumping unit.
- 414 - 2. The first stage pump draws fuel from the storage tank and discharges it to the purging chamber, where it is picked up by the second stage pump. The fuel is forced into a pressure chamber where enough pressure is built up to operate a hydraulically motivated metering piston to open the shut off valve and allow oil to flow to the nozzle where it is dispersed to the combustion chamber.
- 415 - 1. Gas pilot flames, electrical, and separate domestic oil burners are methods used to ignite the fuel oil used in fuel oil burners.
- 415 - 2. Ignition takes place when a pair of electrodes, together with the transformer, set up an electrical arc which ignites the oil being pumped into a combustion chamber.
- 416 - 1. 1. b, 2. d, 3. f, 4. h, 5. g, 6. c, 7. e, and 8. a.
- 417 - 1. Manometer and Bourdon gage.
- 417 - 2. They are classified according to pressure or how each mixes the gas and air together.
- 417 - 3. Bunsen, Radiant, Upshot, and Inshot.
- 418 - 1. Manifold, spud, orifice, venturi tube, manual shutoff valve, pressure regulator, solenoid gas valve, diaphragm valve, pilot light, thermocouple, thermocouple control relay, and the thermopile.
- 418 - 2. You should have marked a, c, f, g, and h.
- 419 - 1. Inspect, clean, repair, or replace the orifice; inspect for and clean all soot and carbon deposits; adjust for a proper air-gas mix-

ture; and inspect and repair burner refractory.

- 419 - 2. Keep the total air flow adjusted. Keep the gas-air flow ratio maintained at about 0.10 inches of water (negative). Control the firing rate to the pilot burners for a slightly yellow flame. Maintain the main burner flame to a blue color with a yellow tip. Maintain the pilot flame to a blue color without a yellow tip.

CHAPTER 3

- 420 - 1. The furnaces are made of cast iron or steel.
- 420 - 2. It provides a space through which air is circulated, by natural or forced convection.
- 420 - 3. Gas-tight seals are made with liberal use of furnace cement, asbestos rope, or both.
- 420 - 4. Ash pit or firepot, a feed or combustion chamber, a radiator section or heat exchanger, and a casing.
- 421 - 1. Loop system, radial system, crawl space system, and inside wall delivery system.
- 421 - 2. The loop has ducts extending completely around the perimeter of the building in a continuous loop. The ducts are supplied with heat from the plenum chamber by radial ducts. The radial ducts running spokedwise from the plenum chamber to each register. The crawlspace uses an entire space below the floor as a heat dispersing supply area; and the inside wall delivery uses ducts which supply heat from the plenum chamber to the registers of rooms located on an inside wall, either high at ceiling level or low at floor level.
- 421 - 3. A. F; B. G; C. F; D. G; E. F; F. G.
- 422 - 1. Should be marked.
- 422 - 2. Should not be marked.
- 422 - 3. Should be marked.
- 422 - 4. Should not be marked.
- 422 - 5. Should be marked.
- 422 - 6. Should be marked.
- 422 - 7. Should not be marked.
- 422 - 8. Should be marked.
- 422 - 9. Should be marked.
- 422 - 10. Should not be marked.
- 422 - 11. Should be marked.
- 423 - 1. A damper.
- 423 - 2. Make sure the ducts are reasonably air tight.
- 423 - 3. Equip ducts with dampers, shutoffs, and registers.
- 423 - 4. The large end or the largest cross-sectional area.
- 424 - 1. The possession of a proper set of tools.
- 424 - 2. Use either a sharpened toothpick or a brush bristle.
- 424 - 3. Install a new nozzle.
- 424 - 4. Annually, remove and clean the burner, check for gas leaks, adjust the primary air, and tighten all electrical connections.
- 425 - 1. Remove the various bolts that connect the complete burner to the furnace, disconnect and remove the wiring from the motor,

- transformer, etc., and remove the burner. Insert the new burner, connect the wiring and rebolt to furnace. Make minor frame and air adjustments, if necessary, and the furnace is ready for operation.
- 425 - 2. Always insure the replacement burner is the correct size, type, and model.
- 425 - 3. Normally lifting the gas burner out and inserting a new one of the proper type is all that is involved. It is not usually necessary to remove any bolts or screws.
- 426 - 1. Centrifugal or squirrel cage.
- 426 - 2. The blades can be either curved backward, forward, or plain radial.
- 426 - 3. The backward curved blade.
- 426 - 4. Direct-drive and belt-drive.
- 427 - 1. Antifriction, sleeve, and thrust.
- 427 - 2. 1. *b. c.* and *g*; 2. *a*; 3. *d* and *e*; 4. *f*; and 5. *h*.
- 428 - 1. Malfunctions caused by the motor, bearings, belts, or improper alignment.
- 428 - 2. Disconnect the motor wiring, remove the bolts that stabilize the blower, insert new fan, and reconnect bolts and wiring.
- 429 - 1. A large type (mill) pulley and a small type (sheave) pulley.
- 429 - 2. V-belts are generally used, but flat belts are also being used.
- 429 - 3. A rubber bushed coupling and a gear type coupling.
- 429 - 4. Move the flanges closer together or farther apart by loosening the setscrew on the moveable flange and screwing the flange in or out as desired and retighten the setscrew.
- 429 - 5. Loosen the motor from its base and shift it closer to the blower. This allows a new belt, which is shorter in length (has not been stretched), to be easily installed. Realign and adjust and retighten the motor to its base.
- 429 - 6. Replace both belts because a new belt cannot be adjusted properly if it is used with an old stretched belt.
- 429 - 7. The gear type pulley requires frequent cleaning and lubrication.
- 430 - 1. Cleanable and throwaway.
- 430 - 2. At least once a month.
- 430 - 3. Clean with hot water, steam, or by an oil and grease cutting solution.
- 430 - 4. It must be recoated with a viscous substance (oil).
- 431 - 1. Deformation, leakage of air and heat, accumulations of lint and dirt, and condensation of oil or water vapors.
- 431 - 2. By washing or vacuum cleaning the interior of the duct.
- 432 - 1. Face and bypass damper, air intake damper, volume damper, and recirculating damper.
- 432 - 2. Bent shafts, binding of blades or operating mechanism, bent rods or levers, and air leakage.
- 433 - 1. *a* The thermostat transmits an electrical signal to other control devices by making or breaking electrical contacts within the

- thermostat itself for controlling room or building temperature.
- b.* Controls the operation of the fire so that the temperature of the heating plant will never exceed safe operating limits and limits temperature of the heating system to provide regulated temperature in the building.
- c.* Controls the operation of the air supply fan or blower in a forced-warm-air heating system.
- d.* Controls the temperature of the heating plant so it will never exceed safe operating limits along with operating the air supply fan or blower in the same way as if they were used individually.
- e.* A controlled water supply to a pan usually installed in the warm-air plenum chamber so the hot dry air from the furnace absorbs (evaporates) the water from the pan, thereby, increasing its relative humidity.
- f.* Sends electrical signals to operate dampers, valves, or other devices that control humidity.

- 433 - 2. 1. *d*; 2. *a*; 3. *a*; 4. *a*; and 5. *b*.

CHAPTER 4

- 434 - 1. LTW is 100° F. to 220° F. and MTW is 220° F. to 300° F.
- 434 - 2. The rate of heat conduction through the metal in the boiler tubes and the rate of water circulation in the boiler,
- 435 - 1. Round cast iron, square section cast iron, and steel type boilers.
- 435 - 2. A cast iron boiler is constructed of several sections joined together by pipes called header connections while steel boilers are composed of two sections joined together by welding or riveting.
- 435 - 3. The type of fuel used.
- 435 - 4. Rods and nuts hold the section firmly together.
- 435 - 5. The sections are usually small enough to be taken through normal sized doors, making installation or replacement easier.
- 436 - 1. A major factor for hot-water boiler installation is to insure it has a proper foundation.
- 436 - 2. The top surface should be level; the surface should be poured separately from the floor; and it should have sufficient width, depth, and height.
- 437 - 1. To allow a dangerous buildup of pressure to escape from the boiler.
- 437 - 2. When the pressure in a steam increases to a predetermined level, it unseats a spring loaded valve to release pressure until it drops to a safe level. Corrosion.
- 437 - 3. An accurate pressure gage. A person certified to make such adjustments.
- 437 - 4. Check for valve deterioration and inadequate support of exhaust piping.
- 437 - 5. Increase the pressure to a point that operates the valve or hand blow the valve on a monthly basis.

- 438 - 1. The aquastat prevents steaming of the boiler water and reduces operating costs.
- 438 - 2. Insuring that it is mounted level.
- 439 - 1. This valve automatically keeps the system supplied with water at a predetermined safe pressure.
- 439 - 2. The valve stem, valve seat, and stuffing box.
- 439 - 3. Either change or regrind the seat.
- 440 - 1. There are open tanks and closed tanks.
- 440 - 2. a. X b. c. X d. X e. f. and X g.
- 441 - 1. Should *not* be marked.
- 441 - 2. Should be marked.
- 441 - 3. Should *not* be marked.
- 441 - 4. Should be marked.
- 441 - 5. Should be marked.
- 441 - 6. Should be marked.
- 441 - 7. Should *not* be marked.
- 441 - 8. Should be marked.
- 441 - 9. Should *not* be marked.
- 441 - 10. Should *not* be marked.
- 441 - 11. Should be marked.
- 442 - 1. g 1. e 2. d 3. b 4. c 5. and a 6.
- 443 - 1. a. Correct pipe size.
b. The orifices.
c. The use of throttle valves.
- 443 - 2. Orifices produce friction drop while pipe sizing reduces the pipe size.
- 444 - 1. (1) Stop the firing equipment.
(2) Shut off the draft.
(3) Maintain water circulation until inlet and outlet temperatures are equalized.
(4) Stop circulators when boiler water has cooled.
- 444 - 2. When the furnace portion is cool enough to permit an individual to enter and remain inside.
- 444 - 3. Tag all drain valves and insure boiler

- contents do not endanger personnel when being drained.
- 444 - 4. To remove suspended solids, sediment, and loose scale.
- 444 - 5. The handholes and manholes.
- 445 - 1. Corrosion is the chemical or electrochemical destruction of metal. Scale is a coating or incrustation formed on metal surfaces.
- 445 - 2. Use a mirror in the access ports and look for sealed surfaces, or metal with a flakey appearance.
- 446 - 1. Remove soot, dirt, and scale from flue and firebox surfaces; clean the smokepipe; and lubricate door hinges and moveable parts of regulators.
- 446 - 2. Clean flues and tubes; combustion surfaces; complete firebox; inner brick walls; boiler shelves; breeching; and base of stack.
- 447 - 1. First, close all system vents, open supply or return valves, open inlet and outlet circulator valves, and open all radiator valves. Next, open the manual feedwater valve and leave it open until the expansion tank is half full. Start the circulating pumps. Vent the radiators and last, vent the system.
- 447 - 2. Inspect for leaks at the handhole and manhole openings, supply and return piping, expansion tank, all radiators or space-heating units, and the tube or flue areas.
- 448 - 1. Should *not* be marked.
- 448 - 2. Should be marked.
- 448 - 3. Should be marked.
- 448 - 4. Should be marked.
- 448 - 5. Should *not* be marked.
- 448 - 6. Should be marked.
- 448 - 7. Should be marked.
- 448 - 8. Should be marked.
- 448 - 9. Should *not* be marked.
- 448 - 10. Should be marked.



STOP -

1. MATCH ANSWER SHEET TO THIS EXERCISE NUMBER.

2. USE NUMBER 1 OR NUMBER 2 PENCIL.

54730 03 '24

EXTENSION COURSE INSTITUTE
VOLUME REVIEW EXERCISE

HEATING SYSTEMS

Carefully read the following:

DO'S:

1. Check the "course," "volume," and "form" numbers from the answer sheet address tab against the "VRE answer sheet identification number" in the righthand column of the shipping list. If numbers do not match, take action to return the answer sheet and the shipping list to ECI immediately with a note of explanation.
2. Note that numerical sequence on answer sheet alternates across from column to column.
3. Use a medium sharp #1 or #2 black lead pencil for marking answer sheet.
4. Circle the correct answer in this test booklet. After you are sure of your answers, transfer them to the answer sheet. If you *have* to change an answer on the answer sheet, be sure that the erasure is complete. Use a clean eraser. But try to avoid any erasure on the answer sheet if at all possible.
5. Take action to return entire answer sheet to ECI.
6. Keep Volume Review Exercise booklet for review and reference.
7. If *mandatorily* enrolled student, process questions or comments through your unit trainer or OJT supervisor.
If *voluntarily* enrolled student, send questions or comments to ECI on ECI Form 17.

DON'TS:

1. Don't use answer sheets other than one furnished specifically for each review exercise.
2. Don't mark on the answer sheet except to fill in marking blocks. Double marks or excessive markings which overflow marking blocks will register as errors.
3. Don't fold, spindle, staple, tape, or mutilate the answer sheet.
4. Don't use ink or any marking other than a #1 or #2 black lead pencil.

NOTE: NUMBERED LEARNING OBJECTIVE REFERENCES ARE USED ON THE VOLUME REVIEW EXERCISE. In parenthesis after each item number on the VRE is the *Learning Objective Number* where the answer to that item can be located. When answering the items on the VRE, refer to the *Learning Objectives* indicated by these *Numbers*. The VRE results will be sent to you on a postcard which will list the *actual VRE items you missed*. Go to the VRE booklet and locate the *Learning Objective Numbers* for the items missed. Go to the text and carefully review the areas covered by these references. Review the entire VRE again before you take the closed-book Course Examination.



Multiple Choice

1. (400) The basic categories of space heaters are
 - a. radiation and convection types.
 - b. radiation, reradiation, and convection types.
 - c. coal, oil, and gas types.
 - d. cannon and magazine types.

2. (400) What is most likely to cause the grate to burn out in a cannon-type space heater?
 - a. Wrong type of coal.
 - b. Ash buildup.
 - c. Flu stoppage.
 - d. Dirty fuel.

3. (400) The type of fuel normally used in oil-fired space heaters is
 - a. gasoline.
 - b. butane LP.
 - c. fuel oil, No. 1 weight.
 - d. fuel oil, No. 4 weight.

4. (400) The most common oil burner space heater is the
 - a. pot type.
 - b. sleeve type.
 - c. cannon type.
 - d. magazine type.

5. (401) The line used to convey gas to the heater is usually made of
 - a. copper.
 - b. galvanized iron.
 - c. steel pipe.
 - d. black iron.

6. (401) The unit used to feed a precise amount of fuel oil to the burner pot is called
 - a. a metering valve.
 - b. a venturi tube.
 - c. a pressure regulator.
 - d. a manifold.

7. (402) The manual safety control incorporated into the oil control valve is the
 - a. reset lever.
 - b. inlet needle valve.
 - c. safety tripout float.
 - d. oil temperature compensating float.

8. (403) Preventive maintenance of oil space heaters consists mostly of
 - a. cleaning only.
 - b. cleaning and adjustment.
 - c. cleaning, adjustment, and repair of parts.
 - d. cleaning, adjustment, repair, and replacement of parts.

9. (404) The "draft" of a chimney is best described as
 - a. the barometric difference between the bottom and the top of the chimney.
 - b. hot air rising and being replaced by cold air.
 - c. the convection curve of the heat differential.
 - d. the heated air being heavier than the cold air.

10. (404) How tall should a chimney be?
 - a. A minimum of 10 feet.
 - b. A minimum of 25 feet.
 - c. Extends 3 feet above the roof's highest point.
 - d. Six feet higher than any surrounding structure.

- 11. (405) The counterweight for a space heater draft regulator is not required
 - a. in a vertical stack.
 - b. in a 450 stack.
 - c. if the stack is more than 25 feet high.
 - d. in a horizontal stack.

- 12. (405) What is the purpose of the regulator on a smokestack?
 - a. To govern fuel flow.
 - b. To maintain a constant draft.
 - c. To close off primary air.
 - d. To help create a down draft.

- 13. (407) Unit heaters are classified by their
 - a. size.
 - b. fan type.
 - c. heating capacity.
 - d. source of heat.

- 14. (407) Unit steam heaters are rated
 - a. at psig entering steam and 60° F. entering air.
 - b. in Btu per hour above 60° F.
 - c. by input and output.
 - d. in Btu hours.

- 15. (407) What determines the amount of air that is recirculated by a unit heater?
 - a. The stack damper.
 - b. The damper at the cold air inlet.
 - c. The damper at the discharge outlet.
 - d. The position of the chimney damper.

- 16. (408) To provide for rapid warmup in a unit heater, the heating valve should be wide open and the
 - a. stack damper closed.
 - b. inlet damper closed.
 - c. outlet damper closed.
 - d. stack damper open.

- 17. (409) For best results, heat exchangers should be located
 - a. where heat losses occur.
 - b. along inside walls.
 - c. along outside walls.
 - d. at floor level.

- 18. (410) The principle of convection heating is that
 - a. air is warmed by contact.
 - b. cold air rises.
 - c. hot air rises.
 - d. cold air is replaced by hot air.

- 19. (410) The basic types of baseboard heaters are
 - a. radiant, radiant-convactor, and finned tube.
 - b. free-standing, wall-hung, or recessed.
 - c. oil-fired, gas-fired, and coal-fired.
 - d. column, small tube, and wall.

- 20. (411) How often should heat exchangers be inspected?
 - a. Weekly.
 - b. Monthly.
 - c. Semiannually.
 - d. Annually.



- 21. (411) The "start of heating season" check should cover
 - a. voltage, steam pressure, and corrosion.
 - b. grill condition, hot spots, and condensate.
 - c. burner condition, paint, and internal corrosion.
 - d. valve and regulator operation, steam traps, and air vents.

- 22. (412) The conversion of a liquid fuel to a gaseous fuel is called
 - a. atomization.
 - b. vaporization.
 - c. gaseousization.
 - d. combustion.

- 23. (412) The basic classifications for oil burners are
 - a. gun-type high-pressure, gun-type low-pressure, and vertical oil burners.
 - b. large and small burners.
 - c. horizontal rotary, atomizing, and mechanical burners.
 - d. domestic and industrial.

- 24. (412) The most popular domestic oil burner is the
 - a. high-pressure gun type.
 - b. low-pressure gun type.
 - c. vertical type.
 - d. horizontal-rotary type.

- 25. (413) Major factors to be considered when replacing an oil burner motor are the
 - a. manufacturer and available voltage.
 - b. cost, current draw, and enclosure.
 - c. rotation ~~direction~~, rpm, and mounting.
 - d. voltage available, current draw, and bearing type.

- 26. (413) The voltage necessary to ignite fuel in the oil burner is provided by
 - a. a step-up transformer.
 - b. ignition electrodes.
 - c. a ballast.
 - d. a spark plug.

- 27. (413) What replaces the first stage of a two-stage pumping unit in a single-stage unit?
 - a. Air pressure.
 - b. Centrifugal force.
 - c. Gravity.
 - d. Hydraulic pressure.

- 28. (414) What should be the pressure on the oil in the pressure chamber of a low-pressure atomizing gun-type oil burner?
 - a. 5 to 10 pounds.
 - b. 10 to 15 pounds.
 - c. 15 to 25 pounds.
 - d. 25 to 35 pounds.

- 29. (415) What is the purpose of the electrode assembly in an oil burner ignition system?
 - a. To provide a high voltage.
 - b. To provide a high current.
 - c. To provide an arc gap.
 - d. To provide high electrical power.

- 30. (416) The prime source of information for operating oil burners is the procedures in
 - a. Air Force technical orders.
 - b. the manufacturer's instructions.
 - c. Air Force manuals.
 - d. locally prepared checklists.



31. (416) After an oil burner has been lighted and the flame visually adjusted, what else should be done to assure proper combustion?
- a. Oil flow should be checked.
 - b. Air flow should be adjusted.
 - c. Check with a flue-gas analyzer.
 - d. Check soot buildup at the chimney stack switch.
32. (417) The pressure indicator in a gas-burning system that reads directly in pounds per square inch is the
- a. Bourdon gage.
 - b. galvanometer.
 - c. dynamometer.
 - d. manometer.
33. (418) The component of the gas burner fuel assembly that feeds gas to the spud is called
- a. a pressure regulator.
 - b. a manifold.
 - c. an orifice.
 - d. a venturi tube.
34. (418) The gas pressure regulators used in domestic gas-heating systems are normally what type?
- a. Bourdon tube type.
 - b. Spring check valve.
 - c. Aneroid.
 - d. Diaphragm.
35. (418) Thermocouples will produce
- a. voltage when heated.
 - b. current when cooled.
 - c. current when heated.
 - d. voltage when cooled.
36. (419) The shape of the flame of a gas burner is controlled by adjusting the
- a. dampers.
 - b. fan speed.
 - c. orifices.
 - d. air register.
37. (419) When adjusted properly, the color of the main burner flame in a gas furnace should be
- a. red, yellow tip.
 - b. blue.
 - c. red, blue tip.
 - d. blue, yellow tip.
38. (419) The part most likely to cause a gas heater to be inoperative is the
- a. pressure regulator.
 - b. stack switch.
 - c. pilot light.
 - d. gas manifold orifice.
39. (419) Lack of complete combustion in a gas burner pilot will result in
- a. buildup of carbon and soot.
 - b. restricted gas flow.
 - c. a blue flame.
 - d. burned orifices.
40. (420) The part of a furnace which forms the space through which the air is circulated is called the
- a. combustion chamber.
 - b. duct.
 - c. heat exchanger.
 - d. casing.
41. (420) Cast iron furnace sections are made gas-tight by
- a. welding.
 - b. bolting the sections together.
 - c. using cement.
 - d. using furnace cement and asbestos rope.



- 42. (420) When the heat is transferred directly from the hot combustion gases to the air which circulates around the furnace and radiator, the furnace is a
 - a. direct-fired furnace.
 - b. indirect-fired furnace.
 - c. horizontal-fired furnace.
 - d. vertical-fired furnace.

- 43. (421) The most common cause of unsatisfactory operation in a gravity warm-air furnace is
 - a. the clearance between the bonnet and ceiling.
 - b. insufficient duct area.
 - c. the upward pitch of the hot air duct.
 - d. the heat loss from the building.

- 44. (421) In a perimeter loop air distribution system, the maximum number of diffusers that can be placed in a single section of loop duct between any two feeders is
 - a. two.
 - b. three.
 - c. four.
 - d. five.

- 45. (421) In a radial perimeter heating system, the air velocity at the end of the throw of high-side wall registers should be around
 - a. 20 feet per minute.
 - b. 30 feet per minute.
 - c. 50 feet per minute.
 - d. 75 feet per minute.

- 46. (421) Which of the following perimeter air systems often uses high initial air velocities because of the short length of throw?
 - a. Inside-wall delivery systems with annular diffusers.
 - b. Radial systems with 360° annular diffusers.
 - c. Loop systems with 180° diffusers.
 - d. Ceiling delivery systems with annular diffusers.

- 47. (422) On new furnace installations, the heat exchanger should be checked for leaks or cracks before installing the
 - a. radiator.
 - b. baffles.
 - c. casing.
 - d. bonnet.

- 48. (422) How far from the outlet of the furnace should the check draft in the smokepipe of a coal furnace be installed?
 - a. 10 to 12 inches.
 - b. 14 to 18 inches.
 - c. 18 to 36 inches.
 - d. 36 inches or over.

- 49. (422) If the furnace room is to be adequately ventilated to supply free air for combustion, floor or ceiling openings must have a minimum area of at least
 - a. 100 square inches.
 - b. 150 square inches.
 - c. 200 square inches.
 - d. 250 square inches.

- 50. (423) The purpose of covering the air ducts in a warm-air heating system with a thin layer of asbestos paper is to
 - a. reduce heat loss through convection.
 - b. reduce heat loss through radiation.
 - c. comply with safety regulations to reduce accidents.
 - d. protect the ducts against corrosion.



- 51. (423) After the warm-air furnace is installed and operating, the next step is to
 - a. close off some of the dampers.
 - b. balance the fuel-air ratio.
 - c. insulate all warm air ducts.
 - d. adjust the dampers to distribute the air evenly.

- 52. (424) The burner, pilot, and thermocouple of a gas-heating system should be removed and cleaned at least
 - a. once per month when the system is operating.
 - b. three times a year.
 - c. twice a year.
 - d. once a year.

- 53. (425) The most important requirement when replacing a burner in a warm-air furnace is to
 - a. tighten all bolts an even amount.
 - b. make sure the correct burner is being used as the replacement.
 - c. use a new gasket for the new burner.
 - d. make sure the components have been checked for safe operation.

- 54. (427) In a forced-air system, a thumping noise in the blower is usually an indication of
 - a. a worn out bearing.
 - b. a bearing out of alignment.
 - c. loose belts.
 - d. too much end play.

- 55. (427) Belt-driven fan motors in warm-air systems require lubrication at the time of installation and at least every
 - a. 3 months thereafter.
 - b. 4 months thereafter.
 - c. 6 months thereafter.
 - d. year thereafter.

- 56. (429) The types of drive couplings used in warm-air heating systems are the
 - a. universal and rubber bushing coupling.
 - b. flange and universal coupling.
 - c. gear and hydraulic coupling.
 - d. rubber bushing and gear coupling.

- 57. (429) Before increasing the speed of a centrifugal blower system fan, you must first determine the
 - a. drive ratio.
 - b. amperage draw and compare it to the data plate "specs."
 - c. design of the system.
 - d. maximum speed of the fan.

- 58. (429) A straight-edge or tight line is used to check
 - a. the sheave alignment.
 - b. the belt tension.
 - c. the motor alignment.
 - d. all of the above.

59. (430) The two types of filters used in heating systems are
- steel and wool.
 - the cleanable and throwaway.
 - viscous and fiberglass.
 - animal hair and steel wool.
60. (431) To reduce noise from air passing through the duct, a
- muffler is placed 10 feet from the fan discharge.
 - noise absorbing material is placed at each outlet.
 - sound absorbing material is placed on one interior side of the duct.
 - sound absorbing material is placed on the four outside walls of the duct.
61. (431) Air distribution ducts are inspected for accumulations of dirt and lint
- periodically.
 - yearly.
 - every 4 months.
 - at the beginning of the heating season.
62. (432) The most common defect that causes erratic air duct damper operation is
- bent shafts.
 - the thermostat.
 - binding blades.
 - bent rods or levers.
63. (433) When the contacts of a thermostat become dirty or oxidized, they should be cleaned with
- a hard-finish paper.
 - a mixture of alcohol and water.
 - a wire brush and soap.
 - an emery cloth and finished with jeweler's rouge.
64. (433) The secondary function of the limit control on warm-air systems is
- safety.
 - to provide better temperature regulation within the building.
 - to provide better changes in the air temperature.
 - to limit the amount of fuel being fed to the furnace.
65. (433) In a forced-air heat system, the fan switch is installed in the
- bonnet.
 - return duct.
 - flue.
 - primary combustion chamber.
66. (433) On a warm-air furnace, if the humidifier water valve sticks open, the
- heating section may crack.
 - furnace will shut down.
 - main control closes the solenoid valve.
 - humidity may reach 100 percent RH.
67. (433) For proper operation, the humidistat for a warm-air furnace must be
- located outside of the main air stream.
 - cleaned monthly while in service.
 - located in the return air stream.
 - clean and encased at all times.

68. (434) Which listed temperatures represent the span of a low temperature hot-water heating system?
- a. 75° F. to 100° F.
 - b. 100° F. to 220° F.
 - c. 220° F. to 300° F.
 - d. 300° F. to 450° F.
69. (434) What unit(s) in a hot-water heating system maintain proper pressure and prevent steam formation?
- a. The expansion tank.
 - b. The radiators.
 - c. The large return pipes.
 - d. The pressure pump.
70. (434) The baffles in hot-water heating boilers are used to
- a. detain the hot water as long as possible.
 - b. direct the flow of water through the boiler.
 - c. control the temperature in the chimney.
 - d. retain the hot gases as long as possible.
71. (435) When the sections of a square cast iron boiler are connected by push nipples, the sections are held together by
- a. welded bands.
 - b. straps and bands.
 - c. rods and nuts.
 - d. welded rods.
72. (435) Heating boilers having a separate base not containing water require a floor of
- a. wood.
 - b. asphalt.
 - c. sheetrock.
 - d. fireproof construction.
73. (435) A disadvantage of cast iron hot-water heating boilers is the
- a. danger of component cracking or breaking when improperly handled or fired.
 - b. inability of being assembled inside the boilerroom.
 - c. need for special equipment to assemble or disassemble the units.
 - d. ability to resist the chemical action of corrosive agents.
74. (436) The top surface of the hot-water heating system foundation should be level to insure proper
- a. heating of the water.
 - b. flow of the water.
 - c. alignment of the boiler sections.
 - d. settling of the foundation.
75. (437) How often should the safety relief valve on a boiler be checked for accuracy of setting?
- a. Once each month.
 - b. Twice each month.
 - c. Once each year.
 - d. Twice each year.
76. (437) The aquastat on a hot-water boiler installation is used to prevent
- a. excessive flow of boiler water.
 - b. flameouts in the system.
 - c. steaming of boiler water.
 - d. excessive humidity in the system.



- 77. (439) In a closed hot-water system, a factory setting of 12 psi pressure on the reducing valve is equal to a static head of
 - a. 27.6 feet of water.
 - b. 30.6 feet of water.
 - c. 37.6 feet of water.
 - d. 40.6 feet of water.

- 78. (439) In a closed hot-water system, how often should the pressure reducing valve be dismantled, cleaned, and inspected for wear?
 - a. Only once a month.
 - b. Once a year; more often if required.
 - c. Only when unit stops operating.
 - d. Once every 2 years.

- 79. (440) If the capacity of a boiler is 3000 gallons, and the water is heated to 200° F., the capacity of the expansion tank should be
 - a. 30 gallons.
 - b. 60 gallons.
 - c. 120 gallons.
 - d. 240 gallons.

- 80. (440) If a hot-water heating system can operate over a wide range of temperatures and pressures, what type of system is it?
 - a. Balanced-tank system.
 - b. Closed-tank system.
 - c. Open-tank system.
 - d. Vented-tank system.

- 81. (441) In the two-pipe, open-tank gravity hot-water system, the radiators are connected in
 - a. series with the mains.
 - b. series with each other.
 - c. parallel with each other.
 - d. parallel with the mains.

- 82. (441) A two-pipe, hot-water system that has good flow distribution and natural system balance without the aid of additional valves or orifices is known as a
 - a. series-loop system.
 - b. direct-return system.
 - c. reversed-return system.
 - d. high-speed return system.

- 83. (442) The water circulating pump in a forced hot-water heating system is located
 - a. in the return line near the boiler.
 - b. just before the first radiator.
 - c. just after the last radiator.
 - d. in the supply line near the boiler.

- 84. (443) Why should hot-water distribution systems be balanced on an overcast day or at night?
 - a. To eliminate variations in pressure.
 - b. To eliminate outside influence.
 - c. There is less demand for heat.
 - d. There is less variation in control units.

- 85. (444) During cleaning maintenance, to prevent the hardening of sludge deposits on the internal surfaces of the boiler, thoroughly wash the interior
 - a. as soon as the boiler is dry.
 - b. before boiler is completely drained.
 - c. immediately after draining.
 - d. no sooner than 12 hours after draining.



86. (446) What units in the smokepipe of the cast iron boiler system must not be disturbed during cleaning activities?
- a. Control.
 - b. Surface.
 - c. Base of stack.
 - d. Outer shell.
87. (447) When filling a hot-water heating system, what is the first step to be accomplished?
- a. Open all vents.
 - b. Close valves to radiators.
 - c. Fill expansion tank.
 - d. Close all vents.
88. (447) What is the most important check made when filling a hot-water heating system?
- a. Venting the system.
 - b. Operation of the valves.
 - c. Inspection for leaks.
 - d. Checks for noise.
89. (448) If you are operating a newly filled hot-water heating system for the first time, how long should the system be operated before draining sand and similar materials from the system?
- a. 1 day.
 - b. 2 days.
 - c. 3 days.
 - d. 4 days.
90. (448) In a hot-water heating system, what unit is used to automatically maintain the system water level?
- a. Safety relief valve.
 - b. Manual feed valve.
 - c. Expansion tank.
 - d. Pressure reducing valve.

333

54730 04 7411

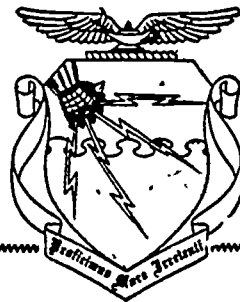
CDC 54730

APPRENTICE HEATING SYSTEMS SPECIALIST

(AFSCs 54730 and 54730A)

Volume 4

Central Heat Plants



11-1

Extension Course Institute

Air University

339

335

Preface

THIS FOURTH volume of CDC 54730, *Apprentice Heating Systems Specialist*, contains five chapters which provide you with much knowledge needed for the operation and maintenance of central heating plants.

The first chapter deals with high temperature water (HTW). The discussions include types of generators, components, systems, and the operation and maintenance procedures needed for a high temperature water central plant.

The second and third chapters cover the operation and maintenance of steamplants. This discussion includes types of boilers and their components, auxiliary equipment necessary for proper operation, and the maintenance factors involved.

The fourth and fifth chapters discuss external and internal water treatments. These include water softeners, chemicals, equipment, etc.

It is recommended that you carefully study the illustrations and tables. Logs for both high temperature water and steam heating plants are included.

If you have questions on the accuracy or currency of the subject matter of this text, or recommendations for its improvement, send them to Tech Tng Cen/TTOC, Sheppard AFB TX 76311.

If you have questions on course enrollment or administration, or any of ECI's instructional aids (Your Key to Career Development, Behavioral Objective Exercises, Volume Review Exercise, and Course Examination), consult your education officer, training officer, or NCO, as appropriate. If he can't answer your questions, send them to ECI, Gunter AFS AL 36118, preferably on ECI Form 17, Student Request for Assistance.

This volume is valued at 36 hours (12 points).

Material in this volume is technically accurate, adequate, and current as of June 1974.

Contents

	<i>Page</i>
<i>Preface</i>	<i>iii</i>
Chapter	
1 High Temperature Water	1
2 Steamplant Operation	29
3 Steamplant Maintenance	93
4 External Water Treatment	131
5 Internal Water Treatment	150
<i>Answers for Exercises</i>	175



NOTE: In this volume, the subject matter is developed by a series of Learning Objectives. Each of these carries a 3-digit number and is in boldface type. Each sets a learning goal for you. The text that follows the objective gives you the information you need to reach that goal. The exercises following the information give you a check on your achievement. When you complete them, see if your answers match those in the back of this volume. If your response to an exercise is incorrect, review the objective and its text.

High Temperature Water

HIGH TEMPERATURE water (HTW) is the latest newcomer to the heating field. As such, it is slowly emerging from the shroud of mystery which has surrounded it for many years. Most of the mystery is due to the lack of reliable reference material and to the lack of actual experience. As a heating systems specialist, it is your responsibility to learn the operation and maintenance procedures of HTW plants and distribution systems. This can be accomplished by mastering the learning objectives in this chapter.

1-1. Theory of Operation

Operation of an HTW system is steeped in theory; theory which has been applied and proven. This section will describe the operating characteristics and identify components of HTW systems.

600. Specify the operating principles and characteristics of HTW systems, and identify specific components of these systems.

Operating Characteristics. High temperature water (HTW) is water heated above the boiling point (212° F. under normal atmospheric pressure) which is 14.7 pounds per square inch, absolute (psia). If we apply pressure to the water, we will raise the temperature at which water will boil. Table 1-1 shows the pressure and temperature relationship or the saturation temperature of water. Water that is 100 percent saturated cannot absorb any more heat without changing to steam. If we have water at 212° F., under normal atmospheric pressure, it will begin to boil, and we will have a mixture of steam and water. However, if we heat this

same water to 213° F., we no longer have water, we have steam or vapor. In the Air Force, the operating range for HTW is 350° F. and above. Most HTW plants in the Air Force operate between 350° F. and 400° F. Referring again to table 1-1, you will see that these temperatures require absolute pressures between 134.63 to 247.31 psia to keep the water in a liquid state. United States Air Force/Civil Engineering (USAF/PRE) must approve all designs for HTW generators that operate at temperatures above 400° F.

Efficiency. HTW has proven itself as a highly successful means of heating. It is approximately 30 times as efficient as steam under similar conditions. This high rate of efficiency is easily understood when a few basic facts are reviewed. You remember that after water is heated to 212° F., it still requires 970 British thermal units (Btus) per pound before it can flash to steam. This additional heat does not increase the temperature of the steam. It is used on the change of state process (in this case, liquid to vapor). If we apply additional heat to pressurized water, we could have water at a temperature of approximately 705° F. Water, especially hot water, can flow through a pipe more easily than steam. This is because the condensate in the steam lines impedes or slows down the flow of steam. Water, on the other hand, films or coats the inside walls of pipes, and assists the flow through the lines. Another reason for the great difference in efficiency is that steam must release its 970 Btu/pound before it can be returned to the central heating plant and fed back into the boiler. The steam boiler must then reapply an additional 970 Btus for each pound of water. HTW does not change state at any time,

338

TABLE 1-1
SATURATION TEMPERATURES

Temp. F t	Abs. Pressure
	Lb. Sq. In. p
300	67.013
320	89.66
340	118.01
350	134.63
360	153.04
380	195.77
400	247.31
420	308.83
440	381.59
460	466.9
480	566.1
500	680.8
520	812.4
540	962.5
560	1133.1
580	1325.8
600	1542.9
620	1786.6
640	2059.7
660	2365.4
680	2708.1
700	3093.7
705.4	3206.2

CG-063

therefore, any heat not used by the heat consumers in the distribution system is returned to the plant and reheated to normal operating temperatures. The entire HTW distribution system is filled with constantly circulating HTW. When heat is needed, it is readily available in the system. The distribution piping acts as a storage shed for the HTW and is normally referred to as the *flywheel effect* of HTW.

Components. The components of an HTW system are designed to provide safe and efficient operation. The basic components of an HTW system are: boilers or generators, expansion drum(s), system circulating pump(s), distribution piping, and heat consuming equipment.

Exercises (600):

1. Cite the operating principles of HTW systems.
2. How much pressure is necessary to keep water in a liquid state at 350° F.?
3. What is the temperature range of HTW?
4. How does HTW compare to steam as a heating medium?
5. Identify the components of an HTW system.

1-2. Generator Designs

The designs of HTW generators range from converted steam boilers to specially designed HTW units. In between these two extremes are the cascade or direct contact heaters.

601. Describe various design characteristics of a converted steam boiler and the cascade system, and identify the components of a cascade heater.

Converted Steam Boilers. This is a means by which water tube steam boilers are modified and used to generate HTW. (Fire tube boilers should not be considered for conversion to HTW generators.) Figure 1-1 illustrates one method of converting a steam boiler and using the old steam drum as an expansion tank. This modified design requires extensive reworking of the boiler downcomer tubes and piping of the return water to the bottom drum. Figure 1-2 illustrates another method of converting a steam boiler, with little modification to the boiler. The primary

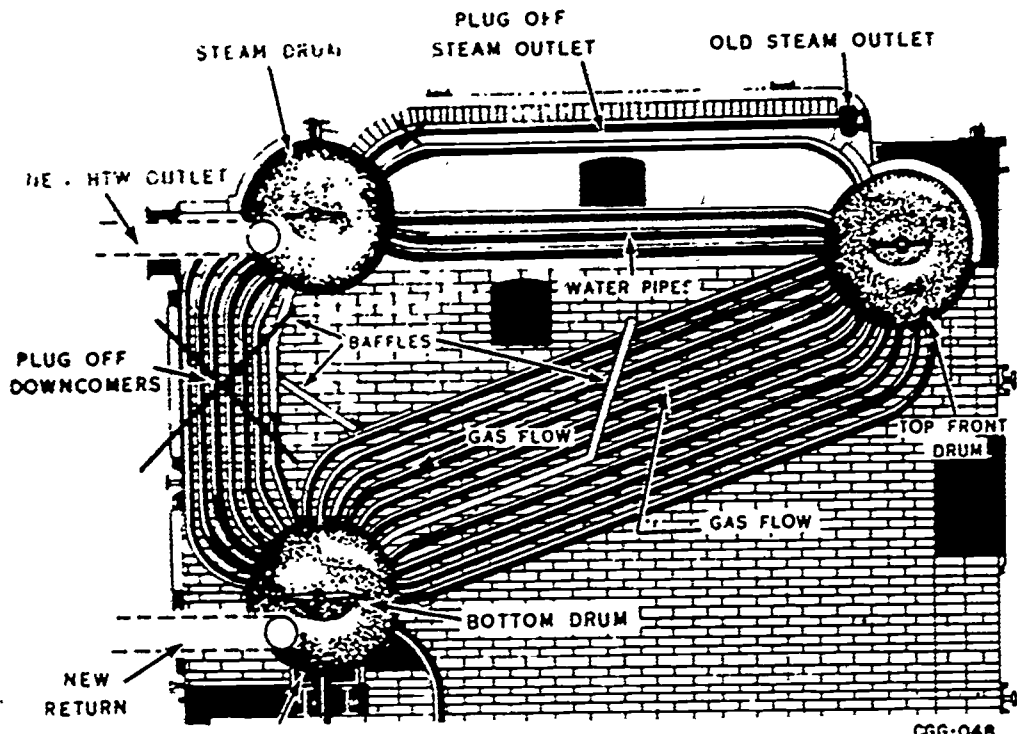


Figure 1-1. Converted steam boiler.

modification in this system is the baffle arrangement in the expansion drum, which allows the system water to enter the drum but prevents velocity of the water in the system from interfering with the natural circulation in the boiler. There are no converted steam boilers in use in the Air Force.

Cascade Systems. The cascade or direct contact heater is a successful means of generating HTW (fig. 1-3). It is currently in use in several major Air Force installations. The return water from the HTW system enters the cascade through perforated spray pipes which spray the water over a stack of trays (fig. 1-4). The steam (produced by an independently fired steam boiler) enters the cascade through a perforated plate and mixes completely with the water. The heated water and the condensed steam drop to the bottom of the cascade where the system pump circulates the water throughout the distribution system.

Exercises (601):

1. What type of steam boilers are converted for HTW use?

2. Describe the two modifications commonly used to convert steam boilers to HTW generators.
3. What is the purpose of the specially designed baffles in the expansion drum?
4. What is another name for a cascade heater?
5. Identify the components of a cascade heater.

602. Name the three basic designs of forced flow HTW generators, and cite the action that should be taken if a low water condition exists in an HTW generator.

Forced flow HTW generators are specially designed for HTW use.

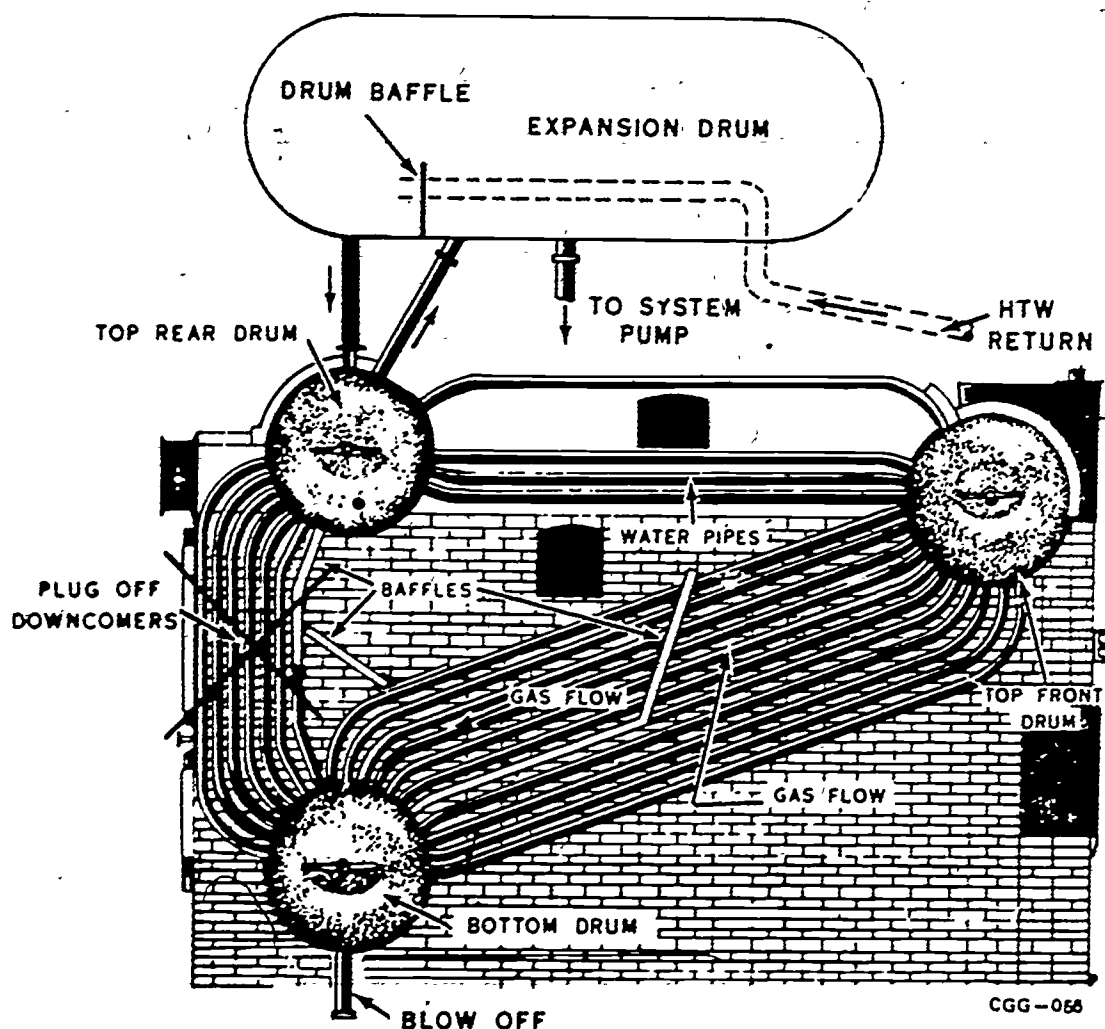


Figure 1-2. Converted steam boiler, separate expansion drum.

Continuous Upward Flow Generators. This generator has its inlet located on the bottom rear of the unit (fig. 1-5). The water enters the tube circuits and progresses in a continuous upward movement to the generator outlet.

Counterflow Economizer Generators. These units receive the return HTW through the top rear of the generator and circulate it down through an economizer. The economizer absorbs heat from the hot flue gases which would otherwise be wasted to the atmosphere. Figure 1-6 illustrates the flow path of this type of generator.

Upward Flow Economizer Generators. This generator is similar to the counterflow economizers except the return water enters at the bottom rear of the unit and passes upward through the economizer. Figure 1-7 shows the flow path of this generator. Flow is from A through F, in alphabetical order.

Flow Theory. Regardless of the flow design of an HTW generator, a constant flow of water through the tube circuits is necessary. All specially designed generators have smaller diameter and more closely spaced tube circuits than do steam boilers. A tremendous amount of heat is applied to these tubes from the generator fires, so the least interruption of circulation can cause tube failure. A low water flow condition in an HTW generator is extremely critical, and in all cases, the fires should be extinguished immediately.

Exercises (602):

1. Name the three basic designs of forced flow HTW generators.
2. What action should be taken in the event of low water flow through an HTW generator?

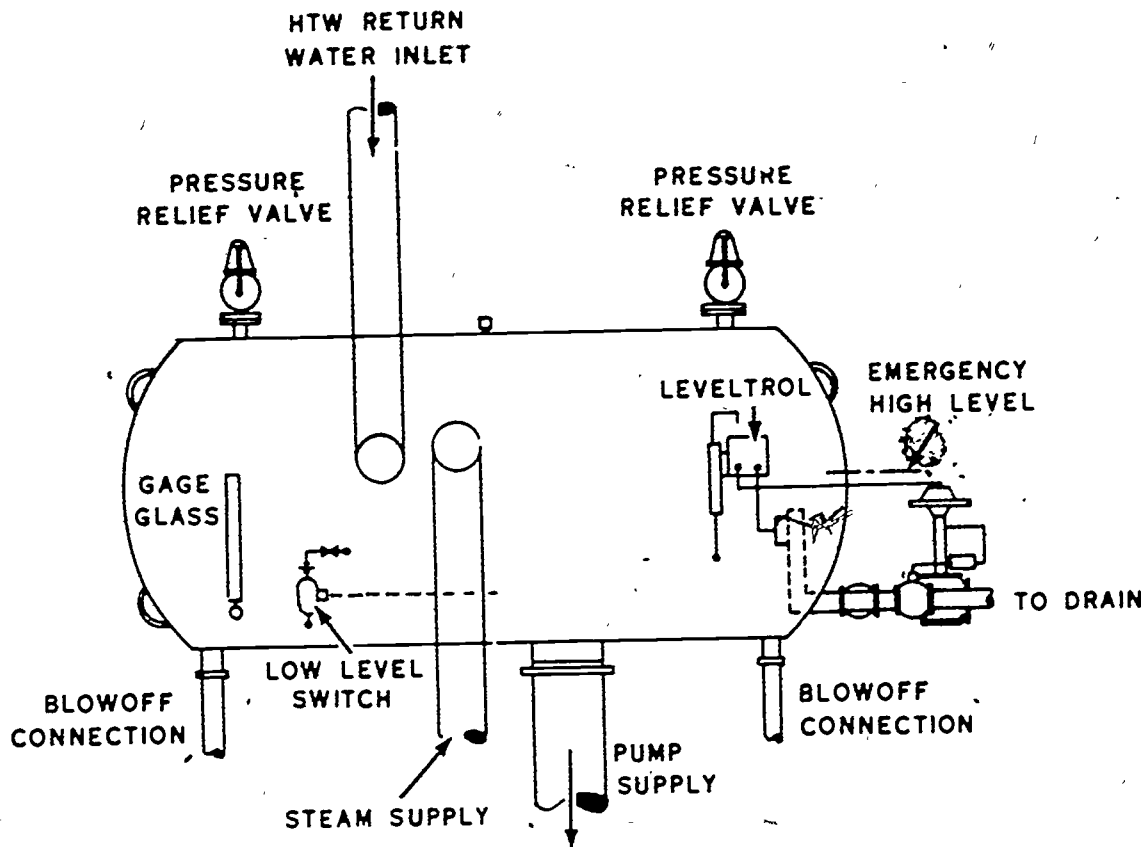


Figure 1-3. Direct contact heater.

603. Differentiate between the forced flow and natural circulation generator design.

The only true natural circulation generator for HTW is the converted steam boiler discussed under Learning Objective 601. The forced flow generators were discussed in Learning Objective 602. The primary difference between these two systems is that all forced flow generators rely on a pump to force the water through the generator, while the natural circulation generator relies on the difference in the weight of hot and relatively cooler water.

Exercise (603):

1. Differentiate between the forced flow and natural circulation generator design.

1-3. Auxiliary Equipment

Auxiliary equipment is equipment that combines with the HTW generator to make up

the HTW central heating plant. This equipment includes expansion drum(s), pumping system(s), bypass valve(s), soot blowers, mixing connection(s), safety controls, and temperature recording equipment. Each of these pieces of equipment will be covered in detail in the following learning objectives.

604. Specify each of the pressurization methods used in an HTW system and describe their characteristics.

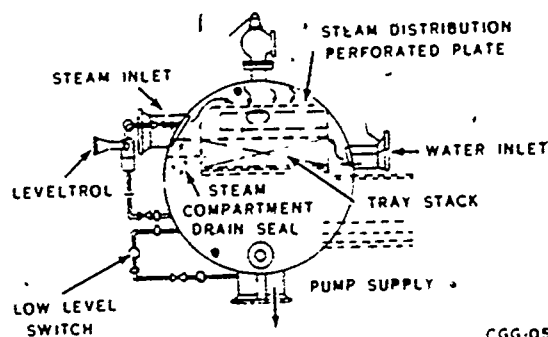


Figure 1-4. End cutaway of a direct contact heater.

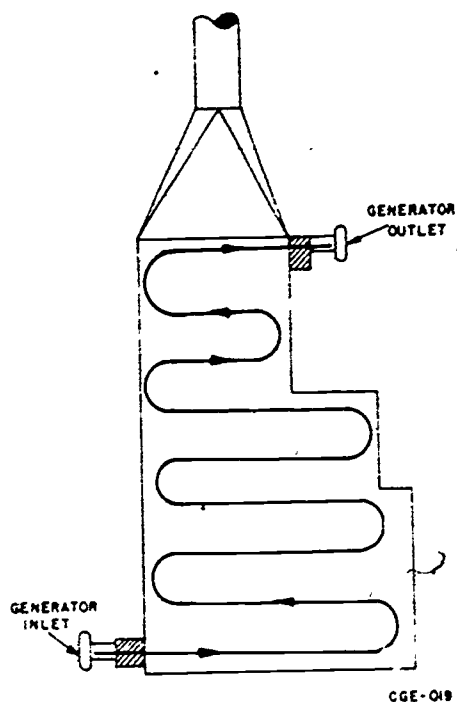


Figure 1-5. Continuous upward flow circuit.

There are two basic methods of pressurizing an HTW system: (1) the saturated steam cushion method and (2) inert gas pressurization. Pressurization is necessary to keep the HTW in a liquid state. This is accomplished through use of an expansion drum. The expansion drums used in low and medium temperature water are similar to those used in HTW, in as much as they both allow for expansion. However, after this

point, they are quite different, both in size and function.

Saturated Steam Cushion Pressurization. In this system, the expansion drum is normally installed in a horizontal position (fig. 1-8). Two, or at the most, three expansion drums may be installed in series. The drum is filled approximately half full of water and the generator is fired to heat up the water. A vent valve is opened on the top of the drum and a portion of the hot water flashes to steam. Once a steam cushion is established, the vent valve is shut off. The HTW flowing from the generator into the expansion drum expands and pushes against the steam cushion. The steam cushion in turn pushes back against the water, pressurizing the system. The pressure in the expansion drum is equal to the saturation temperature of the water. Referring back to table 1-1, if the generator is operating at 380° F., then the expansion drum pressure will be 195.77 psia. This pressure/temperature relationship will always remain constant. If the generator output temperature drops to 370° F., then the water level in the expansion drum will decrease and the resultant steam pressure will be 173.37 psia. Air is not used as a means of pressurization, because oxygen is corrosive to drum surfaces. Referring again to figure 1-8, note that the HTW leaves the generator and flows through the expansion drum; therefore, the drum is always hot and should be insulated accordingly.

Inert Gas Pressurization. In this method of pressurization, an inert gas (normally

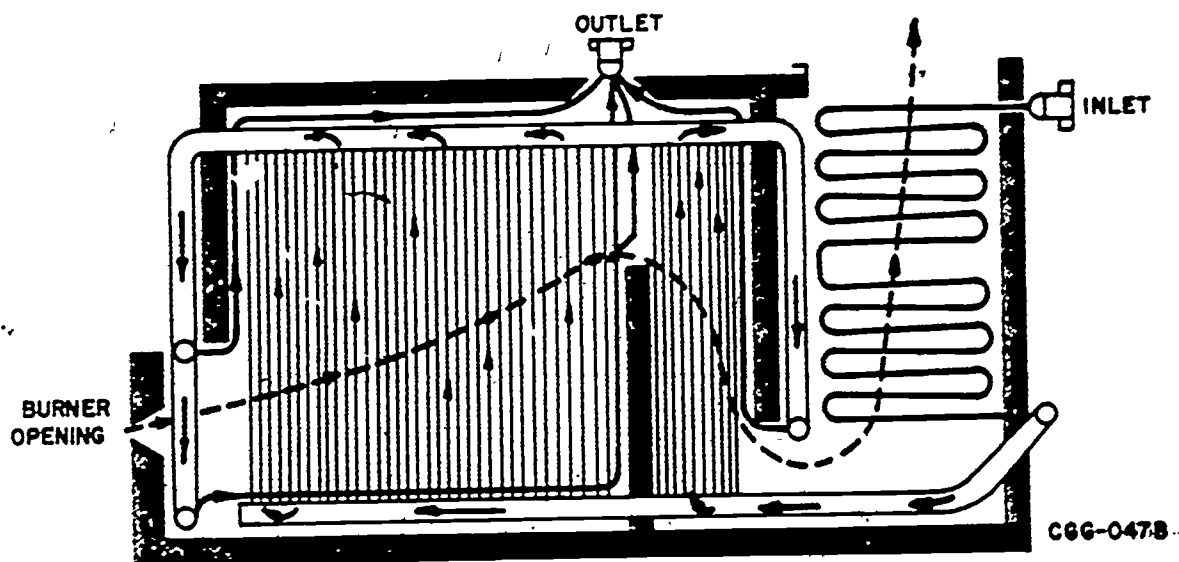


Figure 1-6. Counterflow economizer HTW generator.

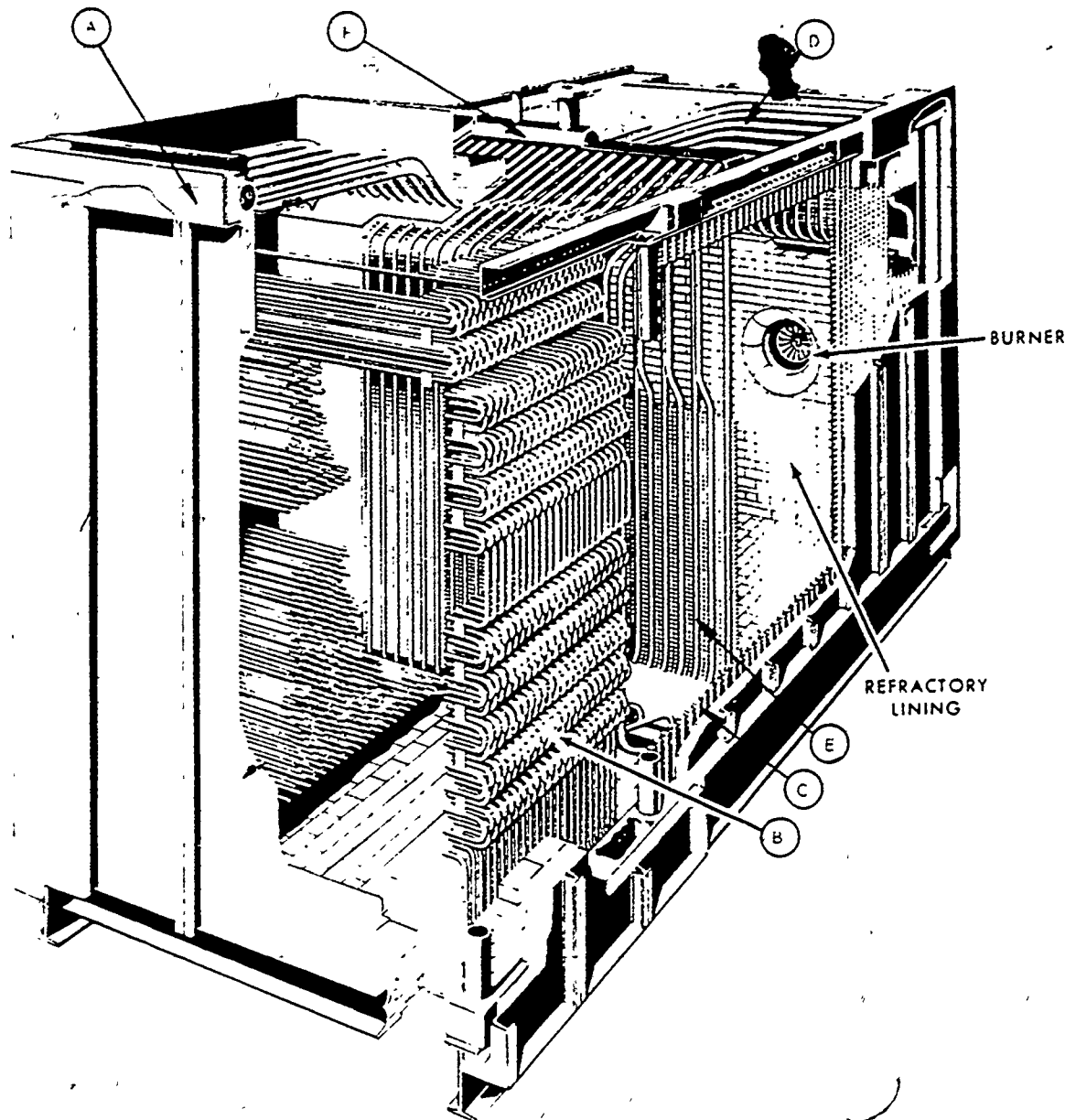
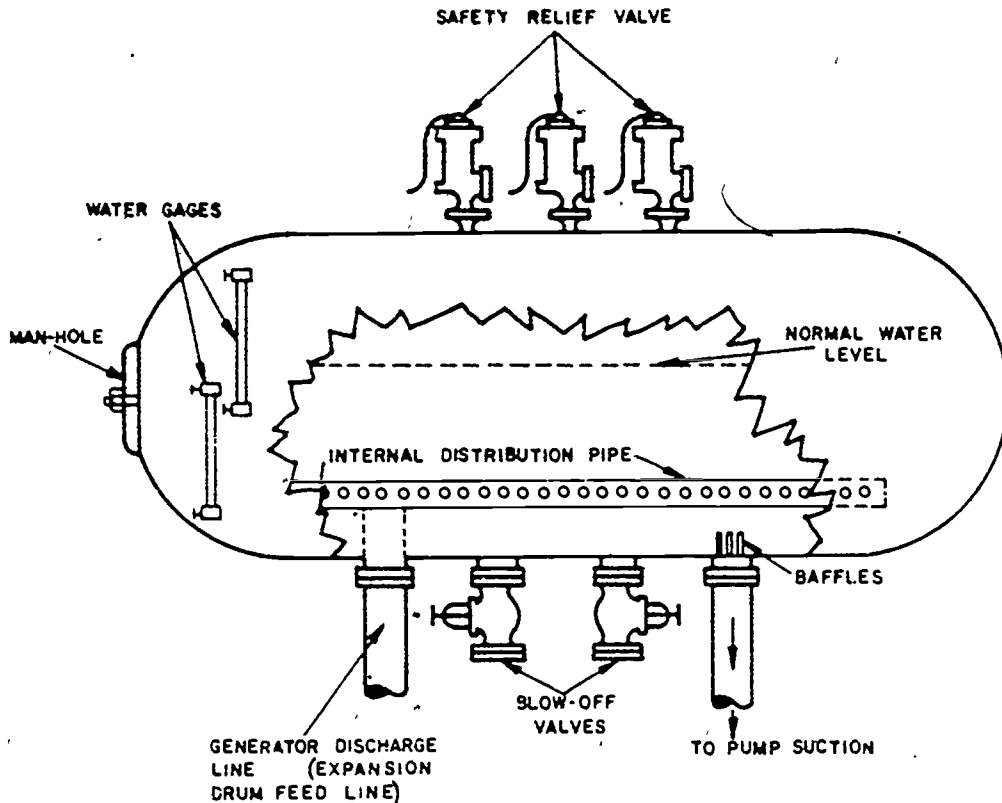


Figure 1-7. Upward flow economizer.

nitrogen) is used. Figure 1-9 illustrates an inert gas cushion expansion drum. Note that there is no circulation of water through this drum. It is connected to the return HTW distribution line by a balancing line. Any expansion or contraction of the water level in the expansion drum will accordingly place more or less pressure on the gas cushion. There are no safety relief valves on the expansion drum. Since there is no flow of HTW through the expansion drum, it remains relatively cool. Figure 1-10 illustrates a fixed nitrogen gas cushion, which is installed on the generator outlet line (in the same manner as

the steam cushion expansion drum). These fixed gas cushions are placed in operation by filling the drum approximately half full of water and then applying a nitrogen gas charge of approximately 25 percent above the saturation pressure of the normal operating temperature. Then the generator is fired and the system water expands as it is heated. As the expanding system water pushes against the gas cushion, the pressure is increased, and some of the inert gas will have to be vented to the atmosphere. This procedure is repeated until the generator and the system are at normal operating temperatures. The inert gas

344



CGE-026

Figure 1-8. Saturated steam cushion expansion drum.

cushion will remain at a constant pressure, as long as the water temperature remains constant. If there is a wide fluctuation in the water temperature, then nitrogen gas will have to be added or bled off. Most nitrogen gas pressurized systems are more expensive to install and operate than are saturated steam cushion systems. The majority of the HTW systems in the Air Force use saturated steam cushions.

Exercises (604):

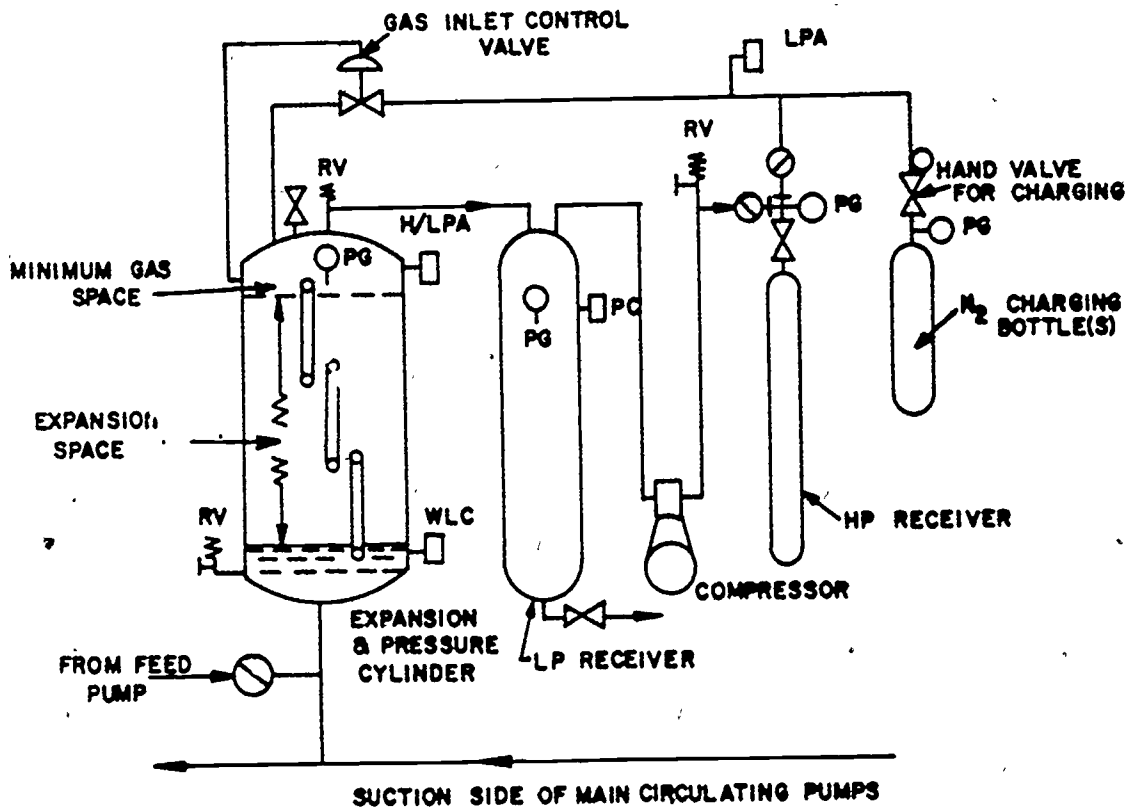
1. Specify each of the pressurization methods.
2. Describe the characteristics of the two pressurization methods.

605. Identify the proper control of a steam pressurized system, and explain the correct operation of a gas pressurized system.

Saturated Steam Cushion. The pressure of a saturated steam cushion is controlled by the firing rate of the generator. If the firing rate increases, the hotter water expands and pushes against the steam cushion, creating more pressure. If the firing rate declines, then the temperature of the water entering the drum is lower, and the water contracts. This contraction decreases the amount of force pushing against the steam cushion which causes a reduction in pressure.

Inert Gas Cushion. The operation of the fixed gas cushion was explained in Learning Objective 604 and it is quite similar to the saturated steam cushion. The variable gas cushion system (fig. 1-9) uses a preset pressure control valve and a relief valve to maintain a constant pressure on the expansion drum. If the temperature of the system water increases, and the water expands, the relief valve on the top of the expansion drum opens and allows the excess gas to escape to a low pressure receiver. From the low pressure receiver, a compressor picks up the gas and pumps it into a high pressure receiver. If the water temperature drops and the water contracts, the inlet control valve will open

345



RV = SAFETY VALVE
 PG = PRESSURE GAUGE
 PC = PRESSURE CONTROLLER
 LPA = LOW-PRESSURE ALARM

H/LPA = HIGH AND LOW PRESSURE ALARM
 WLC = WATER LEVEL CONTROL

CGE-022

Figure 1-9. Gas pressurization.

and allows gas to pass from the high pressure receiver into the expansion drum. Nitrogen bottles are available for initial charging of the system, or making up any losses.

Exercises (605):

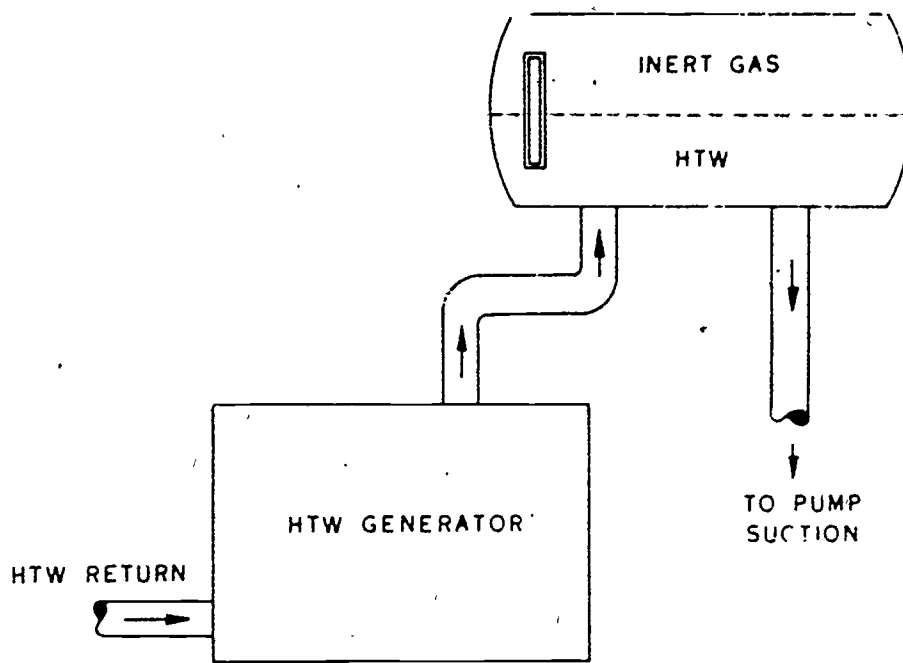
1. Identify the proper control of a steam pressurized system.
2. Identify the correct operation of a gas pressurized system.

606. Describe the operational fundamentals of the pumping system of HTW.

Pumping systems are used in HTW systems to circulate the system water. These pumps are single-stage, centrifugal force units and

may be either constant or variable speed. Constant speed pumps operate at one constant speed at all times. Variable speed pumps can be adjusted to a wide range of speeds by adjusting a transmission, coupling, or varying the amperage applied to the drive motor. These pumps produce a relatively flat head in the range of 10 to 15 percent above the expansion drum pressure. HTW circulating pumps use oil (no grease) for lubrication; and the bearings, the oil, and the packing are cooled by cold water being piped to these areas. Cold water is necessary due to the operating temperatures of HTW.

Combined Pumping System. This system uses one pump to circulate the HTW throughout the entire system and through the generators (fig. 1-11). The pump draws its suction from the expansion drum, where the drum uses a saturated steam cushion or an inert gas cushion installed above the generator outlet. When an inert gas cushion is installed on the HTW return line, then the combined pumping system draws its suction from the



CGE-028

Figure 1-10. Fixed gas cushion.

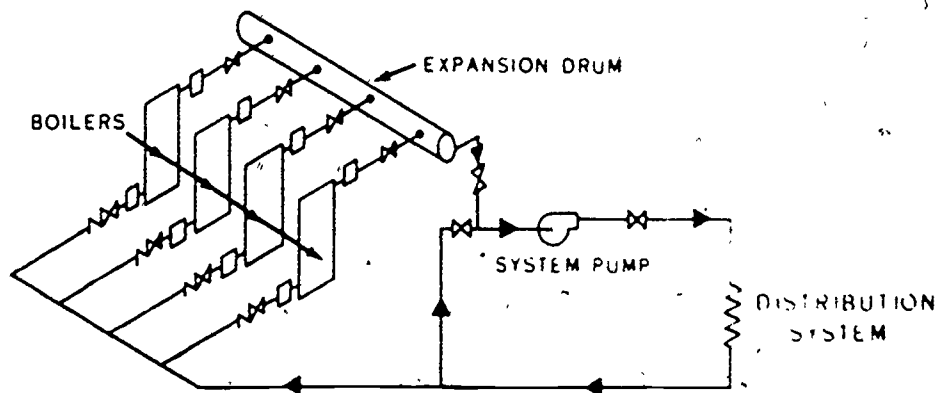
generator(s) discharge header (fig. 1-12). This system is called a combined pumping system because it satisfies the circulation needs of both the system and the generator(s). The combined pumping system is normally used on large systems.

Separate Pumping System. This system uses one pump for circulating water through the distribution system and another pump to circulate water through the generator (fig. 1-13). The distribution system of the combined pumping system is normally divided into zones, with a pump installed for each zone. Each generator is equipped with its

own circulating pump installed on the generator inlet.

Exercises (606):

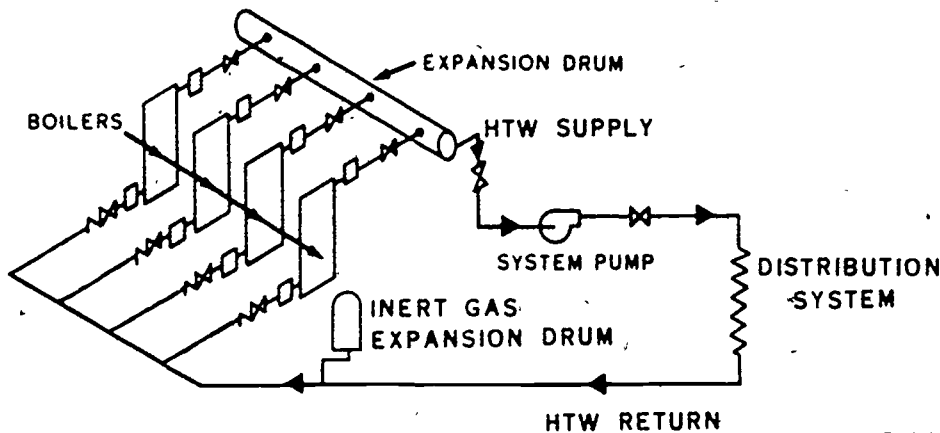
1. Describe the operational fundamentals of the pumping systems of HTW.
2. How many pumps are used in a combined pumping system?



CGE 030

Figure 1-11. Combined pumping system.

347



CGE-031

Figure 1-12. Inert gas, combined pumping.

607. Cite the use of a bypass valve.

The bypass valve is an automatic valve which bypasses HTW from the discharge side of the system pump and feeds it into the generator. This valve automatically opens whenever the generator is receiving insufficient water. It is always installed on combined pumping systems (fig. 1-14), and it is normally installed on separate pumping systems.

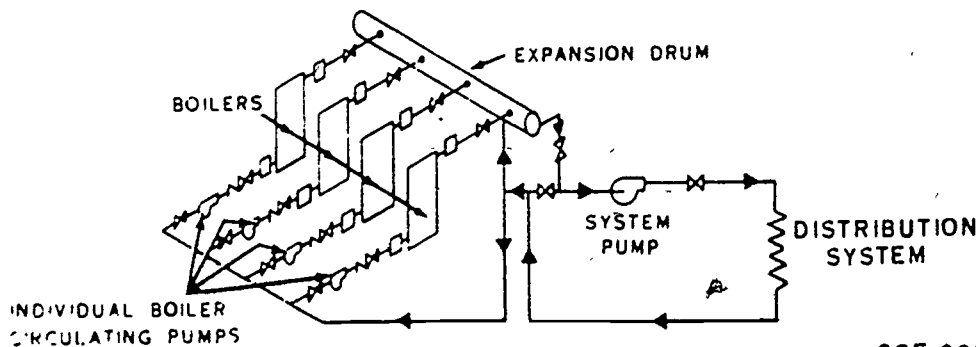
Exercise (607):

1. Cite the use of the bypass valve.

608. Explain the operation of soot blowers.

Soot blowers are installed in the connection tube tank circuit, of HTW

generators, to reduce soot accumulations and to increase operating efficiency. Most of the soot blowers used in HTW are the air-puff variety, which uses compressed air at approximately 100 psi. STEAM FROM THE EXPANSION DRUM WILL NOT BE USED. The soot blower elements are round steel tubes, with holes or orifices on one side. These elements rotate, blowing air across the connection tubes. A cam-valve arrangement sends a blast of air into the element. When the air pressure drops to a preset value, the valve shuts off the air to the element, thus the term "air-pull." The cam rotates the element. Only one element is operated at a time, starting with the element nearest the bottom of the generator (fig. 1-15). Soot is blown only when the generator is in operation. Soot should not be blown when the generator is firing at reduced loads, as this could extinguish the fires. An abnormal rise in the flue gas temperature is a good indication that soot is accumulating on the connection tubes and preventing them from absorbing the heat.



CGE-033

Figure 1-13. Multiple boiler HTW separate pumping system.

348
J

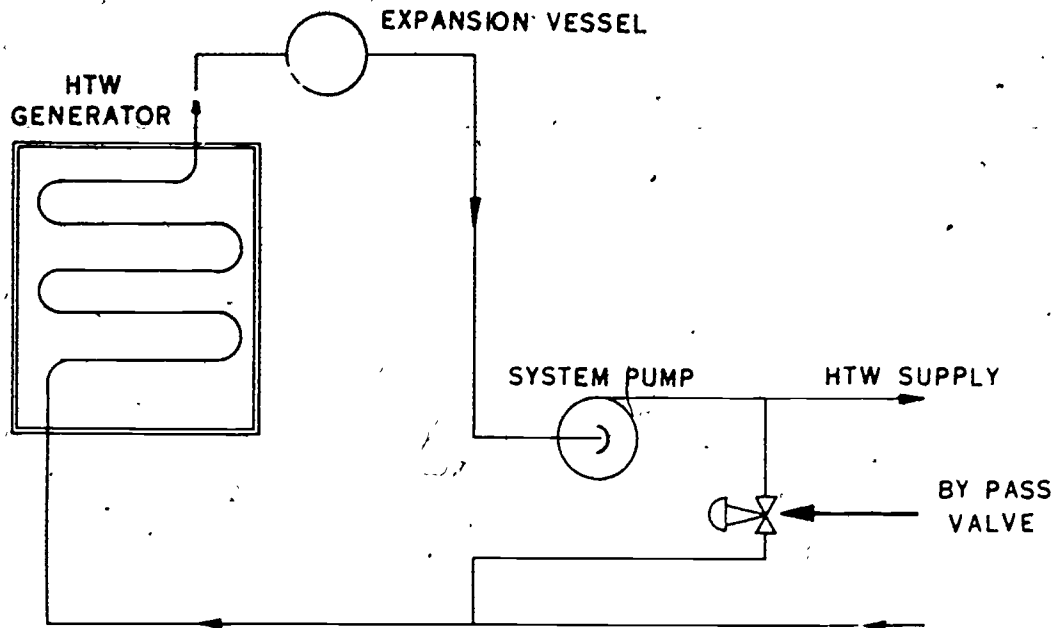


Figure 1-14. Bypass valve.

Exercises (608):

1. Explain the operation of soot blowers.
2. What could happen if soot is blown during reduced loads?
3. What is a good indication that soot should be blown?

supply), the supply water temperature is reduced to a point below the saturation pressure and flashing is prevented. The amount of return water blended is controlled by a manual globe valve (fig. 1-17). The mixing connection may also be used to balance the various zone supply temperatures. Assume zones 1, 3, and 4 are supplying water at a temperature of 370° F. and zone 2 is supplying water at 380° F. By feeding more return water into the zone 2 pump mixing connection, the discharge temperature will be lowered.

Exercises (609):

609. Explain the operation of a mixing connection and name two of its functions.

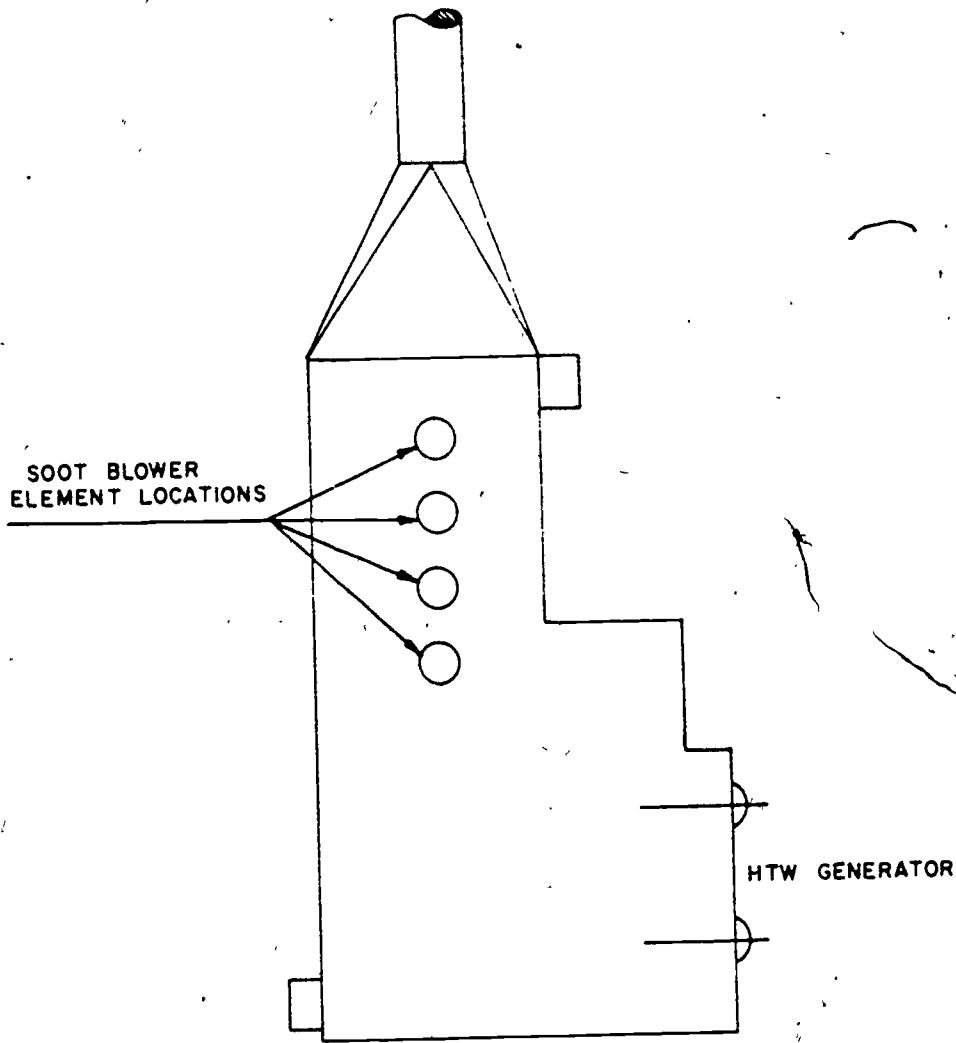
1. Explain the operation of a mixing connection.
2. Name the two functions of the mixing connection.

Mixing Connection Operation. The mixing connection is a pipe within a pipe (fig. 1-16) which blends cooler return HTW with supply HTW to prevent flashing in the circulating pump. This connection is installed on the suction side of the circulating pump. In operation, a centrifugal force pump pulls a partial vacuum in the eye of the impellor. This is sufficient to reduce the pressure of the supply HTW and allows it to flash to steam. By blending cooler return water (approximately 100° F. cooler than the

610. Identify and describe the operation of safety controls for HTW.

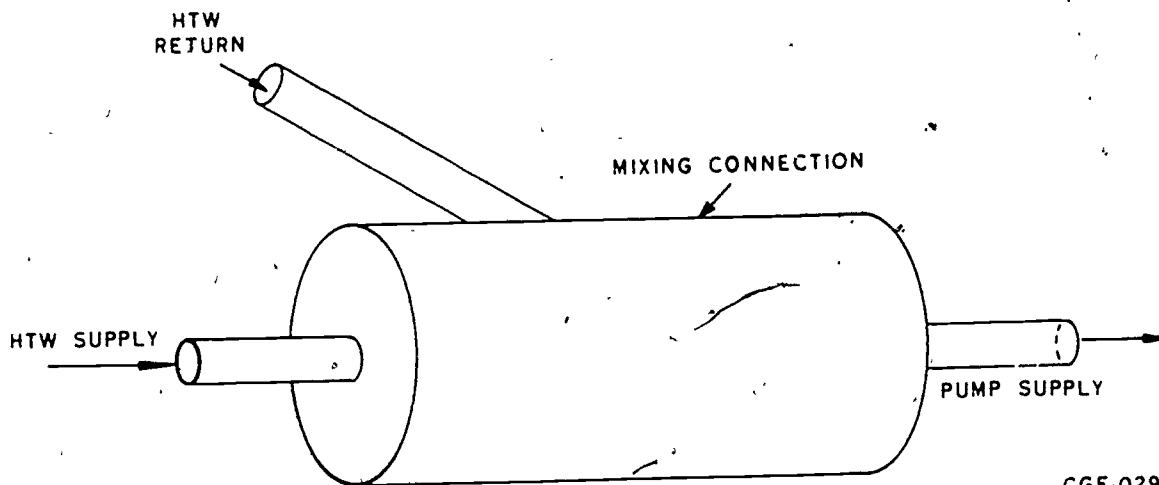
Safety controls are system and plant monitors which permit safer, more economical, and more efficient automatic

349



CGE-018

Figure 1-15. Soot blower locations.



CGE-029

Figure 1-16. Mixing connection.

350

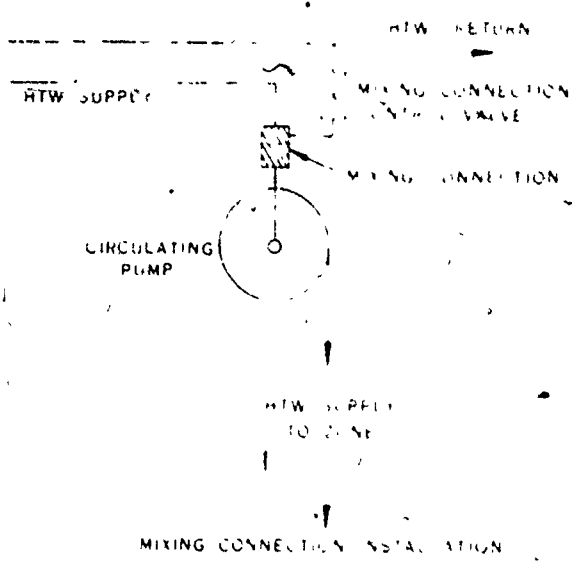


Figure 1-17. Mixing connection installation.

operation. In the event of a malfunction, these controls automatically cut off the fires and sound an alarm. Many systems also have an annunciator signal board which flashes on a red light indicating the problem.

Differential Pressure Control. This control senses the pressure of the water entering and exiting the generator. The outlet pressure should equal the inlet pressure minus the resistance in the generator tube circuits. The two pressures *prove* that there is water flow through the tubes. The control is set at the minimum flow of water at which the generator can continue to operate (minimum flow requirements are determined by manufacturer's recommendations). The differential pressure control sends a signal to the bypass valve (Learning Objective 607) when the flow begins to fall and causes the valve to open. Should the flow continue to drop, the differential pressure control will secure the fires in the generator. Some of the more common causes of low flow are: inoperative circulating pump; generator inlet valve erroneously shut off; and a ruptured or broken pipe in the distribution system. The differential pressure control will also secure the fires in the generator in the event the pressure between the generator inlet and outlet exceeds a preset valve. The causes of high pressure are normally attributed to someone shutting off the wrong valve (generator discharge valve), however, it could also indicate blockage in the generator tube circuits.

Minimum Flow Control. Either a minimum

flow control or a differential pressure control must be installed on each HTW generator (some systems use both). The minimum flow control is normally integrated with an indicating and recording flowmeter, which is actuated by an orifice installed in the generator water inlet line. The orifice monitors the flow of water entering the generator. Any time the flow falls below the setting of the flowmeter, the generator fires are automatically secured. The minimum flow control also operates the bypass valve in the same manner as the differential pressure control.

Thermocouple Control. Each HTW generator should be equipped with a thermocouple control. This control consists of a temperature sensing instrument and three thermocouples attached to the discharge tubes of each of these critical generator tubes recommended by the manufacturers. (The criticality of a generator tube is determined by how much heat is being applied to it by the generator fires.) A thermocouple is a thermoelectric pyrometer (a device to measure temperatures beyond the range of a mercury-in-glass thermometer). The more heat applied to a thermocouple, the more electricity will be generated. The wires from the thermocouples are attached to a millivoltmeter calibrated to read in degrees Fahrenheit or Celsius. When the boiler temperature rises above a preset safe operating level, the excessive temperature causes any of the thermocouples to activate the controls and secure the generator fires.

Expansion Drum Water Level Controls. HTW systems have high and low water level controls to stop the firing equipment when the water in the expansion drum reaches abnormal predetermined levels.

Flame Failure Control. This control is actuated by a flame sensing device which sees the fire. In the event of flame failure, it will secure the firing equipment.

Air Flow Switch. This control will prevent the generator from firing an initial light-off, or secure the fires when the unit is in operation if there is insufficient draft to support combustion. On package HTW generators, the air flow switch is integrated with the programming control and insures proper prefiring and postfiring purge periods.

High-Limit Pressure Control. This control secures the generator fires when a preset high pressure is reached. It is normally installed in the top of the generator and in the expansion drum.

350

Exercises (610):

1. Identify the HTW controls from the following list and describe the operation of each.

- a. Differential pressure control.
- b. Minimum flow control.
- c. Thermocouple control.
- d. Expansion drum water level control.
- e. Vaporstat control.
- f. Flame failure control.
- g. Airflow switch.
- h. High-limit pressure control.
- i. Fan control.
- j. Pilotstat control.
- k. Pressuretrol.

611. Name the type of temperature recording equipment used in HTW systems, and specify the functions of the Btu meter.

Temperature Recorders. Temperature recorders normally used in HTW are flue gas, supply water temperature, and return water temperature.

Flue gas temperature recorders. These recorders consist of a remote bulb, capillary

tubing, a helical coil, and a pen and proper linkage attached to the free end of the helical coil. The pen records on a chart which is mounted on a circular rotating assembly. The rotating assembly is operated by clockwork or a synchronous electric motor. The remote bulb is inserted into the stack after the last pass. The bulb and the capillary tube are filled with a gas which expands when heated. The capillary tube is attached to the bulb and one end of the helical coil. The helical coil moves proportionately to the expansion of the gas and moves the pen on the recording chart accordingly. Most charts turn a complete circle (360°) in 24 hours. Therefore, these charts are normally changed immediately after the midnight (2400 hours) reading.

Btu meters. Btu meters have temperature recorders integrated in them. The Btu meter senses and records the HTW supply and return temperatures. The meter also integrates these figures and the pounds of water circulated and records the Btus. Btus are determined by the following formula:

$$\text{Pounds of water circulated} \times (\text{supply water temperature} - \text{return water temperature}) = \text{Btus per hour consumed by the system.}$$

In some cases, the Btus can be read directly from the meter. In other cases, it is necessary to multiply the meter reading by an integrator factor. This integrator factor is a number determined by the meter manufacturer and is stamped on the face of the meter. The factor numbers are preceded by an X signifying this factor times the meter reading. Btu meter sensors are installed in the inlet and outlet of each HTW generator, and they transmit the data to the Btu meters installed on each generator control panel. There may also be Btu meters installed on each zone in the separate pumping system.

Exercises (611):

- 1. Name the types of temperature recording equipment used in HTW systems.
- 2. Specify the functions of the Btu meter, and cite the formula for determining the Btus per hour consumed by a system.

1-4. Operation and Maintenance

Proper operation and maintenance add

years to the life of an HTW system and reduce operating cost.

Operation and maintenance deal with: light-off procedures and operational check of an HTW generator; bleeding air from the system; methods of distributing HTW; the classes of conduits and inspection procedures for conduits; the types of expansion joints used and their maintenance requirements; and identification of the types of valves used and their maintenance requirements.

612. List the operational inspections and procedures for lighting off a generator.

In normal operating practices, each HTW plant or generator has its own particular light-off procedures. The following is a hypothetical example of starting a typical plant and placing additional generators in service.

Preliminary Inspection. Prior to starting an HTW generator, inspect the installation carefully and make sure that the following requirements are satisfied: all installation, repair, and cleanup work is completed; all air and gas passages are tight and free from obstructions; all dampers are in good operating condition; all piping checked for leaks and insulated as necessary; all piping checked for proper installation; all auxiliary requirement required to operate the generator is properly installed and ready for operation; all manholes, nanuholes, access and observation doors are closed; CAUTION: Check and make certain no one is inside the generator prior to closing manholes and access doors; a hydrostatic test of $1\frac{1}{2}$ times the pressure setting of the safety valves is applied to the generator; nitrogen gas and equipment are available for gas pressurized systems.

Starting the Combined Pumping System. When the system is cold and not under pressure, proceed as follows: See that the proper water level is carried in the expansion drum; open inlet and outlet valves of the generator, expansion drum, and system; open the inlet valve to the circulating pump, start the pump, and then open the discharge valve; check the waterflow through the unit and vent air from headers and high points in the system; make a final check of limit and safety controls.

Lighting Off the HTW Generator. After the preliminary inspection and starting up procedures are completed, the generator is ready to be fired. First, close all induced and forced draft dampers, then start the induced and forced draft fans. (This procedure prevents an excessive starting load on the fan motors.) After induced and forced draft fans

353

are operating, purge the setting of all combustible gases by circulating air for at least 5 minutes at the rate of about one-fourth of the requirements for maximum capacity of the unit. (The same purge period is observed when relighting a hot generator. If a hot generator is purged above one-fourth of the generator requirements, then stresses may be put on the generator tube circuits and refractory, due to rapid cooling.) Now, light off the generator and keep a firing rate sufficient to raise the temperature of the water to 212° F. in not less than 90 minutes. (This time period is important. If a generator is heated too rapidly, thermal expansion could cause extensive damage to the tube circuits and refractory.) The temperature is gradually increased at a rate of not more than 100° F. per hour. (The combined pumping system is started with the generator and the distribution system in operation. As such, a temperature increase in excess of 100° F. is difficult to obtain.) Throughout the lighting off period, check the generator and associated piping and make certain that thermal expansion has not caused any stresses or strains. If any are found, secure generator fires immediately and correct the problem. Observe the fires continually to ascertain complete combustion. Incomplete combustion may occur with a cold generator, and this causes an accumulation of unburned fuel or explosive gases in the generator. This could lead to an explosion or uncontrollable combustion once the generator warms up. When bringing the generator up to normal operating temperatures, control the firing rate manually until the desired temperature is reached, then switch to automatic.

Exercises (612):

1. List the operational checkups made during the preliminary inspection.
2. List the items to be inspected when starting the combined pumping system.
3. List the procedures for lighting off the HTW generator.

MONTHLY HIGH TEMPERATURE WATER PLANT OPERATING LOG										7. COMMAND		8. BASE AND LOCATION		9. BUILDING NO. AND NAME				10. MONTH AND YEAR		
DATE	EXPANSION TANK		BOILER OUTPUT (Million BTU)				PEAK DEMAND FACTOR (%)	FLUE GAS				FUEL USED				TOTAL INPUT (Million BTU)	PLANT COEFF. (%)	PLANT OVERALL EFF. (%)	TOTAL MANHOURLS OPERATION	
	PRESS. (PSIG)	TEMP. (°F)	BOILER NO.					CO ₂ (WT %)		TEMP. (°F)		COAL		OIL						TOTAL
			1	2	3	4		1	2	3	4	1	2	3	4					
1																				
2																				
3																				
4																				
5																				
6																				
7																				
8																				
9																				
10																				
11																				
12																				
13																				
14																				
15																				
16																				
17																				
18																				
19																				
20																				
21																				
22																				
23																				
24																				
25																				
26																				
27																				
28																				
29																				
30																				
TOTAL																				

11. MONTHLY BOILER OUTPUT (Million BTU)		12. MONTHLY FUEL USED (Million BTU)		13. MONTHLY PLANT OVERALL EFF. (%)		14. MONTHLY PLANT COEFF. (%)	
1	2	3	4	5	6	7	8

18

Figure 1-19. AF Form 1166.

DE-1143A

355

INSTRUCTIONS

All installations having a high temperature water heating plant use AF Form 1163. Same as the instrumentation from which data for this log is obtained as described in AFM 48 15 and AFM 48 12. The chief operating engineer prepares AF Form 1163, in duplicate, and posts the form daily at the plant.

Column A. Pressure of the water on the discharge side of each pump.

Column B. Water temperature entering the dist. system.

Column C. Temperature of the return water.

Column D. Total daily amount of water circulated. (Multiply gallon by 8.3 to obtain pounds.)

Column E. Taken from the flow meter. Figures based on total pounds of water distributed to each zone multiplied by the temperature of the return water from each zone subtracted from the supply temperature.

Williams & Morrow's Thousands of pounds (column D) x 0.01 x (temperature column B) minus (temperature column C)

Column F. Total pounds of makeup water for the day. (Multiply gallon by 8.3 to obtain pounds.)

Column G. Divide the pounds of water added (column F) by the total water circulated (column D) and multiply by 100. $\text{Percent} = \frac{\text{Makeup water (column F)}}{\text{Total water circulated (column D)}} \times 100$

Column H. Self Explanatory.

Column I. The maximum and minimum temperatures during the 24 hour period, divide by 2 and subtract from 65°F. (Do not enter negative results.)

$\text{Degree days} = 65 - \frac{\text{°F Max} - \text{°F Min}}{2}$

Column J. Give amount used by the entire plant, if metered.

Column K. Use if required.

Remarks. Use to indicate any unusual conditions or to explain any irregularities, discrepancies, or omissions. Explain why any of the columns cannot be filled in, i.e., no instrumentation, or instrumentation inoperable, etc.

Signature of the chief operating engineer indicates his approval of the plant operation unless his comments in the remarks column indicate otherwise. At the end of the month he forwards both copies of AF Form 1163 to the base civil engineer for review and approval. After approval the base civil engineer retains the original and forwards the second copy to the major command on or before the 20th of the following month.

HE-1163B

Figure 1-20. HTW distribution log instructions.

362

613. Specify the tasks involved in an operational check of an HTW system and answer key questions about the system.

Log Entries. Operational checks are made on HTW systems on an hourly basis or more frequently if necessary. The information obtained is recorded on a daily log sheet. At the end of the 24-hour day, the log sheet readings are totaled and averaged, and the information is entered on AF Form 1163, Monthly High Temperature Water Distribution System Operating Log; and AF Form 1165, Monthly High Temperature Water Plant Operating Log (figs. 1-18 and 1-19). Figures 1-20 and 1-21 (reverse sides of forms) contain the instructions for completing these monthly logs.

Hourly Readings and Checks. The hourly readings give the operator a clear indication as to how well his plant is operating. While the operator is taking his hourly readings, he has certain operational tasks he must complete.

Cooling water. An operator must check the cooling water of the circulating pumps to determine if the pump is running hot. This is accomplished by the operator putting his hand into the flow of cooling water exiting the pump and sensing the temperature. If it feels overly warm, the valves controlling the quantity of cooling water may be opened wider to permit more to enter the pump.

Electric motors and bearings. The only sure method of checking a motor or bearing for overheating is through the use of a surface-mounted thermometer and the manufacturer's specifications. However, an experienced operator can normally detect a higher-than-normal temperature by placing his hand on the motor or bearing housing. This is accomplished during the hourly readings.

Visual inspection. Operators make a complete visual inspection of the plant. This includes looking for the following: leaks, vibration of equipment (loose or broken anchors or anchor bolts), stress or strain of piping and equipment, fire and safety hazards, condition of the fires in the generator, and smoke exiting the stack.

Noise inspection. An experienced operator becomes attuned to his plant. He becomes accustomed to the normal operating sounds, and he can hear any unusual noise above the din of the plant. He may spend several minutes trying to locate the sound, but he will hear it none the less.

Exercises (613):

1. Specify the tasks involved in an operational check of the HTW system.

2. What is the proper title of the AF Form 1163?

3. What is the proper title of AF Form 1165?

4. How often should an operator inspect his plant?

5. What corrective action should be taken if the cooling water exiting the circulating pump feels warmer than usual?

6. List the checks made during a visual inspection.

614. List the procedures for bleeding an HTW system, and identify the steps for venting air from the plant.

Initial Startup. When an HTW system is initially placed in operation, or restarted after it has been drained, it must be freed of any trapped air. If air becomes trapped in the system, it can stop the flow of water, or in some cases, cause the HTW to flash to steam. When a system has trapped air to the extent that water flow stops, it is referred to as 'air-locked'. The air must be eliminated before flow can be resumed. Trapped air is freed from a filled system by starting at the central heating plant, and opening the vent valves on the supply and return mains until a steady stream of water flows from the valve. Proceed from the plant and bleed the air from the supply and return mains at each manhole or vent point until the end of the mains are reached. Next, open the supply and return HTW valves for each building, and vent the high points of the HTW heat-consuming equipment. Progress through the entire distribution system, one zone at a time, until all air is vented from the system. When placing distribution pumps in operation, vent all air from the pump casing by opening the vent valve until a steady stream of water flows out, then close the vent valve. After the system circulating pumps have been placed in operation, start with the vents on the

10		BOILER DESCRIPTION DATA					
Boiler No.	NAME OF MANUFACTURER	MODEL NO. AND TYPE	DESIGN CAPACITY	FIRING EQUIPMENT (Make, model number & type)	TYPE OF FUEL USED	TYPE OF BOILER	

INSTRUCTIONS

All installations having a high temp. water heating plant. AF Form 1165 where there is more than one plant, each separate plant uses a separate AF Form 1165. Some of the instrumentation from which data for this log is obtained is described in AFM 88-15 and AFM 85-12. The chief operating engineer prepares AF Form 1165 in duplicate and passes the form daily at the last.

Column A The daily average pressure and temperature in the expansion tank.

Column B Total heat output of boiler in million Btu's based on the boiler Btu meter or computed by multiplying the pounds of water through the boiler by the difference between the average inlet and outlet water temperatures to the boiler.

$$\text{Output of Boiler} = \frac{\text{Pounds of water circulated} \times (\text{Outlet water temp.} - \text{Inlet water temp.})}{1,000,000}$$

Column C Take from the daily log and compute by dividing the output for the 1 hour period having the largest output by the sum of the design output rating at the working temperature and pressure, of all the boilers in operation contributing to the total output and multiply by 100. Use this factor as a guide for operation of the optimum number of boilers for maximum efficiency.

$$\text{Percent} = \frac{\text{Highest hourly total output}}{\text{Design output rating of operating boilers (item 10)}} \times 100$$

Column D Take these temperatures at the point immediately after gases have passed the last heating surface in each boiler. (The readings of CO₂ and stack or flue gas temperature must be accurate. Check instruments frequently.)

Column E Check applicable fuel used. Take gas figures from meters, oil figures from meters or tank gaging, and coal from actual weighings or estimated usage.

Column F Multiply the number of fuel units consumed (column E) by the Btu per unit of fuel and divide by one million.

$$\text{Million of Btu's} = \frac{\text{Number of fuel units (column E)} \times \text{Btu per unit fuel}}{1,000,000}$$

Column G For the fuel used (column E) based on CO₂ readings and stack temperature (column D) obtain combustion efficiency for each boiler from applicable efficiency charts in Vol I AFM 85-12. Calculate the average efficiency by adding all boiler efficiencies and dividing by the number of operating boilers. When more than one fuel is used indicate efficiencies for each fuel.

Column H Divide the plant total output (column B) by the plant input (Btu per unit of fuel, column F) and multiply by 100.

$$\text{Percent} = \frac{\text{Total Output of Plant (Column B)}}{\text{Plant Input (Column F)}} \times 100$$

Column I For each boiler indicate the type of firing equipment used.

Column J For each boiler indicate the type of boiler used.

Item 1 Use to indicate any unusual conditions or to explain any large variation, discrepancies, or omissions. Explain why any of the columns cannot be filled in i.e., no instrumentation or instrumentation inoperable, etc.

Item 2 Obtain from fuel contracts or analysis report when currently obtainable.

Item 3 For each boiler multiply fuel used (column E), by the calorific value of fuel used (item 3) and divide by one million. Add values for all boilers to obtain TOTAL.

$$\text{Total fuel used per boiler (column E)} \times \text{Calorific Value of fuel (item 3)} / 1,000,000$$

Item 4 For each boiler divide monthly Btu output (column B) by monthly Btu input (item 7) and multiply by one hundred.

$$\frac{\text{Output for each boiler (column B)}}{\text{Input for each boiler (item 7)}} \times 100$$

Item 5 For the fuel used (column E) based on average monthly CO₂ readings and average monthly stack temperatures (column D) obtain combustion efficiency for each boiler from applicable efficiency charts in Vol I AFM 85-12. When more than one fuel is used indicate efficiency for each fuel.

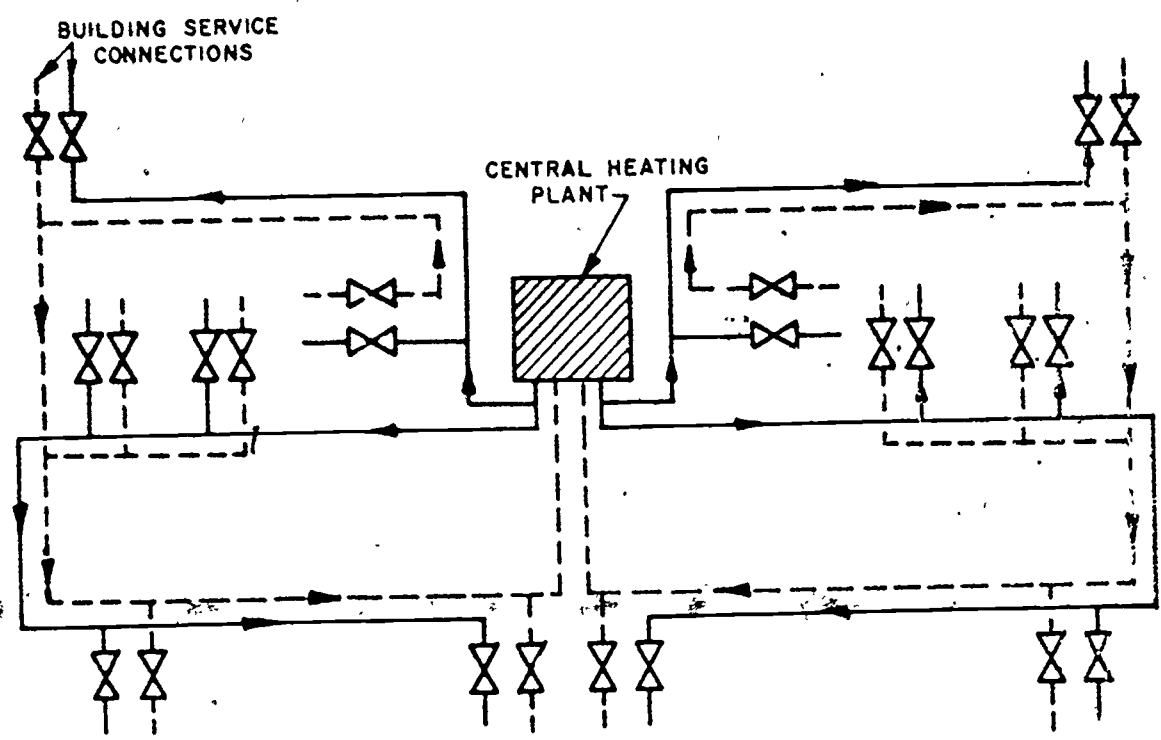
Item 10 (Reverse of form) Unless equipment change is made annotate only in January of each year.

- A Assign a permanent number to each boiler.
- B Self explanatory.
- C For example controlled forced circulation water tube generators, or fire tube boilers.
- D Give the maximum Btu per hour continuous output rating at the operating pressure, entering and leaving water temperatures and pounds per boiler.
- E For example undrilled stack, rotary cup, or high pressure gas burner.
- F For example hand, bin or bunker.
- G For example stationary vibrating traveling chain or dump.

Signature of the chief operating engineer indicates his approval of the plant operation unless his comments in the remarks column indicate otherwise. At the end of the month he forwards both copies of AF Form 1165 to the base civil engineer for review and approval. After approval the base civil engineer returns the original and forwards the second copy to the major command on or before the 20th of the following month.

Figure 1-21. HTW plant-log instructions.





CGE-024

Figure 1-22. Direct-supply radial.

generator header and proceed to vent any air from the equipment and piping throughout the plant.

Exercises (614):

1. List the procedures for bleeding an HTW system.
2. Why should all air be removed from an HTW system?
3. Identify the steps for venting air from the plant.

cost. A reversed-return system is a better designed system, but the cost of the additional piping and fittings needed makes the overall cost of this system prohibitive. The direct-return system is inherently an imbalanced system and requires pipe sizing, pressure regulating valves, or specially designed orifices to balance it. In this system, the first building from the central heating plant to receive the HTW is the first to return the water to the plant. The building farthest away from the plant and the last to receive HTW is also the last to return the water to the plant. This causes the first building to receive the hottest water at the highest velocity, and the last building to get the coolest water at the lowest flow rate, thus it is imbalanced. A balanced system will supply approximately the same temperature water at the same velocity to each and every building on the distribution system.

Exercises (615):

615. Identify the methods of distribution in an HTW system, list the three means of balancing an imbalanced system, and cite the drawback to the reverse-return system.

1. Identify the methods of distribution in an HTW system.
2. List the three means of balancing an imbalanced system.

Piping systems. HTW distribution systems are normally restricted to direct-return piping systems (fig. 1-22). This is primarily due to

3. What is the major drawback to the reversed-return system?

616. Cite the main classes of conduits, and specify the class needed to meet the needs of special conduit system.

Conduit systems are underground, protective, waterproof covers for pipe unsulating material. These systems are classified as types A and B.

Class A Conduits. Class A systems have pressure testable casings and are used when saturated ground may exist above any part of the conduit structure. Class A conduits may be divided into two types and are constructed of metallic casings.

Steel casings. These casings are entirely prefabricated at the factory, including the welding of end collars to the light gage casing. Steel sections lighter than 10 gage are usually hot-dipped, zinc-coated at the factory. Nonzinc-coated steel casings are waterproofed internally. Steel casings that will come in contact with the earth are covered with a waterproofing material. A pipe section is of standard length (normally 21 feet).

Cast iron casings. These casings are also prefabricated at the factory but in shorter lengths than the steel casings. They are normally composed of the pipe, a layer of insulation (of required thickness), a circular airspace, and a cast iron conduit.

Class B Conduits. Class B conduits are made of tile and have premodeled or loose-fill insulation. They are used only in areas where the soil is course grained, as defined by the Unified Soil Classification System. Pipes carried in conduits must be covered with preformed, rigid sectional insulation. There are many different types of class B conduits, and three of the most common will be discussed in the following paragraphs.

Concrete or tile conduits. These conduits may be round, half round, or rectangular, with dimensions varying according to their use. These systems should not be used in areas where flooding may occur. There are two common types, walking tunnel and shallow trench.

a. **Walking Tunnel.** This type of conduit is large enough for personnel to walk through for inspections and repairs. Construction of tunnels are expensive and are used only when required to include other services such as water systems, electricity, telephone lines,

etc. The piping is supported from the walls of the tunnel. The tunnel is made as waterproof as possible by sealing. It has a ditch running lengthwise to the tunnel to drain off any water that may enter. The tunnel floor is sloped to drain the water into the ditch, which in turn is sloped to a drainage point.

b. **Shallow Trench.** This conduit is used when walking tunnels are not required. They are constructed with concrete slab floors and walls, and concrete or tile roofs. The roof is cut in small sections, equipped with lifting eyes. All intersections are waterproofed. The bottom of the trench floor is pitched 2 inches per 100 feet to a manhole to facilitate draining. The pipes are normally supported by rollers mounted on the floor.

Solid pour conduits. In this system, the piping is wrapped with corrugated paper before a mixture of insulation and cement is poured. The conduit is installed on masonry supports which rest on a firm, adequately drained trench bottom. The installation is waterproofed with a heavy asphalt coating before the trench is backfilled.

Asbestos-cement conduits. This conduit is tabular and consists of lengths of asbestos fiber and cement pipe, prefabricated at the factory and molded under hydraulic pressure until smooth and hard. It comes in a standard length of usually 13 feet. Pipe saddles rest on specially designed slip-tape supports in the conduit and are welded to the insulated conduit heating line. The conduit is usually enclosed in concrete for protection.

Exercises (616):

1. List the two classes of conduits.
2. Specify the class of conduit for each of the following systems:
 - a. Steel casing conduit.
 - b. Tile conduit.
 - c. Solid pour conduit.
 - d. Cast iron casing conduit.
 - e. Asbestos-cement conduit.

359

360

TABLE 1-2

EXPANSION OF PIPE PER 100 FEET OF LENGTH
FOR TEMPERATURE SHOWN

Temperature. Degrees F	Material		
	Steel	Wrought Iron	Copper
300	2.376	2.481	3.446
310	2.460	2.570	3.565
320	2.547	2.659	3.685
330	2.632	2.748	3.805
340	2.718	2.838	3.926
350	2.805	2.927	4.050
360	2.892	3.017	4.167
370	2.980	3.108	4.289
380	3.069	3.199	4.411
390	3.156	3.291	4.532
400	3.245	3.383	4.653
410	3.334	3.476	4.777
420	3.423	3.569	4.899
430	3.513	3.662	5.023
440	3.603	3.756	5.145
450	3.695	3.850	5.269
460	3.785	3.945	5.394
470	3.874	4.040	5.519
480	3.962	4.135	5.643
490	4.055	4.231	5.767
500	4.148	4.327	5.892
520	4.334	4.520	6.144
540	4.524	4.715	6.396
560	4.714	4.911	6.650
580	4.903	5.109	6.905
600	5.096	5.309	7.160
620	5.291	5.510	7.417
640	5.486	5.713	7.677
660	5.583	5.917	7.938
680	5.882	6.122	8.197
700	6.083	6.351	8.460
720	6.284	6.539	8.722
740	6.488	6.749	8.988
760	6.692	6.961	9.252
780	6.899	7.175	9.519
800	7.102	7.384	9.783
820	7.312	7.607	10.056
840	7.529	7.825	10.327
860	7.741	8.045	10.598
880	7.956	8.266	10.872
900	8.172	8.489	11.144
920	8.389	8.713	11.420
940	8.608	8.939	11.696
960	8.830	9.167	11.973
980	9.052	9.396	12.253
1,000	9.275	9.627	12.532
1,100	10.042	10.804	13.950
1,200	11.598	12.020	15.397

CG-064

617. Describe the procedures involved in inspecting conduits.

Inspection of Class A Conduits. Class A conduits have telltales and drain plugs installed at the top and bottom of the vertical centerline of the conduit seal plate. Telltales and drain plugs should be at least 1 inch in diameter. Telltales are inspected weekly, and leaks inside the casing can be detected by the discharge of steam through the telltales. When leaks are detected, they must be repaired. Following repair, the insulation in the casing must be thoroughly dried by circulating air through the airspace in the conduit. Leaks in the casing are detected by applying an air test of 15 psi to the conduit cavity. The casing should hold this air pressure for 15 minutes. If the air pressure does not hold, check for leaks by applying a soap and water solution to all accessible joints. If air is leaking from a joint, bubbles will form. Another test that is used to detect leaks is the odorization test. Close all drains and vents (except one vent) in the conduit and inject odorized air, under pressure, through the open vent. Leaks are detected by the odor of the escaping air. Inspect manholes monthly for accumulations of water.

Inspection of Class B Conduits. If leaks are suspected, drain all water from the conduit and turn on the HTW (or steam) line. The heat from the lines will dry out the insulation by evaporating the moisture. Air is circulated through the cavity by exhaust fans. After the insulation is thoroughly dry, then a visual inspection is made to determine leaks.

Exercises (617):

1. Describe the procedures involved in inspecting class A conduits.
2. Describe the procedures involved in inspecting class B conduits.

618. Identify the types of expansion joints, cite their purpose, and match the types of expansion joints with their description.

Purpose of Expansion Joints. Referring to table 1-2, a 300-foot length of steel pipe at 400° F. will expand 9.735 inches. The expansion rate of steel pipe at 400° F. is 3.245 inches for every 100 feet of piping, so

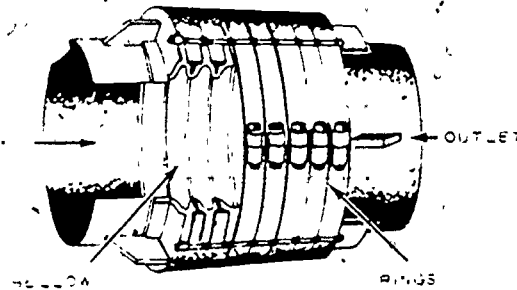


Figure 1-23. Bellows-type expansion joint.

the formula is: $\frac{300}{100} \times 3.245 = 9.735$ inches.

Expansion joints or loops are installed in the piping to absorb the lengthwise expansion and contraction.

Bellows Expansion Joints. Figure 1-23 illustrates a bellows expansion joint. This joint has a stainless steel bellows which flexes when expansion occurs. The pipes should be supported and guided to keep misalignment to a minimum.

Expansion Loops. Expansion loops absorb the expansion by introducing U or Z loops in the-line. This is the most popular expansion joint for HTW and should be used when at all possible.

Ball-Type Expansion Joints. There are some ball-type expansion joints that are rated for use with HTW. These joints consist of four basic parts: the casing or the body which holds the gaskets and ball; the ball, a hollow fitting shaped like a ball at one end, and the other end adapted for welding to the pipe; two gaskets which hold the ball and provide the seal; and a retaining nut or flange to hold the ball and gaskets in the casing. The end of one of the two pipes being coupled is connected to the joint casing, and the end of the other to the ball. In operation, a ball joint accommodates movements of the pipes by providing a flexible articulation (30° to 40° total angular flex, plus 360° rotation or swivel motion). The movement of a ball joint compares closely to the human shoulder joint.

Exercises (618):

1. Identify the types of expansion joints.
2. What is the purpose of expansion joints?

3. Match the type of expansion joint with the correct description listed by placing the appropriate letter in the blank.

- 1. This is the most popular type of expansion joint for HTW. a. Bellows
- 2. This joint has a stainless steel bellows which flexes when expansion occurs. b. Ball joints
- 3. This joint consists of four basic parts: the casing, the ball, the gaskets, and the flange. c. Expansion loops

Ball joints. See that the joint is adequately packed. Adjust or replace gaskets, as required, to prevent leaks and obtain a free working joint.

Manufacturer's instructions. In all cases, manufacturer's instructions (when available) will be followed when you perform maintenance on expansion joints.

Exercises (619):

- 1. Describe the maintenance requirements for the various types of expansion joints.

619. Describe the maintenance requirements necessary for the various types of expansion joints.

Inspection of Expansion Joints. The expansion joints used for HTW systems are inspected annually.

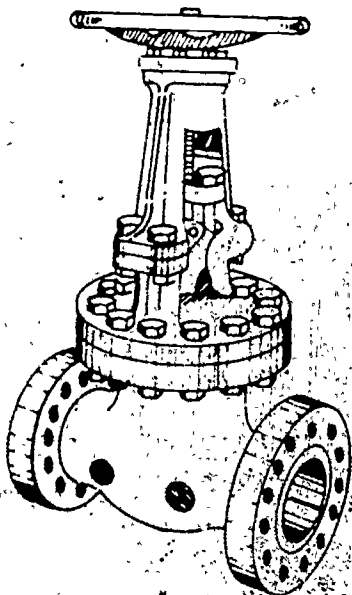
Bellows joint. Check bellows joints for misalignment, fatigue, corrosion, and erosion. Check the amount of travel of the bellows between cold and hot conditions. If the joint fails, replace the bellows section.

Expansion loops. Inspect for alignment. There are no other maintenance requirements for these loops.

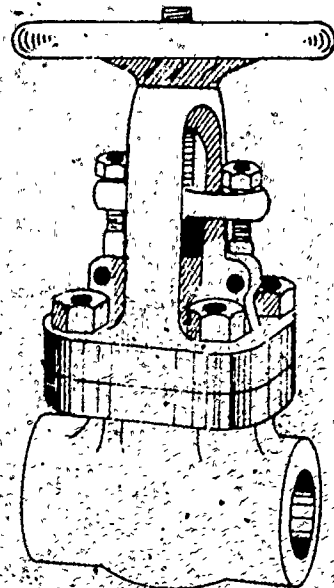
620. Answer key questions about the types of valves used in HTW heating systems.

Valve Bodies. All valves used in HTW systems should be constructed of cast steel bodies, stainless steel trim, and rated at a minimum of 300 pounds per square inch (psi) operating pressure. Valves larger than 2 inches (pipe size) are usually of the outside screw-and-yoke type with bolted bonnets (fig. 1-24). Smaller valves may be equipped with screwed bonnets.

Packing. The stuffing boxes should be large and deep. Valves smaller than 2 inches should have at least four or five rings of packing; larger valves must have a minimum of six rings.



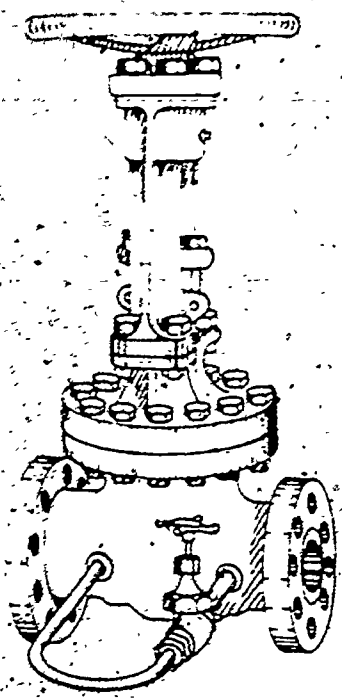
CKB-095A



CKB-095B

Figure 1-24. HTW valves.

363



CKB-096

Figure 1-25. HTW valve with bypass line.

of packing. The packing must be capable of withstanding the temperatures of HTW. All valves should be capable of being repacked while under operating pressures. Such valves are called back-seating. In operation, the valve seats when in the fully-open position, allows flow to pass through the seat and disc but prevents flow up the valve stem to the packing gland. Therefore, when in the fully opened position, the packing and the packing gland may be removed while the system is in operation.

Valve Design. Globe valves are the most common valves used on HTW systems. Gate valves should be used only as generator isolation valves, as they are not suitable for throttling. Valves 8 inches and larger should have an external bypass line (fig. 1-25) to prevent thermal shock and facilitate generator warmup.

Installation. Valves are connected to the HTW system through the use of welded flanges. This permits installation and removal of a valve in a short period of time with a minimum of tools.

Exercises (620):

1. What materials are used in the construction of HTW valves?

2. What is the minimum pressure rating of HTW valves?
3. Identify the types of bonnets used on HTW valves.
4. Compare the number of rings of packing used in HTW valves to the size of the rings.
5. Identify the type of valve that permits repacking while under system pressure.
6. What purpose do gate valves normally serve in an HTW system?
7. Name the device that helps to prevent thermal shock and facilitate generator warmup.
8. How are HTW valves connected to the distribution system?

621. Specify the periodic procedures for maintaining HTW heating system control valves.

Daily Maintenance. Daily maintenance of HTW valves consists of checking for leaks and damage to insulation. Leaking packing glands on valves cause corrosion to the valve and rapid deterioration to the insulation. Damaged or broken insulation is a source of heat loss and could burn personnel who come in contact with the bare piping.

Monthly Maintenance. On a monthly basis, you should operate and lubricate zone or branch line control valves. Also, lubricate exposed threads and gearing. These valves are rarely operated in normal operation, and the valve stem could become "frozen" in place, preventing opening and closing of the valve.

Annual Maintenance. Inspect and replace packing on an annual basis. Never replace one or two rings of packing. If a valve requires

repacking, remove and replace ALL of the packing. Whenever repacking is necessary, thoroughly clean the stem of the valve. A valve stem that is encrusted with seals or corrosion will cut up the new packing, destroying the seal. Be certain to stagger the cuts of the packing to provide a good seal. Tighten the packing gland nuts evenly and draw them up "snug." After the valve is repacked and the gland nuts properly tightened, operate the valve and check for binding and leaks.

Exercises (621):

1. Specify the procedures for maintaining HTW heating system control valves at each of the following periods of time:
 - a. Daily.
 - b. Monthly.
 - c. Annually.

COA
-11-
1-11-11

365

Steamplant Operation

YOU HAVE probably heard about steam and steampower most of your life but never realized just how ancient the use of steam really is. The expansive power of steam was tried in various applications as long ago as the third century AD. One man, by the name of "Hero," used steam under pressure to operate a simple engine. Even though the use of steam started many centuries ago, it is just as modern as any other heating system today. The type of boiler we have today, however, was not developed until the 19th century. This development of the steam heating system marked another step forward in the improvement and development of the heating processes, and it has kept pace with the other systems in the heating group. This is true because the steam heating system also has its special advantages, and it fits in with certain heating requirements.

In this chapter, you study about the construction of boilers, boiler designs and boiler components, feedwater units, pumps, steamplant operation, and operating logs. You are interested, we know, in doing your very best as a heating systems specialist. Consequently, you will be very interested in the information contained in this chapter. What you learn here may save your boiler and even your life. What are steam boilers? Our first discussion will tell you what they are.

2-1. Boiler Designs

The word "boiler" is commonly applied to a closed vessel used for generating steam. This steam generation is usually done under pressure. Since most boilers are used to produce steam, all boilers are generally thought of as steam boilers unless they are designated otherwise. In defining a boiler, you could say "a boiler is a closed vessel in which steam is generated as a result of the combustion of fuel." The term "steam generating unit" more accurately describes the present-day equipment. These steam

generator units normally include all of the accessories—from fans, feed pumps, and fuel burners to feedwater heaters and economizers.

622. Answer key questions about the various types of boilers used by the Air Force.

Today, central steamplants are used to furnish steam to the hospitals for sterilization purposes, dining halls, laundries, and other types of facilities on Air Force bases. The term "central steamplant" usually means that the plant serves more than one building. A central heating plant has one or more boilers which burn gas, oil, or coal as fuel. The steam or high temperature water that is generated is used for cleaning, sterilizing, cooking, and laundering operations. Small heating boilers play an important part in steam production. Frequently, they are used to provide steam and hot water for small buildings. Small units can also be used to supply the steam needed to operate mobile emergency power equipment.

Construction of Boilers. Boilers are constructed in many shapes and sizes. Of course, the greater the steam capacity, the larger the boiler. All boilers are constructed to incorporate a furnace or firebox for burning the fuel; also they have provisions for passing hot gases over the heat-absorbing surfaces. The heat-absorbing surfaces are designed to have the hot gases on one side and the boiler water on the other.

In most cases, baffles are provided in the boiler to guide the gases over the most effective route. These baffles also prolong the exit of the gases from the furnace so that the maximum amount of heat can be absorbed by the water. Boilers are equipped with doors and access panels so that the tubes and firesides of the boilers can be cleaned. Plugs, handholes, and manholes are also provided so that the watersides of the boiler can be

reached for cleaning. Access doors are usually sealed or made airtight by the installation of asbestos rope or webbing around the door. Manholes and handholes have gaskets made of asbestos and fiber to seal around these openings. These gaskets usually are replaced when annual maintenance is performed or when a leak occurs at either the manhole or the handhole that cannot be stopped by tightening the holding nut.

Many low-pressure boilers are constructed of cast-iron sections that are bolted together. The capacities of these boilers can be increased by adding more sections. Other types of low- and high-pressure boilers are made of good quality sheet steel. These boilers consist of sections of sheet steel formed to the required shape and electrically welded or riveted together. The common practice is for low-pressure boilers to be electrically welded and high-pressure boilers to be riveted.

Types of Steam Boilers. Steam boilers made of cast iron and others constructed of steel are normally further classified into two general types: fire-tube and water-tube. Fire-tube boilers were first used many centuries ago, but water-tube boilers were not used until the 18th century.

Fire-tube boilers. Fire-tube boilers are those in which the byproducts of combustion

pass through the tubes, and water surrounds these tubes. Fire-tube boilers of small and medium size usually have a metal-walled combustion chamber that is integral with the boiler. Because of their ease of installation, fire-tube boilers are the most popular type of steel boiler for low-pressure and low-capacity purposes. Their design and construction, however, are such that there is a definite limitation in the size and pressure for which they can be built. They are seldom used when requirements are above 150 psi design pressure. Their overload is limited, and exit gas temperature rises rapidly with an increased output. One advantage is the large water storage capacity of this boiler. Because of this feature, wide and sudden fluctuations in the steam demand are met with little change in pressure.

A boiler that has the combustion chamber incorporated as an integral part of the boiler is usually referred to as a firebox boiler. Firebox boilers require no masonry setting, except perhaps an ashpit or floor for the combustion chamber. Combustion gases travel from the firebox through the boiler tubes to a smokebox at the back of the boiler. Then, they return through the second set of boiler tubes to the front of the boiler from which they are discharged to the breeching or the smoke pipe (uptake).

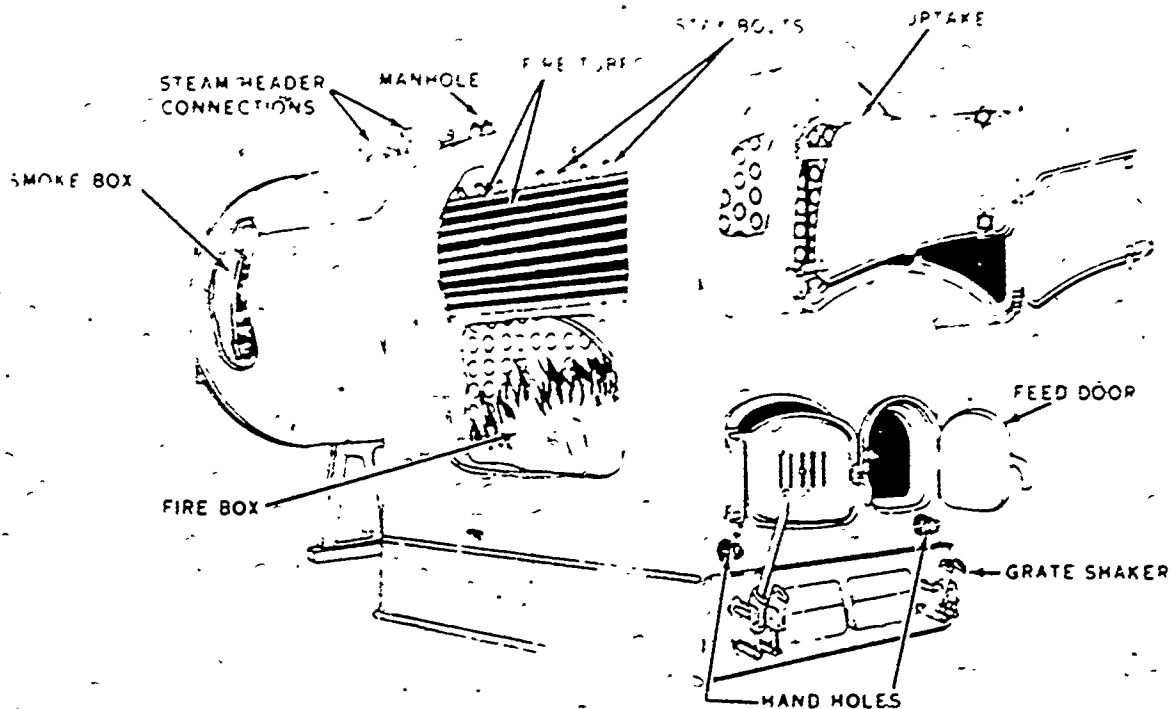


Figure 2-1. A locomotive boiler.

367

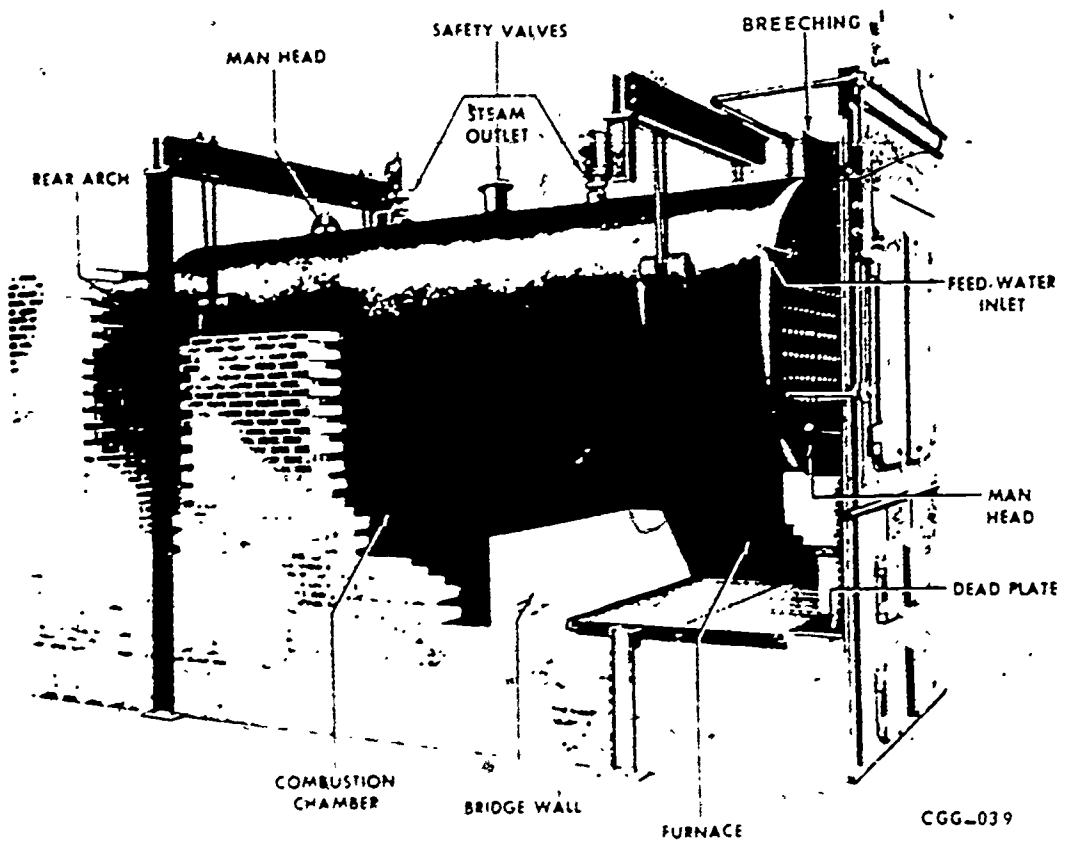


Figure 2-2. A horizontal-return tubular boiler.

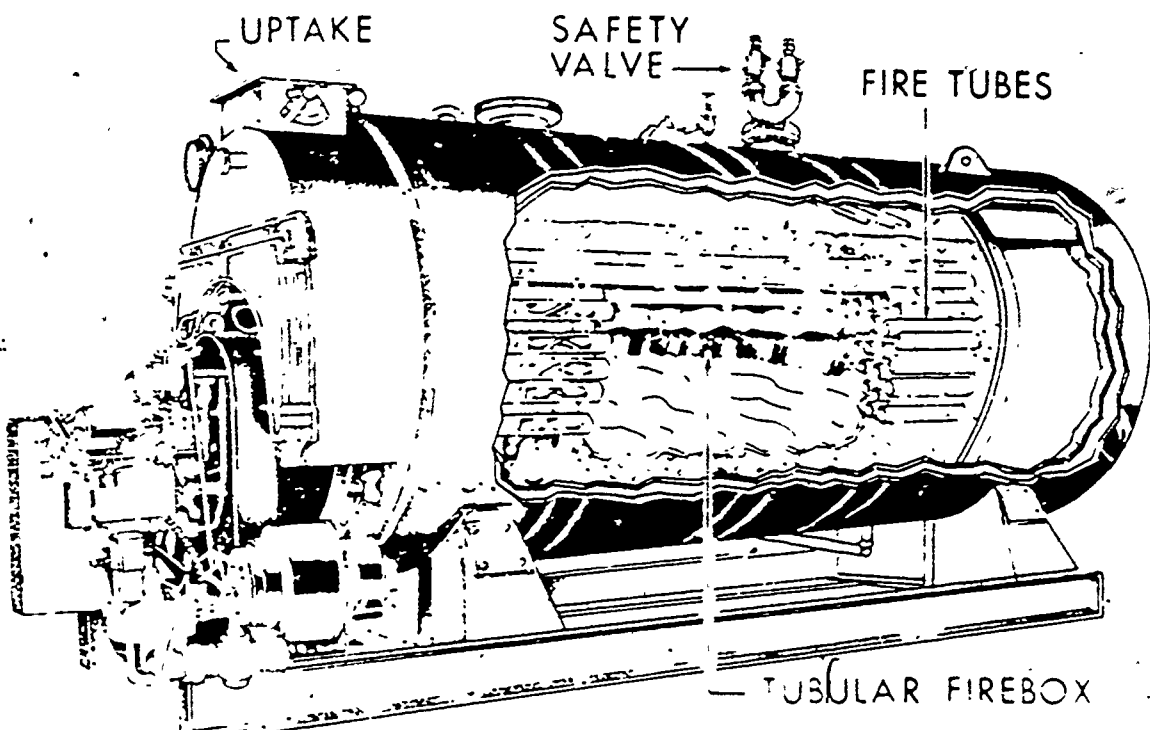
There are three classes of fire-tube boilers: the locomotive, the tubular, and the Scotch marine. Any of these boilers can be of single- or double-pass construction. There are many versions of these three classes of boilers. Some of the boilers are built to operate on the vertical position instead of in the conventional horizontal position.

a. Locomotive boiler. The locomotive boiler, shown in figure 2-1, has a steel firebox consisting of inner and outer sheets that are held together with staybolts. The bolts consist of threaded rods that are screwed through threaded holes in the boiler metal sheets and hold them rigid. All four sides of the firebox are surrounded by water. The top metal sheet of the firebox is called the crown sheet, and it is supported away from the shell by crown staybolts and crown bolts. These crown sheets should be inspected periodically for leaks, deterioration, and leaking crown staybolts or crown bolts. This type of boiler is very similar in construction to the boiler used on locomotives.

The locomotive boiler has water legs that extend down the sides of the firebox. They also serve as collecting places for the sediment

that precipitates out of the boiler water. The water legs of the locomotive boiler are connected in the rear to the blowdown lines so that the sediment can be removed from the boiler. This prevents damage to the boiler from hot spots created by accumulated sediment keeping the water away from the heating surfaces of the water legs. You will notice that the boiler shown in figure 2-1 has handholes for accessibility in cleaning the water legs. There is also a manhole in the top of the shell for access to the watersides.

b. Tubular boiler. The horizontal-return tubular boiler, often called the HRT boiler, is used for industrial heating (see fig. 2-2). This boiler is round and has one or two sets of tubes extending throughout its length. The firebox must be constructed separately of firebrick. Approximately one-half of the boiler extends beyond the firebox. Large boilers are supported from the floor by four columns, with the firebrick forming four sides of the firebox. The initial cost of the HRT boiler is relatively low, and it is not difficult to install. The boiler setting can be readily changed to meet different fuel requirements—coal, oil, wood, or gas. Tube replacement is also a comparatively easy task,



FUEL BURNING EQUIPMENT

CGG 025

Figure 2-3. A Scotch marine boiler.

since all tubes in the HRT boiler are the same in size, length, and diameter.

The gas flow in the HRT boiler is from the firebox toward the rear of the boiler, where the gases are directed upward to the tubes by means of refractory baffle. Then it returns through the tubes to the front of the boiler where it is discharged to the breeching, as shown in figure 2-2. The HRT boiler has a pitch of 1 to 2 inches to the rear. This allows sediment to settle toward the rear. The fusible plug of the boiler is located 2 inches above the top row of tubes. Boilers over 40 inches in diameter require a manhole in the upper part of the shell. Those over 48 inches in diameter must have a manhole in the lower as well as the upper part of the shell. Don't fail to familiarize yourself with the location of these and other essential parts of the HRT boiler.

c. Scotch marine boiler. The Scotch marine boiler, shown in figure 2-3, is popular because of its compactness. It is tubular in shape and has a built-in firebox that extends lengthwise through its center. The Scotch marine boiler is a portable or package unit and can be moved with ease. It needs a minimum of foundation work. It is a complete, self-contained unit which includes automatic controls, steel boiler, and burner

equipment. These features are advantageous because no disassembly is required when you have to take the boiler to the field for emergency uses or move it to a more suitable location in the area.

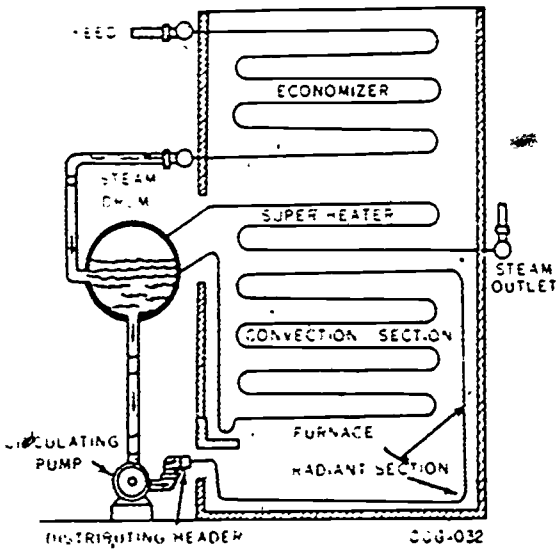


Figure 2-4. A schematic of a forced-circulation steam boiler.

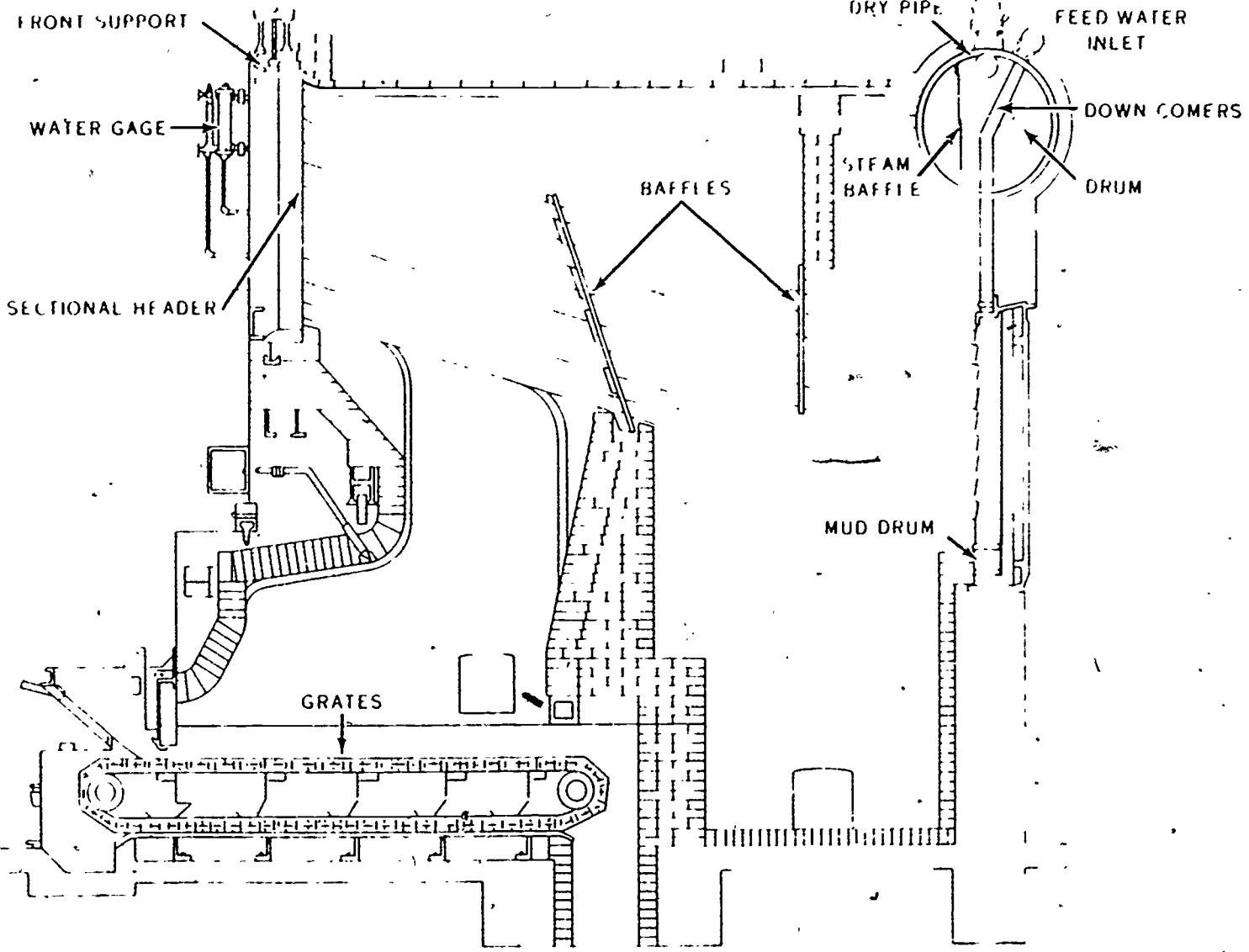


Figure 2-5. A sectional-header cross-drum boiler.

The Scotch marine boiler has a two-pass arrangement of the tubes, which run horizontally. This allows the heat inside the tubes to travel back and forth. It also has an internally fired furnace with a cylindrical combustion chamber. Its corrugated, sheet-metal firebox makes suitable provision for expansion. There is also a flue gas outlet, or smoke breeching, located on the front end of the boiler. Oil is the fuel commonly used to fire the Scotch boiler. When desirable, though, it can be fired by gas or coal.

Major advantage of the Scotch boiler over a water-tube boiler is that it requires less space and can be set up in a room with a low ceiling. The fact that its tubes are all the same size saves time and trouble in making tube replacements. The Scotch boiler has a few disadvantages. Its shell is from 6 to 8 feet in diameter and makes a large amount of reinforcing necessary. The fixed dimensions of its internal furnace create some difficulty in cleaning the surface of the section located below the combustion chamber. Another drawback is the limited capacity and pressure of the Scotch boiler.

The Scotch marine boiler is self-supporting. The shell rests in two or more cast-iron cradles, and the boiler pitches 1 to 2 inches toward the rear. The boiler includes a blowdown pipe that is screwed into a pad riveted to the bottom of the shell. The flow of gases in the Scotch marine boiler is toward

the rear of the combustion chamber; then they return by way of the tubes to the front and go out into the smokebox and stack breeching. The fusible plug of the Scotch boiler is usually located in the crown sheet. However, it is sometimes found in the upper back of the combustion chamber. The fusible plug will be discussed in more detail later in this chapter.

Access for cleaning and repairing the boiler is provided through a manhole in the top of the boiler shell and a handhole in the water legs. The manhole is an opening large enough for a man to enter the boiler shell for inspection and cleaning purposes. For the safety of the man inside, make sure that all valves are secured, locked, and tagged, and that the man in charge knows someone is in there. A man must also be stationed at the outside entrance to aid and assist. The handhole is an opening large enough to permit hand entry for cleaning, inspecting, and repairing the headers and tubes.

Water-tube boilers. Steel boilers in which the water circulates inside of boiler tubes located in the path of the flue gases are water-tube boilers. These boilers avoid the use of large, flat, steam-containing surfaces; they can be designed for use at high pressures with safety. The boiler has the further advantage of being easier to clean than fire-tube boilers. Because they require much masonry construction at the time of installation, they

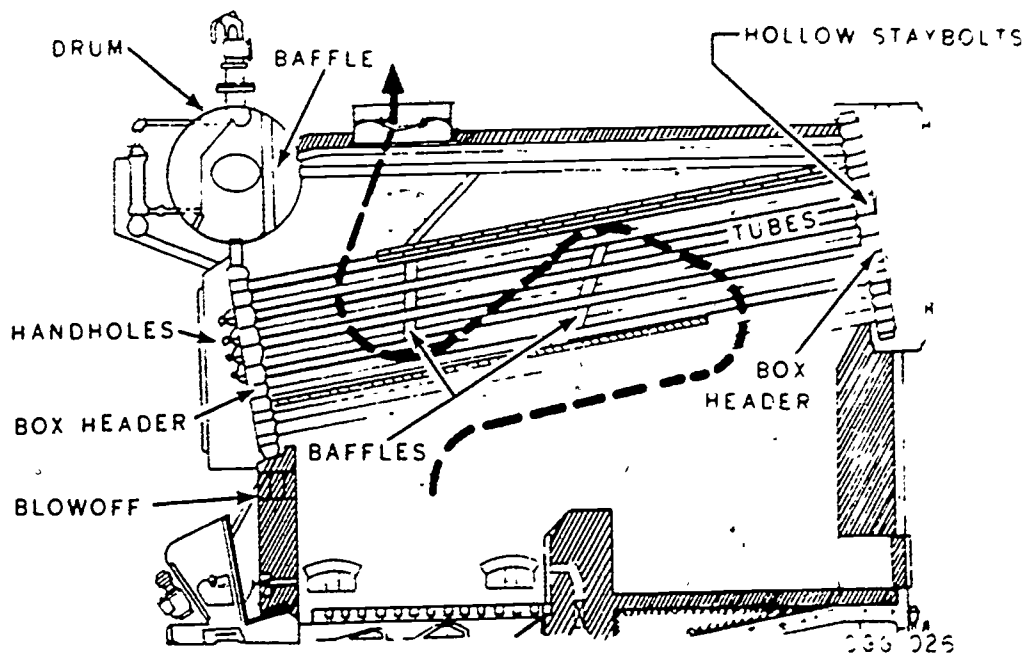


Figure 2-6. A box-header cross-drum boiler

are more expensive than the fire-tube boilers and are seldom used, except the large sizes. Water-tube boilers can be classified according to the details of construction, size, arrangement of tubes, method of circulation, and other special design features.

All boilers having tubes 2 inches or more in diameter are classified as large tube boilers. Boilers having tubes less than 2 inches in diameter are small tube boilers and are commonly called the express type. Practically all of the modern steam boilers are the express type. Water-tube boilers are end-fired, side-fired, single- or double-uptake,

371
air-encased, and are divided heating units. The modern boilers, of the express type, employ either natural or forced circulation to move the boiler water. Natural circulation depends upon the difference in density of the water caused by the heat absorbed by the boiler tubes. The water in a forced circulation steam boiler depends upon external pumps to provide the circulation. These pumps provide a mechanical heat which maintains continuous flow of water through the boiler circuits. A schematic of a steam boiler of the forced-circulation type is shown in figure 2-4.

The types of tube arrangements used in

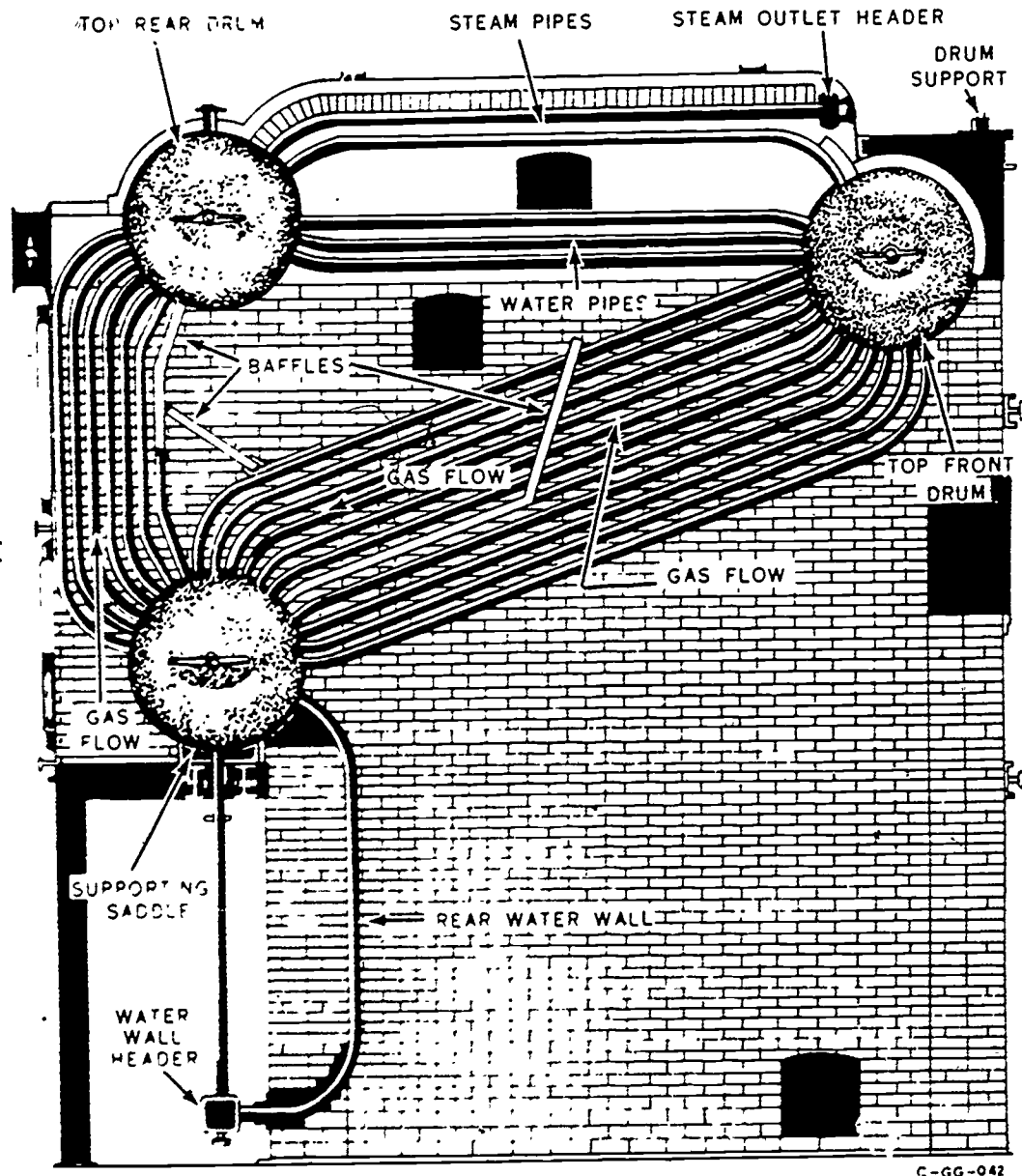


Figure 2-7. A typical bent-tube boiler.

water-tube boilers are straight, bent, and coiled. Modern boilers are usually of the bent-tube type. In this course, we discuss only the straight-tube and bent-tube arrangements. These arrangements are discussed separately in the paragraphs that follow. To avoid confusion, you should study carefully each illustration referred to throughout the discussion. The straight-tube arrangement of water-tube boilers includes three types: sectional-header cross-drum, box-header cross-drum, and box-header longitudinal drum.

first type, shown in figure 2-5 is a sectional-header cross-drum boiler that has vertical headers. The headers are steel boxes into which the tubes are connected. Feedwater enters the drum and passes down through the pipes (downcomers) into the rear sectional-headers from which the water tubes are supplied. As the water is heated, some of it changes into steam and flows through the tubes to the front headers. The steam-water mixture then returns to the steam drum through the circulating tubes and is discharged in front of the steam-drum baffle. This baffle helps to separate the water from

a. Sectional-header cross-drum boiler. The

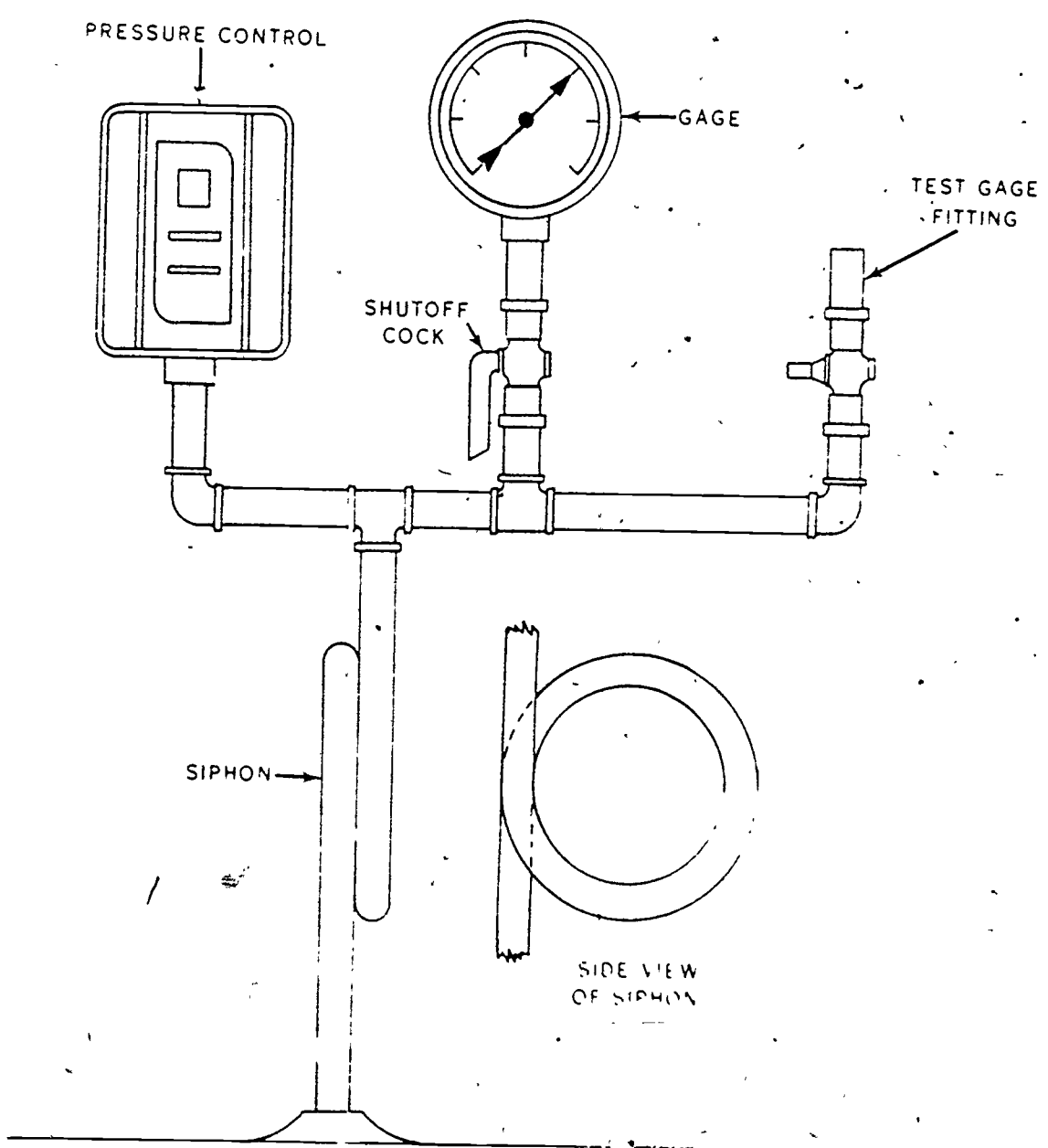


Figure 2-8. A typical steam gage installation.

373

the steam. The steam is released from the top of the drum through the dry pipe. This pipe extends along the length of the drum and has holes or slots in the top half through which the steam enters. This helps to prevent water from being carried into the steam lines.

Headers are distinguishing features of the sectional-header cross-drum boiler. They are usually made of forged steel and are connected to the drums by the tubes. The headers are connected at right angles to the tubes, as shown in figure 2-5. The tubes are rolled and flared into each header. A handhole is located opposite both ends of each tube to facilitate inspecting and cleaning. A mud drum is connected, by short nipples, to the bottom of each rear header. Its purpose is to collect sediment, which is removed by blowing down the boiler. Baffles are usually arranged so that the gases are directed across the tubes at least three times before they are discharged from the boiler below the drum.

b. Box-header cross-drum boiler. The box-header cross-drum boiler is the second type, and it is illustrated in figure 2-6. The box-headers are shallow boxes made of two metal plates: (1) a tube-sheet plate, which is bent to form the sides of the box, and (2) a plate containing the handholes, which is riveted to the tube-sheet plate. The tubes enter at right angles to the box-header and are expanded and flared in the same manner as in the sectional-header boiler. The boiler is usually built with the drum located in front. This boiler has either cross or longitudinal baffling that is arranged to divide the boiler into sections which force the flue gases to make three passes. Water enters the bottom of the drum, flows through connecting tubes to the box-header, moves through the tubes to the rear box-header, and goes back to the drum.

c. Box-header longitudinal-drum boiler. The third type is the box-header longitudinal-drum boiler, which has either a horizontal or an inclined drum. Box-headers are fastened directly to the drum when the drum is inclined. If the drum is horizontal, the front box-header is connected to it at an angle greater than 90°. The rear box-header is connected to the drum by tubes. Longitudinal or cross baffles can be used with either type.

Boilers of the bent-tube type usually have three drums, each the same in diameter but not all set on the same level. The tubes are bent at the ends to enter the drums radially. A typical bent-tube boiler is shown in figure 2-7. Water enters the top rear drum, passes through the tubes to the bottom drum, and then moves up through the tubes to the top

front drum. A mixture of steam and water is discharged into this drum; the steam returns to the top rear drum through the upper row of tubes while the water travels through the tubes in the lower rows. The steam is removed near the top of the rear drum by tubes extending across the drum, and it enters a small collecting header above the front drum.

Many baffle arrangements are used with bent-tube boilers. Usually, the baffles are installed so that 70 to 80 percent of the heat will be absorbed by the inclined tubes between the lower and upper front drums.

Water-tube boilers offer a number of worthwhile advantages. For one thing, they afford flexibility in starting up. They also have a high productive capacity, which ranges from 100,000 to 1,000,000 pounds of steam per hour. In case of tube failure, there is little danger of a disastrous explosion of the water-tube boiler. The furnace not only can carry a high overload, it can also be modified easily for firing by oil or coal. Still another advantage is afforded by the minimum of difficulty encountered in getting to the sections inside the furnace for cleaning and repairing.

There are several disadvantages that are common to water-tube boilers. It should be pointed out here that high construction costs are involved, which is one of the major drawbacks to using water-tube boilers. The large assortment of tubes required of this boiler and the excessive weight per unit weight of steam generated are also other unfavorable factors.

Exercises (622):

1. What is the advantage of using central steamplants on an Air Force base?
2. Why is it necessary to provide steam for hospitals?
3. Why are baffles installed in the furnace of a boiler?
4. Why are sections added to cast-iron boilers?
5. Why are some boilers called the fire-tube type?

- 6. Identify the three classes of fire-tube boilers.
- 7. Why is the Scotch marine boiler preferred to a water-tube boiler?
- 8. Why are some boilers called the water-tube type?
- 9. Identify the types of water-tube boilers that have straight tubes.
- 10. If you had a demand for 900,000 pounds of steam per hour, what type of boiler would you most likely choose.

623. Describe the functions of boiler accessories and answer key questions about them.

Now that you have a general idea of the overall basic structure of a boiler, several questions no doubt have come to your mind. You are probably wondering about the importance of certain boiler parts and the operation or function of various devices, such as controls, valves, try cocks, and the like. Thus, a sufficient number of essential accessories and fittings are discussed to provide you with a background for further study. As a reminder, and in case you should run across some unit or device not covered in this chapter, check the manufacturer's manual for information on the details of its construction and its method of operation. The term "fittings" pertains to the various controlling devices installed on the boiler. Bear in mind that the fittings are vitally important to the economy of operation and safety of personnel and equipment. A thorough knowledge of fittings is necessary if you are to acquire skill in the installation, operation, and servicing of steam boilers.

Steam Gage. The steam gage is located on top of the boiler, as illustrated in figure 2-8, and is used to indicate the pressure of steam in the boiler. It must be accurately calibrated and have a siphon loop between the boiler

and gage. This loop prevents live steam from coming in direct contact with the gage mechanism and prevents damage to the gage. The steam gage is installed so that it can be shut off from the boiler by a cock placed near the gage. This cock has a tee or lever handle which is parallel to the pipe in which it is located when the cock is open.

Provisions should be made so that a test gage can be installed to check the accuracy of the regular gage while the boiler is in service. The gage dial is usually graduated to read approximately twice the pressure at which the safety valve is set; it is never graduated to read less than 1 1/2 times this pressure. Most of the gages used by the Air Force on boilers are of the Bourdon type. They contain a Bourdon tube which operates the pointer.

Pressure Control. Pressure controls are designed primarily for steam heating systems but are also available for controlling air, liquids, or gases that are not chemically injurious to the control. The purpose of the pressure control is to control the pressure in the boiler, to secure the fuel-burning equipment when the pressure reaches a predetermined cutout, and to start the fuel-burning equipment when the pressure drops to the cut-in point. There are two settings on the pressure control: the cut-in point and the differential. To find the cutout point, you add the differential to the cut-in pressure. For example, if you were operating a boiler with a cut-in pressure of 90 pounds and a differential of 13 pounds, the cutout pressure should be 103 pounds. When excessive vibrations are encountered, you should mount the pressure control remotely from the boiler on a solid mounting with a suitable piping connection between them. Pressure controls that are located remotely from the boiler must be installed at a slightly higher level than that shown in figure 2-8. The piping must be properly pitched to drain all condensation back into the boiler. A siphon must be connected between the pressure control and the boiler.

When a mercury-type switch control is used, be sure that it is mounted level and that the pig-tail siphon has the loop extending in the direction of the back of the control and at a 90° angle to the front. This prevents expansion and contraction of the siphon from affecting the level and accuracy of the control. The pressure control can be mounted either on a tee along with the pressure gage on the pressure-gage tapping, as shown in figure 2-8, or it can be mounted on the low-water cutout provided by some manufacturers. In either case, be sure that the pipe dope is not



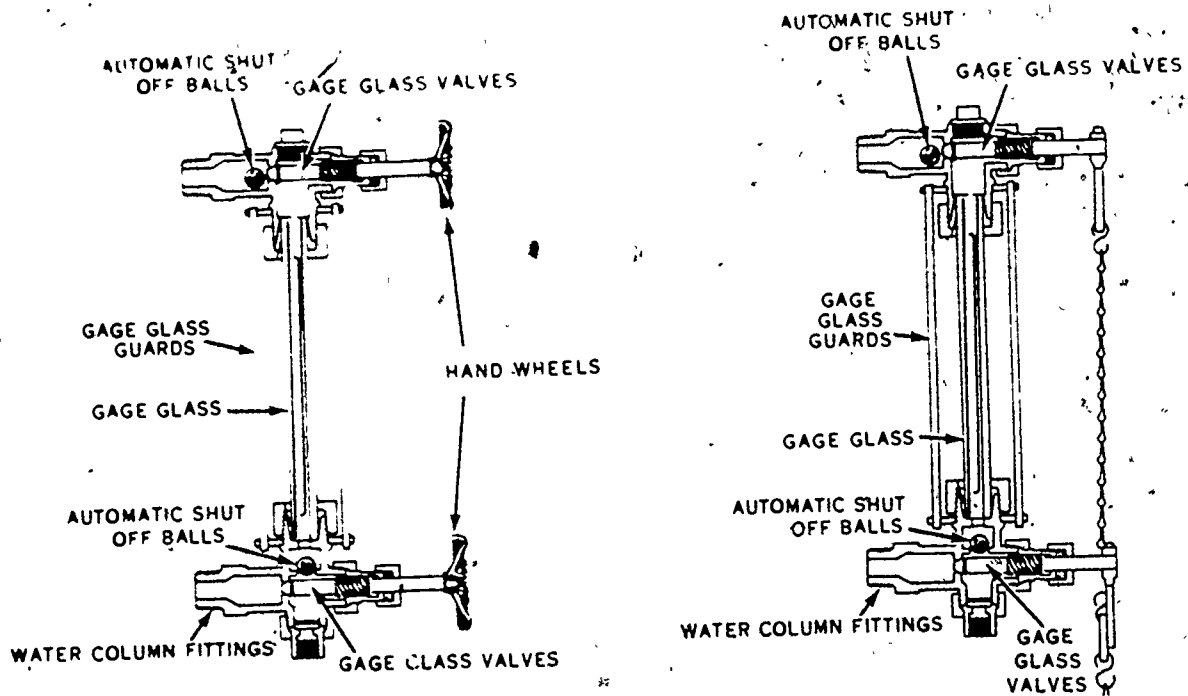


Figure 2-9. Gage glasses.

permitted to enter the control. Apply the dope to the male threads, leaving the first two threads bare.

Gage Glass. Each boiler must have at least one water-gage glass. If the operating pressure is 400 psi or more, two gage glasses must be

provided. This is required by the ASME (American Society of Mechanical Engineers) code. The gage glass allows you to tell, by sight, the water level in the boiler. Each gage glass must have a valved drain, and the gage glass and pipe connections must not be less

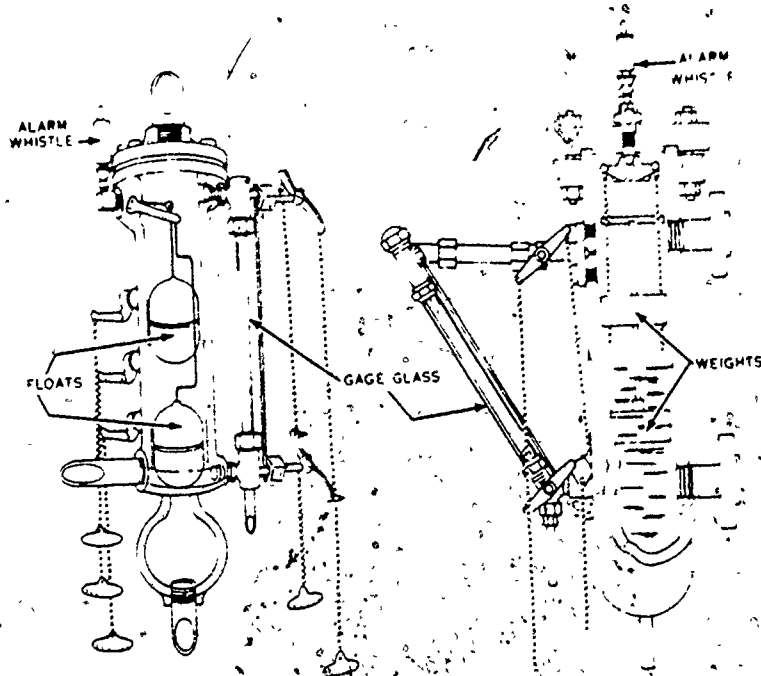


Figure 2-10. Water columns.

than 1/2-inch pipe size. The lowest visible part of the water gage must have a valved drain. The lowest visible part of the water gage must be at least 2 inches above the lowest permissible water level. This level is defined as the lowest level at which there is no danger of overheating any part of the boiler when in operation at that level. Horizontal fire-tube boilers are set to allow at least 3 inches of water over the highest point of the tubes, flues, or crown sheet at the lowest reading in the gage glass.

Water-gage glasses, shown in figure 2-9, are used with boilers operating at low and medium pressures. Each consists of a strong glass tube connected to the boiler or water column by two special fittings. These fittings sometimes have an automatic shutoff device, usually nonferrous balls, which function when the water glass fails. The top ball does not completely shut off the flow, and the bottom ball must rise vertically to the seat.

Unless two gage glasses are installed on the same horizontal line, each boiler must have three or more gages or try cocks located within the visible length of the gage glass to prove the boiler water level. The middle try cock is usually at the mean water level of the boiler. The other two are spaced equally above and below it; the actual distance depends upon the size of the boiler. Only two try cocks are required if the boiler is not over 36 inches in diameter and the total of the heating surfaces does not exceed 100 square feet. Gage cocks are used to check the accuracy of the gage glass and as shutoffs when the gage glass is broken. They are opened by means of a handwheel, chainwheel, or lever, and are closed by hand, by a weight, or by a spring.

Water Column. A water column is a hollow cast-iron, malleable-iron, or steel vessel that has two connections to the boiler, as illustrated in figure 2-10. The main purpose of the water column is to help prevent fluctuation of the water level in the gage glass. The top connection enters the steam space of the boiler through the top of the shell, or head, and the water connection enters the shell, or head, at least 6 inches below the lowest permissible water level. The pipe used to connect the water column to the boiler may be brass, iron, or steel, depending on the pressure requirement. It must be at least 1 inch in diameter.

Valves or cocks are used in these connecting lines if their through-blow

construction prevents stoppage by deposits of sediment and if the position of the operating mechanism indicates whether they are open or closed. A valved drain or blowdown line (1/4-inch pipe size or larger) is connected to the water column for the removal of mud and sediment from the lines and the column. The water columns, illustrated in figure 2-10, are equipped with high-water and low-water alarms, which sound a whistle to warn the operator. The whistle is operated by either of the two floats or solid weights.

Safety Valve. Safety valves are installed to relieve excessive pressures in the boiler. Their construction, installation, and performance are rigidly prescribed in the boiler ASME code. Each boiler that has more than 500 square feet of heating surface must have two or more safety valves installed. No valve or stopcock will be installed between the boiler and the safety valve. The discharge line is supported separately to prevent any undue stress on the valve. The capacity of the safety valve must be sufficient to discharge all of the steam generated by the boiler without

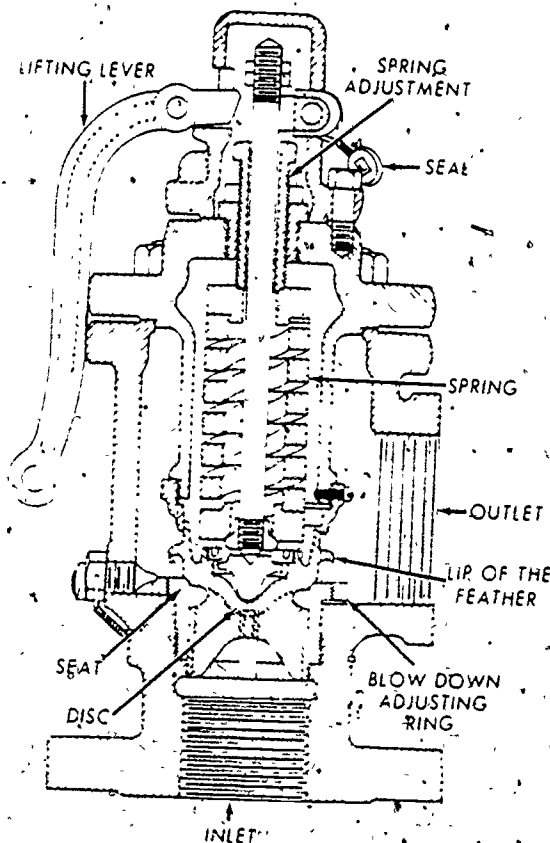


Figure 2-11. A spring-loaded safety valve.

allowing the pressure to rise more than 6 percent above the maximum working pressure. Safety valves should be popped monthly by hand to insure that they are not sticking and that they operate freely. They should also be opened periodically by building up the steam pressure to the relieving point and causing them to open by steam pressure to insure that they are opening at the correct pressure.

The spring-loaded safety valve is often called a pop-off valve because of the characteristic sound it makes when it opens. The safety valve is equipped with a lever for manual operation. A typical spring-loaded safety valve is illustrated in figure 2-11. The force of the compressed spring keeps the valve closed against the force developed by the steam pressure within the boiler. When the steam pressure rises to a point greater than that of the compressed spring, the valve will pop open. The valve will remain open until the pressure within the boiler drops below the set pressure. The setting and adjustment of safety valves are done by authorized personnel only. All safety valves should be properly sealed to prevent tampering the adjustment.

Fusible Plug. The fusible plug is designed to give additional protection to the boiler against low water. The plug is installed so that the largest area of the core is exposed to the water for cooling. The core of a fusible plug is made of tin, copper, and lead. Fusible plugs are of two types: fire-actuated and steam-actuated. A fusible plug should be replaced every 12 months. If the core of the

plug is exposed to heat for longer periods of time than this, it has a tendency to harden and to lessen or remove its value as a safety device. Too high a temperature would then be required to melt the core in the event of loss of water in the boiler. When the core melts, steam escapes and warns the operator.

The fire-actuated fusible plug is generally screwed into the boiler shell about 2 inches above the top row of tubes or at the lowest permissible safe water level. The boiler must be shut down to replace the fusible plug. The steam-actuated type of fusible plug is screwed into the end of a special tube that extends down into the water to the lowest permissible safe water level. When the water level drops below the end of this tube, steam enters the tube and melts the core. When the core melts, the steam rushes out of the tube and warns the boiler operator. A stop valve is usually installed in the tube between the plug and the boiler. This is done so that the plug can be replaced without taking the boiler out of service.

Feedwater Control. The boiler feedwater control unit is provided to maintain a fixed water level and thereby protect the boiler from feedwater failure. This unit consists basically of an enclosed float-actuated valve, an electrical switch, or a combination of both, mounted on the outside of the boiler near the water-sight gage. The feedwater control unit adds water to a boiler by opening a water valve or operating a water pump. It eliminates a high-water line by actuating an overflow valve. The control provides for ringing a bell when the water in the boiler becomes dangerously high or low. The unit also stops the operation of a stoker, oil, or gas burner when the water line is low.

Blowdown System. All steam heating systems must have the provision to blow down the boiler. The amount of blowdown is indicated by the results of the total dissolved test. The object of blowing down the boiler is to remove sediment such as mud, scale, and other impurities that are harmful to the boiler. Blowdown is also used to remove excess water from the boiler. The blowdown system is usually connected to the lower tapping on the boiler and consists of a slow-opening valve, a quick-opening valve, a flash tank, and the necessary piping, as illustrated in figure 2-12.

When a boiler is blown down, the quick-opening valve is opened first and the slow-opening valve is opened second. The reason for doing this is to avoid undue stress

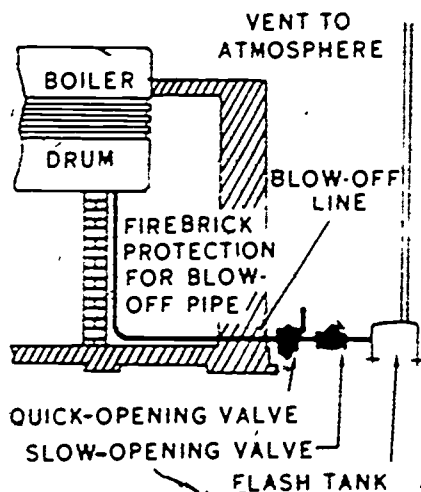


Figure 2-12. A typical blowdown system.

NATIONAL BOARD

35678
KEWANEE
125 lbs
715 HS
1947

Boilers are also stamped with the manufacturer's stock number, boiler size, and the dry weight of the boiler. For example:

08360
583
13770 lbs

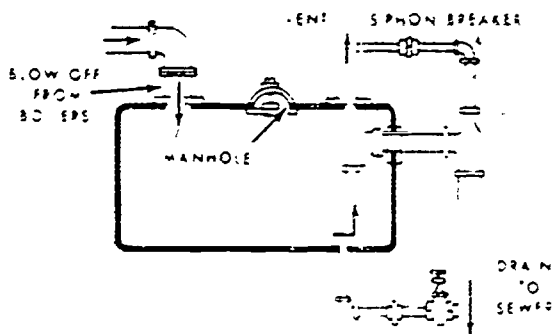


Figure 2-13. A flash tank arrangement.

on the boiler and the blowdown piping. When sufficient blowdown time has elapsed, the slow-opening valve is closed first and the quick-opening valve is closed last.

The blowdown water or steam should never be piped directly into the atmosphere or sewer because of the possibility of injuring people and damaging the sewer connections. The correct method of disposing of this hot water and steam is by the use of a flash tank, sometimes called a blowdown basin. (See fig. 2-13.) This tank is usually buried underground to prevent freezing. It is equipped with a bottom drain for emptying the tank when cleaning is necessary. A manhole is also provided for cleaning and inspecting purposes.

When the hot water from the boiler enters the flash tank, part of the water flashes into steam and is vented into the atmosphere. The water that does not flash into steam, however, will raise the water level in the tank and cause cold water in the tank to overflow into the sewer.

The ASME Boiler and Pressure Vessel Code, sponsored by the American Society of Mechanical Engineers, requires that all boilers carrying over 100-psi working pressure (except traction or portable boilers) have two blowdown valves on each blowdown pipe. The arrangement may include two slow-opening valves or one slow-opening valve and a plugcock. Traction and portable boilers must have one slow- or one quick-opening blowdown valve. All types of boilers must have the blowdown valves installed with extra heavy steel or malleable iron piping.

Boiler Identification Markings. Each boiler is stamped with a National Board number, manufacturer's name, steam working pressure, number of square feet of heating surface, and the year it was built. For example:

Pipe Identification Markings. Boilerroom piping is usually painted different colors to identify the contents that flow through the pipes. It is recommended that the heating operator acquaint himself with the color code used in his particular installation.

Exercises (623):

1. Describe the function of the steam gage installed on the boiler.
2. What is the purpose of siphon loops used with steam gages?
3. A steam boiler has a safety valve set at 50 psi. What should the highest reading of the steam gage be marked at?
4. Describe the function of the pressure control.
5. Why must the pigtail loop of the siphon be mounted so it is perpendicular (90° angle) to the front of the pressure control?

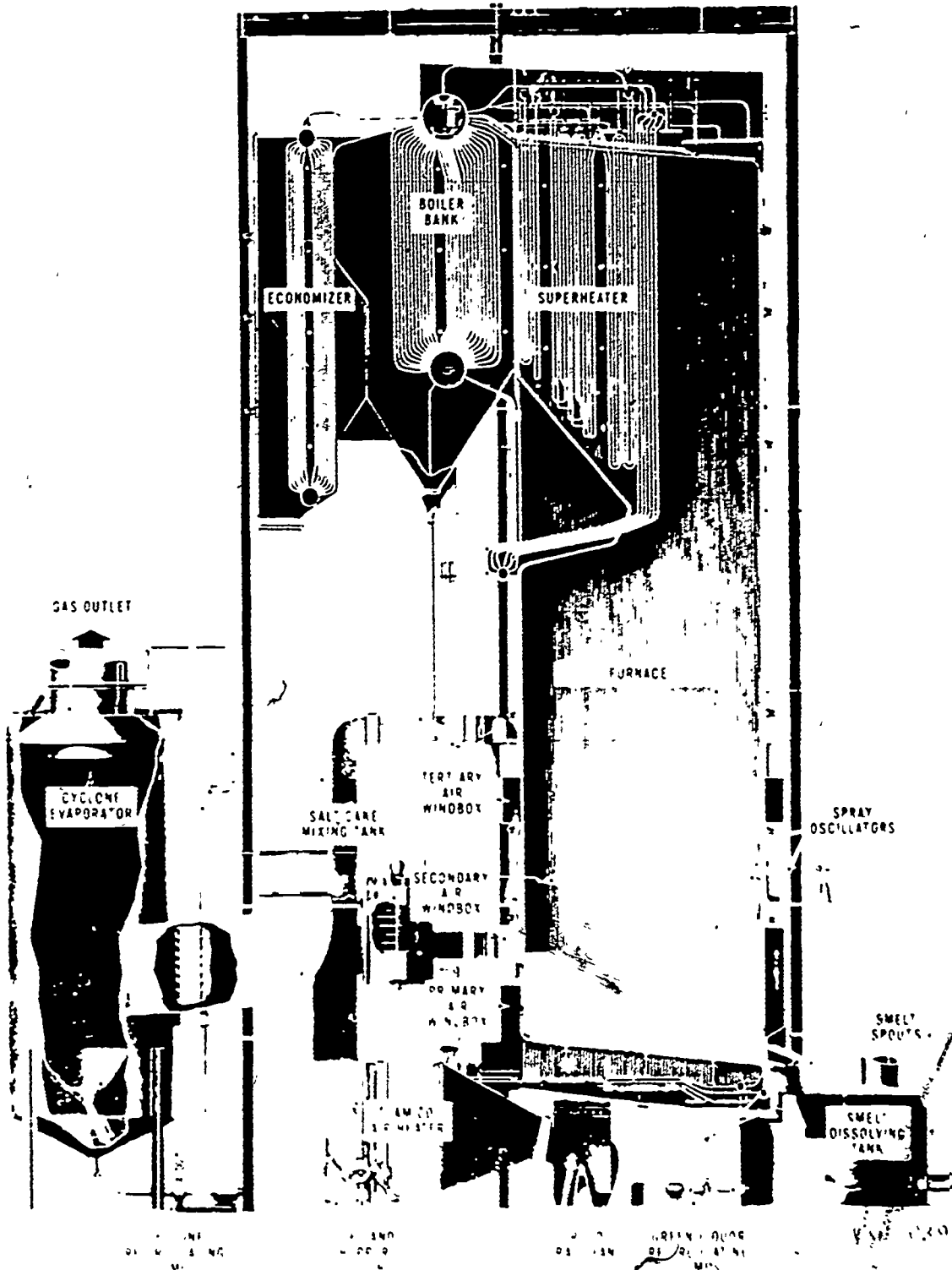


Figure 2-14. A typical pump and papermill recovery unit.

- 6. Why must two gage glasses be installed on boilers having over 400 psi?
 - 7. Describe the function of gage glasses installed on boilers.
 - 8. Describe the function of the water columns that are mounted on steam boilers.
 - 9. Why is a steam boiler equipped with a safety valve?
 - 10. Why are fusible plugs installed in boilers?
 - 11. What is the purpose of a flash tank?
 - 12. List the common boiler accessories that are used with steam boilers.
624. State the primary factors that must be known prior to installing boilers, and specify who furnishes the instructions and procedures for boiler installation.

Before a boiler can be installed, certain

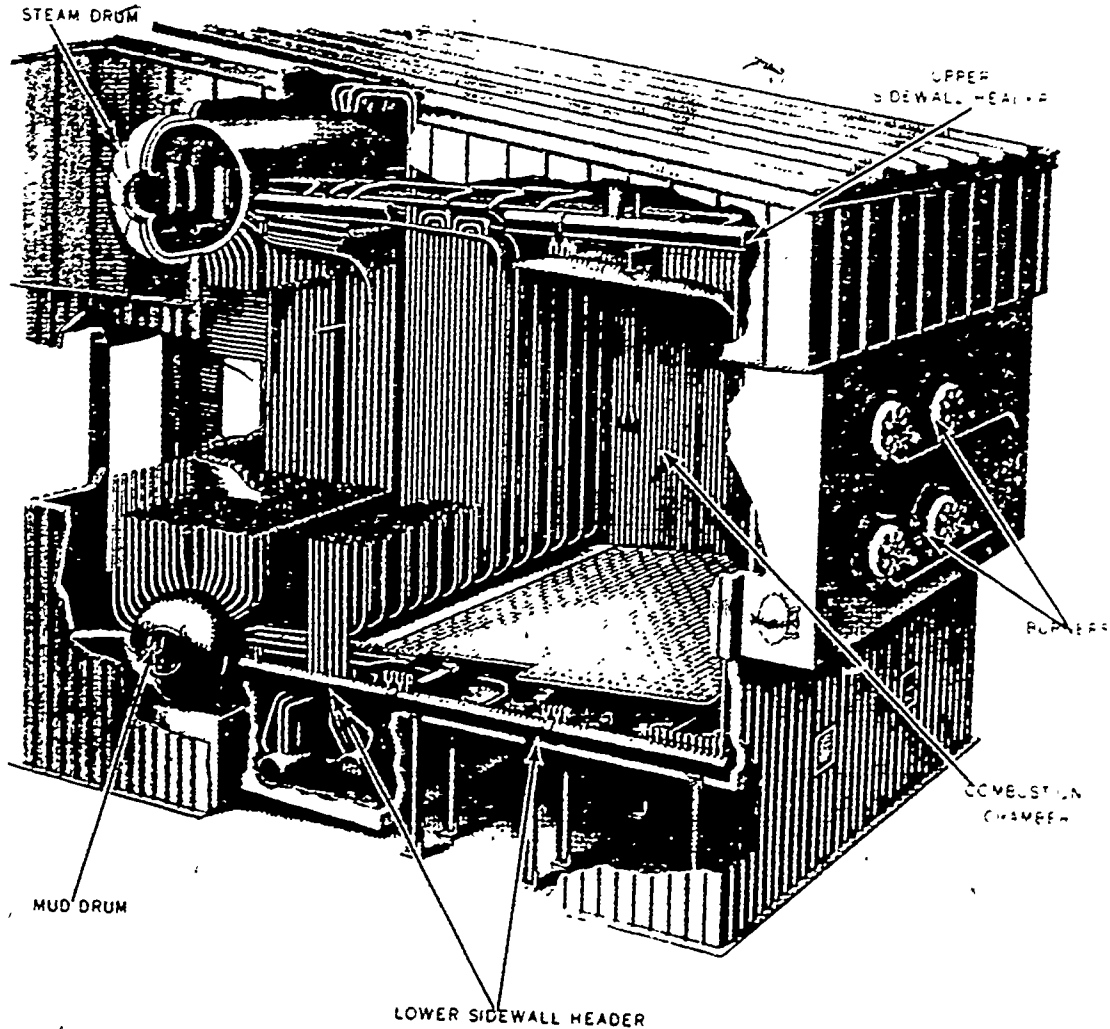


Figure 2-15. An oil- and gas-fired integral furnace boiler.

factors must be considered—such as design and design characteristics. When a boiler is designed, you may be surprised to find that while the designer's approach is orderly and sound, he must look at his problem backwards. He starts with his desired results and works backwards to design and selects equipment to produce these results. He doesn't really spend his time in designing a device to produce steam; his approach is to develop a "gas cooler." A knowledge of this approach can prove valuable to anyone associated with the specifying, purchasing, evaluating, installing, operating, or maintaining of boilers, because it can help supply the basic reasons for design details and maintenance or operating procedures. You might say that in this discussion, we will examine the "how" and "why" of boiler design.

Types of Design. You probably realize by now that there are many different designs of water-tube boilers. Some of them were illustrated in the preceding discussion, but we believe that it will be worthwhile to give you a brief description of two.

Recovery unit. A typical recovery unit is shown in figure 2-14. It is used in pulp and papermills to burn back liquor, both to reclaim the heating value and to recover the chemicals for reuse.

Integral furnace unit. In figure 2-15, we see an oil-and gas-fired integral furnace boiler furnished with four combination burners. Except for the floor, the combustion chamber is surrounded by steam generating tubes. The steam capacities of this type boiler range to 600,000 pounds of steam per hour and higher.

Looking at these different types of boilers (and there are many more), one might logically come to the conclusion that there is no logic in boiler design. The only thing they seem to have in common is that they are all different. One might wonder whether the differences might not stem from the fact that they were designed by different people. This has little to do with these differences. Actually, all boilers have the same fundamental job to do, and they all apply the same physical laws in doing this job. The differences in design stem mainly from differences in characteristics of the input to the boiler (the fuel) or the output from the boiler (the steam).

Installing Boilers. It is very important that a boiler has a good foundation. The top surface of the foundation should be level to insure proper alignment of the boiler sections and, thus, eliminate undue strain on the boiler

castings. The furnace foundation should be poured separately from the finished floor. Too, it should be of sufficient width and depth to afford ample support for the boiler without any settling, and it should extend 2 inches above the finished floor. Assembly procedures vary in detail for various boilers. However, manufacturers furnish detailed procedures for the assembly of their boilers. Usually, the plans for the foundations can be procured from them. Specific instructions for installing steam boilers, based on design requirements, are furnished by the manufacturer and the building plans are furnished by the civil engineer.

Exercises (624):

1. State the primary factors that must be considered prior to installing a boiler.
2. What makes boiler design characteristics different?
3. The specific instructions for installing boilers are based on design requirements. Who furnishes the instructions and procedures for boiler installation?

625. Name the equipment involved when performing preoperational checks of steam heating systems and answer key questions about these inspections.

Preoperational Checks. Safety is a prime factor in the operation of any central heating plant. In order to provide safe operating conditions for personnel and equipment, a preoperational inspection checklist may be found in AFM 85-12, Volume 1, *Operation and Maintenance of Central Heating Plants and Distribution Systems*, in the section "Steam Plants: Operation." Use this checklist when a manufacturer's explicit instructions are not available. Before we discuss the operation of plant equipment, we describe preliminary inspections of some of the equipment that is most often found in a plant.

Air preheaters. Generally, inspections of a tubular air preheater correspond with those of the pressure vessel itself. In rotary regenerative air heater installations, additional



precautions are necessary. The lubricating oil system, water cooling system, and electrical circuits must be functioning properly. Inspect the rotor seal, seal clearances, and the travel of the cleaning device nozzle. With a handcrank, turn the rotor one complete revolution to determine if there is any interference with rotation. If there is no interference, we can run the rotor for about an hour at normal speed under cold running conditions. This will show us whether any adjustments are required. Since there is no further immediate need for this unit, shut it down.

Economizers. The preliminary inspection for economizer operation is generally the same as the preliminary for boiler inspection (discussed later in this lesson).

Superheaters. Visually determine that safety valve gags have been removed and that valves are properly set and are in good working order. Make sure that all superheater drain valves are wide open. Additional inspections are generally the same as those that are discussed for the boiler.

Soot blowers. Before you assume that the soot blowers will function properly, check the installation thoroughly. The most important features that you should check are the correct element alignment relative to boiler tubes and the distances of nozzles from the surfaces to be blown. Make sure that a 3/16-inch hole is drilled in the seat partition or disk of the drain valve. Rotate the units to determine if there is binding in the rotary elements and repair any defects that you find.

Firing systems. As we begin our discussion of firing systems, we must remember that there are many different configurations. Therefore, we discuss a generalized type and not a specific piece of equipment. Use the manufacturer's instructions in connection with inspecting equipment.

a. Oil burners. Inspections for oil burners are applicable to both steam atomizing and mechanical burners and are not complicated. The most important items of interest are clean oil strainers, piping systems free of leaks, oil temperature controls, and service valves. These items must be in top condition. A defective oil temperature control mechanism can present serious fuel-air ratio problems during normal operations.

b. Gas burners. The gas system must be free from air and water. Gas pressure at the burner must be correct. The installation must be free from leaks, and all components must be checked with manufacturer's standards.

Induced and forced draft fans. The air handling system should be clean, the rotation

of fans should be checked, and drives must be properly lubricated. Sufficient cooling water for bearings must be available, if required. Close the dampers down to approximately 20 percent of the full open position to reduce the starting load.

Combustion controls and meters. The many control systems in use prohibit establishing a detailed inspection procedure, even in AFM 85-12. Generally, the system must be free from leaks; and air, hydraulic, and electrical components must be in a safe operating condition. Controlled devices should be shutdown, bypassed, or controlled manually. Meter lines must be free from obstructions. Place meters in operation only after flow and pressure have been established in meter pipelines. You must understand the control system that you operate.

Feedwater heaters. Open and closed feedwater heaters must have relief valves properly set and in good operating condition. All valves used for isolating controls and gages must be open. Steam and water inlet valves and water outlet valves must be closed.

Centrifugal and rotary pumps. There are many pumps in use, but our discussion will be limited. Items of particular interest common to these pumps are proper lubrication, correct rotation, availability of sufficient coolant for bearings, and a leakfree piping installation. We must pay particular attention to shaft-driver alignment. Turn the pump several revolutions by hand to make sure that there is no binding. Close all suction and discharge valves.

Reciprocating steam pumps. Examine all pressure gages, thermometers, strainers, steam traps, and other accessories for serviceability. Make sure that rod packing is properly installed, that gland nuts are tightened according to the manufacturer's instructions or are just finger tight, and that suction and discharge valves are closed. Steam and exhaust lines must be active and drained of condensate up to pump valves. Steam traps should be in operation. In some plants, it may not be possible to operate steam-driven equipment until a head of steam is generated. Only experience can provide the ultimate knowledge of how a specific plant must be started.

Steam turbines. Generally, the inspection of steam turbines is the same as the inspection of reciprocating steam pumps described above. Particular attention should be given to the operation of the overspeed trip device and the bearing lubricating system. Instead of conventional packing and glands, your turbine may have special carbon rings. Follow the manufacturer's recommendations explicitly



383

when inspecting the rings. Rotate the shaft to determine if the turbine wheel rotates freely.

Boilers. Since the pressure vessel is the most important piece of equipment in a central plant, it should receive special attention. Before starting up a boiler, you should check carefully and make sure that all modifications, repairs, and cleanup are completed. Look into the pressure vessel internals and be certain that the surfaces are free from scale and oil and that all tools and foreign materials have been removed. After taking one last look to see that no one is in the pressure vessel, you are now ready to close the manholes and handholes. The gaskets should be new or in good condition. Use a graphite paste or other suitable paste to prevent gaskets from sticking to the metal. Install special gaskets or handhole plates in strict accordance with the manufacturer's recommendations. Make certain that a hydrostatic test of the boiler has been completed and approved by an authorized person.

Visually determine that the combustion chamber is free from soot accumulations and all tools, and insure that no personnel are inside. Then seal the combustion chamber with appropriate refractory materials and replace cover plates as directed by the boiler manufacturer. Personally inspect safety valves and make certain that valve gags have been removed and that valves have been set and are working properly. Never operate a boiler that is known to have defective safety valves.

Inspect water column blowdown lines and gage glasses to see that they are properly installed and connected. Gage glasses should be clearly visible from the operating floor and lamps, if provided, ready for operation. The drain valves on the water column must be closed. If your water column has valves between the column and the boiler, make sure that they are locked open. Check all boiler piping for leaks.

Exercises (625):

1. Why is the rotor of an air preheater turned with a handcrank during the preoperational inspection?
2. State the most important features that should be checked when inspecting the soot blowers.
3. Why are draft fan dampers closed to

approximately 20 percent of the full open position during the preoperational check?

4. Name the equipment involved when performing preoperational checks of steam heating systems.

626. Describe the procedures for lighting off a boiler and placing it in service, and answer key questions about these procedures.

All boilers have a number of valves that must be opened or closed before you can successfully start the unit. A brief checklist is in AFM 85-12, Volume 1. You may operate a plant that has more valves or fewer valves than this list contains. Give special attention to superheater valves, water column and gage glass valves, the pressure gage steam drum valve and petcock, and recirculating line valves on the economizer.

Centrifugal and Rotary Pumps. In many installations, the only way that you can fill the boiler is by the feedwater pump. An electrically driven centrifugal pump is usually installed along with a reciprocating steam pump or steam turbine pump. We confine our discussion to this electrically driven centrifugal pump. The starting of this pump is similar to the starting of a rotary pump. Be sure to remove all air from the pump casing. Open the vent valve of the pump to fill the pump with water. Normally, the feedwater pump operates with a static head pressure. Start the pump with the discharge valve closed to reduce the starting load on the drive. Make sure that the lantern rings have an ample water supply. Do not operate the pump for more than a few minutes with the discharge valve closed; if you do, overheating may occur.

A small number of installations have extremely complex feedwater systems that use a fluid drive transmission between the electric motor and the centrifugal pump. The drive unit starts under "no load" conditions. A constant differential pressure control is used to maintain the feedwater pressure at approximately 25 psig greater than the steam drum pressure. The differential control varies the speed of the pump through the transmission. The manufacturers of such installations usually provide detailed starting instructions that should be followed explicitly.

Filling the Boiler. We should now be able to fill the boiler. Fill it slowly with properly treated water at a temperature of 70° F. to 100° F. The temperature difference between the water and the pressure parts of the boiler should never be greater than 50° F.; otherwise, severe temperature stress can occur. Fill the boiler to just below the middle of the glass on the water column.

Induced and Forced Draft Fans. Now actuate the draft system. In a balanced draft system, always start the induced draft fan before starting the forced draft fan. Check for abnormal vibration and noise.

Air Preheater. If a regenerative air preheater is used, start the rotor. Open the draft dampers to provide an airflow rate of about one-fourth of the requirement for the maximum capacity of the unit. Purge the combustion chamber and setting of all combustible gases with this flow of air for at least 5 minutes; then shut down the draft fans.

Firing Methods. We are now ready to light off the boiler. Since there are many firing systems in general use, we will discuss only the major points necessary to start these systems.

Underfeed stokers. Operate the feed mechanism and supply coal to the furnace. If no power is available, the coal must be shoveled. Place enough coal to cover all tuyeres to a depth of about 6 inches. Spread the coal to a uniform thickness. Now add wood, shavings, or kindling on top of the bed of green coal. Purge the furnace for at least 5 minutes at one-fourth of maximum capacity. This clears the unit of any combustible gas accumulation that could ignite and explode when the fire is started. Light the kindling and regulate the draft to keep the fire burning. In some installations, the fire is started with live coals from another furnace.

Do not add more coal to the furnace until the fire burns evenly. When the coal is burning freely, operate the draft system and control the combustion rate by regulating the air flow through the fuel bed with the blast gate or damper. If the boiler heats too rapidly, operate the fans at low rating or stop them for a time. If no power is available to operate the fan and stoker, feed coal by hand and use natural draft until the steam pressure is sufficient to operate the auxiliary equipment. The best fuel bed is one that is just thick enough to burn freely over the length of the stoker when the correct amount of excess air is supplied.

Spreader stokers. Operate the spreader mechanism and spread coal evenly over the

grate to a depth of 1 to 2 inches. If no power is available, shovel the coal. Place wood shavings or kindling on top of the fuel bed. Start the induced draft fan or open stack damper. Purge the furnace for at least 5 minutes at one-fourth of the maximum capacity airflow rate. Light the kindling and regulate the furnace draft to from 0.05 to 0.10 inch of water (negative). In some installations, the fire may be started with live coals from another furnace. Start the cinder return fan and open the return ducts, if there are any.

When the coals burn freely, start the forced draft fan and regulate the airflow to the furnace with the blast gate or damper. Start the stoker spreaders at low speed. Regulate the coal and air supply to the stoker to the extent that is necessary to raise the boiler pressure at a safe rate. If a spreader stoker has an oscillating or traveling grate for continuous ash discharge, start the stoker drive slightly before the boiler goes on the line. If the boiler heats too rapidly, operate the fans at low ratings or stop them for a time. When no power is available to operate the fan and stoker, feed coal by hand and use natural draft until the steam pressure rises enough to operate the auxiliary equipment. The best fuel bed permits a uniform combustion rate over the entire active grate area with a minimum of excess air.

Chain and traveling grate stokers. These stokers are used mainly in large boiler installations. We discuss starting a fire for this type of stoker in slightly more detail than for a spreader stoker. First, raise the fuel gate about 5 inches for bituminous coal. Run the coal to cover the first two compartments. If no power is available, shovel the coal. Place wood shavings or kindling over the coal. Start the induced draft fan or open the stack damper. Purge the furnace for at least 5 minutes at one-fourth maximum capacity airflow. Light the kindling and regulate the furnace draft to about 0.10 inch of water (negative).

When the coals burn freely, start the forced draft fan and regulate the airflow to the furnace with the damper. Admit air to the coal-covered compartments in sufficient quantity for the fuel to burn briskly. Now we can start the stoker, keeping a speed low enough to hold ignition at the gate. This will permit a gradual lengthening of the fuel bed. Admit air to the additional compartments as required. The stoker may be alternately stopped and started to stabilize ignition.

When you are burning anthracite, you should modify the procedure slightly. You

should set the fuel gate to give a fuel bed that is about 3 1/2 inches thick, and you should run the coal to cover the grate back to and including the first full compartment under the nose of the reverse rear arch. Do not admit air on the front zone, because this would delay ignition. Use the highest air pressure in the zones under the rear arch and no air pressure on the rearmost zone. Maintain the following zone pressure distribution: start at zero in the highest needed pressure at about three-fourths the length of the stoker; then drop to zero at the last zone. The object is to obtain the greatest combustion rate under the rear arch so that burning particles will be lifted from the fuel bed at that point and thrown forward to aid ignition.

When the hopper is filled, it is important that coarse coal and fine coal be evenly distributed. A fuel bed composed of fine coal restricts air admission more than one composed of coarser fuels. Therefore, if coal sizes are segregated in the stoker hopper, an uneven fuel bed will result. The grate surface or arches may overheat at the points where the coarse fuel burns.

Pulverized coal burners. Start the induced draft fan or open the boiler uptake damper and start the forced draft fan. Purge the furnace for at least 5 minutes at one-fourth the rate required for maximum capacity of the unit. Adjust the furnace draft to about 0.30 inch (of) water (negative) with the secondary air vanes closed. An excessively high draft makes lighting the burners difficult; an excessively low draft provides less expansion room for the flames and they may issue through the observation doors.

Insert a gas or oil lighting torch. Light it, but do not admit coal to the pulverizer until you are sure that the ignition fuel is burning steadily. The pulverized coal must be ignited as it enters the furnace through the burner; otherwise, accumulations in the furnace can cause an explosion. Make sure that the torch flame is in the direct path of the coal and the air mixture that is to be discharged from the burner. Adjust the forced draft air to get the proper torch flame.

Start the pulverizer and admit coal. Adjust the primary air to produce a rich mixture (more coal and less air than are used in normal operation). Keep the lighting torch in the path of the flame until fire is assured. Operators should stand at one side of the fire door or peephole to light burners. If the flame goes out or if ignition occurs within the feeder, instantly clear the furnace of suspended material and thoroughly purge the furnace and setting for at least 5 minutes

before trying to relight it. If the fuel fails to ignite as it enters the furnace, an explosion may occur. Therefore, never permit the furnace to become filled with unburned coal in suspension. Make a second attempt to ignite the burner, taking all the necessary precautions. A richer mixture of coal and primary air may be needed.

After the burner is lit, gradually decrease the fuel rate until a normal mixture of coal and primary air is attained. Gradually open the secondary air vanes as required for good combustion. During the first few minutes of firing a cold furnace, only the volatile matter in the fuel is burned. Therefore, there will always be some smoke. Keep a rich mixture of coal and air in the furnace to maintain ignition. Adjust the furnace draft to about 0.10 inch of water (negative). You should never attempt to light a pulverized coal burner from a hot furnace. Always use an ignition torch. Never try to operate the burners below their minimum required output. If the output is below minimum, the air velocity is not sufficient to carry the coal, and flow in the burner line will cease. Minimum output varies with different installations. Minimum air velocity is about 3000 feet per minute in horizontal runs. If the lowest permissible burner output causes rapid heating of the boiler, fire intermittently. Operate the burners at minimum output and shut down until temperatures even out. Repeat intermittent operations, as necessary, until the boiler is put in service.

Steam atomizing oil burners. Now we discuss another firing system that burns fuel in suspension. As is true of any such system, you should insure that the furnace is thoroughly purged. Start the induced draft fan or open the boiler uptake damper, and then start the forced draft fan. Purge the furnace for at least 5 minutes at the rate of one-fourth of the maximum airflow. All burner oil valves must be closed. Place the oil heaters in service and circulate the oil through the oil header and back to the storage tank or pump suction line until it reaches the proper temperature. For heavy residual fuel oils, the temperature should generally be about 210° F. Heat the oil to the temperature that gives a viscosity of about 200 SSU (Saybolt Seconds Universal). Refer to the burner manufacturer's recommendations for oil temperature and viscosity. Drain the cold oil between the oil header and the burner, and install the burner gun.

Set the air register of the burner to be lighted for approximately one-fourth of normal flow. Open the registers of the other

burners. Set the furnace draft to about 0.3 inch of water (negative). Set the register air pressure at 0.2 to 0.5 inch of water pressure (positive). Since the preferable values vary for different installations, each value must be determined by experience. Some boilers maintain so much natural draft that operating the airflow system during light off causes serious lighting problems. This condition must also be determined by experience.

Warm the steam header and drain all condensate. Set the burner oil pressure to 20 psig and the steam header pressure to 40 psig. These values vary for different installations, but in general, steam pressure should be maintained about 20 psig higher than oil pressure. Refer to the burner manufacturer's recommendations. Insert a lighting torch to ignite the burners. Never attempt to light one burner from one that is already in service, or from a hot refractory. Open the steam valves to the burner; then open the burner oil valve and ignite the oil.

If the oil does not ignite within 10 seconds or if the burner flame blows out, close the burner oil valve immediately. Before attempting to relight, purge the furnace. After the burner is lighted, readjust the air, steam, and oil flows for correct flame shape and color. Sparklers (unburned particles) at the edge of the flame usually indicate poor air distribution, which is conducive to improper combustion. Use burner air registers to control flame shape but not air flow quantity. Total airflow should be controlled by dampers or fan speed. If the lowest permissible burner output causes excessively rapid heating of the boiler, fire intermittently. Operate the burner at minimum output and shut down until temperatures even out. Repeat intermittent operation, as necessary, until the boiler is placed in service.

Mechanical oil burners. Purge the furnace in the manner described for steam atomizing oil burners. You should generally light a mechanical burner in the same way that you light a steam atomizing burner. The major differences are oil temperature and oil pressure. Generally, the oil temperature is about 220° F., which corresponds to approximately 150 SSU, and the oil pressure is about 100 psig in the oil header. We must remember that different burners can require different temperatures and pressures. Refer to the manufacturer's recommendations covering your burner.

Gas burners. Here again we must purge the furnace in the manner described above. Make sure that all burner and pilot gas valves are closed. Set the air register of the burner to be

lighted for about one-fourth of normal airflow. Open the registers of the oil burners. Adjust the furnace draft to about 0.3 inch of water (negative) and set the register air pressure at 0.2 to 0.5 inch of water pressure (positive). The best values are determined from experience, since values vary for different installations.

Vent the gas burner supply header through the vent piping until the first burner is in operation. Open the vent valve just enough to allow good pressure and flow control by the pressure controllers and automatic valves. Set the pressure in the burner header and the pilot gas header at the correct values for the specific burners and pilots that are in use. Open the pilot gas valve and ignite the pilot gas with an electric ignitor or a regular torch. After the pilot burner is ignited, open the main gas valve and ignite the main burner gas with the pilot burner. Never attempt to light one burner from another burner in service or from a hot refractory.

If the main burner does not ignite within 10 seconds, or if the torch, pilot, or main burner flames blow out, close the burner and pilot gas valves immediately. Before attempting to relight, purge the furnace. After the burner is lighted, readjust the airflow and gasflow for correct flame shape, location, and color. The flame should be blue with a yellow tip. It should be stable and should not impinge on the burner tiles, burner parts, rear wall, side wall, or boiler tubes.

Placing Generating Unit in Service. Keep a firing rate that is sufficient to raise the boiler water from room temperature to the boiling point (212° F.) in about 90 minutes. If the unit is filled with warm water, the time can be reduced, but it should not be less than 45 minutes. From this point on, increase the temperature of the water at the rate of 100° per hour. In new boiler installations, check to see if expansion has caused any binding or interference. We must remember, however, that the manufacturer of your boiler may recommend a different rate of firing and temperature rise. Some boilers may require long periods during which the firing rate is to be gradually increased. This gradual increase decreases the possibility of damage to the setting as a result of thermal stress.

Insure that combustion is complete, particularly if you are using a fuel burned in suspension. Incomplete combustion can occur with a cold boiler and can create conditions in which a fuel explosion might take place. Some large installations use light oil to start a boiler; then, when the furnace temperature attains the proper level, normal fuel feed is

started. Many plant operators operate the combustion control system in the manual mode. They find that this method makes it easier to adjust the rate of fire and achieve the proper airflow.

Check the steam pressure gage to be sure that it is registering. When the steam drum reaches a pressure of approximately 15 psig, close the drum vent valves. Ease up on the stem of the main steam stop valve to prevent serious expansion stress. If there is no steam on either side of the valve, lift the valve slightly and gently reseal it to make sure that it is not stuck. Open the drain valve on the boiler side of the main stop valve. Maintain a normal water level by blowing down or feeding water, as required. Be sure that the water level is not too high, especially if a superheater is used, since water may be carried into its elements. Check for leaking gasket joints. If a gasket is leaking, shut down the boiler, drop the pressure, and tighten the joint. If the gasket continues to leak, replace it and repeat the starting sequence.

Superheater. Throttle the superheater outlet drain valve, if necessary, to maintain the approved rate of steam pressure rise during the start up. Do not close the valve completely; steam flow through the superheater is necessary to prevent overheating the tubes. When the drain valve from the superheater inlet header starts discharging steam, throttle the valve to approximately one-quarter-turn open. (For boiler operating pressures below 200 psig, close the valve completely.) When the pressure reaches 200 psig, close the valve.

Economizer. Keep the economizer recirculating valves open while you are raising pressure in the boiler. Before feeding water, open the vent on the economizer inlet header until the accumulated steam, if any, blows out.

Feedwater regulator. Approximately 15 minutes before the boiler begins to produce measured output, thoroughly blow down the thermostat tube of the regulator, if there is one installed. Blow down the system from both the water side and the steam side. Actuate the equalizing lines and allow the tube to attain a stabilized temperature.

Control system. Blow down all condensate and oil from the filters, moisture separators, and air tanks. Adjust the air pressure reducing valves to produce the correct instrument air supply pressure. Place the controllers in service, using the approved procedures for the specific installation. Adjust the controllers to obtain the correct pressures, drafts, levels, temperatures, flows, and combustion

efficiency as soon as operating conditions permit.

Boiler. Before placing a producing boiler on the line in either single or multiple operation, open all drain valves between the boiler and the main steam header, especially those between the two stop valves. Warm up the steam line between the main header and the boiler; use the bypass valve around the main valve or backfeed through the drip line. Raise the pressure in the steam line. When the line is hot and at header pressure, fully open the header stop valve. When the boiler pressure is within 10 to 15 psig of line pressure, open the bypass around the main steam stop valve; then slowly open the valve. As the boiler reaches line pressure and begins to steam, the nonreturn valve will slowly rise to the wide open position.

After the boiler is on the line and steaming, close all superheater drains, any drain valves not discharging condensate, and the bypass valve around the nonreturn valve. Close the economizer recirculating valve when adequate continuous feedwater flow is established. The drain at the nonreturn valve should be closed last. If steam is being raised on a boiler that is not connected to a header under pressure, raise the pressure on the entire steam line at the same time. During this operation, leave all drip lines open on the header system. Maintain a firing rate that will eliminate excessive temperature differences between the top and bottom of the drum. These stresses can damage thick steam drums.

Steam Turbines. Now that you have a producing boiler, you can start the steam-turbine-driven auxiliaries if you wish. Make sure that the turbine case drain valves are open. Slowly crack the exhaust valve to permit any condensed steam to drain. When the turbine case is hot, slowly open the main steam valve and bring the turbine up to normal speed. The manufacturer's instructions or individual plant characteristics may prevent the use of steam-driven equipment until after the open feedwater heater is in normal operation.

Reciprocating Steam Pump. Open the suction and discharge pump valves, any cushioning valves that are present, steam exhaust, valve chest, and steam cylinder drain valves. Crack open the steam inlet valve and slowly warm up the chest and cylinder. Adjust the cylinder lubricator to feed the required amount of oil. When the pump is warm, open the steam inlet valve gradually and bring the pump to normal operating speed and discharge pressure. If operation of



the steam pressure governor is satisfactory, open the steam inlet valve fully. Set the cushioning valves to obtain the correct stroke length and close the drain valves when they are discharging steam. Again, it may not be possible to operate steam equipment before the open feedwater heater is operational.

Open Feedwater Heater. Open the valve in the air vent line (or in the vent condenser, if one is present). Gradually open the feedwater inlet valve and fill the water storage compartment of the heater. Check the operation of the overflow device by leaving the feedwater inlet valve open until the water storage compartment of the heater overflows. Close the water inlet valve, drain the heater, and close the drain valve. Gradually open the water inlet valve and slowly increase the flow from 50 to 60 percent of the design rate. Slowly open the steam inlet valve. Check the steam pressure gage in the heater and make sure that positive steam pressure is maintained.

Slowly open the condensate return lines and trap discharge lines connected to the heater and allow the unit to fill to the normal operating level. As the water approaches the operating level, completely open both the steam inlet valve and the water inlet valve. Let the makeup regulating valve take control. Check the operation of the inlet controllers, high-level controllers, and alarms, if any. Keep checking the water temperature until the unit comes to within 2° F. of steam temperature. When it does, the unit is ready for service and the water outlet valve may be opened. Throttle the vent valve so that there is always a short plume of steam discharging to the atmosphere.

Closed Feedwater Heater. Open the vent valves on the feedwater side of the heater. Open the water valves slowly and start feedwater circulation, and close the vent valves when all air has been expelled and water is flowing from the vents. Open the vent valves on the shell side, if present. Then open the steam valve slowly and admit steam to the heater. Warm up the unit slowly. Never admit steam to the shell if water is not circulating through the tubes. Place the drain regulator in operation and set it to maintain the correct condensate level. Horizontal heaters with subcooling sections often have startup vents on the shell. Keep these vents open until a discharge of condensate indicates that the subcooler is flooded. Actuating a feedwater heating system advances us to a point where we can establish a normal operating routine.

Exercises (626):

1. When starting a centrifugal pump, why is the discharge valve normally closed?
2. Why is a boiler setting purged for 5 minutes prior to lighting it off?
3. How much coal normally should cover the tuyeres in an underfeed stoker?
4. Describe the procedures for lighting off an underfeed stoker.
5. Specify how thick the fuel bed should be on a traveling grate stoker when firing with anthracite coal.
6. Describe how a pulverized coal burner should always be lighted.
7. Describe the lighting procedure if a main gas burner does not ignite within 10 seconds.
8. Describe the procedures for lighting off a boiler that has a gas burner.
9. Describe the procedures for placing the boiler in service.

2-2. Feedwater Units

If you attempted to inflate an automobile inner tube by lung power, you would find that you could not fully inflate the tube. This is true because the buildup of pressure in the tube would finally exceed the capacity and strength of your lungs in creating air pressure by simply blowing into the tube. In steam heating plants, you probably noticed that the



boilers operated at high pressures. Then you, no doubt, have wondered how water was fed into these boilers against those pressures. From your experience with the inner tube, you know that the water must be placed under greater pressure than the pressure existing inside the boiler before it can be forced into the boiler. For this reason, dependable and efficient systems are designed to feed water under pressure into boilers at frequent intervals as the steam is used. Feedwater systems vary from the simple type of waterman supply and gravity-return system to the complex pumping system used in a high-pressure multiple-boiler installation.

627. Explain how water can be admitted to the boiler and list the common feedwater regulators.

Feedwater Regulators. To keep a constant water level, regardless of load fluctuations, feedwater must be injected into the boiler at the same rate that steam is generated and drawn off. The water can be injected normally through a globe valve in the feed pipe to the boiler, or automatically with a feedwater regulator. When automatic, throttling-type, feedwater regulators are installed, they must have stop valves on the inlet and outlet sides, and a throttling bypass valve for manual operation. Boiler feedwater control systems may be classified as single-element, two-element, or three-element systems. In a single-element system, the boiler water level is the only control element. These systems are satisfactory for boilers with relatively steady loads, as in central heating plants. The control elements in a two-element system are the boiler water level and the

steam flow. In a three-element system, the control elements are boiler water level, steam flow, and water flow. Two- and three-element systems are used with boilers that have frequent, sudden load changes and relatively small water storage capacity, such as those in large, power-generating stations. Three commonly used feedwater regulators of the single-element system are the float and lever or positive displacement type, the thermohydraulic or vapor generator type, and the thermostatic or metal expansion type.

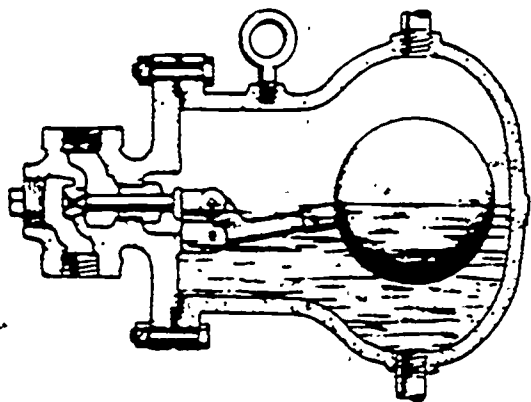


Figure 2-16 Positive displacement feedwater regulator.

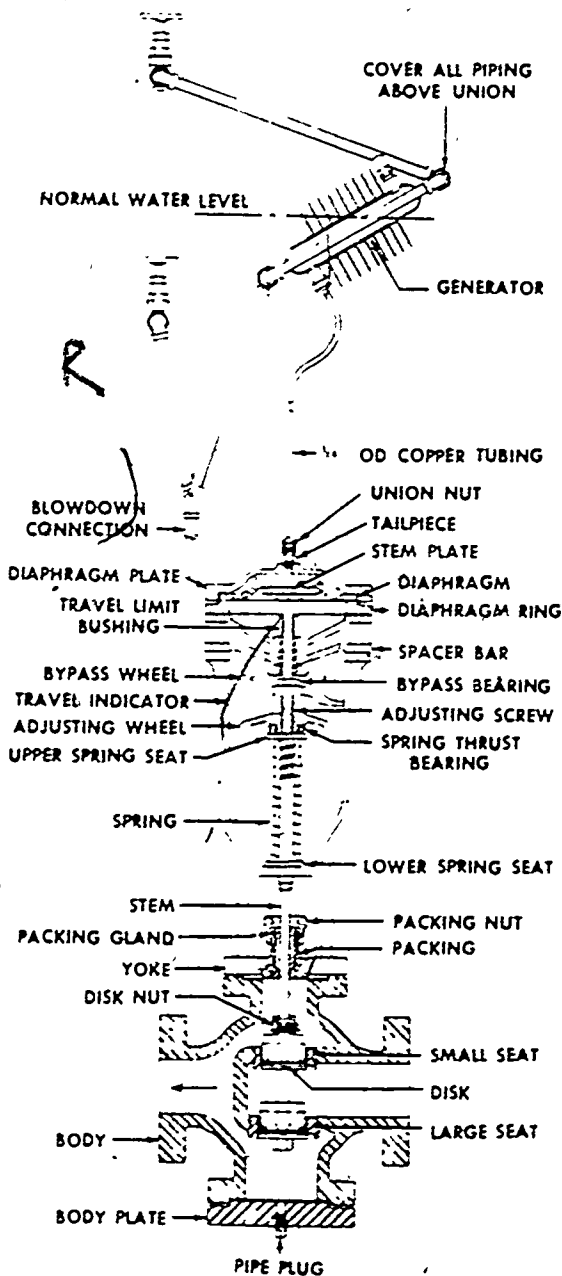


Figure 2-17. A vapor generator feedwater regulator.

Exercises (627):

1. How can water be admitted to the boiler?

2. List the common feedwater regulators that are used to control water flow to the boiler.

628. Explain the operational process of feedwater regulators.

Positive Displacement Regulator. In a positive displacement feedwater regulator, the float chamber is connected to the boiler drum or water column so that its mean water level corresponds with that of the boiler. The feed valve is of the balanced type and there are no stuffing boxes to leak or cause binding. In operation, the float follows the water level,

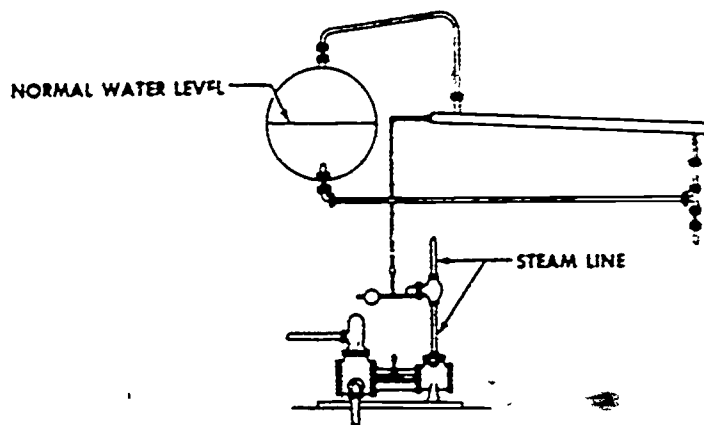
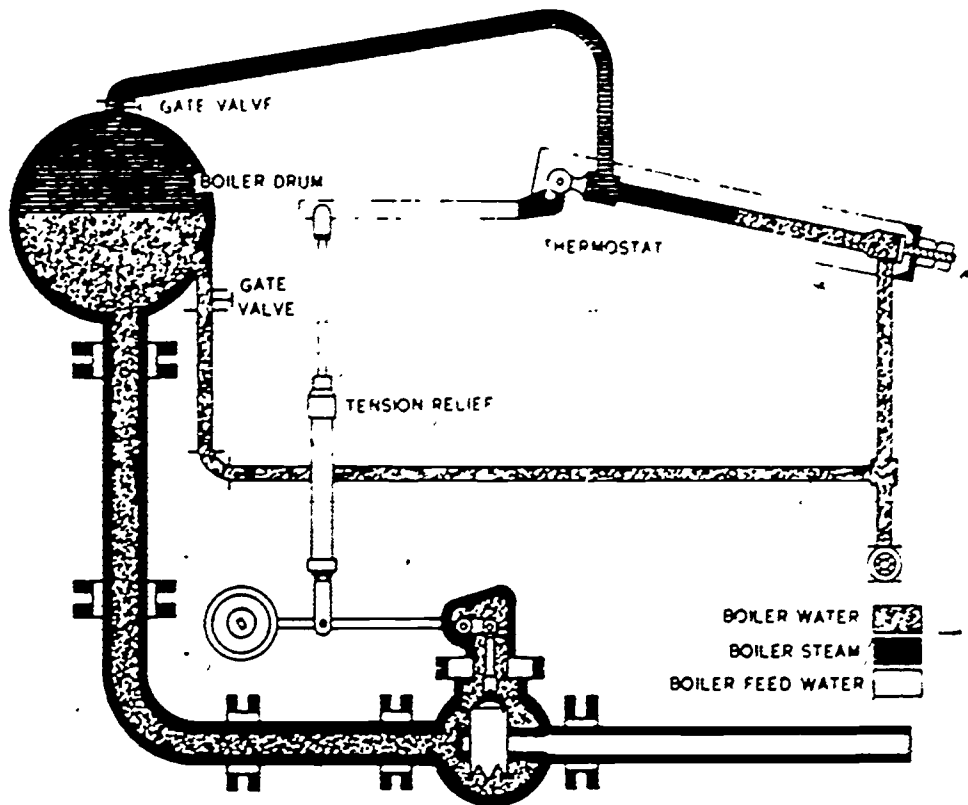


Figure 2-18. A schematic diagram of a thermostatic feedwater regulator.

opening the valve through a suitable system of levers to increase the water level and closing it to decrease the level. The valve and linkage provide a gradual and continuous flow of water from low to high water level. A small amount of alcohol introduced into the float vaporizes with the heat and builds up sufficient pressure to counteract the boiler pressure on the outside of the float and thereby prevents the float from collapsing (see fig. 2-16).

Vapor Generator Regulator. Figure 2-17 shows a thermohydraulic or vapor generator feedwater regulator. The operation of this equipment is based on the fact that steam occupies a greater volume than the water from which it is formed. The regulator consists of a generator, a diaphragm-operated valve, and connecting pipe and tubing. The generator is composed of an inner tube surrounded by an outer tube. The inner tube is connected to the boiler drum or water column and inclined to keep normal water level slightly above the center of the tube. The outer tube is connected to the diaphragm housing through metal tubing to form a closed system. Before the generator is started, the regulator valve should be closed and the generator inner tube should be drained and shut off from the water and the steam of the boiler.

The generator closed system (outer tube, tubing, and diaphragm housing) is then filled with hot water. When the generator is operating, with the inner tube open to the boiler drum, the water level in the tube corresponds to boiler water level. The heat from the steam in the upper portion of the inner tube raises the temperature of the water surrounding that part of the tube and converts part of it into steam.

This steam pushes the water from the outer tube, through the tubing, and into the diaphragm housing. The pressure, acting on the diaphragm, opens the valve against the spring force, and feeds into the boiler. The water in the generator inner tube rises with the boiler water level and condenses some of the steam. This reduces heat transfer to the outer tube and lowers the pressure in the tube. As pressure is reduced, the spring forces the diaphragm up, water is pushed into the generator, and the valve closes. Fins installed in the generator outer tube radiate some of the heat and prevent excessive pressures in the closed circuit. In some regulators, bellows instead of diaphragms operate the valve.

Metal Expansion Regulator. Figure 2-18 illustrates a schematic diagram of a thermostatic or metal expansion feedwater

regulator. Its operation is based on the expansion and contraction of an inclined metal tube (the thermostat) with corresponding changes in temperature. The expansion tube or thermostat is mounted on a steel frame so that the tube is always in tension. The ends of the tube are connected to the steam and water spaces of the boiler drum. A system of levers, which connect one end to a balanced valve in the feedline, operates the valve as the water level changes.

When the boiler water level reaches the lowest permissible point, steam flows into the tube and expands it to maximum length. At this point, tube and valve opening reach maximum expansion. When the water level in the boiler rises, a corresponding rise takes place in the tube. The tube begins to shorten, the valve closes, and the feedwater rate is reduced. The lower portion of figure 2-18 illustrates an alternate method of water regulation. Here, the steam inlet to a reciprocating steam boiler feed pump is regulated, changing the water delivered by the pump accordingly.

Exercises (628):

1. Why does the outside tube of the thermohydraulic regulator have fins on it?
2. Explain the operational process of the thermohydraulic regulator.

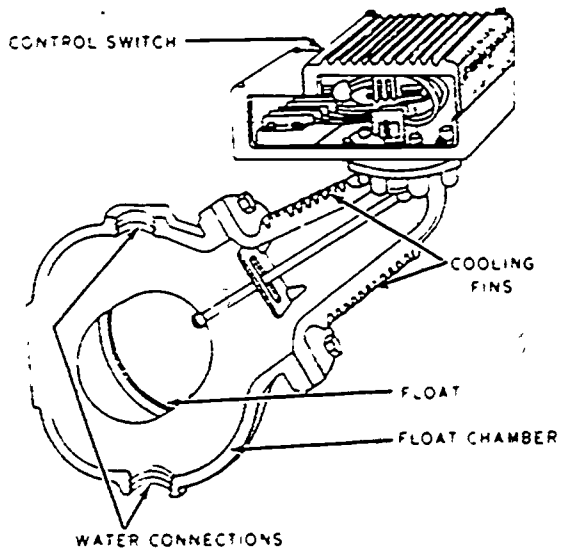


Figure 2-19 A typical boiler feedwater controller

3. Explain the process of operation of the metal expansion regulator when the water level in the boiler drops.

manufacturer's specifications. Use the regulator valve only to regulate flow, not to stop it. Close the hand-operated valves when the boiler is not in service.

629. Describe the process of maintaining proper water level in the boiler.

Exercises (630):

1. Identify the personnel who can repair, calibrate, or adjust feedwater regulators.

Learning Objectives 627 and 628 discussed various types of feedwater regulators used to control the level of water in the boiler. In addition to the regulators discussed previously, there is a feedwater control unit. The boiler feedwater control unit, shown in figure 2-19, is provided to maintain a fixed water level and thereby protect the boiler from feedwater failure. This unit consists basically of an enclosed float-actuated valve, an electrical switch, or a combination of both, mounted on the outside of the boiler near the water-sight gage. The feedwater control unit adds water to a boiler by opening a water valve or operating a water pump. It eliminates a high water line by actuating an overflow valve. The control provides for ringing a bell when the water in the boiler becomes dangerously high or low. The unit also stops the operation of a stoker, oil, or gas burner when the water line is low.

2. Who provides the procedures for adjusting feedwater regulators?

2-3. Pumps

Pumps are used to move liquids from one point to another. They perform many functions in steamplant operation. For example, they are used to feed water to the boiler, transfer condensate, or pump fuel oil.

Exercises (629):

1. What is used to maintain a fixed water level to protect the boiler from feedwater failure?

631. Identify the types of pumps used and specify the main operating principles of the pumps.

2. Describe the process of maintaining proper water level in the boiler when using a feedwater control unit.

Operation of feedwater and fuel systems depends on some means of moving the liquid through the system. The main types of pumps that accomplish this are the centrifugal, reciprocating, and the rotary. The following paragraphs discuss design characteristics and operating principles for each type of pump.

630. Identify the personnel authorized to adjust feedwater units in heating systems.

Centrifugal Pumps. In this type of pump, a rotating impeller or runner gives velocity to the fluid, and centrifugal force pushes it from the impeller. These pumps are compact, discharge at a uniform rate of flow and pressure, contain no valves or pistons, and can handle a variety of fluids according to their design. The number of impellers determines whether a centrifugal pump is of single-stage or multistage design. A single-stage pump has only one impeller. A two-stage pump has two; the first discharges into the suction of the second. Multistage pumps are used in high pressure operation. An impeller is either single or double suction. In the double-suction type, water enters the eye of the impeller from both sides.

Operators will report any malfunctioning of the feedwater regulators to their supervisors. Only authorized personnel should repair, calibrate, or adjust system components. If necessary, operate on manual control or hand operate the bypass valve. Authorized personnel will adjust feedwater regulators in strict compliance with published

Single-stage double-suction centrifugal pump. The main parts are a rotating element called the impeller or runner, the casing, the shaft, and the bearings that support the shaft. The impeller admits the water through the center (eye) and discharges it through the



outer rim. The casing contains the inlet and outlet passages for the water. It guides the water from the inlet connection into the impeller and away from the impeller to the discharge connection. The shaft supports and drives the impeller and is, in turn, supported by the bearings. In addition to the essential parts that we have mentioned, shaft sleeves, stuffing boxes, and wearing rings are also usually used in centrifugal pumps.

Shaft sleeves. Shaft sleeves protect the shaft from the corrosive or abrasive effects of the pumped liquid. Sleeves are held in place by two nuts.

Stuffing boxes. Stuffing boxes, located where the shaft passes through the casing, prevent liquid leakage from, and air leakage into, the pump. A stuffing box consists of a casing, ring of packing, and a gland at the outside end. Each stuffing box usually has a seal cage with a connection to supply sealing water under pressure. The sealing water blocks out air and lubricates and cools the packing and shaft sleeve.

Wearing rings. Wearing rings reduce leakage from the discharge to the inlet side of the impeller. These rings should be replaced when the clearance is more than 0.003 inch per inch of wearing ring diameter.

Operation. In operation, the impeller moves at a relatively high speed, giving energy to the liquid and forcing it outward. This creates a lower pressure at the impeller eye, which draws additional water. The casing converts the velocity of the water leaving the impeller into pressure by gradually increasing the cross-sectional area of the passage. The output can be controlled by regulating the speed, recirculating part of the water from the discharge to the suction, or throttling the discharge.

Reciprocating Pumps. Reciprocating pumps are positive displacement units that impart pressure to the liquid by means of a piston or plunger with reciprocating or back-and-forth motion. All reciprocating pumps consist of two principal parts: a pump or liquid end, in which pressure is imparted to the liquid; and a drive end, through which motion is applied to the piston or plunger in the pump end. Reciprocating pumps may be single-acting or double-acting. A single-acting pump discharges only once per cycle (each double stroke); a double-acting pump discharges twice.

A horizontal duplex-piston steam pump has two steam pistons and two liquid pistons, all of which are double-acting. A duplex pump is, therefore, equal to two simplex pumps lying side by side. The piston rod of one pump

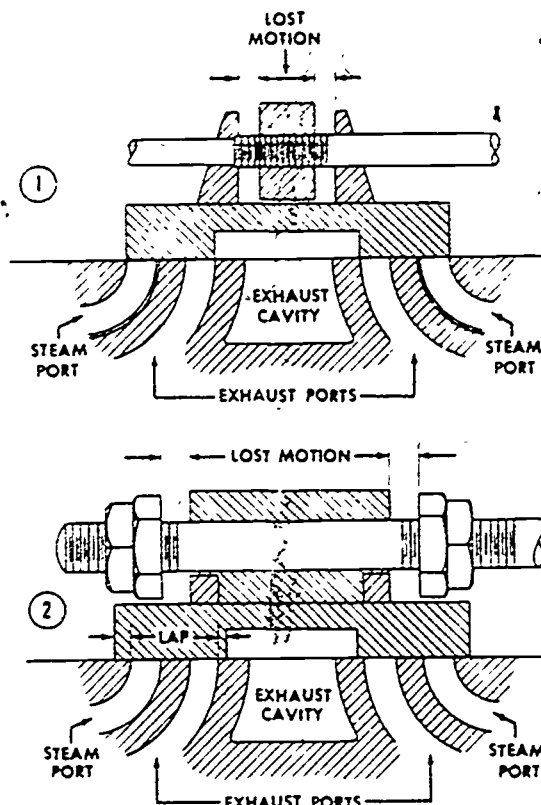


Figure 2-20. Two methods of providing lost motion in a duplex pump slide valve.

operates the steam valve of the other through a system of bellcranks, rocker arms, or links. Since the stroke of one piston begins before the other piston comes completely to rest, the water discharge is almost continuous.

Steam end. Each end of a steam cylinder has two steam ports, as shown in figure 2-20. One of these ports admits steam; the other discharges it. The steam trapped in the cylinder when the exhaust stroke nears completion acts as a cushion to prevent the steam piston from striking the cylinder heads. Some pumps have small hand-operated valves on the side of the steam chest. These valves regulate the amount of cushioning by controlling the escape of the steam trapped in the cylinder. Maximum cushioning is obtained with the valves closed.

Lost motion. Lost motion is introduced in the valve gear to keep one piston in motion when the other is reversing at the end of its stroke. Figure 2-20 shows two methods of providing lost motion in a duplex pump slide valve. The valves are not fastened rigidly to the stem. This permits the piston to move during a portion of its stroke without moving

the steam valve. By adjusting the lost motion, the length of the stroke can be determined.

Seals and drains. Piston rings on the steam piston prevent leakage from one side to the other. A stuffing box, with packing and gland, seals the steam from the cylinder around the piston rod. Petcocks at each end of the steam cylinder drain condensate.

Lubrication. The steam end of the pump requires regular lubrication. Cylinder oil is sometimes introduced into the steam line or steam chest by means of a lubricator.

Output control. Pump output is controlled by regulating the speed of the strokes. This is done by either manual or automatic throttling of the steam supply.

Liquid end. Several types and arrangements of valves are available for the liquid end. Each valve is designed for a particular service. Leakage around the piston is prevented by metal rings or canvas. Some pumps are equipped with a cylinder liner that can be replaced when worn. Leakage of liquid along the piston rod is prevented by a stuffing box with packing and gland.

Rotary Pumps. Rotary pumps are positive displacement pumps. They discharge a definite quantity of liquid for each revolution of the shaft. They use rotating cams, screws, lobes, sliding vanes, or gears to impart pressure to the liquid. In an external-gear, power rotary pump, the moving parts consist of two gears which rotate in opposite directions with the teeth meshing. This creates a partial vacuum which causes the liquid to enter the pump. The liquid first fills the spaces between gear teeth as they separate on the suction side. Then, it is carried to the discharge opening in the pump and displaced by the meshing of the gears. The discharge is even and without pulsations.

Exercises (631):

1. Identify the types of pumps used.
2. What determines whether a centrifugal pump is of single-stage or multistage design?
3. Specify the operating principle of the centrifugal pump.
4. Name the two principal parts of a reciprocating pump.

5. Specify the principle of operation for a reciprocating pump.

6. Specify the operating principle of the rotary pump

632. State the factors used for selection of pumps and specify pump installation requirements.

Selection of Pumps. Several factors must be considered prior to installing a pump. Where noise or vibration generation must be kept at a minimum, it is essential that the pump be suited to the hydraulic characteristics of the system and be accurately selected in order to operate without cavitation. Vibration and unbalance become more critical as the speed of the pump increases. A low speed pump will operate quieter than a pump of the same head and capacity at higher speeds. The selection of the proper pump, speed, and motor combination is more effective in eliminating system noise than the installation of pipe insulators. Sleeve-bearing motors and pumps are generally restricted to a speed of 1750 rpm. Pumps for handling liquids of medium temperatures have special seals and bearing lubricants. High temperature pumps for liquids above 325° F. normally have special pump construction and materials. The bearings and seal areas are water-cooled.

Pump Installation. In all installations, the pump, the driver, and the controls must be readily accessible for regular maintenance and for repairs. Pump suction and discharge piping connections are not necessarily of the same size as the system leading to or from the pump. Changes in the system to fit the pump connections should be as close to the pump as possible. If a reducer is used in the suction piping, it should be tapered with the top flat to avoid an air pocket. Suction and discharge piping must be supported so that no strain is transmitted to the pump. Normally, the pumps are assembled at the factory and they come properly aligned. However, all base plates are flexible to some degree, and each pump, regardless of type, must be realigned after installation in accordance with the manufacturer's specifications. Alignment can be maintained when the base plate has been properly bolted to it. It is common practice for the manufacturers, to include a pumping

395

system trouble analysis guide for you to follow to install, maintain, and operate the various types of pumps.

Exercises (632):

1. State the factors used for selection of pumps to be installed.
2. Which pump operates quieter?
3. Specify pump installation requirements that are considered prior to installation of a pump.

633. Analyze and compare the maintenance requirements of the centrifugal, reciprocating, and rotary pumps.

Centrifugal Pump Maintenance. Never run a centrifugal pump dry, because liquid is necessary to lubricate the internal surfaces. Never throttle the pump suction to regulate the flow of water, because cavitation will result. Do not permit the pump to stand idle for long periods of time. It should be operated at least once a week. The following paragraphs discuss preventive maintenance inspection and pump maintenance requirements pertinent to centrifugal pumps.

Daily requirements. Each day, you should inspect the centrifugal pump for abnormal noise and vibration; abnormal pressure and flow conditions, excessive or inadequate packing leakage (water cooled bearing); hot bearings; and hot stuffing box.

Semiannual requirements. On a semiannual basis, you should check alignment of the pump and driver with the unit at a standstill and normal operating temperature, check shaft sleeves for scoring; replace packing, if required, drain the oil from oil-lubricated bearings, flush, and refill with clean oil; and check grease-lubricated bearings. Do not overgrease the bearings. When adding grease, remove the drain plug or use a safety fitting to prevent overgreasing.

Annual requirements. On a yearly basis, the pump is dismantled, a complete inspection is performed, and the following requirements are satisfied. Check the wearing ring clearances according to the manufacturer's

instructions; diametral clearance between 0.005 and 0.025 inch is usual. Examine bearings for wear, check clearances according to manufacturer's instructions, and overhaul, if necessary. Check shaft for scoring, corrosion, or wear at the seals, and also for proper alignment. Check impellers for corrosion, erosion, or excessive wear. Check and calibrate pressure gages, thermometers, and flowmeters. Inspect suction and discharge strainers.

Repair and replace defective parts found during the yearly inspection. Replace wearing rings when clearances are twice the original, or if the leakage appreciably reduces the capacity and head of the unit. Replace worn shaft sleeves or rebuild them by welding or metalizing. In the metalizing process, metal wire is drawn through a special gun to a nozzle where it is melted in an oxygen-gas flame. A blast of compressed air then sprays the molten metal onto the prepared surface where the particles mesh to form a coating. The air blast keeps the sprayed surface cool and prevents warping or distortion.

Reciprocating Pump Maintenance. Check as outlined under the centrifugal pump daily maintenance requirements covered previously. In addition, check for abnormal speed, improper stroke length, defective operation of lubricator, ineffective operation of governor, improper action of the air chamber, and steam and water leaks. To accomplish the monthly maintenance requirements, you repeat the daily inspection. Also, check for scoring of piston rods, binding of valve operating mechanism, lost motion adjustment, tilted glands in stuffing boxes, and a defective condition of strainers.

Annual maintenance requirements. Yearly, you should dismantle the pump, clean it, and inspect for the following:

a. Liquid end. Check the condition of the valves, springs, and retaining bolts; condition of cylinder liners; piston rings or packings; piston rod packing; relief valve, if used, and setting; alignment; and strainers, if used. Also, look for corrosion, erosion, or excessive wear of parts, and for transmission of strains from piping to pump. Another maintenance requirement is to calibrate instruments.

b. Steam end. Check condition of pistons and piston rings, slide valves, and seat; alignment; clearance between piston and cylinder liner; lubricator; and governor. Look for plugged steam passages in steamchest, scoring shoulders on cylinders, corrosion, erosion, and excessive wear of parts. Calibrate instruments and replace packings. Repair or

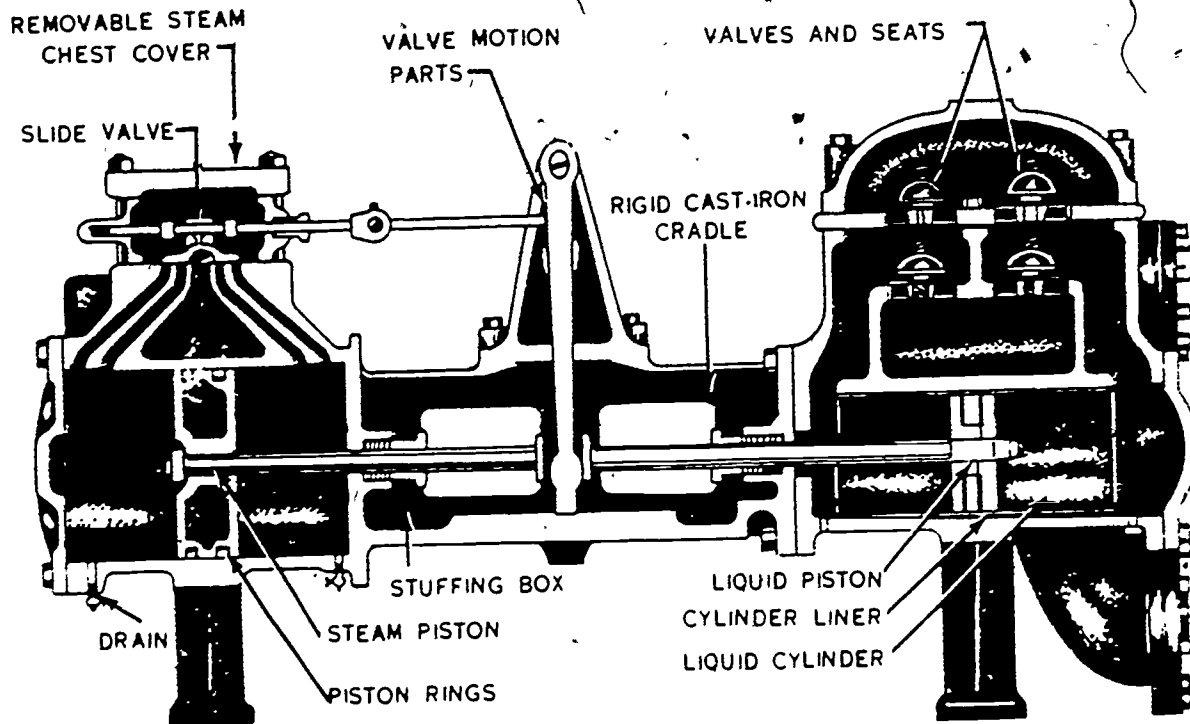


Figure 2-21. Horizontal duplex reciprocating steam pump.

replace all defective parts found during the annual inspection.

Stroke adjustment. Install a stroke indicator if one is not already present. The indicator may consist of a sheet metal pointer attached to the piston rod crosshead. Two marks are made on the pump frame. One mark lines up with the pointer when the pump is at one end of its full stroke; the other mark indicates the correct position at the opposite end of the stroke. In the absence of specific instructions for stroke adjustment, refer to figures 2-20 and 2-21 and use the following procedure:

- (1) Place piston rod at midstroke position.
- (2) Open valve (steam) chest cover.
- (3) Place slide valve at midposition.
- (4) Set and lock each adjustable collar at an equal distance from the tappet. (This lost motion spacing should be equal to one-half the width of the steam port opening.)
- (5) Start the pump. (If the stroke is too long, reduce the lost motion spacing; if it is too short, increase the spacing. Test with cushion valves wide open and pump operating at very low speed.)
- (6) On a pump slide valve designed like that in figure 2-20(1), lost motion can be adjusted by changing the block to one with a different thickness.

Rotary Pump Maintenance. The daily inspection and maintenance requirements for the rotary pump include checking for abnormal vibration and noise, abnormal pressure and flow conditions, excessive or inadequate packing leakage (water-cooled bearing), hot bearings and hot stuffing box. Discrepancies found during this daily inspection will dictate the maintenance requirements. A monthly inspection would include a repeat of the daily inspection. In addition, examine the external gear and bearing housings for correct lubricant level and condition.

Annual inspection. At least once a year dismantle the pump and inspect for excessive clearances, improper timing gear setting, corrosion, erosion, wear or other defects of parts, incorrect alignment (hot and cold), transmission of strains from piping to pump, defective gear teeth, improper operation and setting of relief valve (if used), defective suction and discharge valves, improper calibration of pressure gages, thermometers, and flowmeters, and defective strainers.

Maintenance requirements. Repair or replace all defective parts found during the yearly inspection. When installing new timing gears, be sure to follow the manufacturer's instructions for installation, adjustment, and

key slotting. When internal clearances increase above the permissible limits, the capability and efficiency of the pump decreases. Replace worn shaft sleeves or rebuild by metalizing.

requirements, for the centrifugal, reciprocating, and rotary pumps.

Exercises (633):

1. Why is it important *not* to let centrifugal pumps run dry?
2. What mode of operation should the unit be in when you check the alignment of a centrifugal pump and its driver?
3. Compare the daily maintenance requirements of the centrifugal and reciprocating pumps.
4. List the daily maintenance requirements for the rotary pump.
5. Compare the annual maintenance

2-4. Steamplant Operation

A central boiler plant is an assembly of coordinated equipment used to supply the heat needed to meet job load requirements. The steamplant will produce and supply the required heat only with coordinated operation of equipment.

634. Identify the types of gages used to observe steam pressure.

Indicating-Type Pressure Gage. Every boiler must be equipped with a steam pressure gage connected to the steam space of the boiler. The Bourdon-type, illustrated in figure 2-22, is the main type of pressure gage used to observe the steam pressure. Its measuring element is a tube of flattened cross section bent into an arc. One end of the tube is closed; the other is connected to the pressure source. When the pressure in the tube increases, it tends to become circular in cross

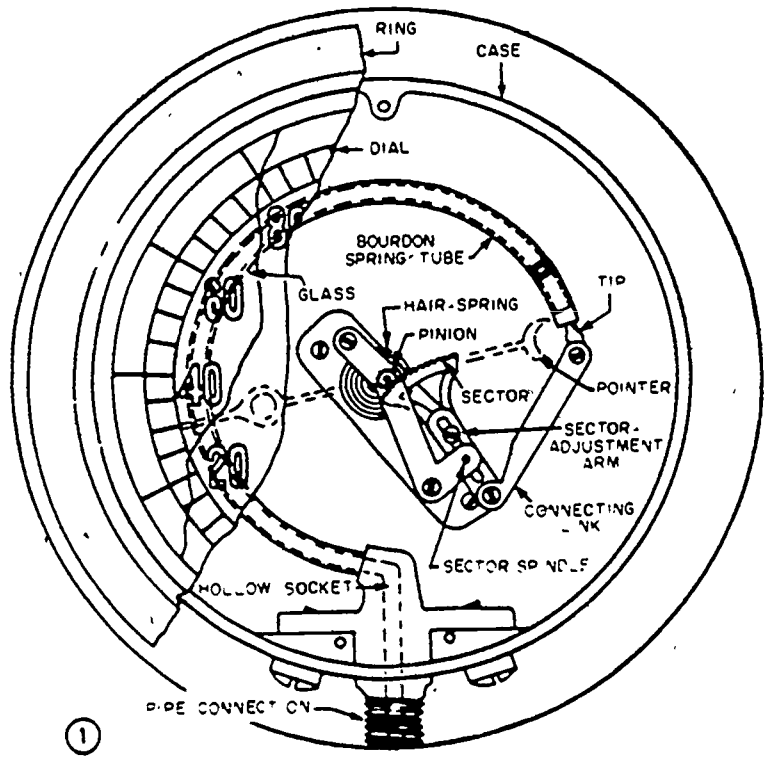


Figure 2-22. Bourdon-type steam gage.

section and, as a result, the tube straightens somewhat. The reverse occurs when the pressure is reduced. The free end of the tube is connected through a gear sector and pinion to a pointer moving on a calibrated dial. Bourdon gages should never be connected directly to steam or subjected to high temperatures. A water leg or a proper gage siphon to condense the steam should be used. Pressure snubbers, which protect the gage from damage to the mechanism or pointer by cushioning shock and pulsation, are sometimes used. These fittings, installed at the gage connection, contain a porous metal disc which dampens out pressure fluctuations in the line. A gage cock must be installed next to the gage and provision for testing should be made by installing a test gage connection.

Recording-Type Pressure Gage. Pressure recorders generally use a tube of oval cross section wound in a helical coil. The free end of the coil is connected to the pen arm (directly or through linkage and levers); the other end is connected to the pressure source. The operating principle is the same as for the

Bourdon tube. The chart upon which the pen records is driven by clockwork or a synchronous electric motor.

Exercises (634):

1. Which type of pressure gage is the main type used for observing steam pressure on a boiler?
2. Identify the types of gages used to observe steam pressure.

635. State the primary problem in maintaining steam pressure and list the control systems employed.

The primary problem of maintaining steam pressure is that of coordinating the steam pressure with fuel quantity, air for

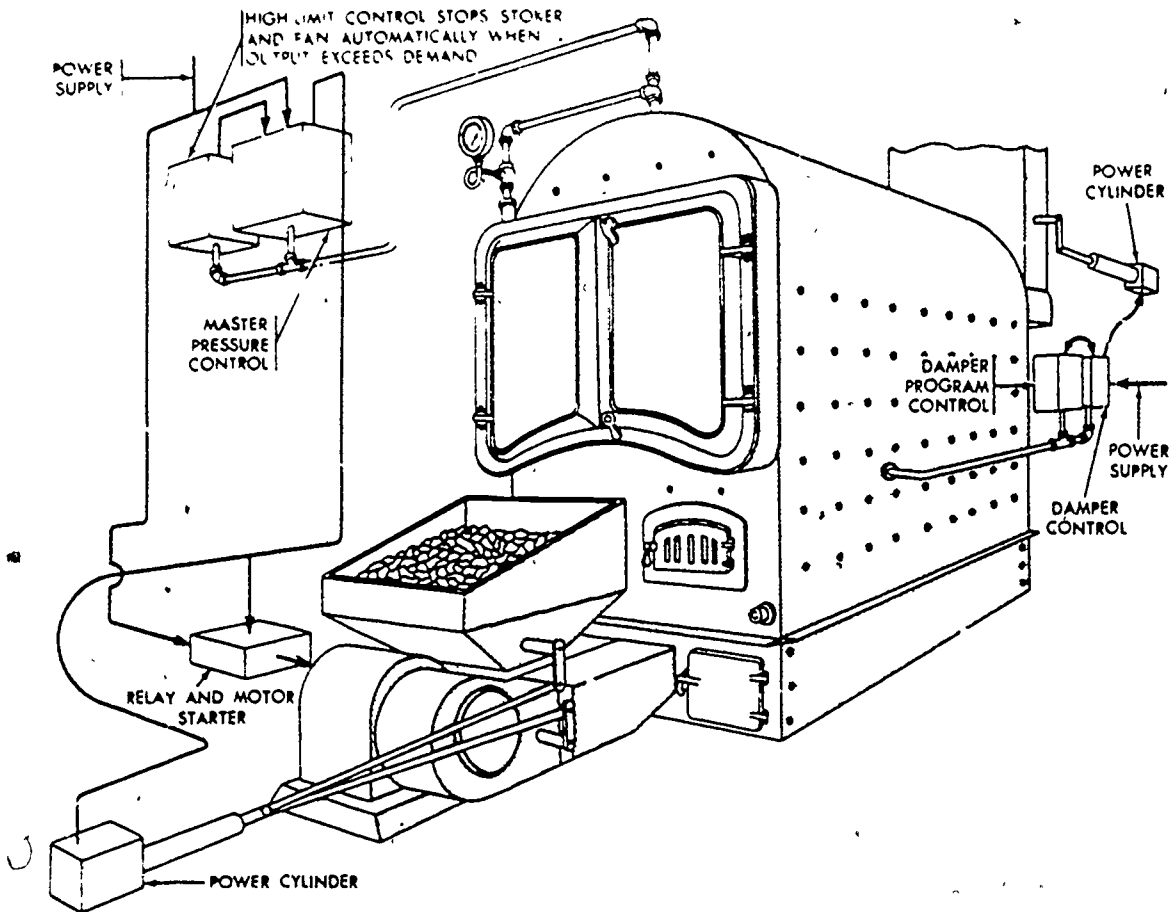


Figure 2-23. Pressure control system for small industrial boiler: high pressure limit cutout.

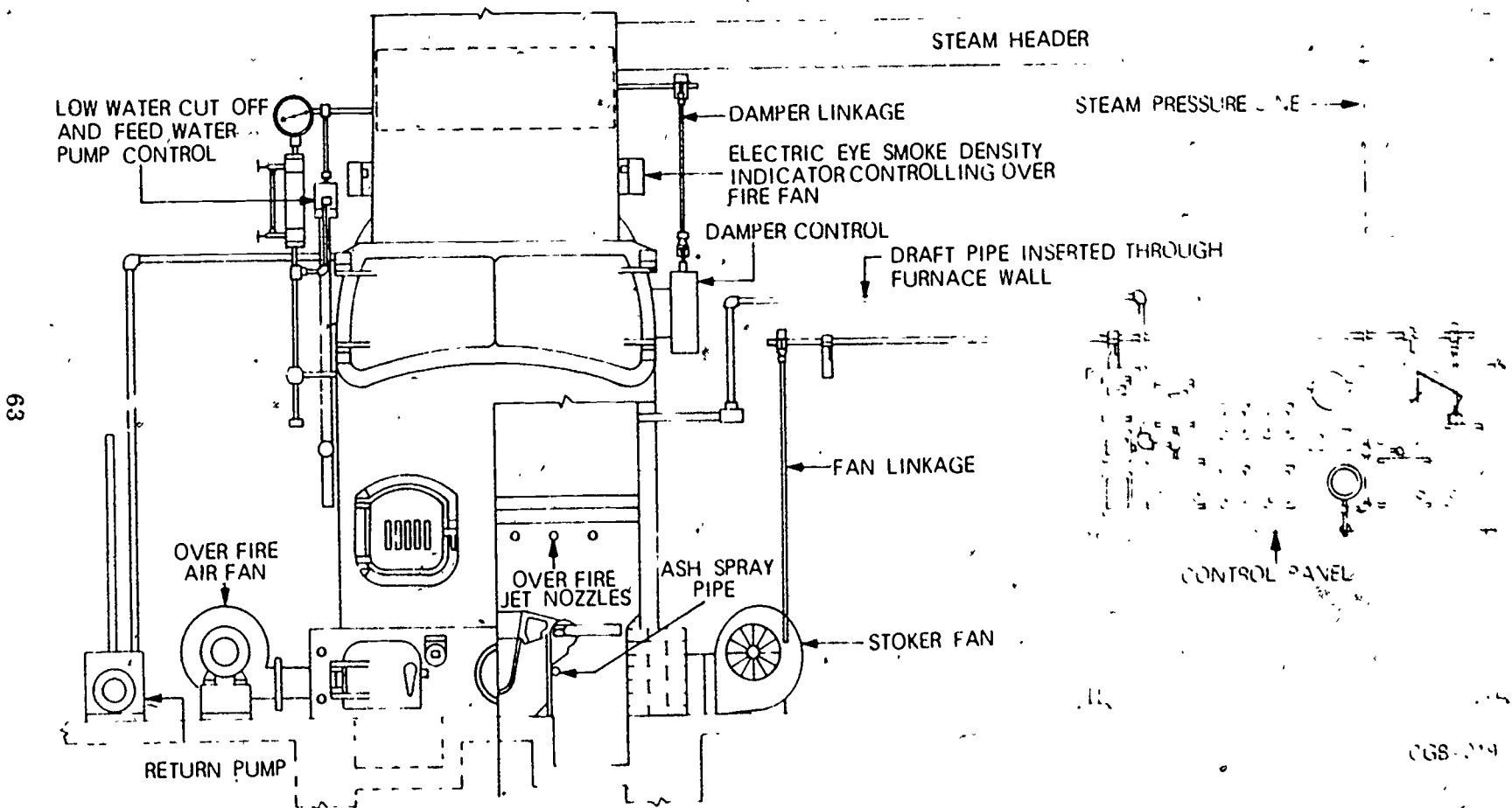


Figure 2-24. Pressure control system for industrial boiler, including smoke control.

combustion, removal of the products of combustion, and feedwater supply. There are three basic control systems used. All three of these systems are designed to respond to steam pressure demands to control the fuel and air for maximum combustion efficiency. Provisions are often made for automatic control, manual remote control, and hand control in cases of emergency. Pneumatic, hydraulic, and electric transmission media can be used. The three main control systems are the "on-off," the positioning, and the modulating or metering.

Exercises (635):

1. State the primary problem involved with maintaining steam pressure.
2. List the three basic control systems used to maintain steam pressure.

636. Explain how the control systems operate to control the steam output of a boiler.

"On-Off" Control System. This system is adapted primarily to small heating furnaces. Firing is done intermittently in cycles between predetermined high and low pressures or temperature limits of the end product delivered to the system (steam, hot water, or warm air).

Positioning Control System. Positioning controls maintain constant and predetermined fuel-air ratio and steam pressure, water, or air temperature, by positioning mechanical linkages which connect the damper-actuating devices and fuel feed apparatus. The fuel-air ratio, preadjusted for the best operating conditions expected, remains fixed. One type of positioning controls is the pressure control system shown in figure 2-23. The boiler steam pressure actuates a master pressure control to develop a loading pressure that is sent simultaneously to the fuel feed positioner and the air control. The furnace draft is independently controlled to maintain a predetermined constant draft, irrespective of

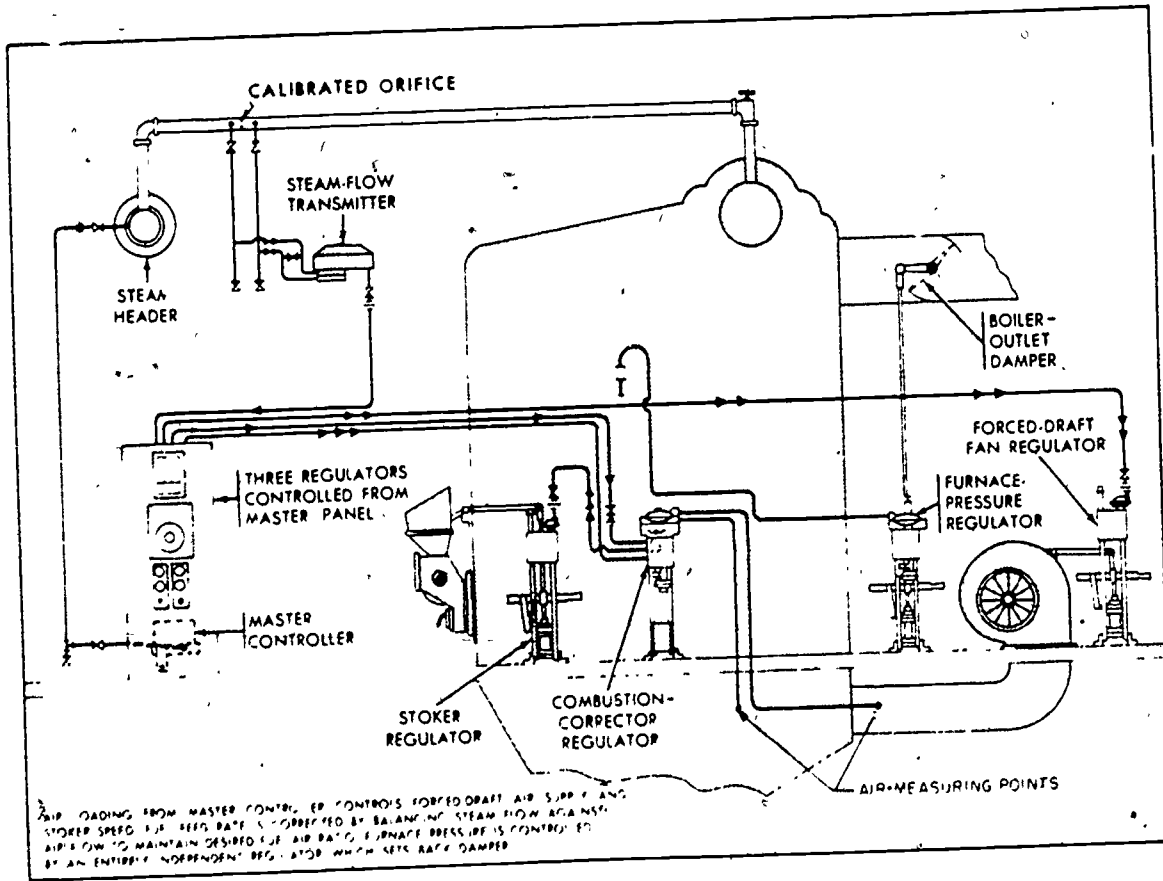


Figure 2-25. Metering-type combustion control for large boiler: direct airflow measurement.

load variations. Control is effected by a positioner which operates the boiler uptake damper to correct variations in furnace draft. When induced draft fans are provided, the same effect is obtained by operating the fan damper or changing the fan speed. When the system is operated, a decrease in steam pressure produces an increase in loading pressure, thereby increasing both the fuel feed and the airflow. The reverse is true if the steam pressure is increased. The system illustrated in figure 2-23 has a high pressure limit cutout. Figure 2-24 illustrates a system which includes smoke control.

Metering Control System. In metering control systems, the regulated characteristic (steam pressure, water temperature, air temperature) determines the firing rate, as described above. In addition, fuel and airflows are measured and adjusted to provide automatically the best ratio at all times. This is the system employed in large central boiler plants.

Airflow is determined by measuring the drop in air pressure across an orifice in the air duct or from windbox to furnace (see fig. 2-25). It can also be determined from the draft loss across any pass or combination of passes in the boiler, as illustrated in figure 2-26.

Fuel flow may be measured directly. However, in steam boiler installations, it is

generally considered as proportional to the steam flow. Steam flow is measured by the pressure drop through a calibrated orifice or by a venturi flow meter (see fig. 2-25).

Exercises (636):

1. Explain the principle of operation when using the "on-off" control system.
2. Explain how the positioning and the metering controls operate to control the steam output of a boiler.
3. Which control system would normally be used to control steam output of a large central boiler plant?

637. Specify the purpose of blowing down a boiler and water column, and list the types of valves used for blowdown.

Blowdown Valves. Blowdown or blowoff valves are used for discharging sludge and

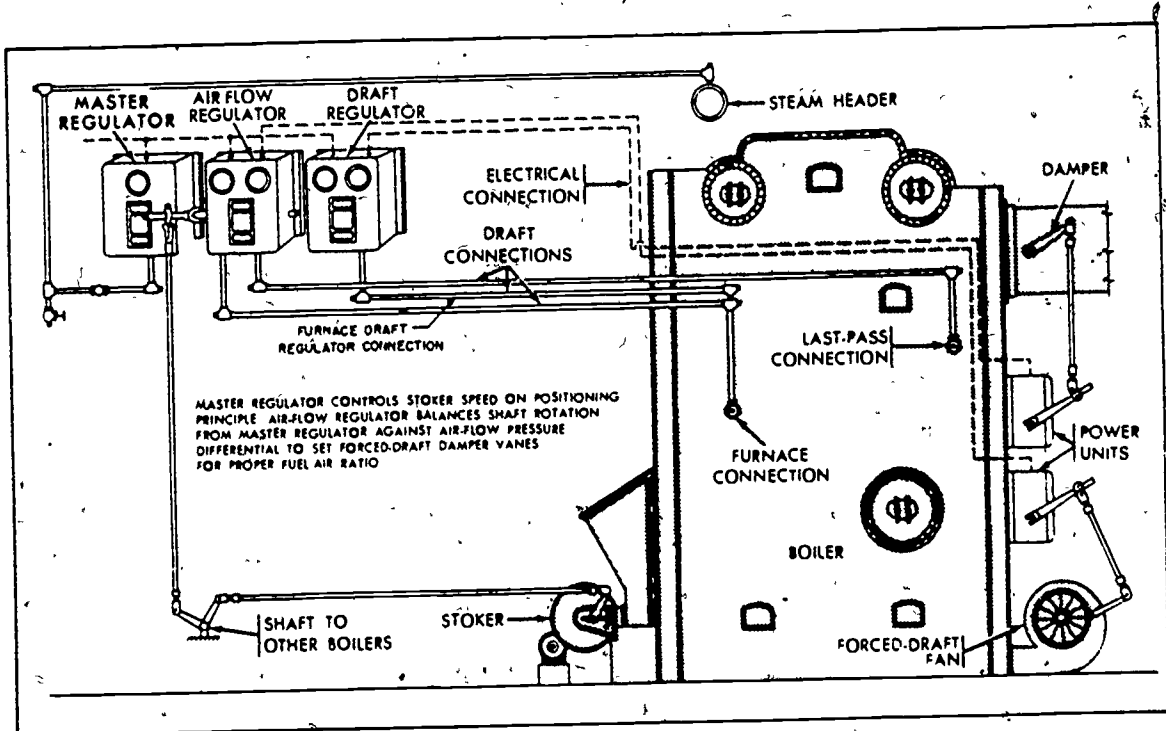
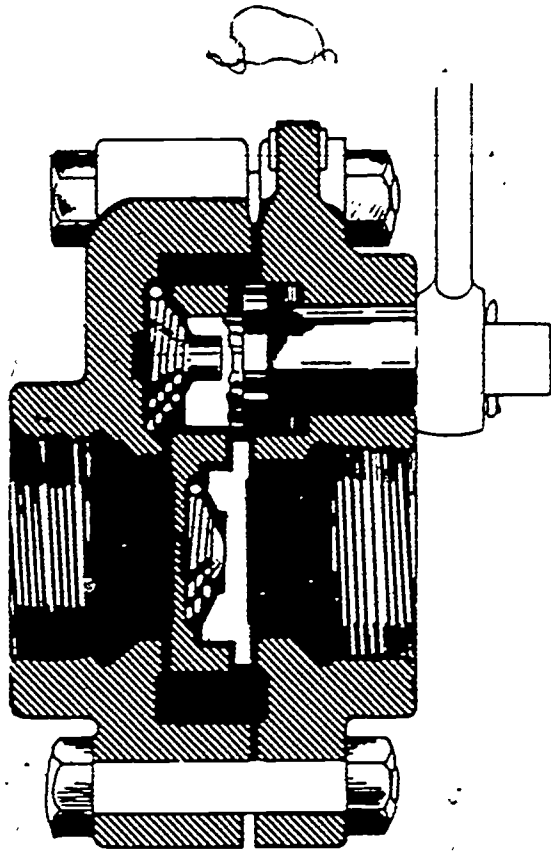


Figure 2-26. Metering-type combustion system with positioning control for fuel feed.



CKB-097

Figure 2-27. Swing-gate quick opening blowoff valve.

sediment from a boiler. They are also used to lower the water level rapidly and to reduce the total concentration of dissolved and suspended impurities in the boiler water. The blowdown connections are normally located at the lowest water space of the boiler, such as the bottoms of mud drums and headers. Since sediment tends to collect in the blowdown line where there is no normal water circulation, the pipe may become overheated and may burn out. Therefore, this line must be protected against direct furnace heat. A water column should be blown down once each shift, before placing a boiler on the line, and when in doubt as to the actual water level in the boiler. These blowdowns remove scale, dirt, or any solid matter that could plug the gage glass connection and cause a false water level indication.

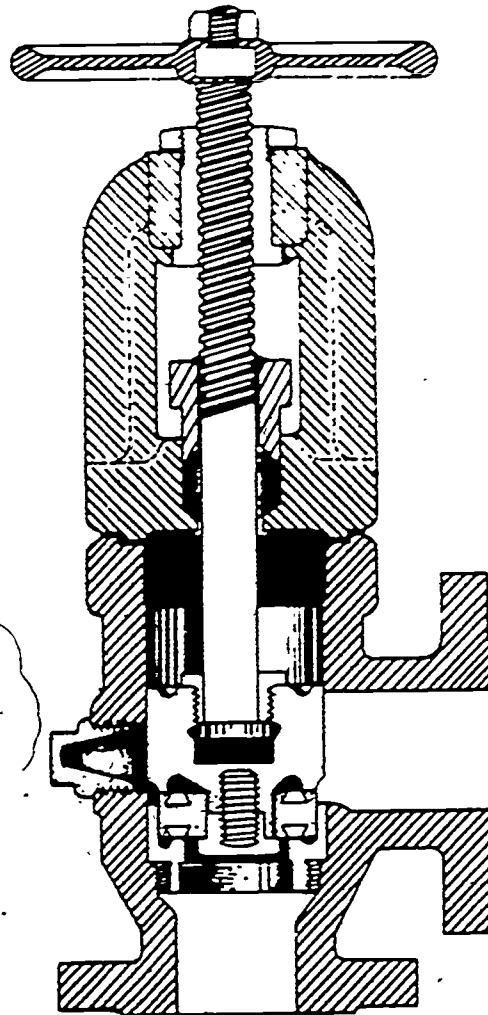
Sliding disc or swing-gate type. This type of valve, illustrated in figure 2-27, has a swing-gate or disc which moves between parallel faces so there is no wedging action and no possibility of jamming. A spring holds the disc in constant contact with the sealing surface around the port and its extension to keep grit from between the sealing faces. When operated, the disc rotates, preserving

and regrinding the sealing joint. These valves are usually quick opening.

Seat and disc or hard seat type. Figure 2-28 illustrates a seat and disc type of blowoff valve. The valve is usually installed with flow entering below the seat. These valves are normally slow opening. They require at least five complete turns of the operating mechanism to change from the fully open to the fully closed position and vice-versa.

Seatless type. The seatless blowdown valve is a slow opening valve in which a sliding plunger is the controlling element. When the valve is open, the plunger is raised and the blowdown discharges through ports in the lower portion of the plunger. When the valve is closed, the plunger is down and the discharge is sealed against the upper portion of the plunger which has no ports.

Valve Applications. According to the ASME Boiler and Pressure Vessel Code, a



CKB-098

Figure 2-28. Hard seat, slow opening blowoff valve.

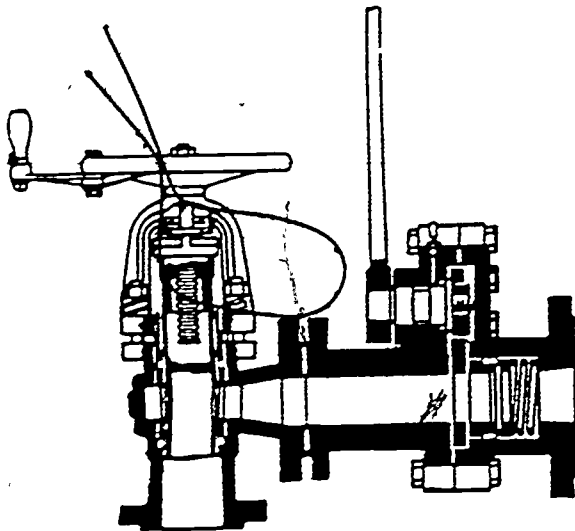


Figure 2-29. Tandem blowoff valve installation.

single, slow-opening valve can be used for pressures up to 100 psig. Two blowdown valves, in series, at each bottom blowoff pipe are required on all boilers for pressures above 100 psig. These may be two slow-opening valves, one slow-opening valve and one quick-opening valve, or one slow-opening valve and one plugcock. Where several blowoff lines from more than one boiler are connected to a common header, a guard valve is used to prevent workers from being scalded in boilers down for repairs. Blowoff valves and cocks are especially constructed to pass sludge and sediment. Valves with dams or pockets in which sediment can be trapped must not be used. Figure 2-29 illustrates a tandem installation consisting of a quick-opening, swing-gate blowoff valve connected in series with a seatless, slow-opening valve.

Exercises (637):

1. Specify the purpose for blowing down a boiler.
2. What is the purpose of blowing down a water column?
3. List the types of valves used for blowing down a boiler.

638. Specify how dissolved mineral matter enters the boiler and identify the methods of blowdown used with steam boilers.

When a boiler operates, the feed water continuously carries dissolved mineral matter into the boiler. However, the steam leaving the boiler carries away very little mineral matter with it. The concentration of dissolved solids in the boiler water therefore keeps building up. Many difficulties in boiler operation occur because excessive concentrations are allowed to build up. Therefore, when the concentration of solids has reached a certain point, some of the boiler water must be removed so that it can be replaced with feed water, thereby lowering the concentrations in the boiler. Sludge is removed at the same time. This process of removing water from a boiler is known as blowdown.

A blowdown line is generally installed somewhere near the bottom of the boiler as, for instance, on the mud drum; this is called the bottom blow. Effective sludge removal is usually obtained this way. However, the most efficient reduction of dissolved solids concentration is not at this point in the boiler. In water-tube boilers, concentrations are generally highest at the place where the mixture of steam and boiler water from the tubes spills over into the steam drum. Where total concentrations are not reduced sufficiently by the bottom blow, another blowdown line may be installed to remove water from the drum at the point where concentrations are highest. Such a blowdown is generally operated continuously when the boiler is operating and is therefore called the continuous blow-down.

Exercises (638):

1. How does dissolved mineral matter enter the boiler?
2. Identify the methods of blowdown used with steam boilers.

639. Specify the procedures for blowing down a boiler and water column.

For greatest economy in boiler operation, the rate of boiler blowdown is controlled to

carry the concentration of dissolved solids in the boiler as high as practical without causing difficulties. How high the concentration can be safely carried depends on the particular installation. To determine the limit for a given plant, the concentration can be gradually built up while the boiler carries the type of load to be expected in the plant; samples of condensed steam and of boiler water can be taken for analysis at the same time. The concentration of dissolved solids in the boiler water at the time that appreciable carry-over first appears in the steam is the upper limit below which the boiler-water concentration must be carried.

In addition, the rate of blowdown must be sufficient to prevent accumulation of excessive sludge in the boiler, formation of excessive causticity, and formation of certain scales resulting from high boiler-water concentrations.

For average conditions in plants of the type covered by this text, difficulties due to excessive concentrations can generally be controlled by blowing down sufficiently to keep the concentration of dissolved solids below about 4000 ppm. Although this value is arbitrarily chosen, for average cases the rate of blowdown required to keep the concentration below this limit is reasonable, say under about 5 percent. Adequate sludge removal is also generally obtained, excessive causticity resulting from high concentrations is avoided, and there is no excessive loss of treating chemicals. A rate of blowdown much over 5 percent is generally considered wasteful.

Operation of Blowdown Valves. Before operating any blowoff valve, be sure the discharge of hot water will not cause any damage. Usually, blowoff valves discharge into flash tanks from which the water is drained harmlessly to a sewer or other appropriate place. Do not open a blowoff valve to drop the water level of a boiler without ascertaining that the water level really is high. Check at the water column, as operators have damaged boilers by blowing them down on the assumption that since the water level was not visible in the gage glass it was high. When the operator, blowing down the boiler, cannot see the gage glass, another operator should be placed where he has a full view of the water glass; and he can signal the first operator

When continuous blowdown systems are used to control the boiler water concentration, the main blowoff valves should be used periodically to prevent stuck stems. These valves should also be used to remove

sludge accumulations from the mud drum. Boilers should be blown down during reduced load operation. More sludge can be removed when the rate of water circulation is low. To blow the boiler down, open the valve next to the boiler first; then open the valve farthest from the boiler; blowdown the boiler as required; close the valve farthest from the boiler; and last, close the valve next to the boiler.

This procedure will minimize the wear on the valve next to the boiler, since the second valve will do all the throttling. Some manufacturers recommend different procedures, therefore, always refer to the instructions for your particular set of valves. Where a slow-opening and a quick-opening valve are used in combination, the quick-opening valve should be opened first and closed last.

Operation of Continuous Blowdown System. Continuous blowdown flow is usually controlled by hand-operated V-port valves with indicating dials and pointers. A definite amount of water is discharged for each position of the pointer. Sometimes, to keep total boiler-water solids concentration independent of load variations, the amount of blowdown is set as a definite percentage of the boiler feed

Operation of Gage Glass Blowdown. Blow down gage glasses only when necessary, and then do it gently. Excessive blowing down of gage glasses roughens the glass. Usually, when the water column is blown down, the gage glass is sufficiently cleaned. To blow down a water glass, close the top shutoff valve; open the gage glass drain valve slowly, this will permit the boiler water to flow through the bottom connection, thereby cleaning it; open the top shutoff valve slowly; close the bottom shutoff valve, steam will flow through and clean the top connection; close the gage glass drain valve; open the bottom shutoff valve slowly. After finishing the operation, be sure that both top and bottom shutoff valves are completely open and that the drain valve is tightly closed.

Operation of Water Column Blowdown. In high pressure installations, the drain line usually has an orifice to restrict the flow. If two drain valves, in series, are provided, open the valve next to the water column first, and then open the other valve. Blow down the water column. First, close the valve farthest from the water column and then the valve next to the water column. This procedure assures that the valve next to the water column is kept tight since most wear will be produced in the second valve.

412

405

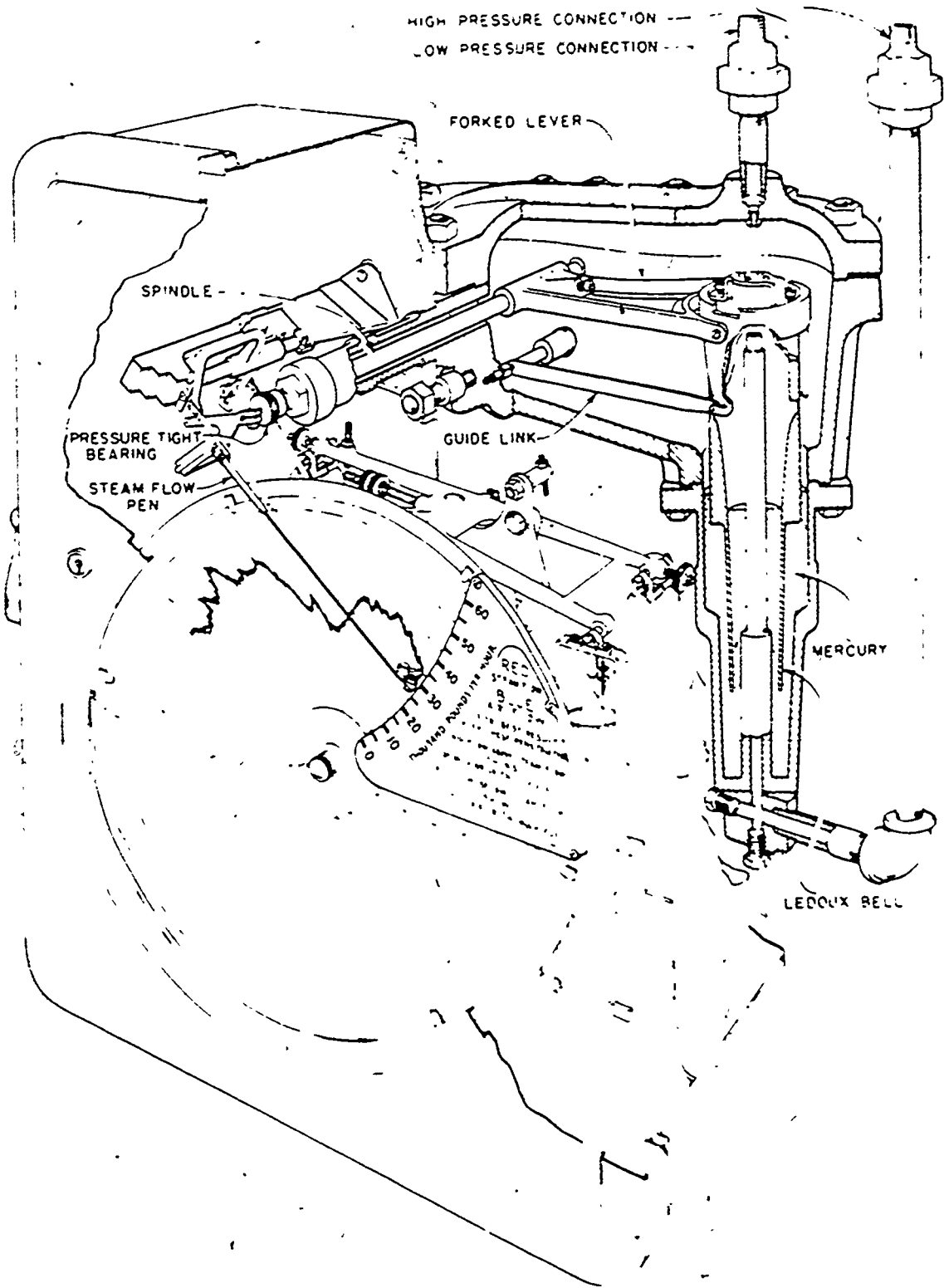


Figure 2-30. Steam-flow, air-flow meter.

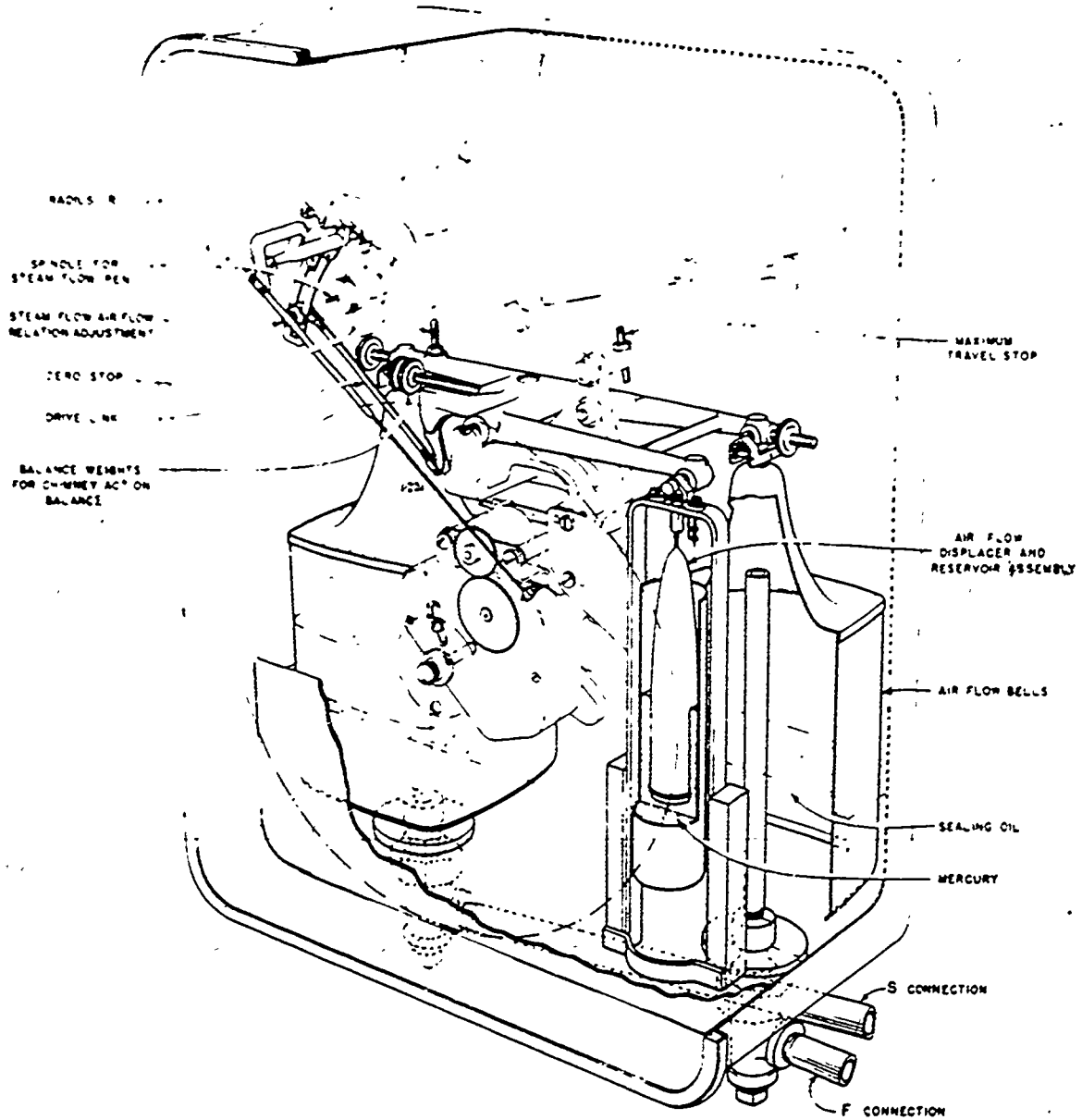


Figure 2-31. Air-flow section of steam-flow, air-flow meter.

Exercises (639):

1. Specify the procedures for operating valves used to blow down a boiler.
2. Explain how a continuous blowdown system functions.
3. Why should gage glasses only be blown down when necessary?

4. Specify the procedures for blowing down a water column.

640. List the instruments used to determine draft, identify the types of boiler draft controls, and state the factors that determine the number and type of instruments and controls to be used.

Steam generating requirements and the

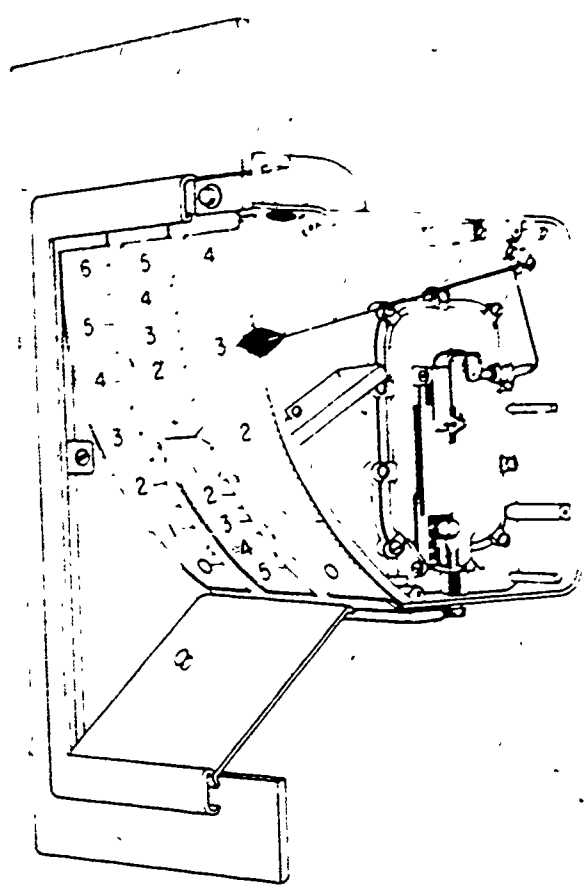


Figure 2-32. Diaphragm-type draft gage.

importance of the installation determine the number and type of instruments and controls used. For a small hand-fired boiler, a steam pressure gage, boiler feedwater gage, and furnace and stack draft gages with a flue gas thermometer may be all that is required. Larger plants with automatic combustion control and a considerable amount of auxiliary equipment may require a large amount of instrumentation. The following paragraphs discuss the methods of measuring boiler draft so it can be controlled.

Steam-Flow, Air-Flow Meter. Figure 2-30 illustrates one type of steam-flow, air-flow meter. The steam-flow section consists of a bell floating in mercury (secondary element). The localized pressure drop created by the primary element in the steampipe is transmitted to the bell through the low- and high-pressure connections shown. In operation, as flow through the primary element varies, the mercury level changes and the bell rises or falls accordingly. The motion of the bell is transmitted to a small shaft and through a pressure-tight bearing to the linkage, which operates a pen that records the flow rate on a chart. Because of the special

shape of the bell (called a Lecloux bell), its movement is directly proportional to the change in flow.

Air Measurement (Steam-Flow, Air-Flow Meter). The functioning of this meter is based on the fact that the amount of air supplied to a furnace is related to the amount of flue gas that passes through the setting. The gas flow, therefore, indicates the air actually supplied to the furnace. Resistance to the flow of combustion gases through the setting causes a pressure drop (draft loss) similar in effect to the localized drop created by a primary element in a steampipe. The "S" connection shown in figure 2-31 is installed in the setting at the point of higher draft; the "F" connection, at the point of lower draft. The secondary element consists of two air-flow bells, supported from knife edges on a beam which pivots on other knife edges, and a mercury-displacer assembly hanging from a knife edge on the beam. The bottoms of the bells are connected to the two points (S and F) of the boiler setting. In operation, changes in gas flow produce movements in the beam, which are transmitted through linkage to the pen that records the airflow. The parabolic shape of the mercury displacer makes the movements of the beam directly proportional to the changes in gas flow. This meter can be calibrated so that both steam-flow and air-flow pen recordings run together when the desired amount of air is supplied. Then, if too much air is supplied, the air-flow pen moves higher on the chart than the steam-flow pen; if too little air, it moves lower.

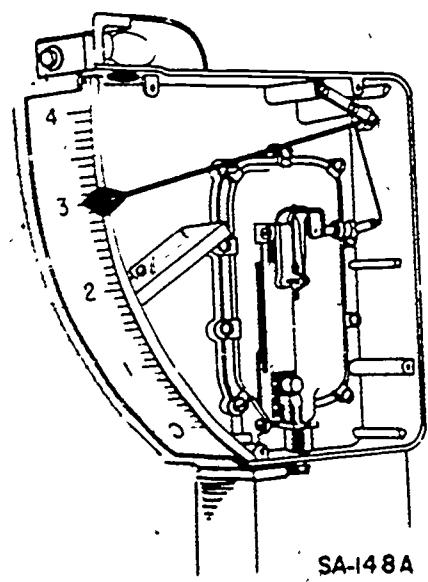


Figure 2-33 Diaphragm measuring element

Draft Gages. The draft gage is used to measure very low pressures. In boiler practice, a pressure difference that produces a gas flow is called a draft. Draft gages can be made as indicators, recorders, or both.

U-tube. The simplest type of draft gage consists of a U-tube partly filled with water. One leg of the tube is connected to the source of the draft and the other is left open to the atmosphere. The difference in level between the liquid in the two legs gives the draft in inches of water. In some models, one leg of the U-tube is arranged on an incline to increase the distance covered by the liquid in the inclined portion for a given draft change. The slope normally used is 1 inch in 10. Other types of draft gages use diaphragms or bellows as the measuring element.

Diaphragm type. Figures 2-32 and 2-33 illustrate a diaphragm-actuated draft gage. In operation, one side of the diaphragm is connected to the source of draft and the other is open to the atmosphere. The motion of the diaphragm is transmitted to the indicating pointer through proper linkage. This type of gage may be used also to measure small pressures above atmospheric, such as windbox pressures.

Stack Draft. When a gas is heated, its density decreases. During operation, the stack is full of gases that are hotter than those of the surrounding atmosphere. Therefore, the weight and pressure of a column of gas at the base of the stack is less than those of a similar column of atmospheric air. This pressure difference produced by the stack is called natural draft. The amount of draft produced by a stack depends on its height and the difference between the average temperature of the stack gases and the outside air. Often, the amount of natural draft that can be obtained is insufficient, then mechanical draft must be used.

Mechanical Draft Systems. These systems may be classified as forced draft, induced draft, and balanced draft. In the forced draft system, combustion air is pushed through the air ducts, air preheater, windbox, burners or fuel bed, and any other resistance between the fan discharge and the furnace. Induced draft systems must develop enough draft to draw the required quantity of combustion air through all the resistances described for forced draft. The balanced draft system is a combination of the forced draft and induced draft systems. The most common ways to control the boiler draft are: outlet control damper, inlet vane control, variable speed control, magnetic coupling, hydraulic coupling, and special mechanical drives. An

explanation on the operation of these various controls was covered in the information under Learning Objective 267.

Exercises (640):

1. State the factors that determine the number and type of instruments and controls that will be used.
2. List the instruments that are used to determine boiler draft.
3. Identify the types of controls used to control boiler draft.

641. List the tasks involved in performing a preoperational check of the boiler draft control and specify the operational checks made for normal fan operation.

Operational Checks of Draft Controls. An operational check of boiler controls would include the preliminary inspection of draft fans and normal operating conditions for the fans. Also, proper conditions of operation for draft instruments and meters should be checked. To make an operational check, it is essential to know how the equipment is supposed to function and the probable discrepancies that may occur.

Draft fan preliminary inspection. Prior to operating a draft fan, make sure that the following prestart requirements are fulfilled. (1) all installation, repair, and cleanup work is completed; (2) fan and drive properly lubricated with an approved lubricant; (3) steam and exhaust lines warmed and drained of condensate up to fan drive valve (if fan is steam-driven); (4) rotation checked and corrected, if necessary; (5) bearing cooling water supply at correct pressure and temperature, if used; (6) dampers almost closed (20 percent of full open position), as this reduces the load on the drive when the fan is started; and (7) turn the fan by hand to check for rubbing or binding.

Starting up. In a balanced draft system, always start the induced draft fan before starting the forced draft fan. To start the fan, first start the cooling water supply to the bearings (if applicable). Then, momentarily

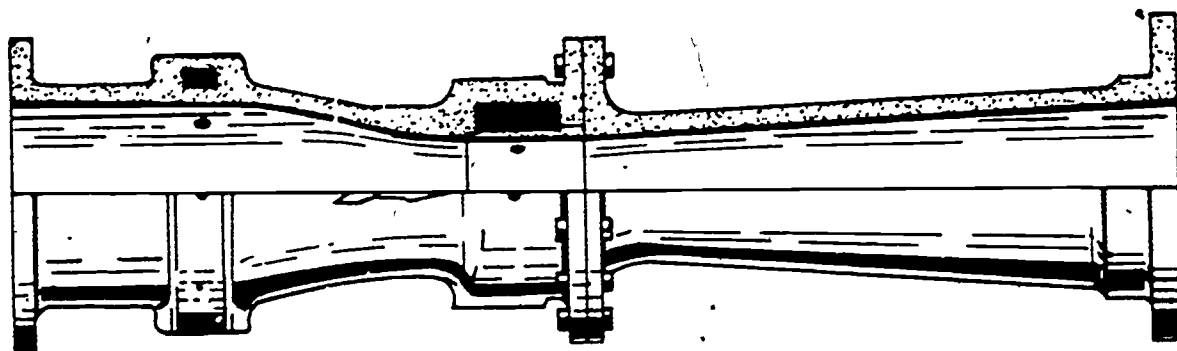


Figure 2-34. Venturi tube for flow metering.

start and stop the fan to check for abnormal vibration, noise, and rubbing. If it tests satisfactory, start the fan again and open the dampers to normal position.

Normal fan operation. During an operational check for normal operation, regulate bearing cooling waterflow for proper bearing temperature. Overcooling may cause condensation of moisture inside the bearings. Usually, a bearing operating temperature of 130° F. or less is considered satisfactory, however, do not cool below 100° F. Periodically, observe and record all readings taken from fan thermometers, pressure gages, and draft gages. Report immediately, or take action, as required, if any abnormal conditions are observed.

Operational check of instruments and meters. On a daily basis, inspect for correct operation of instruments and meters under load changes. At least monthly, blow out all furnace pressure connections with compressed air. Only trained personnel should place in service or remove from service, or calibrate and maintain, flowmeters. Wind hand-wound chart drives with 24-hour movements at the same time each week. Replace recording charts at the same time each day (usually at 2400 hours). Be sure to date the chart and mark it for proper identification. Inspect for leaks and correct operation. Mount properly to eliminate any undue vibration that may affect operation. Check for defects such as leaks, broken or cracked glass, and inadequate lighting. Do not oil the pressure gage mechanism.

Exercises (641):

1. List the tasks involved when performing a preoperational check of a boiler draft control.
2. Specify the tasks that should be

accomplished when performing an operational check during normal operation.

642. Specify the tasks involved when performing operational checks of typical automatic boiler controls and answer key questions about these controls.

To assure efficient and safe operation of a steam heating plant, the flows, temperatures, and pressures of the main fluids handled must be measured. Several types of measuring instruments and meters are available. There are recording, indicating, and recording-indicating types. Pressure gages may be calibrated in pounds per square inch (psi), feet of water, inches of water, or inches of mercury according to pressure and fluid type. Thermometers and temperature recorders are usually calibrated in degrees Fahrenheit, but some instruments used for laboratory work are calibrated in degrees Celsius. Instruments used to measure flow are ordinarily calibrated in pounds per hour, gallons per minute, or cubic feet per minute. Most flowmeters also have integrators which total the fluid flow. In addition to the automatic controls previously discussed under Learning Objective 641, we discuss flowmeters, temperature meters, level controls, temperature controls, and pressure controls.

Flowmeters. Flowmeters are instruments used to measure the rate of fluid flow. Often they are indicating-recording types, with integrators that total the amount of flow in a given period of time. The primary element in commonly used flowmeters is an orifice, flow nozzle, or venturi tube installed in a pipe or duct (see fig. 2-34). The operating principle is the same in all three types. The primary element produces a localized pressure drop in

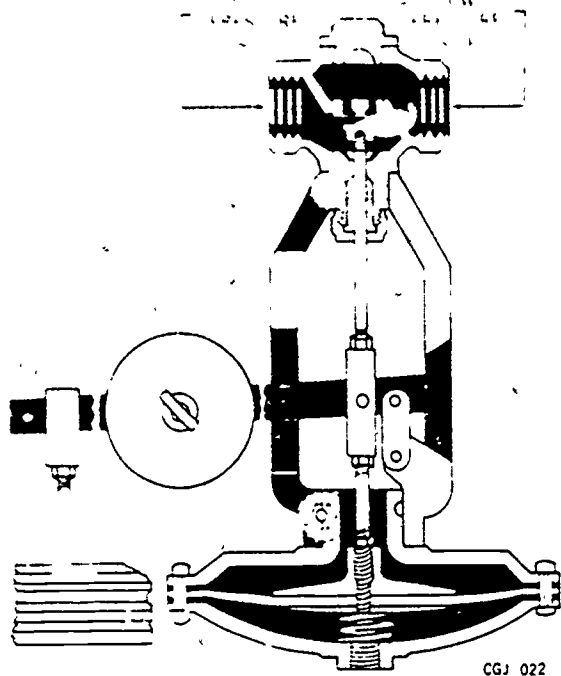


Figure 2-35 Weight and lever pressure-reducing valve.

the line. The amount of pressure drop depends on the rate of flow of the fluid. Commercial flowmeters have an orifice, flow nozzle, or venturi tube, and a secondary element to measure and translate the pressure drop into pounds per hour, cubic feet per second, gallons per minute, or any other unit desired.

Temperature Meters. These instruments are used to measure the temperature of a fluid. They can be indicating (generally called thermometers) or recording types. The most common thermometer consists of a glass tube from which the air has been removed. The upper end is closed; the lower end is expanded into a bulb and filled with a suitable liquid, such as mercury. When the bulb is heated, the liquid expands and rises in the tube. It contracts and drops when the bulb is cooled. Expansion of the liquid in the tube is proportional to the intensity of the heat. Divisions marked on the tube, or on an adjacent surface, indicate the degrees of temperature. Thermometers for remote indication may consist of a gas-filled system that includes a bulb, capillary tubing, and a helical coil. Temperature changes at the bulb end actuate the coil at the other end. Length of capillary tubing varies with bulb size. This type of thermometer can be adapted for recording by attaching a pen through proper linkage at the free end of the helical coil. The

pen records on a chart, mounted on a rotating assembly, which is operated by clockwork or a synchronous electric motor.

Level Controls. Level controls are used to maintain a substantially constant level of fluid in a tank, boiler, or other vessel. The level control is usually a float, which measures level changes caused by imbalance between the in-and out-flow and actuates a valve to restore the balance. The float can be directly connected to the control valve for a positive displacement type of feedwater regulator. In other types, the float operates a relay mechanism or pilot valve which, in turn, operates the control valve. Air, steam, or oil can be used to operate or position the controlled valve. Often, the float operates a switch to start or stop an electrically driven pump, as the level rises or falls.

Temperature Controls. Temperature controls consist basically of three elements: a temperature sensing device (temperature bulb), a regulating valve actuated by a bellows to control the passage of the fluid, and capillary tubing to connect the temperature bulb with the bellows. The temperature bulb, capillary tubing, and bellows system are filled or partly filled with liquid, gas, or a combination of liquid and vapor. In operation, temperature changes at the bulb

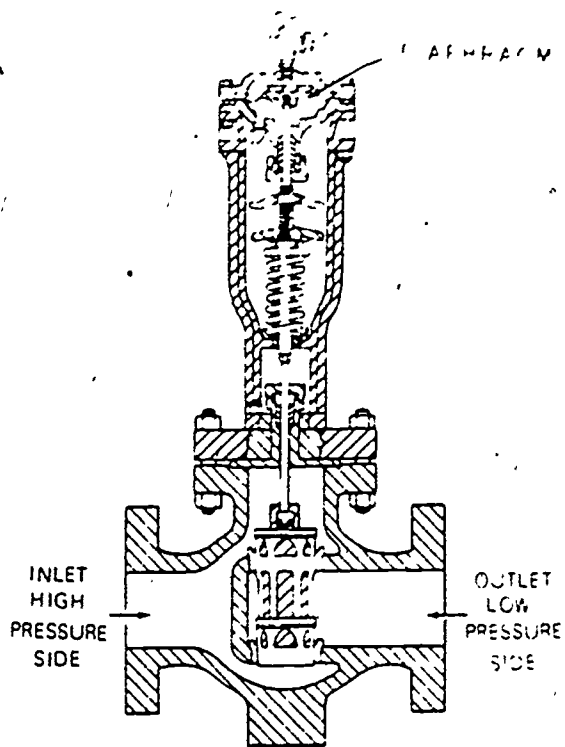


Figure 2-36. Spring-loaded differential pressure valve.

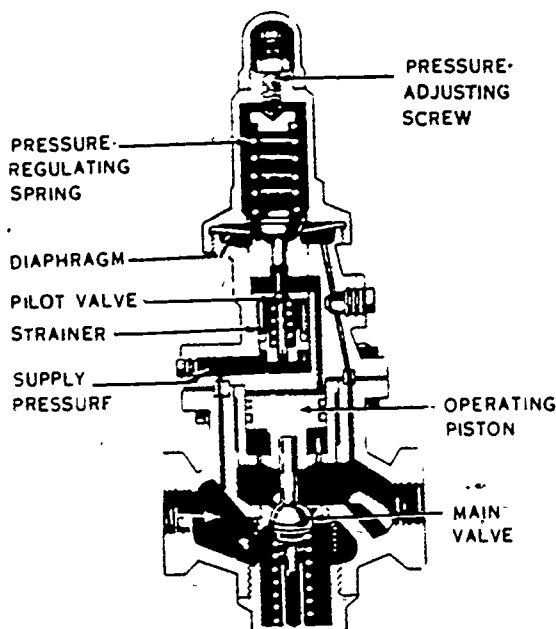


Figure 2-37. Pilot-valve-operated pressure regulator.

produce expansion or contraction of the medium that fills the system. This, in turn, causes expansion or contraction of the bellows, actuates the valve, and moves the valve stem. The expansion movement of the bellows is opposed by an adjustable compression spring or a weighted lever area. The controlled temperature can be adjusted by changing the compression of the spring or the position of the lever weight.

Pressure Controls and Pressure-Reducing Valves. Pressure controls are of two types, used for two general purposes: to maintain a substantially constant pressure in one part of the system, while the other part fluctuates or changes its pressure within the range limits; and to maintain a definite difference in pressure between two points and control the flow of a fluid. An example of the first type is the pressure-reducing valve. This device controls flow (steam, gas, or air) through the valve to maintain a definite pressure in the discharge side of the valve while the inlet pressure changes. The second type is often used in boiler feeding to maintain a fixed pressure difference between the water supplied at the inlet of the feed valve and the valve discharge (boiler steam-drum pressure). The control may consist of a device which operates the regulating valve directly (self-operated) or through a pilot or relay valve (pilot-operated). The operating device positions the regulating valve to maintain the desired conditions. Figures 2-35 and 2-36 illustrate pressure regulators of the

self-operated type; figure 2-37 shows a pilot-operated pressure regulator. Self-operated pressure control valves may be either weight-loaded or spring-loaded. Pilot-operated pressure control valves are operated by either internal or external pilot valves.

Weight-loaded valves. Figure 2-35 illustrates a diaphragm-operated pressure-reducing valve. The low pressure side (controlled pressure) is connected below the diaphragm. The controlled pressure is adjusted by changing the weight or its lever position.

Spring-loaded valves. Figure 2-36 shows a diaphragm-operated, spring-loaded differential pressure valve. When used as a pressure-reducing valve, the controlled pressure is applied to the top chamber over the diaphragm and the diaphragm movement is directly transmitted to the control valve through the valve stem. In operation, an increase in the controlled pressure pushes the diaphragm against the resistance of the spring. This pressure closes the valve until the controlled pressure and the spring force are balanced. The controlled pressure can be adjusted by changing the spring compression.

When the regulator is to be used as a differential pressure controller, the higher pressure is connected to the top chamber over the diaphragm and the lower pressure to the lower chamber below the diaphragm. The spring force is used to make up the difference between the two pressures. A change in spring compression will adjust the amount of pressure differential.

Pilot-operated valves. Figure 2-37 illustrates an internal pilot-operated valve with an operating piston. It functions as follows: The valve discharge pressure acts on the bottom of the diaphragm and pushes it up against the force exerted by the pressure-regulating spring. The diaphragm finally assumes a position dependent upon these two forces. A spring holds the pilot valve against the diaphragm; therefore, any movement of the diaphragm causes a corresponding movement of the pilot valve. One side of the pilot valve is connected to the supply pressure; the other side, to the top of the operating piston, which is in permanent contact with the main valve.

A spring underneath the main valve holds it against the operating piston at all times, thereby keeping the valve closed and the operating piston up. When the valve is in equilibrium, there is enough flow through it to keep the discharge pressure at the required level. When pressure on the discharge side drops, a corresponding drop under the diaphragm allows the spring to force the

diaphragm down and open the pilot valve. More fluid from the supply side then passes through the pilot valve, builds up pressure on top of the operating piston, and moves it down against the spring compression. This pressure opens the main valve, thereby increasing the flow and building up pressure in the discharge side until the valve is again in equilibrium. The procedure is reversed when the pressure on the discharge side increases. To regulate the pressure on the discharge side, adjust the compression of the pressure-regulating spring.

Operational Check of Flowmeters. Inspect the meter installations for the following:

- Leaks in piping or meter.
- Corroded, eroded, worn out, or otherwise defective parts.
- Plugged internal passages.
- Clogged pipes, tubing, or connections.
- Loose connections.
- Defective gaskets, diaphragms, or bellows.
- Dirt or foreign material.
- Short circuits, open circuits, defective transformers, grounds, or defective insulation in electric-type meters.
- Defective operation of clockwork mechanism or electric motor.
- Binding of moving parts.
- Incorrect meter calibration.
- Mercury contamination.

Operational Check of Level Controls. Be sure to keep the stuffing box leaktight when the system is operating. But do not tighten it enough to produce binding and prevent free operation of the equipment. Periodically, blow down independent float boxes and check operation of the float and lever mechanisms. Once a year, or more often if required, dismantle the equipment, clean all parts, and inspect for the following: erosion, corrosion, or wear of float-lever system; punctured float; defective condition of stuffing box and packing; and improper condition of valve, seats, and guides. Look for evidence of wire-drawing. Repair or replace defective parts, as required.

Operational Check of Temperature Controls. Only authorized and trained personnel should repair, calibrate, or adjust temperature controls. When steam flow is controlled by temperature controls, slowly warm up the line and drain the condensate before operating the regulating valve. Blow down strainers and clean the baskets at regular intervals or whenever necessary.

Daily. Observe operation of the control for proper functioning. Check leaks. Stop stuffing box leaks as soon as possible.

Yearly. Once a year, or more often if required, dismantle valve and control mechanism, clean components, and inspect for wear, corrosion, erosion, pitting, deposits, leaks, or other defects. Check settings, adjustment, and control operation. Repair or replace defective parts, as required, after the yearly inspection. Examine valve stem; replace or metalize, if necessary. Change or regrind valve and seat, as required. Change valve to smaller size if excessive cutting indicates an oversize valve. Repack stuffing box. Observe condition of bellows, diaphragms, etc. When installing, connecting, or disconnecting capillary tubing, protect it from dents or kinks. Any restriction to the flow of liquid, gas, or vapor in the tube will cause defective operation of the temperature control.

An operational check of pressure control and pressure-reducing valves would involve the requirements that were discussed for temperature controls. The maintenance instructions for temperature controls will also apply to pressure controls. The only exception is to disregard the maintenance instructions pertaining to handling capillary tubing as it does not apply to maintenance of pressure controls.

Exercises (642):

1. What types of pressure readings are measured with pressure gages?
2. State the purpose of a flowmeter.
3. What causes the expansion of a liquid used in a glass thermometer?
4. Why is a level control used?
5. Explain the operation of a temperature control.
6. Relate the two general purposes of pressure controls.



<i>Capacity of Plant</i>	<i>Operating Pressure</i>	<i>Fired By</i>	<i>Frequency of Operational Visits</i>
Up to 360,000 Btu/hr	15 psi steam or 30 psi water max. or warm air	Gas Oil Stoker	One per month One per month Two per day
360,000 to 1,680,000 Btu/hr	15 psi steam or 30 psi water max. or warm air	Gas Oil Stoker	One per week One per week Two per day
1,680,000 to 4,800,000 Btu/hr	15 psi steam or 30 psi water max. or warm air	Gas Oil Stoker	Two per week One per day Two per 8 hr. shift
4,800,000 to 14,400,000 Btu/hr	15 psi steam or 30 psi water max.	Gas Oil Stoker	One per day One per 8 hr. shift Three per 8 hr. shift
Up to 1,400,000 Btu/hr	Over 15 psi steam or 30 psi water	Gas Oil Stoker	Three per week Three per week Two per 8 hr. shift
1,400,000 to 3,500,000 Btu/hr	Over 15 psi steam or 30 psi water	Gas Oil Stoker	One per day One per 8 hr. shift Three per 8 hr. shift
3,500,000 to 14,000,000 Btu/hr	Over 15 psi steam or 30 psi water	Gas Oil Stoker	Two per 8 hr. shift Two per 8 hr. shift Four per 8 hr. shift
Over 7,000,000 Btu/hr	Over 15 psi steam or 30 psi water	Coal Hand-fired	Constant attendance as follows: 2 men per 8 hr. shift, plus coal and ash handling personnel consistent with installed equipment.
14,000,000 to 100,000,000 Btu/hr	Over 15 psi steam or 30 psi water	Gas Oil Stoker	Constant attendance as follows: 1 man per 8 hr. shift for Gas or Oil. One or two men per 8 hr. shift for stoker, plus coal handling personnel consistent with installed equipment.
Over 100,000,000 Btu/hr	Over 15 psi steam or 30 psi water	All Fuels	Constant attendance in accordance with installation requirements.

CG-066

Figure 2-38. Manning requirements.

7. Specify the tasks involved when performing an operational check of the following automatic boiler controls:

- a. Flowmeters.
- b. Level controls.
- c. Temperature controls.

2-5. Operating Logs

Civilian and military personnel may operate any heating plant, regardless of size or type, if they are qualified to perform the duties assigned and the basic civil engineer so certifies. Part of the duties of the boiler plant operator entail the maintenance of the operating logs. In this section, we discuss the required reports, how to transcribe meter information, and computation of the required information.

643. Cite the purpose of operating logs and specify when logs are required.

AF Form 1458 will be used by all installations operating steam boiler plants having capacities greater than 1,680,000 Btu/hour for low operating pressures (15 psi maximum) and 1,400,000 Btu/hour for operating pressures over 15 psi. Each time an operator makes a visit to a heating plant which is not constantly attended, in accordance with the frequency of operational visits noted in AFM 85-12, he will enter the appropriate information obtainable from the existing permanently installed instrumentation on AF Form 1458. Each operating shift at constantly attended steam plants will complete AF Form 1458. Post information from AF Form 1458 daily on AF Form 1464, Monthly Steam Boiler Plant Operating Log. Some of the instrumentation from which data for this log is obtained is described in AFMs 88-15 and 85-12. Where there is more than one plant, a separate log is required for each separate plant.

Column A. Hour and minute when each set of observations is started. (Military Time 0-2400 HRS).

Column B. Steam pressure from steam-gage readings.

Column C. Steam produced in units of 1000 pounds from steam flow or feedwater meters for each boiler and computed by subtracting the current reading from the previous reading.

Column D. Enter Btu value per unit fuel used. Enter the quantity of fuel used in the boiler columns. Coal = the pounds of coal burned from actual weighing or estimated usage. Oil = gallons of oil from meters or tank gaging. Gas = thousands of cubic feet as taken from gas meter.

Column E. Record the CO₂ in the flue gas from each boiler and the temperature in degrees F. These temperatures will be taken at the point immediately after gases have passed the last heating surface in each boiler. (The readings of CO₂ and stack or flue gas temperatures must be accurate. Check instruments frequently.)

Column F. For each boiler (1) under fire draft in inches of water; (2) furnace over fire draft; (3) last pass draft as taken at the boiler exit.

Column G. (1) Pressure readings are taken from the shell of the heater. (2) The temperature of the feedwater is taken immediately after water passes over the trays or sprays, at the highest water level.

Column H. The total amount of feedwater to all boilers in gallons from feedwater meter.

Column I. The metered gallons of makeup water.

Column J. The temperature of return condensate. The temperature of the condensate returned to the surge tank or pump receiver.

Column K. The suction and discharge pressures.

Column L. Outside ambient temperature.

Column M. The kilowatt hours used during the day for the entire plant, if metered.

Item 5. Operating Data:

A thru C. Self-explanatory.

D. Pounds of steam per unit of fuel - Divide total pounds of steam produced during each shift (column C), by the total units of fuel used to produce the steam (column D), coal in pounds, oil in gallons, and gas in thousands of cubic feet.

E. Time of blowing under the appropriate shift.

F. The volume of blowdown per gage glass may be initially determined by shutting off the feedwater, blowing down, then obtaining the quantity of feedwater necessary to restore normal water line from the feedwater meter. Other methods may be used. Record the number of gallons of blowdown on the line under the appropriate shift. If blowdown is continuous, note same. Allow 8.3 pounds per gallon of blowdown to determine total weight of blowdown.

BE-1458B

Figure 2-39. AF Form 1458 instructions, part 1,

G. The degree days for each day of operation are obtained by adding the maximum and the minimum outside temperature during the 24-hour period, dividing by 2 and subtracting from 65. Negative results will not be entered.

$$\text{Degree Days} = 65 - \frac{(^{\circ}\text{F Max (Column L)} + ^{\circ}\text{F Min (Column L)})}{2}$$

H and I. Self-explanatory.

J. The total man-hours used for operation of the plant, excluding administrative time and outside system maintenance.

Item 6. From applicable efficiency charts in Vol. I AFM 85-12, for the fuel used, based on daily average CO₂ readings and stack temperatures, obtain combustion efficiency for each boiler. Calculate the average efficiency by adding all boiler efficiencies and dividing by the number of operating boilers. When more than one fuel is used indicate efficiencies for each fuel.

Item 7. Multiply the total steam produced (item 5C) by the enthalpy of the steam at the operating steam pressure and temperature minus the enthalpy of the feedwater at the feedwater heater temperature (column G), from steam tables and divide by one million. (Steam tables available in AFM 88-54 for saturated steam.)

$$\frac{\text{Total steam produced (item 5C)} \times (\text{Enthalpy of steam} - \text{Enthalpy of Feedwater})}{1,000,000}$$

Item 8. Multiply the total units of fuel used (item 12) by the calorific value per unit of fuel (column D) and divide by one million.

$$\frac{\text{Total fuel used (item 12)} \times \text{Calorific value of fuel (column D)}}{1,000,000}$$

Item 9. Divide plant Btu output (item 7) by plant Btu input (item 8) and multiply by 100.

$$\frac{\text{Plant Btu Output (item 7)}}{\text{Plant Btu Input (item 8)}} \times 100$$

Item 10. Figures are computed by dividing the rate of steam flow for the one hour period having the largest output by the sum of the design pounds per hour steam flow rating at the working temperature and pressure of all the boilers in operation contributing to the steam flow and multiply by 100. This factor should be used as a guide for operation of the optimum number of boilers for maximum efficiency.

$$\frac{\text{Highest Hourly Total Output (Column C)}}{\text{Design Output rating of boilers in operation}} \times 100$$

Item 11. Divide pounds of makeup water flow by the total pounds of steam flow or feedwater flow, and multiply by 100. Allow 8.3 pounds per gallon to determine the weight of water.

Item 12. Add the total daily quantities of each fuel used by each boiler in column D.

Item 13. May be continued on reverse of form, if additional space is required.

The signature of the Chief Operating Engineer on AF Form 1458 indicates his approval of the operation of the plant, unless comments in the remark column indicate otherwise.

BE-1458C

Figure 2-40. AF Form 1458 instructions, part 2.

How would you like to pay a fuel bill of \$50,000.00 a month? If you had a bill of this size, you would surely want to get the heating value you are paying for. Your base may have a comparable fuel bill that must be paid just as homeowners have fuel bills that must be paid. The Government pays its bills from public funds, which come from our taxes. Government agencies are charged by the Congress to be prudent in the expenditure of these funds. As an aid and management tool to satisfy this congressional requirement, the Air Force has developed reporting procedures to enable it to monitor fuel consumption for heating. These reports begin in the heating plant with us. If we compile a report that is not accurate and factual, we are deceiving ourselves and our supervisors.

Steamplant Operating Logs. AF Form 1458, Daily Steam Boiler Plant Operating Log, provides the means of recording, on an hourly basis, continuous data that can affect the operation of all central steamplants. The information on the daily log should be transcribed to AF Form 1464, Monthly Steam Boiler Plant Operating Log, each day, using the information compiled and computed on AF Form 1458. Each operating shift at constantly attended steamplants (manning requirements are shown on fig. 2-38) will make entries on the daily form and post the completed information from this form to the monthly log. Each time an operator makes a visit to a central heating plant that is not constantly attended, he enters the appropriate information on AF Form 1458 and then posts it on AF Form 1464. Frequency of visits and the corresponding log entries are, as indicated, in figure 2-38.

Exercises (643):

1. Cite the purpose of the Air Force forms that are used as operating logs.
2. What is the source of information that is posted on the monthly log, AF Form 1464?
3. Specify the conditions that will require an operating log to be maintained.

644. Make the normal computations used in maintaining daily and monthly logs for steam heating systems and answer key questions about the maintenance of these logs.

The instructions for completing the logs are printed on the reverse side of the forms. Figures 2-39 and 2-40 are reproductions of the reverse side of AF Form 1458. Figure 2-41 is the front side of AF Form 1458. Figures 2-45 and 2-46 are reproductions of the reverse side of AF Form 1464, and figure 2-47 is the front side of the form. The instructions that we discuss are an elaboration on some of the tasks involved in maintaining the daily and monthly logs for steam heating systems.

Daily Operating Log. Study AF Form 1458 (fig. 2-41) and carefully read the instructions about filling out this log (figs. 2-39 and 2-40). Then return to the following discussion of some of the hourly data that is required to complete the log correctly.

Hourly data. Every hour, certain readings are taken and recorded on AF Form 1458. In column A, record the hour and minute when you start the readings. In most plants, readings start at 0100 hours and end at 2400 hours at exact hourly increments.

In column B, record the average boiler pressure for all producing boilers in the plant in whole numbers. In column C, record the steam flow of each boiler in thousands of pounds per hour. If you are operating boiler No. 1, for example, and the flowmeter integrator indicates that it has produced 32,000 pounds of steam, you enter 32.0 under boiler No. 1 in this column. If there is a single flowmeter for the plant rather than one for each boiler, place a checkmark in the column for each boiler that is operating and compute the steam produced on a shift basis in item 5. Use the start and stop reading of the integrator with the appropriate meter factor. The numbers 1 and 3 in the shift column of item 5 indicate individual operating boilers; each boiler has its own flowmeter.

Record the amount of fuel used for each boiler in column D. Enter pounds for coal, thousands of cubic feet (MCF) for gas, and gallons for oil. At the heading of the column, enter the calorific value for the fuel used. If more than one fuel is used, enter both quantities and define both types at the heading of the column. In some plants, it is not economical to record fuel consumption on an hourly basis. Instead, the total is determined for each shift or each day. If this

2417

DAILY STEAM BOILER PLANT OPERATING LOG														1. COMMAND HQ COMMAND (USAF)			
TIME PERIOD	STEAM PRESS (PSIG)	STEAM PRODUCED (1000 POUNDS)				FUEL USED				FLUE GAS							
						COAL - BTU/LB				CO ₂ (Percent)				TEMP. (Deg. F)			
		GAS - BTU/MCF				BOILER NO.				BOILER NO.				BOILER NO.			
1	2	3	4	1	2	3	4	1	2	3	4	1	2	3	4		
0000-0030	32.0	32.4	280	280	12.1	12.0	580	590									
0100-0130	32.4	32.4	280	280	12.0	12.0	580	590									
0200-0230	32.8	32.8	280	280	11.9	11.9	590	600									
0300-0330	32.8	32.8	290	280	12.0	11.9	590	600									
0400-0430	33.2	33.6	290	290	12.0	12.0	590	600									
0500-0530	33.2	33.6	290	290	11.9	12.1	580	590									
0600-0630	33.6	33.2	280	270	12.1	12.1	580	590									
0700-0730	33.6	33.2	290	270	12.1	12.1	590	590									
0800-0830	32.0	33.0	285	280	12.0	12.0	585	594									
0900-0930	33.2	33.6	290	290	12.0	12.0	580	590									
1000-1030	33.2	33.2	280	280	12.1	12.1	580	590									
1100-1130	32.0	32.4	280	280	12.1	12.1	580	590									
1200-1230	31.2	32.0	280	280	12.1	12.1	570	590									
1300-1330	30.4	30.0	270	260	12.1	12.1	570	580									
1400-1430	28.8	28.0	250	240	12.1	12.1	570	580									
1500-1530	28.8	27.2	250	240	12.1	12.1	570	580									
1600-1630	26.0	26.0	240	230	12.1	12.1	570	580									
TOTAL	242.0	242.0	2140	2100													
AVG	100	30.3	30.2	267	262	12.1	12.1	575	586								
1700-1730	26.4	26.4	240	230	12.0	12.0	580	580									
1800-1830	27.2	26.4	240	230	12.0	12.0	580	580									
1900-1930	28.0	27.2	250	240	12.1	12.0	580	590									
2000-2030	29.2	28.0	260	250	12.2	12.0	590	600									
2100-2130	30.0	29.6	270	260	12.1	12.1	590	600									
2200-2230	31.6	32.0	270	270	12.1	12.0	590	600									
2300-2330	32.0	32.4	270	270	12.0	12.0	590	600									
2400-2430	32.4	32.0	280	270	12.0	12.0	590	610									
TOTAL	236.8	233.6	2080	2020													
AVG	100	29.6	29.2	260	252	12.1	12.0	585	595								
TOTAL	743.2	739.6	6500	6360													
AVG	100	31.0	30.8	270	264	12.1	12.0	582	592								

OPERATING DATA				
	Boiler No. 1 - 1ST SHIFT	Boiler No. 3	Boiler No. 1 - 2ND SHIFT	Boiler No. 3
A STEAM FLOW FUEL (INTERGRATOR)	44 340	34 299	46 947	36 906
B STEAM FLOW STEAM	43 681	33 639	44 340	34 299
C TOTAL STEAM PRODUCED	659	660	607	605
D LBS. STEAM PER UNIT OF FUEL	116.7		114.3	
E SCOT BLOWN	0615		(NOT BLOWN)	
F BLOW DOWN	TIME #1-0230	GALS. 85	TIME #3-0930	GALS. 85
G DEGREE DAY				
H OPERATOR	R. Laddetter		W. Gregory	
I REWMAN	S. Fleming		R. Spright	
J TOTAL MANHOURS OPERATION	16		16	

REMARKS (CONTINUE ON REVERSE)

A. CONTINUOUS BLOWDOWN OPEN 5% - #1 & #3

B. (AIR TEMPERATURE 76°F) STEAM FLOW INTEGRATOR FACTOR IS 400

C. OIL ATOMIZATION TEMPERATURE - 180°F

D. NOTIFIED ENGINEER AT 1630 HRS THAT MAKE-UP WATER WAS INCREASING

E. MAKE-UP WATER BACK TO NORMAL AT 2200 HRS.

F. MAKE-UP WATER HAD DUE TO SUB-STATION CONDENSATE PUMP TRIP

DATE: 18 JAN 74

SIGNATURE OF CHIEF OPERATING ENGINEER: M/DET Dennis C Christenson

AF FORM 1458 PREVIOUS EDITIONS OF THIS FORM WILL BE USED UNTIL STOCK IS EXHAUSTED.

Figure 2-41. AF Form 1458 front side.



2. BASE AND LOCAT. ON ANDREWS AFB Md. (Washington DC 20331)										3. BUILDING NO. AND NAME #1792 West Flight Line		4. DATE 17 JAN 74								
5. NAME OF UNIT BOILER NO.										FEEDWATER HEATER		ELECTRICAL POWER USED								
NO.	DATE	TIME	INCHES	WATER	INCHES	WATER	INCHES	WATER	INCHES	WATER	PSIG	TEMP	WATER	WATER	WATER	WATER	WATER	WATER	WATER	WATER
13	02	19			13	02	21				35	221	500	180	15.0	125	24			
13	07	19			13	07	21				35	221	500	180	15.0	125	24			
13	02	19			13	02	21				36	221	600	179	15.0	125	22			
13	02	19			14	02	21				35	221	500	180	15.0	125	20			
3	02	24			14	02	23				36	221	500	181	15.0	125	19			
4	02	24			14	02	23				36	222	600	182	15.0	125	19			
4	02	24			14	02	23				35	222	600	180	14.9	124	19			
4	02	24			14	02	23				35	222	600	180	14.9	125	17			
													4400							
13	02	21			14	02	22				35	221	550	180	15.0	125	20			
14	02	24			14	02	24				36	222	500	180	15.0	125	19			
4	02	24			14	02	24				35	221	500	179	15.0	124	19			
13	07	23			14	07	23				35	221	400	180	14.9	125	20			
14	02	23			13	02	23				35	221	500	181	15.0	126	23			
13	02	22			13	02	23				35	221	400	182	15.0	125	27			
13	02	20			13	02	22				35	221	500	180	14.9	125	32			
14	02	20			14	02	21				35	221	900	179	15.0	125	32			
14	02	19			14	02	21				35	221	1000	180	15.0	125	32			
													4700							
14	02	22			14	02	23				35	221	550	180	15.0	125	25			
13	07	19			13	07	20				35	221	1100	179	14.9	125	31			
14	02	20			13	02	21				35	221	1400	178	14.9	126	30			
14	02	20			14	02	22				35	221	1700	177	15.0	125	30			
13	02	21			13	02	22				35	221	2000	178	15.0	124	28			
14	02	22			14	02	23				35	221	1000	178	15.0	125	26			
14	02	23			14	02	24				35	221	600	179	15.0	125	24			
14	02	24			14	02	24				35	221	400	177	14.9	125	22			
14	02	24			14	07	25				35	221	400	178	15.0	125	20			
													8600							
14	02	22			14	02	23				35	221	1075	178	15.0	125	26			
													17700							
14	02	22			14	02	23				35	221	737	177	15.0	125	24			

BOILER No 1	THIRD SHIF	BOILER No 3	BOILER No 1	3rd	BOILER No 3
45 339		35 482			
44 947		34 904			
592		584	1858		1849
	114.7				
	1830				
	#3-1730	100%	85	25.5	TOTAL GALLONS
				40:5	
	J Okille				
	F Harrison				
	16			48	
G. OVERALL EFFICIENCY COMPUTATION IS OIL FIGURES REFERENCED TO 60°F IN ACCORDANCE WITH U.S. DEPT. OF COMMERCE, NATIONAL BUREAU OF STANDARDS, CIRCULAR C-140. 2 MERX GALLONS 12.060 REPRESENTED IS 12.333 GALLONS.					
H	65.0	40.32°F	26.5		
	-26.5	17°F	2/49	DEGREE DAYS	
	40.5	49			

PERCENT COMPLETION	PERCENT	PERCENT
81.9		9.9
PERCENT OF OIL INPUT	PERCENT	
1,482.8		
PERCENT OF OIL INPUT	PERCENT	
1,874.6		
OVERALL EFFICIENCY	PERCENT	
79.0		
PERCENT DEMAND FACTOR	PERCENT	
79.7		

Figure 2-41. (Contd).

permissible at your plant, give an explanation in the Remarks section, item 13.

Enter the percentage of CO₂ in the flue gas of each boiler in column E. Record percentages to the nearest 0.1, if your instruments permit this. Record the stack temperatures for each boiler in the appropriate column under the gas title block.

Record the drafts for each boiler in the appropriate spaces in column F. Draft readings are taken at three locations and are expressed in inches of water. Record to 0.01 inch, if the gages permit. If the three locations are not as specified, explain in the Remarks section (item 13).

In column G, enter the feedwater heater

steam pressure and temperature. Obtain the readings from the specified locations (Instructions, fig. 2-39). If no heater is installed, enter a note to this effect in the column.

Feedwater flow and makeup water flow are recorded in columns H and I, respectively. If the plant is equipped with steam flowmeters, it is not mandatory that feedwater meters be installed. The converse is also true. When it is not feasible to make hourly determinations, these quantities may be computed for each shift or each day. Enter a note in the Remarks section to this effect (item 13).

The condensate return temperature should be taken before the condensate enters the condensate receiver or surge tank. Record this information in column J.

Record feedwater pump suction and discharge pressures in column K. This information is used primarily by the plant operator to detect significant changes in the operation of the feedwater system. Sometimes a trend can be detected and the operators can make the necessary adjustments before an emergency condition occurs. If no gages are installed, enter a note in the column to that effect. Record the outside ambient temperature in column L. This temperature is used in computing degree days as explained in figure 2-40, item 5G. Enter the electrical power used (KWH) in column M. If no meter is installed, make an entry in the column to that effect.

At the end of each shift and at the end of the day, compute all totals and averages in columns B through M, as illustrated on figure 2-41.

Operating data. The information classified as operating data is recorded once each shift or three times every 24 hours, as required, on the form. Steam-flow final readings (integrator), steam-flow start readings, and total steam flow are recorded once each 8-hour shift. The start reading is subtracted from the final reading to get the total steam flow. If required, multiply the integrator units by the appropriate correction factor for your meter. These readings are entered on lines A, B, and C of item 5.

Now refer to item 5 of the completed daily log and find the No. 1 boiler on the first shift. The total steam produced is 659 integrator units. In the Remarks section (item 13), the integrator factor is 400. Multiply 659×400 and you get 263,600 pounds of steam. This total is then divided by 1000 and is entered in column C, No. 1 boiler total, for the first shift as 263.6. It is good practice to add the previous 8-hour figures and compare them

with the integrator total for the shift. Your figures for the shift total and the hourly totals should be the same. The remaining boiler totals for each shift are computed in the same manner.

Pounds of steam per unit of fuel for item 5D are computed by dividing the total pounds of steam for the shift by the total gallons of oil. The first figure (527,600 pounds) is obtained by adding the total line for the first shift, column C; the second figure (4,520 gallons) is the total for this shift, column D. This gives us 116.7 pounds of steam per unit of fuel. Each boiler may be computed separately, if desired.

The remaining portion of item 5 is self-explanatory. Figures 2-39 and 2-40 provide detailed instructions.

The combustion efficiency is obtained from a chart for the specified fuel. The average stack temperature and CO₂ percent are computed for all boilers in operation. The room temperature is subtracted from the average stack temperature. The resulting net stack temperature and the CO₂ percent are plotted on the chart, and the combustion efficiency is read at the intersecting points.

Refer to figure 2-41, column E, and find the daily average flue gas temperature for each boiler on the line. The average for all boilers is equal to $582^\circ \text{F.} + 592^\circ \text{F.}$ divided by 2, or 587°F. Noted in item 13 is air temperature of 76°F. Subtracting 76°F. from 587°F. , we have a net stack temperature of 511°F. When we plot the net stack temperature and average CO₂ percent on the combustion efficiency chart for No. 6 oil, we find that our combustion efficiency is 81.9 percent. This is the entry for item 6 on our daily log.

Now, let's take our hypothetical daily log and compute the overall efficiency calculation according to instructions on the back of AF Form 1458, figure 2-40. The methods used to arrive at the solutions in items 7, 8, and 9 are explained in our problem. The boiler, operated at 100 psig, produced 1,482.8 thousand pounds of steam with a feedwater temperature of 221°F. ; 12,860 gallons of No. 6 fuel oil (atomization temperature is 180°F.) were burned at an average of 152,000 Btus per gallon.

First, we must find the enthalpy of steam at 100 psig; 100 psig is approximately 114.6 psia. Now, go to figure 2-43, column p. We find that 114.6 psia is between 114 psia and 116 psia. Reading across at this point in column h_g, we find that the Btu content per pound is between 1189.5 and 1189.8. Approximating the value for 114.6 psia, a

Absolute Pressure Lb. per sq. P	Temp. Fahr. t	Specific Volume Cu. ft. per lb.		Enthalpy or Heat Content BTU per lb.			Entropy		
		Sat. Liquid v _f	Sat. Vapor v _g	Sat. Liquid h _f	Evap. h _{fg}	Sat. Vapor h _g	Sat. Liquid s _f	Evap. s _{fg}	Sat. Vapor s _g
1.0	101.74	0.01614	133.6	69.70	1036.3	1106.0	0.1326	1.8456	1.9782
2.0	126.08	0.01621	173.73	93.99	1022.2	1116.2	0.1749	1.7451	1.9200
3.0	141.48	0.01630	118.71	109.37	1013.2	1122.6	0.2008	1.6855	1.8863
4.0	152.97	0.01636	90.63	120.86	1006.4	1127.3	0.2198	1.6427	1.8625
5.0	162.24	0.01640	73.52	130.13	1001.0	1131.1	0.2347	1.6094	1.8441
6.0	170.06	0.01645	61.98	137.96	996.2	1134.2	0.2472	1.5820	1.8292
7.0	176.85	0.01649	53.64	144.76	992.1	1136.9	0.2581	1.5586	1.8167
8.0	182.86	0.01653	47.34	150.79	988.5	1139.3	0.2674	1.5383	1.8057
9.0	188.28	0.01656	42.40	156.22	985.2	1141.4	0.2759	1.5203	1.7962
10	193.21	0.01659	38.42	161.17	982.1	1143.3	0.2835	1.5041	1.7876
11	197.75	0.01662	35.14	165.73	979.3	1145.0	0.2903	1.4897	1.7800
12	201.96	0.01665	32.40	169.96	976.6	1146.6	0.2967	1.4763	1.7730
13	205.88	0.01667	30.06	173.91	974.2	1148.1	0.3027	1.4638	1.7665
14	209.56	0.01670	28.04	177.61	971.9	1149.5	0.3083	1.4522	1.7605
14.696	212.00	0.01672	26.80	180.07	970.3	1150.4	0.3120	1.4446	1.7566
15	213.03	0.01672	26.29	181.11	969.7	1150.8	0.3135	1.4415	1.7549
16	216.32	0.01674	24.75	184.42	967.6	1152.0	0.3184	1.4313	1.7497
17	219.44	0.01677	23.39	187.56	965.5	1153.1	0.3231	1.4218	1.7449
18	222.41	0.01679	22.17	190.56	963.6	1154.2	0.3275	1.4128	1.7403
19	225.24	0.01681	21.08	193.42	961.9	1155.3	0.3317	1.4043	1.7360
20	227.96	0.01683	20.089	196.16	960.1	1156.3	0.3356	1.3962	1.7319
21	230.57	0.01685	19.192	198.79	958.4	1157.2	0.3395	1.3885	1.7280
22	233.07	0.01687	18.375	201.33	956.8	1158.1	0.3431	1.3811	1.7242
23	235.49	0.01689	17.627	203.78	955.2	1159.0	0.3466	1.3740	1.7206
24	237.82	0.01691	16.938	206.14	953.7	1159.8	0.3500	1.3672	1.7172
25	240.07	0.01692	16.303	208.42	952.1	1160.6	0.3533	1.3606	1.7139
26	242.25	0.01694	15.715	210.62	950.7	1161.3	0.3564	1.3544	1.7108
27	244.36	0.01696	15.170	212.75	949.3	1162.0	0.3594	1.3484	1.7078
28	246.41	0.01698	14.663	214.83	947.9	1162.7	0.3623	1.3425	1.7048
29	248.40	0.01699	14.189	216.86	946.5	1163.4	0.3652	1.3368	1.7020
30	250.33	0.01701	13.746	218.82	945.3	1164.1	0.3680	1.3313	1.6993
31	252.22	0.01702	13.330	220.73	944.0	1164.7	0.3707	1.3260	1.6967
32	254.05	0.01704	12.940	222.59	942.8	1165.4	0.3733	1.3209	1.6941
33	255.84	0.01705	12.572	224.41	941.6	1166.0	0.3758	1.3159	1.6917
34	257.58	0.01707	12.226	226.18	940.3	1166.5	0.3783	1.3110	1.6893
35	259.28	0.01708	11.898	227.91	939.2	1167.1	0.3807	1.3063	1.6870
36	260.95	0.01709	11.588	229.60	938.0	1167.6	0.3831	1.3017	1.6848
37	262.57	0.01711	11.294	231.26	936.9	1168.2	0.3854	1.2972	1.6826
38	264.16	0.01712	11.015	232.89	935.8	1168.7	0.3876	1.2929	1.6805
39	265.72	0.01714	10.750	234.46	934.7	1169.2	0.3898	1.2886	1.6784
40	267.25	0.01715	10.498	236.03	933.7	1169.9	0.3919	1.2844	1.6763
41	268.74	0.01716	10.258	237.55	932.6	1170.2	0.3940	1.2803	1.6743
42	270.21	0.01717	10.029	239.04	931.6	1170.7	0.3960	1.2764	1.6724
43	271.64	0.01719	9.810	240.51	930.6	1171.1	0.3980	1.2726	1.6706
44	273.05	0.01720	9.601	241.95	929.6	1171.6	0.4000	1.2687	1.6687
45	274.44	0.01721	9.401	243.36	928.6	1172.0	0.4019	1.2650	1.6669
46	275.80	0.01722	9.209	244.75	927.7	1172.4	0.4038	1.2613	1.6652
47	277.13	0.01723	9.025	246.12	926.7	1172.9	0.4057	1.2577	1.6634
48	278.45	0.01725	8.848	247.47	925.8	1173.3	0.4075	1.2542	1.6617
49	279.74	0.01726	8.678	248.79	924.9	1173.7	0.4093	1.2508	1.6601
50	281.01	0.01727	8.515	250.09	924.0	1174.1	0.4110	1.2474	1.6585
51	282.26	0.01728	8.359	251.37	923.0	1174.4	0.4127	1.2442	1.6569
52	283.49	0.01729	8.208	252.63	922.2	1174.8	0.4144	1.2409	1.6553
53	284.70	0.01730	8.062	253.87	921.3	1175.2	0.4161	1.2377	1.6538
54	285.90	0.01731	7.922	255.09	920.5	1175.6	0.4177	1.2346	1.6523
55	287.07	0.01732	7.787	256.30	919.6	1175.9	0.4193	1.2316	1.6509
56	288.23	0.01733	7.656	257.50	918.8	1176.3	0.4209	1.2285	1.6494
57	289.37	0.01734	7.529	258.67	917.9	1176.6	0.4225	1.2255	1.6480
58	290.50	0.01736	7.407	259.82	917.1	1176.9	0.4240	1.2226	1.6466
59	291.61	0.01737	7.289	260.96	916.3	1177.3	0.4255	1.2197	1.6452

CG-05C

Figure 2-42. Properties of saturated steam, part 1.



Absolute Pressure Lb P	Temp Fahr t	Specific Volume Cu. ft. per lb.		Enthalpy or Heat Content BTU per lb.			Entropy		
		Sat Liquid	Sat Vapor	Sat Liquid	Evap	Sat Vapor	Sat Liquid	Evap.	Sat Vapor
		v_f	v_g	h_f	h_{fg}	h_g	s_f	s_{fg}	s_g
60	292.71	0.01738	7.175	262.09	915.5	1177.6	0.4270	1.2168	1.6438
61	293.79	0.01739	7.064	263.20	914.7	1177.9	0.4285	1.2140	1.6425
62	294.85	0.01740	6.957	264.30	913.9	1178.2	0.4300	1.2112	1.6412
63	295.90	0.01741	6.853	265.38	913.1	1178.5	0.4314	1.2085	1.6399
64	296.94	0.01742	6.752	266.45	912.3	1178.8	0.4328	1.2059	1.6387
65	297.97	0.01743	6.655	267.50	911.6	1179.1	0.4342	1.2032	1.6374
66	298.99	0.01744	6.560	268.55	910.8	1179.4	0.4356	1.2006	1.6362
67	299.99	0.01745	6.468	269.58	910.1	1179.7	0.4369	1.1981	1.6350
68	300.98	0.01746	6.378	270.60	909.4	1180.0	0.4383	1.1955	1.6338
69	301.96	0.01747	6.291	271.61	908.7	1180.3	0.4396	1.1930	1.6326
70	302.92	0.01748	6.206	272.61	907.9	1180.6	0.4409	1.1906	1.6315
71	303.88	0.01749	6.124	273.60	907.2	1180.8	0.4422	1.1881	1.6303
72	304.83	0.01750	6.044	274.57	906.5	1181.1	0.4435	1.1857	1.6292
73	305.76	0.01751	5.966	275.54	905.8	1181.3	0.4447	1.1834	1.6281
74	306.68	0.01752	5.890	276.49	905.1	1181.6	0.4460	1.1810	1.6270
75	307.60	0.01753	5.816	277.43	904.5	1181.9	0.4472	1.1787	1.6259
76	308.50	0.01754	5.743	278.37	903.7	1182.1	0.4484	1.1764	1.6248
77	309.40	0.01754	5.673	279.30	903.1	1182.4	0.4496	1.1742	1.6238
78	310.29	0.01755	5.604	280.21	902.4	1182.6	0.4508	1.1720	1.6228
79	311.16	0.01756	5.537	281.12	901.7	1182.8	0.4520	1.1698	1.6217
80	312.03	0.01757	5.472	282.02	901.1	1183.1	0.4531	1.1676	1.6207
81	312.89	0.01758	5.408	282.91	900.4	1183.3	0.4543	1.1654	1.6197
82	313.74	0.01759	5.346	283.79	899.7	1183.5	0.4554	1.1633	1.6187
83	314.59	0.01760	5.285	284.66	899.1	1183.8	0.4565	1.1612	1.6177
84	315.42	0.01761	5.226	285.53	898.5	1184.0	0.4576	1.1592	1.6168
85	316.25	0.01761	5.168	286.39	897.8	1184.2	0.4587	1.1571	1.6158
86	317.07	0.01762	5.111	287.24	897.2	1184.4	0.4598	1.1551	1.6149
87	317.88	0.01762	5.055	288.08	896.5	1184.6	0.4609	1.1530	1.6139
88	318.68	0.01764	5.001	288.91	895.9	1184.8	0.4620	1.1510	1.6130
89	319.48	0.01765	4.948	289.74	895.3	1185.1	0.4630	1.1491	1.6121
90	320.27	0.01766	4.896	290.56	894.7	1185.3	0.4641	1.1471	1.6112
91	321.06	0.01767	4.845	291.38	894.1	1185.5	0.4651	1.1452	1.6103
92	321.83	0.01768	4.796	292.18	893.5	1185.7	0.4661	1.1433	1.6094
93	322.60	0.01768	4.747	292.98	892.9	1185.9	0.4672	1.1413	1.6085
94	323.36	0.01769	4.699	293.78	892.3	1186.1	0.4682	1.1394	1.6076
95	324.12	0.01770	4.652	294.56	891.7	1186.2	0.4692	1.1376	1.6068
96	324.87	0.01771	4.606	295.34	891.1	1186.4	0.4702	1.1358	1.6060
97	325.61	0.01772	4.561	296.12	890.5	1186.6	0.4711	1.1340	1.6051
98	326.35	0.01772	4.517	296.89	889.9	1186.8	0.4721	1.1322	1.6043
99	327.08	0.01773	4.474	297.65	889.4	1187.0	0.4731	1.1304	1.6035
100	327.81	0.01774	4.432	298.40	888.8	1187.2	0.4740	1.1286	1.6026
102	329.25	0.01775	4.350	299.90	887.6	1187.5	0.4759	1.1251	1.6010
104	330.66	0.01777	4.271	301.37	886.5	1187.9	0.4778	1.1216	1.5994
106	332.05	0.01778	4.194	302.82	885.4	1188.2	0.4796	1.1182	1.5978
108	333.42	0.01780	4.120	304.26	884.3	1188.6	0.4814	1.1149	1.5963
110	334.77	0.01782	4.049	305.66	883.2	1188.9	0.4832	1.1117	1.5948
112	336.11	0.01783	3.981	307.06	882.1	1189.2	0.4849	1.1085	1.5934
114	337.42	0.01784	3.914	308.43	881.1	1189.5	0.4866	1.1053	1.5919
116	338.72	0.01786	3.850	309.79	880.0	1189.8	0.4883	1.1022	1.5905
118	339.99	0.01787	3.788	311.12	879.0	1190.1	0.4900	1.0992	1.5891
120	341.25	0.01789	3.728	312.44	877.9	1190.4	0.4916	1.0962	1.5878
122	342.50	0.01791	3.670	313.75	876.9	1190.7	0.4932	1.0933	1.5865
124	343.72	0.01792	3.614	315.04	875.9	1190.9	0.4948	1.0903	1.5851
126	344.94	0.01793	3.560	316.31	874.9	1191.2	0.4964	1.0874	1.5838
128	346.13	0.01794	3.507	317.57	873.9	1191.5	0.4980	1.0845	1.5825
130	347.32	0.01796	3.455	318.81	872.9	1191.7	0.4995	1.0817	1.5812
132	348.48	0.01797	3.405	320.04	872.0	1192.0	0.5010	1.0790	1.5800
134	349.64	0.01799	3.357	321.25	871.0	1192.2	0.5025	1.0762	1.5787
136	350.78	0.01800	3.310	322.45	870.1	1192.5	0.5040	1.0735	1.5775
138	351.91	0.01801	3.264	323.64	869.1	1192.7	0.5054	1.0709	1.5763

C.G. 251

Figure 2-43. Properties of saturated steam, part 2.



Temp	Volume	Temp	Volume	Temp	Volume	Temp	Volume	Temp	Volume	Temp	Volume
0	1.0211	36	1.0084	72	0.9958	108	0.9834	144	0.9711	180	0.9590
2	1.0204	38	1.0077	74	0.9952	110	0.9827	146	0.9704	182	0.9583
4	1.0197	40	1.0070	76	0.9944	112	0.9820	148	0.9697	184	0.9576
6	1.0190	42	1.0063	78	0.9938	114	0.9813	150	0.9691	186	0.9569
8	1.0183	44	1.0056	80	0.9931	116	0.9806	152	0.9684	188	0.9563
10	1.0176	46	1.0049	82	0.9924	118	0.9799	154	0.9677	190	0.9556
12	1.0168	48	1.0042	84	0.9917	120	0.9792	156	0.9670	192	0.9549
14	1.0161	50	1.0035	86	0.9910	122	0.9785	158	0.9664	194	0.9543
16	1.0154	52	1.0028	88	0.9903	124	0.9779	160	0.9657	196	0.9536
18	1.0147	54	1.0021	90	0.9896	126	0.9772	162	0.9650	198	0.9530
20	1.0141	56	1.0014	92	0.9889	128	0.9765	164	0.9643	200	0.9523
22	1.0134	58	1.0007	94	0.9882	130	0.9758	166	0.9637	202	0.9517
24	1.0126	60	1.0000	96	0.9876	132	0.9751	168	0.9630	204	0.9510
26	1.0119	62	0.9993	98	0.9869	134	0.9745	170	0.9623	206	0.9504
28	1.0112	64	0.9986	100	0.9862	136	0.9738	172	0.9616	208	0.9497
30	1.0106	66	0.9979	102	0.9855	138	0.9731	174	0.9610	210	0.9490
32	1.0098	68	0.9972	104	0.9848	140	0.9724	176	0.9603	212	0.9484
34	1.0092	70	0.9965	106	0.9841	142	0.9718	178	0.9596	214	0.9477

CG-065

Figure 2-44. Volume of oil as varied by temperature.

pound of steam will contain 1189.6 Btus per pound. This is the enthalpy of steam at 100 psig.

Now we must find the enthalpy of the feedwater at 221° F. Refer to figure 2-42 and look under column t for 221° F. We find that 221° F. is between 219.44° F. and 222.41° F. Reading across this point in column h_l, we find that the Btus per pound of water is between 187.56 and 190.56. Approximating the value of 221° F., a pound of water will contain 189.6 Btus per pound. This is the enthalpy of the feedwater at 221° F.

Subtract the enthalpy of feedwater from the enthalpy of steam and multiply by the pounds of steam produced. We now have figures that look like this: (1189.6 - 189.6) × 1,482,800; or 1000.0 × 1,482,800 equals 1,482,800,000 Btus. Divide 1,482,800,000 by 1,000,000 and we have 1,482.8 million Btu output. This is item 7.

To find the input Btu, we multiply the quantity of fuel burned by the calorific value of the fuel. To obtain the Btu input, it is essential to know the exact amount of fuel burned. As the fuel passes to the burners, it is recorded by a volumetric meter. Because of expansion, the amount of oil recorded must be referenced to 60° F. where specific gravity and degrees API (American Petroleum Institute) are determined. This is accomplished because each degree rise in Fahrenheit temperature will expand 1 gallon of oil .00034 gallon. This shows up as a higher consumption of oil when recorded by the

volumetric meter. The process of referencing the oil to 60° F. will give the actual number of gallons used and an accurate Btu content for computation. One method of referencing the oil is by subtracting 60° F. from whatever temperature the oil is raised to (180° F. in our example). Multiply the expansion factor (.00034) by the difference in oil temperature to get the total expansion for 1 gallon of oil. Multiply the oil recorded through the meter by the total expansion for 1 gallon. Subtract the computed expansion compensation figure from the recorded oil figure and this will be the actual gallons consumed for efficiency computation. An easier, alternate method of referencing is to use information obtained from the United States Department of Commerce, National Bureau of Standards, Circular C-410, as shown in figure 2-44. This is a chart that shows the volume of oil at various temperatures. When using this chart to obtain actual gallons consumed, multiply the recorded gallons of oil by the percentage on the chart that coincides with the average temperature of the oil. If we start with 12,860 gallons of oil at 180° F. and compensate for expansion by using figure 2-44, we have a total of 12,333 gallons used (12,860 × .9590). Multiply this figure by the Btu content per unit (152,000 Btus) which will be 1,874,616,000 Btus. Divide 1,874,616,000 by 1,000,000 and we have 1,874.6 million Btu for the input to be entered as item 8. Divide the Btu output by the Btu input or divide 1,482.8 by 1,874.6. This is equal to 0.790. Now multiply by .30

423

AF Form 1464 is for use by all installations operating steam boiler plants having capacities greater than 1,680,000 Btu/hr for low operating pressures (15 psi maximum) and 1,400,000 Btu/hr for operating pressures over 15 psi. Each time an operator makes a visit to a heating plant which is not constantly attended, in accordance with the frequency of operational visits noted in AFM 85-12, he will enter the appropriate information obtainable from the existing permanently installed instrumentation on AF Form 1458. Each operating shift at constantly attended steam plants will fill out AF Form 1458. Post the information from AF Form 1458, ~~Daily Steam Boiler Plant Operating Log~~, daily on AF Form 1464. Where there is more than one plant, each separate plant uses a separate AF Form 1464. Some of the instrumentation from which data for this log is obtained is described in AFM 88-15 and AFM 85-12. AF Form 1464 will be prepared in duplicate by the person having charge of the operation of the boilers and will be posted daily at the plant.

Column A. In pounds per square inch gage, the average of the steam pressure carried during the day on all boilers.

Column B. In units of 1,000 lbs., the steam produced by each boiler and the total for all boilers.

Column C. Compute by dividing the rate of steam flow for the one hour period having the largest output by the sum of the design pounds per hour steam flow rating at the working temperature and pressure of all the boilers in operation contributing to the steam flow and multiply by 100.

$$\text{Percent} = \frac{\text{Highest Total Hourly Output}}{\text{Design Output of Operating Boilers (item 9)}} \times 100$$

Column D. Check applicable fuel used. The total amount of each fuel consumed each day for each boiler and the total for all boilers. Gas figures will be taken from meters, oil figures from meters or tank gaging and coal from actual weighings or estimated usage.

Column E. The average CO₂ in the flue gas from each boiler and the temperature in degrees F. These temperatures will be taken at the point immediately after gases have passed the last heating surface in each boiler. (The readings of CO₂ and stack or flue gas temperatures must be accurate. Check instruments frequently.)

Column F. The daily average pressure taken from the shell of the heater in pounds per square inch gage. The temperature in degrees F. of the feedwater, taken immediately after water passes over the trays or sprays, at the highest water level.

Column G. The total number of gallons of feedwater to all boilers.

Column H. The daily metered gallons of makeup water required.

Column I. Compute by dividing the pounds of makeup water by the pounds of steam flow or feedwater flow and multiply by 100. Allow 8.3 pounds per gallon to determine the weight of water.

Column J. The average daily temperature of condensate returned to the surge tank or pump receiver.

Column K. The maximum and minimum outside ambient temperature.

Column L. Degree days are computed by adding the maximum and minimum temperatures during the 24-hour period, divided by 2 and subtracting this from 65° F. (Negative results will not be entered.)

Column M. From applicable efficiency charts in Vol 1, AFM 85-12, for the fuel used, based on CO₂ readings and stack temperatures, obtain combustion efficiency for each boiler. Calculate the average efficiency by adding all boiler efficiencies and dividing by the number of operating boilers. When more than one fuel is used, indicate efficiencies for each fuel.

Column N. Compute by dividing plant output in Btu (Item 6A) by plant input in Btu (Item 6B), and multiplying by 100.

$$\frac{\text{Total BTU Output (Item 6A)}}{\text{Total BTU Input (Item 6B)}} \times 100$$

BE-1464B

Figure 2-45. AF Form 1464 instructions, part 1.



Column O. Kilowatt hours used during the day for the entire plant, if metered.

Column P. The man-hours used for operation of the plant excluding administrative time and outside system maintenance.

Item 5: (Btu/lb for coal, Btu/gal for oil and Btu/MCF for gas.) These figures will be obtained from fuel contracts or, when currently obtainable, analysis reports.

Item 6A. Multiply the total steam produced in pounds for each boiler, column B, by the enthalpy of the steam at the average operating steam pressure and temperature minus the enthalpy of the feedwater at the average feedwater temperature, column F, from steam tables and divide by one million. (Steam tables available in AFM 88-54.) Add output for all boilers to obtain total.

$$\frac{\text{Total Steam Produced per Boiler (Col B) X} \\ \text{(Enthalpy of Steam - Enthalpy of Feedwater)}}{1,000,000}$$

Item 6B. Multiply the total quantity of fuel used for the month for each boiler, column D, by the unit calorific value of the fuel, Item 5, and divide by one million. Add values for all boilers to obtain TOTAL.

$$\frac{\text{Total Fuel Used per Boiler (Col D) X Calorific Value of Fuel (Col Q)}}{1,000,000}$$

Item 7. Obtain combustion efficiency for each boiler from applicable efficiency charts in Vol I, AFM 85-12, for the fuel used based on average monthly CO₂ values and average monthly stack temperatures. When more than one fuel is used, indicate efficiency for each fuel. Compute boiler overall efficiency by dividing monthly Btu output for each boiler, Item 6A, by monthly Btu input for each boiler, Item 6B, and multiplying by 100.

$$\frac{\text{Monthly BTU Output (Item 6A)}}{\text{Monthly BTU Input (Column 6B)}} \times 100$$

Item 8. Use for changes or unusual occurrences in the performance of the plant. Explain why any of the columns cannot be filled in, i. e., no instrumentation or instrumentation inoperable, etc. Continue remarks on the reverse of the form if additional space is required.

Item 9. On reverse of form annotate only in January of each year and when equipment change is made.

A. Permanent number assigned to each boiler shall be used consistently.

B. Enter the name of the manufacturer of each boiler.

C. Enter model number and type of each boiler such as straight water tube boiler or HRT boiler.

D. Enter design rating of each boiler giving rating units as pounds of steam per hour at the working temperature and pressure.

E. Enter the make and model number for each boiler and type such as underfeed stoker, rotary cup oil burner, high pressure gas burner.

F. For example: hand, bin or bunker.

G. For example: stationary, traveling chain, or dump. Signature of the chief operating engineer indicates his approval of the plant operation, unless his comments in the remarks column indicate otherwise. At the end of the month he forwards both copies of AF Form 1464 to the base civil engineer for review and approval. After approval, the base civil engineer retains the original and forwards the second copy to the major command on or before the 20th of the following month.

BE-1464C

Figure 2-46. AF Form 1464 instructions, part 2.

to convert to percent and we have 79.0 percent. This is our overall efficiency and item 9 on our log.

The peak demand factor (item 10) is equal to the highest total output (column C) divided by the design output rating of the boilers in operation in pph (pounds per hour) multiplied by 100. Each of our boilers used in the plant illustrated in figure 2-41 has a design output of 33,500 pph, or a total of 67,000 pph. The highest total output for any 1 hour occurred at 0500, 0600, 0700, and 0800. This total was 66,800 pph. Dividing 66,800 by 67,000 and multiplying by 100, we have a peak demand factor of 99.7 percent.

Item 11 is computed by dividing the total pounds of makeup water by the total pounds of steam produced and multiplying by 100. In our example, we have 17,700 gallons of water at 8.3 pounds per gallon, or 146,910 pounds of water. Divide 146,910 pounds of water by 1,482,800 (item 7) pounds of steam and multiply by 100. This gives us 9.9 percent makeup.

The total fuel used is compiled from the daily totals for each boiler. In our illustration, this would be 6,500 gallons plus 6,360 gallons (column D). Therefore, our total for item 12 would be 12,860 metered gallons.

Monthly Operating Log. Monthly data is recorded on the Monthly Steam Boiler Plant Operating Log, AF Form 1464, which is shown in figure 2-47. The instructions for completing this form correctly are printed on the reverse outside of the form. In this volume, they appear as figures 2-45 and 2-46. Carefully read these instructions while you look at the form, then return to the following discussion.

Now look at the 17th day of the monthly log and compare these entries with the final computations we made on the daily log. You will note that all daily entries on the monthly log have been previously computed and entered on the daily log. All that we have to do is transfer the daily information to the monthly log. If individual boiler output is not metered, enter a checkmark in column B to indicate which boilers were operating, and enter the total plant output in the Total column. The same procedures apply to column D if each boiler is not metered.

At the end of the month, total all columns as indicated and compute the averages. Identify the maximum and minimum values and enter them in the space provided. Items 1 through 5 are self-explanatory.

The monthly Btu output (item 6A) is computed in the same manner that we computed the daily output. The only

425
difference is that we use the monthly total for the steam produced and the average monthly feedwater temperature. The monthly Btu input (item 6B) is computed by multiplying the total units of fuel used by the calorific value of the fuel and dividing by 1,000,000.

Item 7, overall efficiency, is computed by dividing the monthly output (item 6A) by the monthly input (item 6B) and multiplying by 100. Combustion efficiency is computed in the same manner that we computed combustion efficiency on the daily log. Use the monthly flue gas and temperature averages. Item 8 is self-explanatory.

Exercises (644):

1. Where should you look for instructions for completing the daily and monthly logs?
2. How often are entries made on the daily operating log?
3. How is the amount of fuel used recorded on the daily log?
4. Draft readings entered on the daily log are taken at how many points?
5. What must you do when it is not feasible to make all entries called for on a log?
6. Why do you record the outside ambient temperature on the daily log?
7. A steamplant produced 608,000 pounds of steam at 100 psig, with a feedwater temperature of 221° F., and burned 5000 actual gallons of number six oil at 152,000 Btus per gallon. What is the overall efficiency?
8. A plant used 8100 gallons of makeup water and produced 600,000 pounds of steam. What is the percent of makeup?

426

MONTHLY STEAM BOILER PLANT OPERATING LOG										1. COMMAND HQ COMMAND (USAF)		2. BASE	
DATE	AVERAGE STEAM PRESS (PSIG)	B. STEAM PRODUCED (1000 LBS)				PEAK DEMAND FACTOR (%)	D. FUEL USED				C		
		BOILER NO.					TOTAL	BOILER NO.				TOTAL	
		1	2	3	4			1	2	3			4
1	100	641.2		650.8	1292.0	89.0	5630		5640	11,270	11.8		
2	100	653.6		641.2	1296.8	90.0	5760		5480	11,240	11.7		
3	101	720.0		710.0	1430.0	89.1	6290		6230	12,520	12.1		
4	100	710.4		680.4	139.8	88.1	6210		5930	12,160	12.2		
5	100	712.6		691.4	1404.0	87.0	6240		5980	12,220	12.4		
6	99	680.0		670.2	1350.2	85.1	5970		5880	11,850	12.0		
7	100	726.2		700.0	1426.2	88.6	6350		6190	12,540	11.8		
8	100	640.8		610.2	1251.0	90.6	5630		5360	11,010	12.0		
9	101	712.0		691.8	1403.8	95.5	6250		6080	13,330	11.8		
10	100	716.8		690.0	1406.8	96.5	6290		5950	13,240	12.1		
11	100	700.0		681.2	1381.2	98.1	6160		5900	12,060	12.1		
12	100	640.0		600.0	1240.0	99.0	5640		5280	11,920	12.0		
13	100	646.8		618.2	1265.0	99.0	5690		5420	11,110	11.8		
14	100	645.2		620.0	1265.2	99.1	5730		5450	11,140	11.7		
15	100	650.8		620.2	1271.0	99.1	5690		5230	10,960	12.1		
16	99	648.0		626.8	1274.8	98.1	5710		5350	11,060	12.2		
17	100	743.2		739.6	1482.8	99.7	6500		6360	12,860	12.1		
18	100	650.0		625.2	1275.2	99.6	5670		5550	11,220	11.8		
19	100	641.8		620.8	1262.6	99.1	5590		5400	10,990	12.1		
20	101	643.2		640.0	1283.2	99.6	5610		5330	11,140	12.1		
21	101	640.2		651.2	1291.4	96.1	5760		5580	11,240	12.0		
22	100	650.8		650.0	1300.8	90.1	5660		5770	11,430	11.9		
23	100	674.6		671.8	1346.4	93.1	5890		5840	11,730	11.8		
24	100	690.4		680.2	1370.6	90.1	6120		5980	12,100	11.9		
25	99	551.6		560.6	1112.2	87.6	4980		4880	9,860	12.0		
26	100	540.2		551.8	1092.0	86.1	4840		4740	9,540	12.1		
27	100	590.8		586.2	1177.0	87.1	5260		4970	10,230	12.2		
28	100	645.6		651.6	1297.2	87.0	5520		5630	11,150	12.3		
29	99	649.2		656.8	1306.0	90.0	5770		5780	11,550	11.9		
30	100	743.2		753.6	1496.8	99.1	6400		6580	12,980	12.0		
31	100	765.4		760.4	1525.8	99.9	6600		6550	13,230	12.1		
TOTAL		29666.6		29301.4	40,968.0		181,510		176,510	358,020			
MAX.	101	765.4		760.4	1525.8	99.9	6600		6580	13,230	12.4		
MIN.	99	540.2		551.8	1092.0	85.1	4840		4740	9,540	11.7		
AVG.	100	666.7		654.9	1321.6	93.3	5855		5371	11,549	12.0		

5. CALORIFIC VALUE OF FUEL USED			6. BOILER NO.	
A. COAL (Average BTU/Lb)	B. OIL (Average BTU/Gal)	C. GAS (Average BTU/MCF)	1	
	152,000			
			MONTHLY BTU OUTPUT (Millions)	
			29,666.6	
			MONTHLY BTU INPUT (Millions)	
			26,458.3	

6. REMARKS (Continue on reverse)

ITEM 8 - NOT REQUIRED
 ITEM 9 - NO METER INSTALLED
 AVERAGE ROOM TEMPERATURE - 70°F
 MONTHLY BTU INPUT AND OVERALL EFFICIENCY COMPUTATION IS BASED ON OIL FIGURE REFERENCED TO 60°F IN ACCORDANCE WITH U.S. DEPARTMENT OF COMMERCE, NATIONAL BUREAU OF STANDARDS, CIRCULAR C-410

DATE: 1 FEB. 74

SIGNATURE OF CHIEF OPERATING ENGINEER: *Walter Dennis C. Christensen*

AF FORM 1464 SEP 66 PREVIOUS EDITION OF THIS FORM WILL BE USED UNTIL STOCK IS EXHAUSTED.

Figure 2-47. AF Form 1464, front side.

9. How is the monthly Btu input computed?
 10. How is the monthly overall efficiency computed?



427

1. ADD. LOCATION ANDREWS AFB MD (WASHINGTON D.C. 2023)				3. BUILDING NO. AND NAME #1732 WEST FLIGHT LINE PLANT				4. DATE JAN. 74								
E. FLUE GAS				FEEDWATER HEATER		FEEDWATER FLOW G (Gallons)	MAKEUP WATER FLOW (Gallons)	COND. WATER (G)	COND. RETURNED TEMP. °F	OUTSIDE TEMP (°F)		DEGREE DAYS	PLANT COMBUSTION EFFICIENCY	PLANT OVERALL EFFICIENCY	ELECTRIC POWER USED (KWH)	TOTAL MANHOURS OPERATION
2 (Avg. %)		TEMP (Avg °F)		AVERAGE PRESS (PSIG)	AVERAGE TEMP. °F					MAX	MIN					
BOILER NO.		BOILER NO.														
1	2	3	4	5	6	7	8	9	10	11	12	13	14	15	16	
121	590	590		3.5	221	17400	11.2	178	45	25	30.5	81.3	78.6		72	
120	595	586		3.4	220	17800	11.4	178	40	24	33.0	81.2	78.3		64	
12.1	580	591		3.4	221	17200	10.0	178	35	20	37.5	81.4	78.0		56	
119	579	590		3.5	221	19900	11.9	179	40	20	35.0	81.4	78.1		48	
12.0	585	585		3.6	222	20200	12.1	179	42	17	35.5	81.6	78.5		48	
12.0	585	585		3.5	221	21300	13.1	180	44	22	32.0	81.5	78.0		48	
119	590	590		3.6	221	20600	12.0	180	40	25	33.5	81.2	77.6		48	
12.1	580	585		3.5	221	17300	11.5	181	46	24	30.0	81.6	78.5		72	
12.2	590	580		3.5	221	20400	12.0	181	40	20	35.0	81.5	78.5		64	
12.3	585	575		3.6	222	19600	11.6	180	38	18	37.0	81.8	78.9		56	
1.9	585	595		3.6	221	19100	11.5	181	40	20	35.0	81.7	78.8		48	
11.8	585	600		3.5	221	16400	11.0	180	46	25	32.5	81.2	78.0		48	
11.9	590	595		3.5	221	19500	12.8	179	46	26	31.0	81.2	78.1		48	
12.0	595	585		3.5	221	20600	13.5	181	40	25	32.5	81.2	78.0		48	
12.1	580	590		3.4	220	15300	10.1	180	41	27	31.0	81.6	79.6		64	
12.0	578	590		3.5	221	15400	10.8	181	46	30	27.0	81.8	79.1		48	
12.0	582	592		3.5	220	17700	9.9	179	32	17	40.5	81.9	79.8		48	
12.1	591	590		3.5	221	15200	9.8	179	36	30	32.0	81.4	78.0		48	
12.0	581	591		3.6	221	15400	10.1	180	41	31	29.0	81.6	78.8		48	
11.9	580	595		3.5	221	18300	11.9	180	46	25	29.5	81.6	79.0		48	
11.8	578	595		3.5	221	18700	12.0	181	45	25	30.0	81.4	78.1		72	
11.9	586	600		3.5	221	19600	12.5	181	44	20	33.0	81.2	78.0		64	
12.1	590	590		3.4	220	20800	12.8	179	41	20	34.5	81.4	78.5		56	
12.0	595	595		3.5	221	21500	13.6	179	40	19	35.5	81.2	77.5		48	
12.0	585	595		3.6	222	14700	11.0	180	48	28	27.0	81.4	77.8		48	
12.1	581	590		3.5	221	15900	12.1	180	46	31	26.5	81.6	78.9		48	
12.2	576	585		3.5	221	14200	10.0	181	48	30	29.0	81.8	79.8		48	
11.9	570	590		3.5	221	15300	9.8	179	40	30	30.0	81.8	79.7		72	
11.8	585	600		3.4	221	15400	9.8	180	38	31	30.5	81.2	77.4		64	
11.9	580	605		3.5	221	17800	9.9	180	35	14	40.5	81.3	77.5		56	
12.0	578	590		3.6	222	20400	11.1	180	30	11	44.5	81.6	76.1		48	
						537,100					1023.0				1696	
12.3	595	605		3.6	222	21500	13.5	181	48	31	44.5	81.9	79.8		72	
11.8	570	575		3.4	220	14200	9.8	178	30	11	26.5	81.2	77.4		48	
12.0	585	590		3.5	221	18036	11.6	180	41	24	33.0	81.5	78.4		54.0	
2		3		4		TOTAL		7. BOILER EFFICIENCY (%)		BOILER						
		20,301.4				40,968.0		COMBUSTION		81.5				81.4		
		25,744.7				52,203.0		OVERALL		78.2				78.9		
METERED GALLONS: (#1-18,510) (#2-176,510) REFERENCED GALLONS: (#1-174,060) (#2-169,373)																
DATE 5 FEB 74				SIGNATURE OF BASE CIVIL ENGINEER <i>Col Frank Manley</i>												

Figure 2-47 (Contd).



428

645. Specify the purpose of maintaining HTW systems operating logs.

High Temperature Water (HTW) Operating Logs. Monthly High Temperature Water Distribution System Operating Log, AF Form 1163, is used for recording data pertaining to high temperature water distribution systems, system water conditions, and treatment of the water. It is prepared in duplicate in accordance with the instructions on the reverse of the form and is processed in accordance with AFM 85-12.

Monthly High Temperature Water Plant Operating Log, AF Form 1165, is used by all installations that have a high temperature

water heating plant. Data recorded on this log are taken from a daily operating log of local design. Complete the form in accordance with the instructions on the reverse and process it as instructed in AFM 85-12.

Exercises (645):

1. Which operating logs are used with high temperature water?
2. Specify the purpose of maintaining monthly high temperature water systems operating logs.

Steamplant Maintenance

IN CHAPTER 2 of this volume, we described the types and explained the operational features of steam heating equipment and systems. Now we come to another important subject—that of maintenance. Proper maintenance of each system or piece of equipment is important because of the interdependence of all systems and equipment in the overall mission of heating. Maintenance of steamplants takes on an additional importance when you consider the extreme safety hazards involved. Since steam is a vaporous, high-energy state of water, capable of tremendous explosive force, the results of a poorly kept steamplant could be devastating.

3-1. Waterside Maintenance

Boiler watersides must be kept clean and free of scale, oil, sediment, and other foreign matter. Failure to keep the watersides clean can have disastrous results. The great majority of tube failures are caused by waterside deposits or accumulations. Some tube failures are caused by waterside deposits of hard scale. More often, however, tube failure occurs as the result of the accumulation of relatively soft materials.

646. Specify the main procedures for removing and draining a boiler in a steam heating system.

Removing and Draining Boiler. Boilers should be removed from service periodically when their output is no longer needed to meet demand or when extensive repairs are made. Care in handling boilers to prevent quick temperature changes and resulting expansion strains decreases the possibility of forced outages and reduces maintenance costs.

When taking a boiler out of service, stop the fuel supply. This is done in different ways depending on the type of firing used. In coal burning systems, the hoppers or mills should

be emptied as much as possible. When fuel oil or gas is burned, the fuel can be completely shut off.

As the fire burns down or is extinguished, steam pressure in the boiler drops below pressure in the header. If the boiler is equipped with a nonreturn valve, it closes automatically. Close the header and feedwater valves. Screw down on the stem of the nonreturn valve. If two hand-operated header valves are used, close both and open the drain between them when the boiler stops steaming.

Normally, a boiler should be cooled slowly; but if it must be repaired and returned to service in the shortest possible time, resort to forced cooling. This is done by circulating air through the setting either by natural draft or by operating an induced-draft fan. Do not resort to this practice unless it is absolutely necessary, as brick settings may crack and leaks may develop in the pressure section of the boiler. Exercise care when circulating cool air with an induced-draft fan that is designed to handle hot gases, since the load on the fan-driving motor is increased and may overheat. Avoid this danger by adjusting the damper to restrict the flow. When pressure is off the boiler, open the drum vent to prevent formation of a vacuum.

Drain the boiler when it is cool enough so that the furnace can be entered. This precaution prevents baking of scale on the inside of tubes and safeguards against leakage at seams or expanded joints. Open the blowoff valves and allow the boiler to drain. When the boiler to be emptied is set in a battery of two or more boilers, make sure that blowoff valves are opened only on the boiler to be emptied. As soon as the boiler is emptied, close blowoff valves, remove manhole plates and, when necessary, covers of other openings.

Exercises (646):

1. What is the first step in taking a boiler out of service?

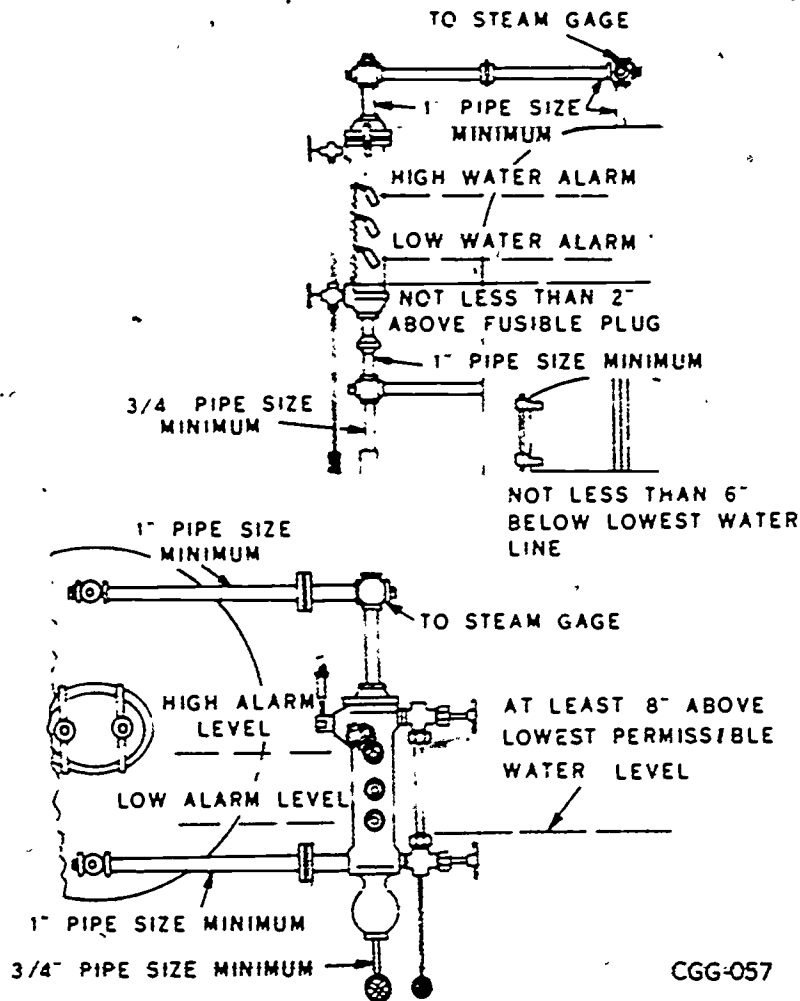


Figure 3-1. Water column connections.

- 2. If there is no time limit on a boiler being out of service, how should it be cooled?
- 3. When should a steam boiler be allowed to drain?
- 4. Why do you open the vent of a steam boiler as soon as the pressure gage indicates no pressure?
- 5. How is the boiler drained?

647. State maintenance fundamentals in removing, cleaning, and replacing water columns and gage glasses.

Maintenance of Water Columns and Gage Glasses. Normally, water columns and gage glasses are connected to the boiler or steam drum with ties and unions or flanges. See figure 3-1. These ties permit easy cleaning of lines, glasses, etc., during normal shutdown. During a boiler overhaul, however, the water columns should be completely disconnected and inspected. By loosening the unions or flanges, the complete water column can be removed. Inspect for any damage, pitting, or worn parts. Repair or replace, as necessary.

Gage glasses can normally be cleaned or replaced without a major boiler shutdown. The gage glass is connected to the water column or boiler by special valved fittings,

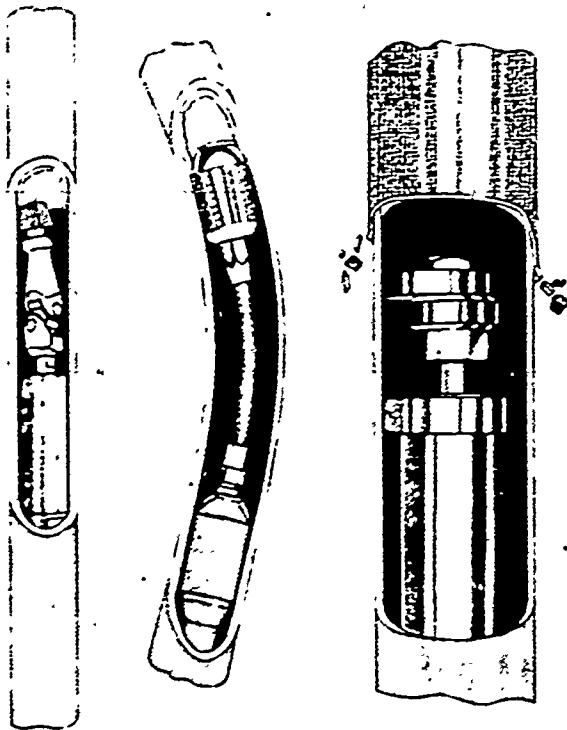


Figure 3-2. Tube cleaners

with the lower fitting provided with a drain valve of the straightway type with openings to facilitate cleaning.

When a water glass has broken, remove the broken pieces and slowly open the valves to blow out any remaining pieces. Before inserting the new glass, see that the drain is open and that the connections are in line. Insert the glass with packing and set up the stuffing box nuts, taking care not to set them up too tightly; then warm the glass by opening the top valve slightly and let a small amount of steam flow through the glass. Close the drain cock after the glass is sufficiently warmed, open the bottom valve slightly; and when the level of the water in the glass has become stable, open the bottom valve wide and then open the top valve wide. This usually completes the operation. When gage valves and water glasses are in need of repair due to leaks, always use the packing rings and washers recommended by the manufacturer. When installing new packing, add graphite to the packing washer to prevent the glass from twisting when the nut is tightened. Insure the packing is secure in the water glass stuffing boxes.

Exercises (647):

1. What process removes the water column from the boiler?

2. What is the normal procedure for putting a gage glass back in service?
3. To insure all broken glass is removed from connections, a proper method is to _____.
4. By what process are water columns and gage glasses usually cleaned without complete removal from boiler?

648. Describe the process of inspecting and cleaning the waterside of a boiler.

Inspecting and Cleaning Waterside. After the boiler has been drained, cooled, and sufficiently prepared for inspection, proceed with the following. Enter the boiler using low voltage portable lamps, provided with suitable guards. Even 110 volts can be lethal under the low resistance conditions found inside a boiler. Therefore, all portable electrical equipment must be grounded and adequately insulated. Use extension cords that are designed for rough usage; keep them in good condition. Look for signs of scale, oil, corrosion, abnormal wear, and abrasion of pressure parts. Check the condition of drum internals, feed connections, safety valves, drains, blowdown connections, etc. Check connections to water column, gage glass, and steam pressure gage. Check tube ends for corrosion and leakage. When the inspection is completed and all discrepancies have been noted, you should clean the boiler.

Whenever a boiler is removed from service, no matter what reason, it should be internally cleaned before being put back in service, or placed in storage. Loose material in the form of dirt, trash, scale, or deposits should be removed by washing. Boiler deposits not readily removable by simple washing may be removed by mechanical cleaning or chemical cleaning.

Mechanical. Different types of mechanical cleaners have been developed. In general, they consist of a motor-driven, flexible shaft, with a rotor, brush, or expanding cleaner. The motor, actuated by air, water, or electric power, drives revolving brushes, cutters, or other heads through the tubes to dislodge scale or other deposits. Figure 3-2 illustrates different types of tube cleaners. Move the cleaner at a uniform rate and never operate it continuously in the same position, or the

inner surface of the tube may be ground away. With a water hose, wash down the loosened deposits to the lower clean-out points of the boiler and remove them. Thoroughly clean mud drums, steam drums, and headers.

Chemical. Tubes can be cleaned by chemical methods. Acid cleaning is very effective if a reliable, controlled procedure is used. Acid cleaning is conducted with an inhibited acid solution primarily for the purpose of removing scale and corrosion. Because of the chemical control required and the hazards involved through the improper use of acids in destroying both ferrous and nonferrous metals, and in causing the production of explosive gases, work of this kind should be supervised by personnel specially qualified by training and experience in this highly technical field.

Exercises (648):

1. List the discrepancies to look for in inspecting the pressure parts of a boiler.
2. Describe the process of inspecting the watersides of a boiler.
3. What are the methods of cleaning the boiler internally?
4. When should you clean the boiler internally?
5. How is a boiler tube cleaned mechanically?
6. Explain how a mechanical cleaner is used.
7. What is one exception levied on the use of acid cleaning?

649. Cite inspection and replacement requirements of fusible plugs.

Inspection and Maintenance of Fusible Plugs. The types and purposes of fusible plugs were covered in Chapter 2 of this volume. However, in this lesson, we cover certain inspection and replacement requirements.

If fusible plugs are used, see that they are kept in good condition and that they are not used for more than 1 year. When the boiler is down for overhaul, remove the plug for inspection. Scrape clean and bright the exposed surfaces of the plug and the surface of the boiler near the plug. If the plug's metal alloy does not appear sound, replace the plug.

Exercises (649):

1. When do you replace a fusible plug?
2. How is a fusible plug inspected?

650. Cite the requirements for inspecting and replacing boiler access cleanout parts and gaskets.

Inspecting and Replacing Boiler Access Parts and Gaskets. At each regular boiler overhaul, all manhole and handhole fittings and the gasket seating surfaces and the drums and headers must be cleaned, inspected, and repaired, or renewed, if necessary. If the plates are warped, distorted, or otherwise damaged, they must be repaired or renewed.

Whenever handholes and manholes are opened, new gaskets must be fitted. After a gasket has been compressed, it cannot be reused but must be discarded. Be sure to use the correct size and type of gasket. Never use any makeup compound on the seating surfaces when installing the gaskets. Graphite may be used on the threads of the stud to prevent seizure of the nut.

Before installing a new gasket, clean the two gasket seating surfaces (one on the drum or header and one on the plate.) The cleaning must be very thorough. Be sure that you remove all corrosion products or other surface deposits and all adhesive pieces of the old gasket. It is impossible to obtain a tight joint as long as any foreign matter remains on either seating surfaces or in the corners of the fitting.

If the gasket seating surfaces show extensive signs of pitting, it may be necessary to have the surfaces machined or reground. If the seating surface on the manhole or handhole plate is badly pitted or damaged, it may be necessary to discard the plate and replace it with a new plate.

To insure proper positioning of a manhole gasket, contract it on the long axis until the inner edge of the gasket fits the shoulder snugly at the ends of the long axis of the manhole plate. The clearance between the gasket and the shoulder should be equalized at the top and bottom of the short axis. DO NOT allow the outer edge of the gasket to protrude at any point beyond the gasket seating surface in the drumhead. If an edge protrudes, the gasket may unravel when it is compressed by the tightening of the manhole cover.

To install a manhole or handhole plate, first center the fitting in the opening. Make sure that the shoulders do not bind on the edges of the opening. Then slip the yoke on and start the stud nut. Run the nut on the stud until it is hand tight, and then give the nut approximately one-quarter turn with a wrench. Do NOT tighten the nut enough to compress the gasket.

When the boiler is given a hydrostatic test, the pressure of the water usually forces the manhole and handhole gaskets into place, and thus insures proper seating. The plates are first set up tightly. When the boiler is ready for testing, the pressure should be pumped up to within 15 to 20 pounds of the hydrostatic test pressure, regardless of any leakage from the manhole or handhole plates. Leakage is likely to be general at first, but it will decrease as the pressure is increased. When the pressure is within 50 psi of the test pressure, most of the leakage will stop, although the nuts will still be loose.

If some plates are leaking very badly, the trouble is probably caused by improper seating of the gaskets. As a rule, you will find that the gasket is caught on the outer edge, between the edge of the plate and the edge of the counterbore for the seat. A light blow with a hand hammer on the outside of the plate will usually relieve the tension on the gasket and allow it to seat properly.

After the leaky gaskets have been adjusted, and while full test pressure is on the boiler, set up on all plates firmly.

Exercises (650):

- 1. What are boiler access cleanout parts and gaskets inspected for?

- 2. When is it permissible to use a compound when installing gaskets, handholes, and manholes?
- 3. What is one necessary task when replacing gaskets?
- 4. In cleaning gasket seating surfaces, you find they are extensively pitted. What should you do?
- 5. In installing manholes and handholes, what is the proper initial torque?

651. Specify the fundamentals that warrant a safety valve to be tested and replaced.

Testing and Replacing Safety Valves. Safety valves will be kept in good operating condition at all times. If a safety valve opens and fails to reseat itself correctly, and cannot be freed by use of the hand lifting lever, the boiler should be taken out of service, and the safety valve repaired or replaced.

Safety valves should be tested after a hydrostatic test has been made and before the boiler is placed in service. This test is required when the valve has been "gagged" or completely removed and the boiler plugged. Safety valves should also be tested when the valve spring is adjusted.

Safety valves can be tested by opening the valve with the hand lifting gear. This allows dirt and scale from forming and lodging on the valve seat. However, do not operate the safety valve by the hand lifting gear unless the steam pressure is at least 75 percent of the normal operating pressure.

Test safety valves whenever a boiler is returned to service at normal opening pressure by raising the valve to its full open position, then releasing the lift lever to allow the valve to snap shut, as it would had it opened automatically. If boilers are kept in continuous operation for several months, it's recommended, depending on boiler conditions, to repeat the hand lifting at intervals during operation. At least once each year, the valves should be tested by raising the steam pressure to the popping pressure of the



respective valve. If more than one safety valve is installed on the boiler, be sure to gag one to prevent its opening. Pressure may be regulated by restricting flow with the boiler steam outlet valves and increasing the firing rate.

Safety valves will be replaced when defective or when there is a change in conditions that affects the working pressure, the heat absorbing surfaces or the capacity of the fuel-burning equipment, air supply, or draft.

For convenience, a small chain or wire attached to the levers of the safety valves may be used, but a counterweight must be used to prevent the weight of the chain or wire from pulling the valve partly open. Escape pipes that carry the discharge from the safety valve should be installed and supported to prevent any stress upon the valve. These pipes should have no more than two 45-degree turns and be located where injury to personnel or equipment will be avoided.

Exercises (651):

1. When should safety valves be tested?
2. What are the methods of approved testing of safety valves?
3. What governs the replacement of safety valves?

3-2. Fireside Maintenance

The boiler firesides must be kept clean. The burning of any fuel product tends to be incomplete, thus leaving soot and carbon deposits on the boiler firesides. These deposits seriously reduce the efficiency of a boiler. If soot is allowed to remain on the boiler firesides for any length of time, the sulfur in the soot combines with moisture to form sulfuric acid, which attacks tubes, drums, and headers.

You will find that keeping the firesides of the boiler clean will actually save work, as well as saving the boiler. Clean tubes do not collect soot as readily as dirty tubes. Also, firesides that are only slightly dirty are easier to clean than those heavily coated with soot and carbon.

652. Specify the tasks involved in inspecting and cleaning the fireside of a steam boiler.

Inspecting and Cleaning Fireside. To begin with, follow the same procedures in inspecting and cleaning the boiler fireside, as was stated for inspecting and cleaning the watersides of the boiler.

Inspect the conditions of all supports and hangers. Check the refractories (cracks, openings, spalling of bricks, etc.) and the expansion joints. Check the condition of the baffles. Carefully inspect the tubes, especially in the vicinity of the soot blowers, for signs of abrasion caused by fly ash or steam cutting.

Make necessary furnace and setting repairs. Remove slag only when it is over 2 inches thick; removing thinner slag may also remove some refractory material. When slag accumulations on the furnace floor become so large that they interfere with proper operation, remove all the slag and repair or rebuild the floor, as required. Use materials specified for the particular furnace being repaired. Clean and repack expansion joints; repair any that are damaged or inadequate. Place cardboard or wooden battens in newly made expansion joints; when the furnace operates, the battens will burn out. Patch all damaged refractory materials with plastic refractory material or bricks of the same type as those already installed.

As we have stated, fireside cleaning is essential to proper boiler operation and efficiency. A good method to use is mechanical cleaning. This should be considered as the basic and preferred method of cleaning firesides. Soot, carbon, and other deposits are loosened by wire brushing, scraping, and probing. Air can be used to blow out access from the tube banks, etc. Always use a respirator mask when mechanically cleaning, as the dust that is stirred up is toxic.

Exercises (652):

1. What inspection tasks are involved in inspecting the fireside of a boiler?
2. What tasks are involved in cleaning the fireside of a boiler by the recommended method?



Figure 3-3. Standard firebrick.

653. Identify the types of refractory material.

Types of Refractory Materials. There are many different types of refractory materials on the market today. Each manufacturer recommends their product and lists various reasons why such products are superior to others. However, the heating specialist should know the uses of firebrick, insulating brick, and ordinary building brick and mortar.

Standard firebrick. Standard firebrick is made chiefly of refractory clay. It may be either hard and dense or comparatively soft depending on the treatment during its manufacture. Firebrick of this type is used in direct contact with the flame and withstands a temperature of approximately 3000° F. before it will melt or fuse.

Standard firebrick is manufactured in various shapes and sizes. The firebrick shown in figure 3-3 is 9 inches long, 4½ inches wide, and 2½ inches thick. However, all other shapes of firebrick are usually 9 inches long with various widths and thicknesses to fit the spaces desired during refractory construction. See figure 3-4.

Plastic firebrick. For normal refractory work, standard firebrick is generally used, but plastic firebrick is recommended for emergency patching and building furnace openings. Plastic firebrick is unburned brick in a stiff plastic condition. Because of its plastic nature, it can be pounded into a cavity or space where a prefabricated firebrick would not fit unless the cavity was chiseled to the proper dimensions. The fusion point of plastic firebrick is practically equal to that of the standard firebrick, but due to the additional

435
moisture in the plastic firebrick, a greater degree of shrinkage will result.

In general, plastic firebrick is used during the construction and repair of sidewalls, backwalls, burner openings, and any other irregular construction of the combustion chamber not exposed to a temperature in excess of 3000° F.

Plastic firebrick is shipped in light metal drums weighing between 75 and 200 pounds. Wooden heads are provided to give the drums strength, but due to the weight of the material, it frequently happens that the drums or heads are cracked or broken by rough handling. When this occurs, particularly if the drums have been in storage for some time, the plastic will be partially dried. To restore the plastic to a workable condition, the plastic may be treated, as explained in the following paragraphs.

Remove all the plastic from the broken drums and cut it into small chunks. Spread the plastic chunks on the boiler floor and sprinkle them lightly with water. Immediately cover the plastic lumps with damp burlap for about 12 hours. Then pound the plastic into a workable consistency with a mallet. It is then ready for use.

If you plan not to remove the plastic from the drums until it is workable, drill a number of 1-inch holes into the plastic about 12-inches deep and fill the holes with water. It may be necessary to refill the holes with water, but do not add more than 10 percent of the weight of the plastic material, exclusive of the drum.

Care should be exercised to prepare the plastic firebrick material into a stiff workable consistency. Too much water added to the plastic causes excessive shrinkage when heated. Too little water will not permit the plastic to bond properly. Plastic firebrick should never be thinned with water to such a consistency that it can be used for a thin layer of patching.

Insulating firebrick and insulating block. Insulating brick is made of fire clay and possesses a high insulating value and ability to withstand high temperatures without shrinkage. Insulating brick may be used for service in direct contact with the flame and hot gases where the temperatures do not exceed 2600° F. It is available in all standard 9-inch series shapes.

Insulating brick is porous, light in weight, and possesses a heat conductivity of less than one third that of heavy firebrick. Due to its excellent insulating qualities, brick of this type is frequently used between the inner firewall and the outer wall of a boiler for the

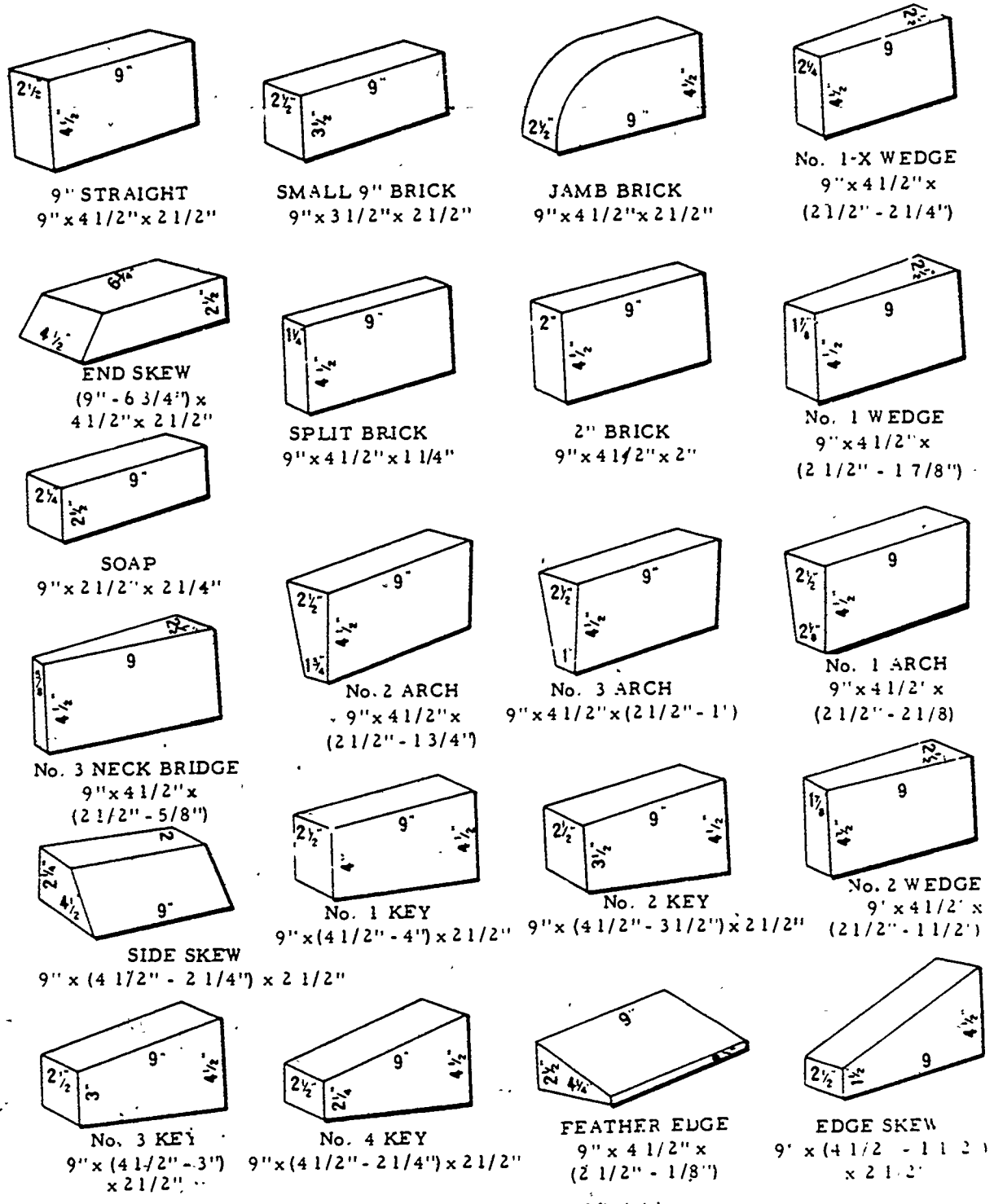
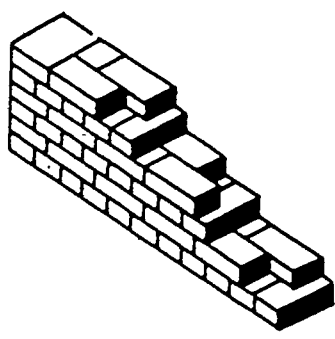


Figure 3-4. Types and sizes of firebrick.

purpose of reducing heat loss from the combustion chamber. Because insulating brick is soft and porous, it must be handled carefully to prevent breakage. Insulating block is made from uncalcined diatomaceous earth and a bonding material to

make it hold its shape. It will not stand exposure to direct flame, but it withstands temperatures up to 1500° F. It is used as the first insulating layers against the metal casing. Various methods are used to tie the block to the casing. It is lightweight and porous and



CGL-009

Figure 3-5. A bond for a 9-inch wall.

must be handled carefully. Standard sizes of insulating block are 1" x 6" x 18" and 1" x 6" x 36"

Building brick. Standard building brick is made by molding a mixture of sand and clay and baking the mixture in a kiln. Building brick is usually used to form the outside portion of a boiler combustion chamber wall. The brick affords protection to the insulating brick and adds strength to the construction of the boiler assembly. Ordinary building brick is 8 inches long, 4 inches wide, and 2 inches thick. Brick of this type is less resistant to high temperatures and should not be used as a substitute for firebrick or insulating brick.

Baffle mix or castable refractory. Castable refractory is a granular material composed of calcined flint clays, refractory clays, and cement. Castable refractory is used around burner ports, peepholes and for patchwork. Castable refractory can be safely used any place where the temperature does not exceed 3000° F.

Plastic chrome ore. Plastic chrome ore (PCO) is quite different from the fire clay base materials used in construction of furnace walls. It is a mined chrome ore called chromite. Chromite is mined in Cuba, South Africa, Turkey, Russia, and Caledonia. The material is used in the same form as it was when mined.

Plastic chrome ore is used for baffles to direct the gases of combustion and to protect headers, drums, and areas where high temperatures are not desired. For instance, the temperature of the surface exposed to the flame may be 3000° F. but the temperature at the point of contact with the tubes only a few hundred degrees. This is a drop in temperature of about 2500° F. in a thickness of about one-inch and it is doubtful that any clay or other type of material would withstand this treatment.

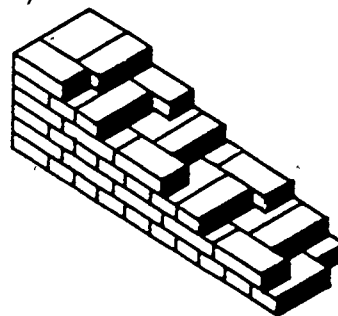
Mortar. Mortar is a mixture of fire clay, water, and sand. It is used for setting firebrick, insulating brick, and building brick when constructing boiler combustion chambers, walls, supports, etc. Mortar should be uniformly fine when mixed. Any lumps in the mixture should be broken during the mixing procedure. Sufficient water should be added to the mixture so that when a sample of it is placed between two bricks and the top brick raised with the hand, the stickiness of the mortar should almost hold the bottom brick to the top brick. This consistency should be maintained during the process of bricklaying by stirring the batch of mortar at frequent intervals.

Exercises (653):

1. What are the different types of refractory material?
2. Which type refractory material is used in direct contact with the flame?
3. What temperatures should most of the refractory material be able to withstand?

654. Describe the tasks involved in repairing or replacing refractory material and answer key questions about these practices.

Repairing or Replacing Refractory Material. Our lesson begins with a discussion of the various types of bonds used in brickwork.



CGL-008

Figure 3-6. A bond for a 1 3/4-inch wall.

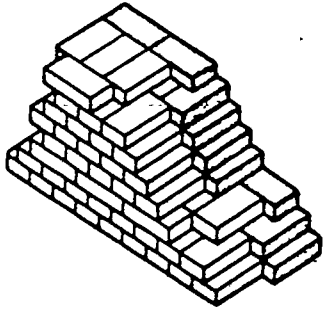


Figure 3-7. A bond for an 18-inch wall.

Types of bonds. Brickwork must be mechanically strong, airtight as possible, and flexible enough to permit component parts of the furnace to expand and contract with rising and falling temperatures. The brick should be laid so that the wall can be repaired and realigned as easily as possible without weakening the wall. All joints should be staggered to cut down air leakage into the furnace or gas leakage out of it.

When constructing a wall for a furnace, the bricks must be laid in a pattern called a bond. There are a great many bonds; however, only a few representative types are discussed here. Figure 3-5 illustrates the arrangement of bricks for a 9-inch wall. If a slightly wider wall is needed, then the bricks may be arranged as those in figure 3-6. This bond makes a 13½-inch wall with no joints extending through it. The arrangement of bricks for an 18-inch composite insulating firebrick wall is shown in figure 3-7. In this illustration, the insulating bricks are those that are shaded. When a wider wall is needed, the bricks may be arranged as illustrated in figure 3-8. A construction of this type is recommended for comparatively high furnace walls where thickness is needed.

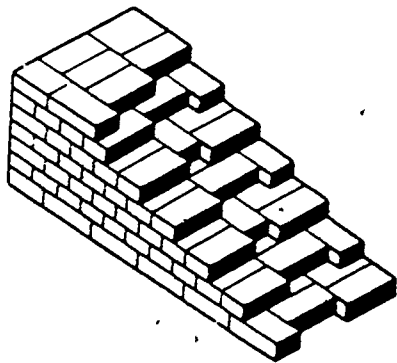


Figure 3-8. A bond for a 22½-inch wall.

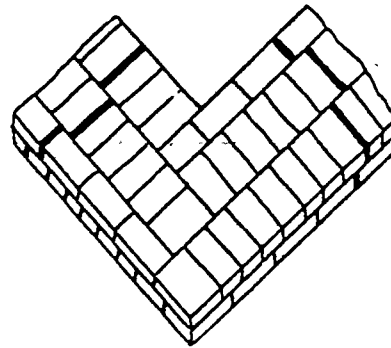


Figure 3-9. Expansion joints in the wall of a combustion chamber.

Expansion joints. Many combustion chambers constructed of bricks fail because no provision is made for normal expansion. This condition results in cracks in the brick joints and allows air to leak into the combustion chamber, making it difficult to regulate combustion. Eventually, if too many cracks develop in the walls, the efficiency of the furnace would become very low.

To prevent combustion chambers from cracking due to expansion, it is necessary to install expansion joints in the combustion chamber brickwork. Figure 3-9 illustrates staggered expansion joints in the corner construction of a typical furnace wall. These expansion joints usually extend the height of the wall. Expansion joints are normally caulked with asbestos rope or other suitable material that allows movement of the bricks and still maintains an air seal at these joints.

Typing brick courses. Sometimes it is desirable to tie standard firebrick to the outer brick wall. For this purpose, it is necessary to procure notched firebrick and tying irons and construct the wall in a manner shown in figure 3-10. This method is by no means the only one. Some brick courses of a wall may be held together by bolts that extend through the complete wall.

Installing openings. When it is necessary to install peepholes and fire access doors in a firebrick wall, some type of support, called a

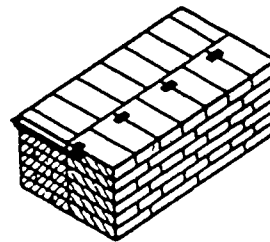


Figure 3-10. Tying firebrick to outer wall.

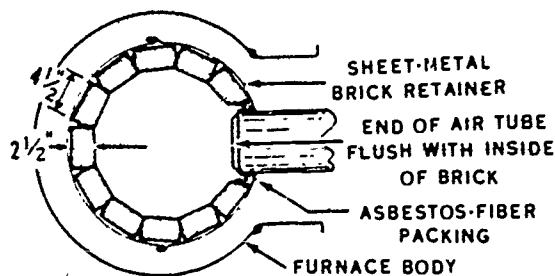


Figure 3-11. A refractory lining on a round firebox.

lintel, must be placed at the top of the opening. In such a case, a square tile or iron plate may be used.

Refractory lining. The simplest refractory lining is used in small coal, gas and coal heaters, and furnaces. The lining in these units is composed of refractory firebricks placed on end, either in a round or square arrangement, in order to conform with the type of firebox. An arrangement of a round-shaped furnace lining is illustrated in figure 3-11. The refractory bricks may be held in place by a sheet metal brick retainer. This retainer is made in two pieces. These pieces are hooked together after they are placed inside the furnace. The space between the bricks is then filled with refractory mortar. In some cases, refractory firebricks are molded in special sizes and shapes to fit specific fireboxes. Firebricks of this type usually do not require mortar to seal the joints because they fit closely together.

Firebox boiler linings. Boilers that are designed with the firebox as an integral part require only a refractory lining for the floor and walls. The refractory lining is laid in courses using firebricks and insulating bricks. Much care should be taken when laying the bricks so that the inside firewall is comparatively smooth.

When the mortar and bricks are in

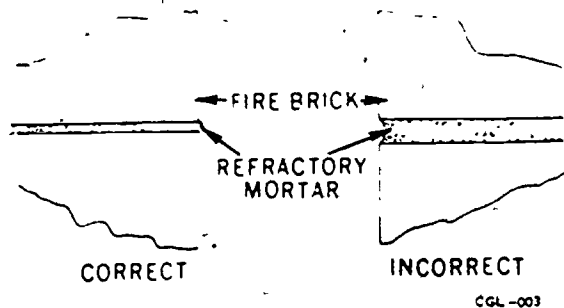


Figure 3-12. A beaded joint between firebrick.

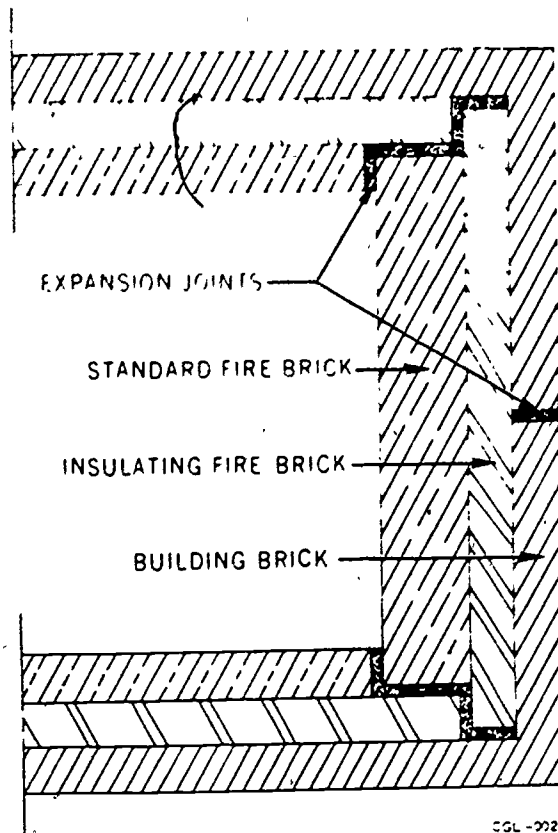


Figure 3-13. Types of brick in a furnace wall.

readiness, begin laying the bricks. Inspect each brick for flaws and evenness of dimensions. Select the best edge of the brick for the inside surface exposed to the flame. Dip the brick in water and allow the excess water to drip off. Then dip one end and side of the brick into the mortar. In dipping the brick into the mortar, use an edgewise motion to prevent the formation of air bubbles on the surface of the brick. Allow the excess mortar to drip off the brick and lay it in position in the wall. Tap it into place in order to squeeze out as much mortar as possible from the joints. These joints should be made as thin as possible, not over one-sixteenth of an inch thick. The side of the bricks exposed to the flame should not have any projecting edges. Quick deterioration of these edges will result when they are exposed to the flame. With a trowel, bead over the joint between the bricks, as shown in figure 3-12.

Some manufacturers recommend that the entire inner wall of a newly constructed combustion chamber should be sprayed with a thin layer of mortar cement. It is generally recommended that the firebox of the furnace be allowed to dry for 12 hours before firing.

440

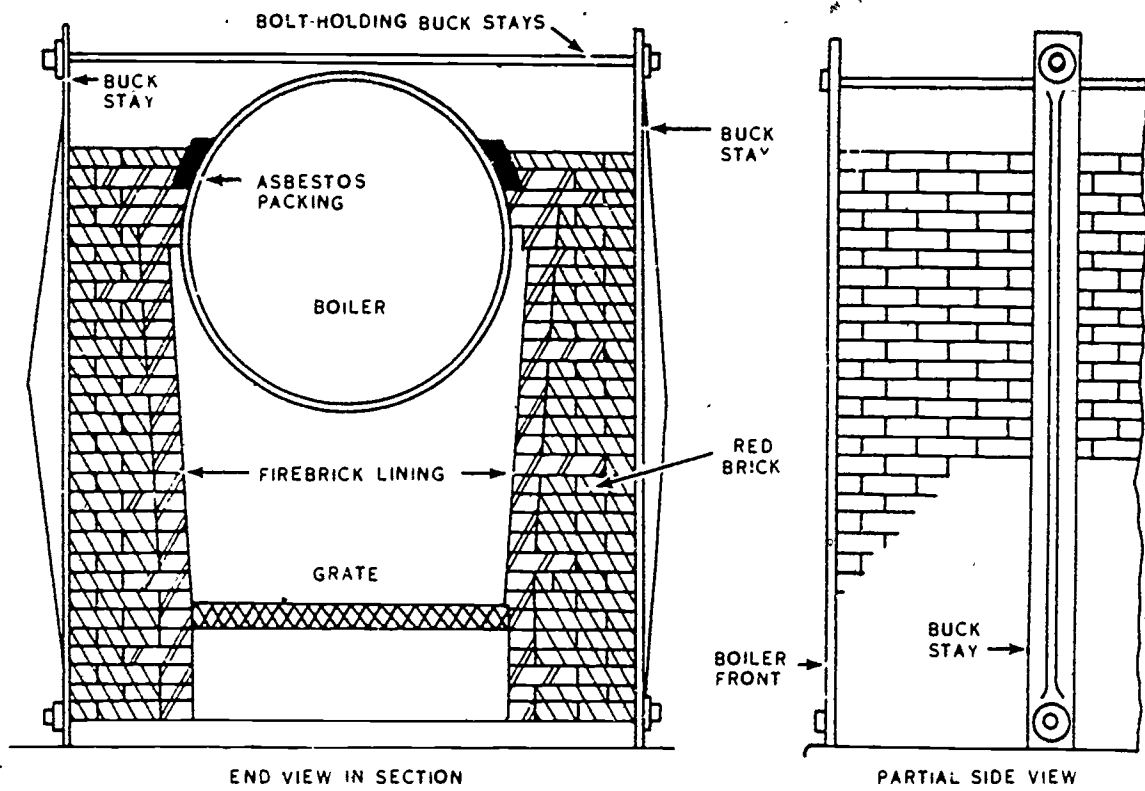


Figure 3-14. A solid wall for a boiler.

At this time, the boiler should be started and slowly brought to operating temperature. Some mortars require more time to set before firing, while others of the heat setting type require less time. It is recommended that the manufacturer's instructions pertaining to the application of the mortar be followed when laying brickwork.

Plastic firebrick may also be used as a refractory material for linings. However, its length of service is much less than that of standard firebrick. When laying chunks of plastic firebricks just as they are taken from the can, the chunks should be rammed tightly into place, preferably in horizontal layers. In general, the more solidly the section of plastic is rammed together, the better it will be. The plastic section then should be vented with three-sixteenths inch holes extending through the plastic and not more than 1 inch apart. This allows deeper heat penetration during the vitrification process and also permits the escape of steam formed from the moisture in the plastic; Vitrification is the process of changing to a glass-like structure. It is not recommended to trowel the surface of a new plastic section, since this tends to prevent the

escape of steam during the vitrification process.

The plastic section should be held in place with as many anchor bolts as would have been provided had standard firebrick been used instead of plastic firebrick. The plastic section should be air-dried from 48 to 72 hours, depending on the humidity in the atmosphere. As soon as practicable after air drying, the furnace should be fired with a low fire and gradually brought up to operating temperature. This permits vitrification to take place. Plastic requires a temperature of about 2900°-3000° for vitrification. Should any shrinkage cracks open up during this process, they should, if small, be filled with fire clay; if large, with plastic. If the plastic section is not vented, it will be necessary to bake it from 24 to 36 hours at a low temperature prior to vitrification.

Boiler settings. In large installations, the entire combustion chamber must be built under the boiler. The brickwork surrounding the combustion area is usually composed of two or more rows of bricks, as shown in figure 3-13. The inner row next to the fire is built up of firebrick, using a high temperature

413

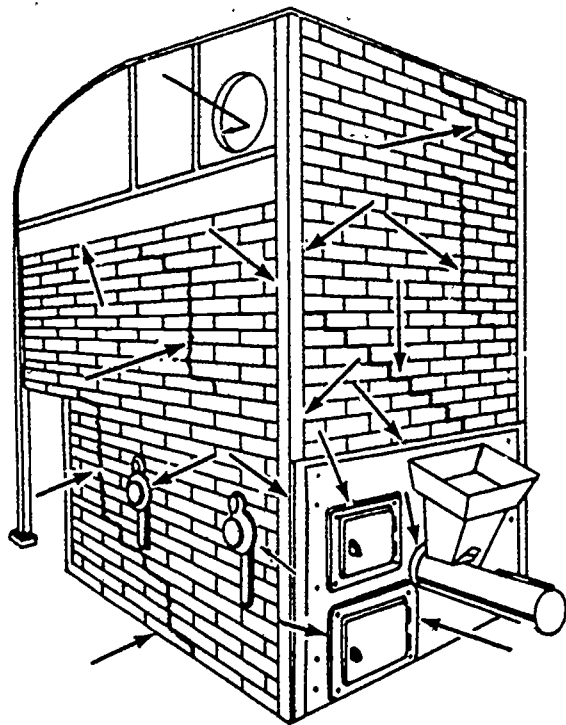


Figure 3-15. Cracks and leaks in a boiler setting.

mortar to bond the brick together. This brick must be able to withstand the heat of the flame. Surrounding the wall of firebrick is a wall of insulating firebrick. The purpose of this brick is to prevent the loss of heat from the combustion chamber to the outside of the furnace. A third row of brick is laid next to the insulating brick. This is common building brick. It affords protection to the insulating brick and added strength to the construction of the furnace.

Usually, the brickwork around a boiler is held together by bolt-holding buck stays, as shown in figure 3-14. Whenever brickwork encloses a boiler or where parts of the boiler project through the walls, provision must be made to permit relative movement between the boiler and brickwork because of the difference in expansion. The joints which permit expansion must be constructed in such a manner that air will not leak into the setting or gases leak out of it. The seal normally consists of asbestos rope or fibers, which are packed into the joint and kept in place by a plastic compound.

Bricklaying procedure for boiler settings is the same as the procedure for the erection of refractory linings in a firebox boiler. Plastic firebrick may be used when building a boiler setting. It is best adapted for use when constructing peepholes, inspection holes, and

places where irregularly shaped bricks are needed.

Repairing linings. Standard firebrick is generally used for refractory brickwork. However, plastic firebrick is recommended for emergency patches and for building furnace openings. Where a damaged section of brickwork is found, the old brick and mortar should be removed and new installed, making certain that the fresh mortar completely fills the space between the old brick and the new brick. When plastic firebrick is used for patches, as in case of a brick falling out, the hole should be cleaned out at least 4 inches deep and cut wider at the inner side (away from the fire) so that the plastic will wedge and not fall out. Using a mallet, the plastic is pounded into the hole until it is completely filled. A crack can be repaired by chipping a channel down through the crack and filling it with plastic firebrick or fire clay. Good practice is to thoroughly wet the sides of the hole with water before filling it with new fire clay or plastic firebrick. Doing this reduces the absorption of moisture by the old brick from the new, thereby improving the bonding action. It is very important that the mortar be properly mixed for best results. The mortar, whether fire clay or fire cement, should be free of lumps and should be mixed only with fresh water. Sufficient water should be added to make a rather thin mortar. This will insure thin joints, which are essential.

The boiler is the principal and most costly unit in a boiler plant. Preventive maintenance of the unit represents the difference between a normal, useful life extending to 50 years or a short life with much time lost for repairs and a ruined boiler in a few years. All boilers have common characteristics and require similar care. In general, the outside as well as the inside surfaces of a boiler should be kept clean. All outside surface water leaks should be stopped. Small water leaks, if allowed to continue, become larger and require major repairs. Water leaks frequently provide moisture on metal surfaces, which are the basis for corrosion and more leaks. Stop the leaks at once, prevent their spread, and prevent boiler corrosion and boiler setting deterioration.

Air leaking into the setting of a boiler causes cooking and dilution of the combustion gases and must be held to a minimum in order to insure adequate steam generating capacity and efficient operation. Cracks and leaks usually start around drums or other places where a strain is placed on the setting, as shown by the arrows in figure 3-15. These cracks should be filled immediately

442

with a filler material. If a setting is completely covered with many small cracks, then the setting should be covered with a boiler seal coat. This coat is applied with a trowel and is about one-fourth inch thick. The material is manufactured with an asphalt base, which causes the surface to get moderately hard; but underneath, it remains quite soft.

The area between the drum and the brick setting usually develops air leaks because of expansion. This area must be filled with a refractory material that will not hinder the movement of the drum or the setting under heat. If there is any question about the hardness of this material, it should be removed and relaid with a soft material that will not cause binding between the drum and setting. Such an area will usually open in one place when the boiler is cold and in another place when the boiler is hot. After a boiler has been on the line a short time, the drum should be inspected and any openings plugged with an expansion joint filler, asbestos packing, etc. The interior of the combustion chamber should be inspected for spalling, slagging, cracked or broken bricks, and damaged arches and baffles. Occasionally, it is necessary to chip away slag and clinkers formed on the linings. This may be done with a chisel and hammer.

Minor repair. Plastic firebrick is especially useful for quick patchwork, such as replacing spalled brick faces. When patching spalled brick faces, be sure to remove all ash, slag, or foreign material on the remaining brickwork. Without removing an excessive amount of the good brick, make the area to be patched as rough as possible. A patch of this type should be made only as a temporary measure; it will not last for any great length of time. For a more permanent job, the firebrick should be removed back to the insulating brick. For large patches, use as many firebricks as possible and build in the remainder of the wall section with plastic.

Major repair. After an inspection of the furnace has been made, and it is determined that minor repairs will not suffice, plans should be made to completely rebrick the damaged wall or floor area. If a set of prints showing the location of expansion joints and the number of bricks of each type to be used in the furnace is not available, the man in charge should count the number of bricks needed and notate the exact location of all expansion joints. The availability of material needed for the job should be insured before the wall or floor is removed. After the damaged wall or floor is removed, the furnace should be cleaned and inspected. If the

furnace is of steel construction, the furnace should be checked for proper alignment and repaired before new brick is installed.

The first material installed is the 1" x 6" x 36" insulating block. This is laid flush against the floor or wall making sure to always break joints. No cement or mortar is used. Extreme care should be used so as not to break any corners off the insulating block. When corners are broken, blocks should be sawed off square. The second material to be installed is the 2 1/2" x 4 1/2" x 9" insulating brick. It isn't required to use mortar for insulating brick; but, if mortar is used, it should be mixed to a thin dripping consistency. The second row of insulating brick should be rubbed against the first row making sure to obtain a tight joint. Continue doing so until the course is finished. Where the expansion joint is to be located, a split insulating brick 1 1/4" x 4 1/2" x 9" should be used with a 1 1/4" x 4 1/2" x 9" firebrick laid on top. The reason for this is to prevent hot flames of combustion from burning out the insulating brick behind an expansion joint.

The final material to be installed is the 2 1/2" x 4 1/2" x 9" firebrick. Much care should be taken when laying this course of brick. The work should be under constant, experienced, and intelligent supervision. The brick should be laid up even and straight making sure that the seams between each brick are as small as possible—not over one-sixteenth inch. Inspect for flaws and insure that the dimensions are even. Choose bricks with the best edges and without broken corners. Dip the brick in mortar and allow excess to drip off. DO NOT PLACE ANY MORTAR ON THE WALL OR BRICK WITH A TROWEL. THE MORTAR ADHERING ON DIPPING IS ALL THAT IS USED. Place the brick quickly into position against the wall and pound into place with a wooden mallet until no more mortar can be forced out of the joints. The thickness of the joints will depend upon how even the surfaces of the firebricks are, but the joints should never exceed one-sixteenth inch. The furnace face of the bricks should all be in the same plane without any of the edges projecting and thereby exposing them to the flame. This would cause rapid deterioration of the brick.

Installing plastic firebrick. Plastic firebrick material, as received, normally contains sufficient moisture for working, and the addition of water or any foreign material should be guarded against. Any one wall of the furnace setting should be completed in the same day, if practicable; otherwise, the unfinished portions should be kept moist until work is resumed. The two primary factors affecting the life of plastic refractory

443

are the quality of the plastic and the method of installation. It is, therefore, important that the instructions discussed below for laying up the plastic be carefully followed, so far as is practicable.

Ramming is very important in the laying-up process. To begin, remember that the plastic should be built up in a vertical direction. First, cover the firebrick with a layer approximately 2 inches thick of fist-sized lumps of plastic. Then ram hard the layer of plastic, using a wooden mallet and pounding on a slight angle toward the casing. If the edge of the mallet is used to strike the surface of the plastic, a roughened surface will aid in binding the next layer in place. Layer by layer, the plastic should be built up around the burner form. A form smaller than the burner cone angle is desirable as this allows room for ramming and helps prevent voids in the plastic forming the burner cone.

When the job is completed, the excess plastic should be cut or scraped off to proper thickness. Next, remove the forms and cut the excess plastic from the burner cone with a sweep. After the burner cone has been swept, the sweep should be used to test the angle of the burner. The next step is to take a coarse wire brush and brush the entire surface of the plastic to be sure there are no smooth surfaces to prevent the escape of moisture. Vent the plastic on 1½-inch centers by plunging a ¼-inch rod, tapered to a blunt point, through to the insulating block. The vent holes in the burner openings should be made in the same direction as the remainder of the wall.

This plastic is vented to allow for the rapid loss of moisture, since this type material contains about 10 percent of water by volume when installed. If for any reason this water is trapped within the plastic or behind it, steam would be generated as the boiler temperature is increased and an explosion would take place causing the plastic to be displaced. If the actions were not rapid enough to cause an explosion, cracking would occur, and the plastic would soon fall from position. Venting also allows the heat to penetrate deeper into the body of the plastic and thus increase its strength through proper curing. Since this material is basically a mixture of raw clay and flint clay, a ceramic bond in this type material does not start to form until a temperature of 1500° F. is reached.

Since all plastic is installed after the brickwork is complete, a fire should be started in the boiler immediately after the plastic installation is complete. This method of drying is the only approved way, since

complete air drying causes excessive shrinkage and ceramic bonding will not take place.

For small boilers, a small wood fire or a small capacity nozzle should be used. The refractory should be heated slowly for a period of 6 hours, during that time a dull red glow should be obtained. The boiler should then be fired to the maximum temperatures used under normal operating conditions.

For larger units, with more than one burner installed, the center burner should be lit off using a small size nozzle or low fire setting. The burner should be operated for 15 minutes, after which the adjoining burner should be lit off and the center burner secured. Continue this method of using the burners in rotation for a period of 6 hours. The boiler can then be used for operation.

Exercises (654):

1. When you are arranging a furnace wall and you are installing bricks in a specified pattern, what is this called?
2. What are some requirements for installing brickwork?
3. What practice insures suitable movement of expansion joints and yet maintains an air seal?
4. What do you use when a peephole must be provided?
5. State some tasks involved in laying firebox boiler linings.
6. How long should you allow the firebox to dry after a new lining has been laid?
7. Describe the main tasks involved in repairing a damaged section of brickwork.
8. What is of prime importance in using plastic firebrick material?

655. Specify fundamentals of boiler smokebox and stack inspections.

Smokebox and Stack Inspections. Inspecting and cleaning of stacks, breechings, and smokeboxes are performed simultaneously. A smokebox refers to the rear end of a Scotch-type boiler. It is the area where combustion gases pass before they are returned through tubes to the uptake chamber and up the stack. All material concerned with inspections and cleaning of stacks will also apply to smokeboxes for this section.

Stacks were covered in Chapter 1, Volume 3, so we will concentrate just on the inspection and cleaning of certain stacks.

Steel stacks.

a. Quarterly. Inspect the steel surfaces and guys for erosion, corrosion, leaks, loose parts, or other defects. Use a pair of high-powered binoculars for visual inspection. Remove soot and fly ash accumulations from base of stack. The kind of operation, equipment used, and fuel burned will determine the frequency of periodical cleanings.

b. Special inspection. After a severe storm, inspect the stack, as instructed in the quarterly inspection above.

c. Yearly. Clean and inspect the stack internally and externally. Check the soundness of metal by making a hammer inspection. Check thickness of metal wall in several areas and record data for future reference. Inspect seams and areas around stiffening rings, lugs, etc.

Brick stacks.

a. Quarterly. Clean out the base of the stack. The frequency of cleanings will depend on the type of fuel burned, kind of operation, and equipment used. Inspect the stack externally from the ground, using a pair of high-powered binoculars. Look for cracks and external damage.

b. Special inspection. After a severe storm, inspect the stack, as instructed in the quarterly inspection above.

c. Yearly. Clean and inspect the stack internally and externally. Inspect lightning-rod tips and ground connections. Inspect crown for security and tightness.

Concrete stacks.

a. Quarterly. Inspect the stack from the ground, using a pair of high-powered binoculars. Look for cracks, spalls, exposed steel rods, or other damage. The first indications of deterioration usually appear on the prevailing windside of the stack. Remove

444

soot and fly ash accumulations from the base of the chimney through the cleanout door. After cleaning, shut the door tight.

b. Special inspection. After a severe storm, inspect the stack, as instructed in the quarterly inspection above.

c. Yearly. Clean and inspect the stack internally and externally. Inspect lightning-rod tips and ground connections. Inspect crown for security and tightness.

Maintenance of Stacks.

a. Steel stacks. Keep metal surfaces painted with heat and corrosion resistant paint. Replace badly corroded or damaged sections.

b. Brick stacks. Repair all refractory damage with the best quality bricks and cement, after the area has been thoroughly cleaned of ash and other deposits. Once a year, determine ground resistance with a "megger" which indicates resistance in ohms. Ground resistance indicates ground connection effectiveness. The higher the resistance, the less effective the ground connection.

c. Concrete stacks. Repairs usually consist of chipping or cutting out the cracked or spalled area, reinforcing the cavity, and patching with new bonding material. Before applying the new bonding material, clean and moisten the damaged area. Ground resistance should be tested at least once a year; it should not exceed 5 ohms.

Cleaning and Maintenance of Breechings. Every 3 months, or more often if required, clean accumulations of soot and fly ash from breeching and inspect them for corrosion and erosion. Cleaning frequency will depend on the type of fuel burned, the kind of operation, and the equipment used. Cleaning personnel should wear goggles and respirators.

During the boiler overhaul, inspect breeching for signs of corrosion and erosion inside and outside. Repair as necessary. See that no moisture can enter the breeching; water combines with the sulfur in the combustion rejects to form corrosive sulfuric acid. Clean and paint metal with heat and corrosion resistant paint. Repair insulation. Stop leaks and drips on outside surfaces of the breeching.

Exercises (655):

1. Steel surfaces and guys of the steel stacks are inspected for what?

445

METHOD OF TESTING LOW PRESSURE GAGES WITH HEAD OF WATER

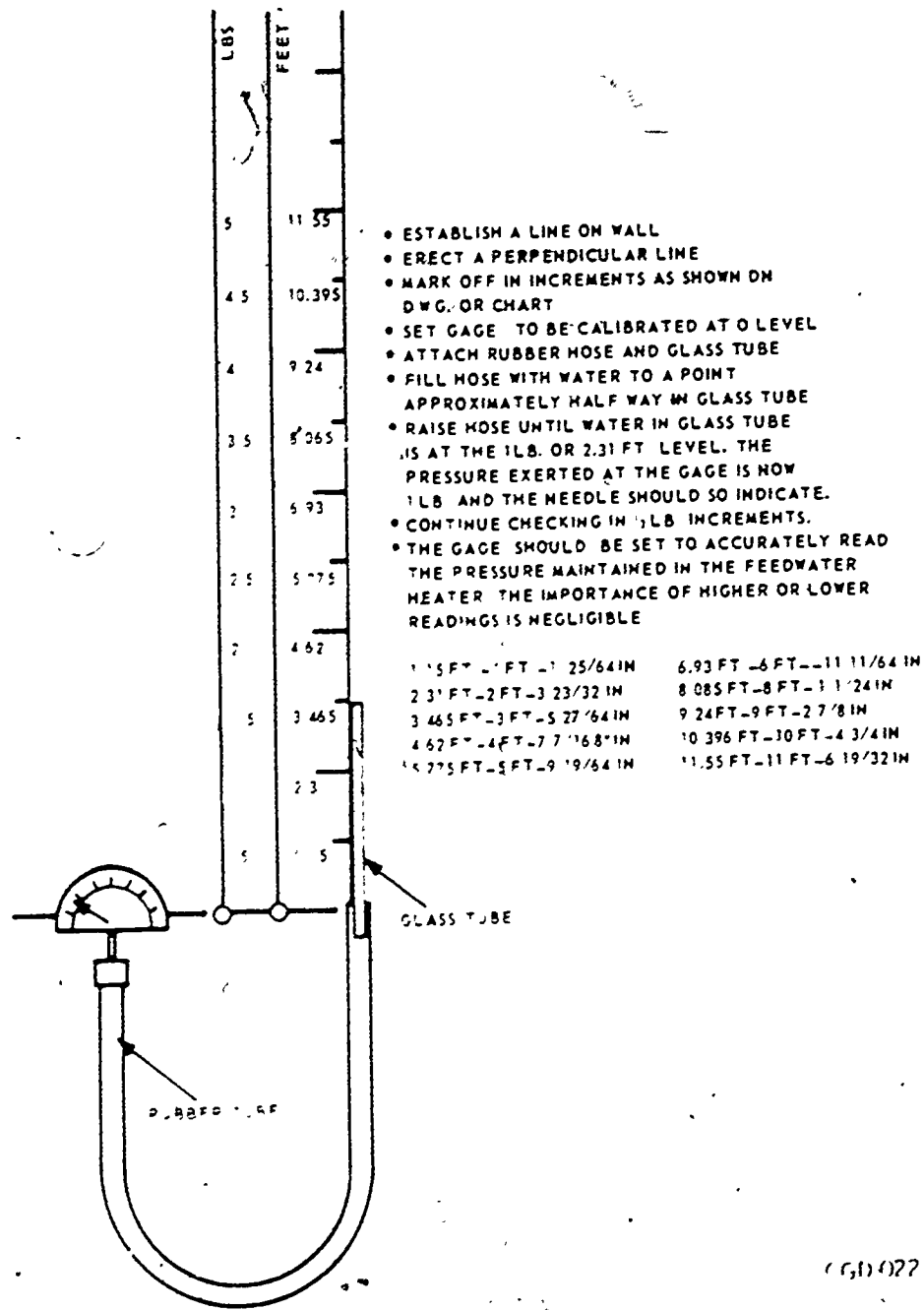


Figure 3-16. Testing low pressure gages with head of water.

2. What determines the frequency of inspection and cleaning of steel stacks?
3. When are special inspections performed on stacks?
4. Annually, an inspection is performed to determine the ground resistance. This inspection is made with what?
5. What are smokeboxes inspected for?

455

6. How often are breechings cleaned?

446
accurate (in percent) will you be able to compare the results?

656. Cite the fundamentals of calibrating and replacing gages.

Testing Gages.

a. Low pressure gages. Figure 3-16 shows how to test the low pressure gages normally used for feedwater heater service.

b. High pressure gages. Test medium and high pressure gages by comparing them with a laboratory test gage used as a reference. Laboratory test gages are usually accurate to within $\frac{1}{4}$ of 1 percent. Test gages should never be used as service gages. Adequately pressurized air is a convenient pressure source when checking gages. Install an air-filter ahead of the connection to the gages to provide them with clean air during the test.

c. Dead weight tester. Often, a dead weight tester is used to periodically check test and service gages. The dead weight tester is a hydraulic unit, precision built to obtain basic pressure standards. It consists of a manually operated oil pump assembly in which a weight platform is supported by a piston. A valved connection is made from the oil pump to the gage being tested. In operation, calibrated dead weights are placed on the weight platform and the pump is manually operated until the platform is freely supported by the piston. The oil pressure developed (which is shown on the gage dial) must correspond with the pressure stamped on the calibrated dead weights.

Calibration of Pressure Gages. The gage's pointer must be reset to indicate the correct pressure shown by the testing method used. Some gages are calibrated by adjusting screws in the lever system mechanism. Refer to manufacturer's instructions for the correct method of pointer resetting system and hair spring adjustment.

If the gage cannot be repaired or calibrated, it should be replaced. Always remember, in installing or replacing a Bourdon-type pressure gage, that steam or high pressures should never come in direct contact with the gages mechanisms; therefore, be sure to use a siphon or water leg or a snubber in replacing or installing a Bourdon gage.

Exercises (656):

1. In calibrating a high pressure gage, how

2. What media is normally used to test and calibrate high pressure gages?

3. In replacing a gage of the Bourdon type, what precautions should you always take?

4. What do you compare the gage reading to when using a dead weight tester?

3-3. Distribution Maintenance

For purposes of this section, a distribution system consists of all the steam supply and return piping, related facilities, and equipment used to convey steam from a central steam generating plant to consumers and to return the condensate to the plant.

All of the piping, both supply and return, the related facilities, and equipment must be inspected and maintained at certain intervals to insure a proper operating condition. Under a good inspection and maintenance program, irregularities in the condition and operation of equipment will normally be detected early and can be corrected before a major breakdown. This type of maintenance increases the dependability and useful life of equipment and results in more efficient and economical operation of plants and distribution plants.

657. List the equipment and fittings that are found in tracing a distribution system and cite the directional rule that usually applies to this task.

Steam is supplied to the consuming equipment in low pressure (0 to 15 psig) and high pressure (30 psig and above). It is distributed at these pressures by either the aboveground system or the underground system.

Aboveground Distribution. The aboveground distribution system is less costly to install and easier to maintain than the underground system. It is generally selected when the lines are for temporary use or the water table is high. Distribution lines are

usually aboveground conduits supported on poles, concrete piers, or other adequate structures, unless such structures interfere with traffic or detract from the appearance of the location. At road crossings, the lines can convert to an underground system, which can also serve as an expansion loop.

Underground Distribution. Underground distribution systems are more common than aboveground ones, since they do not obstruct roads and railroads or create an undesirable commercial appearance. The preferred location is either parallel to the sidewalk or underneath the sidewalk if the sidewalk is the top of a concrete tunnel or trench. In cold climates, the latter location may be preferred, since the radiated heat clears the sidewalk of snow. Systems of pipes thermally insulated and insulated in waterproof conduits are used extensively. Requirements are strict for underground systems in areas where ground water will contact the bottom of the conduit.

Distribution Route. Steam and high temperature waterlines are usually routed to provide the shortest practical distances from the central generating plant to the demand centers. The route must also be selected with proper consideration for future growth, so that planned demand centers can be supplied easily. Make full use of basements or crawl spaces of buildings to house the lines. When buildings are connected by corridors, the lines can be housed in the crawl spaces under floors or run under roofs. Expansion loops and joints should be located inside buildings wherever possible.

When steam is drawn from a high pressure line to heat buildings, etc., the pressure must be reduced to the working pressure of the particular system. This is accomplished by a pressure reducing station. A pressure reducing station may include a pressure reducing valve, or pressure regulating valve, a relief valve, strainer, various auxiliary valves (gate valves and globe valves), and pressure gages. A pressure reducing station will be covered more completely in Learning Objective 667.

There are various valves incorporated in a steam distribution system, such as gate valves, globe valves, check valves, etc. The piping for distribution lines should be black steel, seamless, schedule 40. Pipe joints should be joined by welding or flanged.

Expansion joints are other accessories that will be found in distribution systems. However, the expansion loop is the preferred media for handling expansion and contraction of distribution lines. These will be covered in Learning Objective 662.

Steam traps will be found in tracing a

447
distribution system. They are covered extensively in Learning Objectives 659 and 660.

Continual tracing or inspecting of a steam distribution system along with proper maintenance is an important and necessary task in the process of attaining the highest efficiency possible of a steam heating plant.

Exercises (657):

1. What types of distribution systems are there?
2. In tracing a distribution route, you would most likely find what directional rule applied?
3. List the equipment and fittings found in tracing a distribution system.

658. Specify the tasks involved in inspecting and repairing a steam condensate line.

Inspecting and Repairing Steam Condensate Line. The fundamentals for the inspection and repair of condensate lines are interconnected with the inspection and repair of the complete distribution system; therefore, we will describe the various preliminary and operational inspections and maintenance factors pertaining to the entire steam distribution system.

Operation of steam distribution lines. Before placing a line in service, inspect the installation carefully and make sure that the following *preliminary inspection* requirements are satisfied:

- a. For new installations and replacements:
 - (1) Heat conduit system meets all applicable requirements as stated in current directives and Air Force Guide Specifications for Heat Distribution Systems.
 - (2) Applicable field tests as described in Air Force Guide Specifications for Heat Distribution Systems, satisfactorily completed.

- b. For all systems:
 - (1) All installation, repair, and cleanup work completed, including cleaning and flushing heat carrier pipes.

(2) All conduits and passages tight and free from obstructions.

(3) All insulation properly applied and dry.

(4) All auxiliary equipment required for operation, properly installed, and ready for service; as for example: pressure reducing stations, steam traps, strainers, drains, vents, provisions for pipe expansion, etc.

Operational preventive maintenance of main lines. The operator will report immediately to his supervisors any malfunction or defect in the piping system. If system makeup requirements increase, check the distribution system for possible leaks.

Preventive maintenance inspection of main lines and conduits.

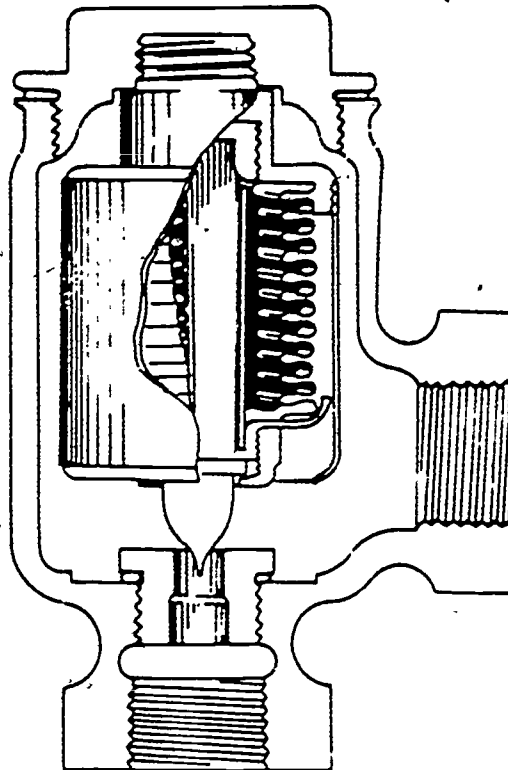
a. Monthly. Check for leaks, defective operation of traps, strainers, moisture separators, valves, pressure and temperature controllers, and all auxiliary equipment, unsatisfactory condition of thermal insulation, abnormal pressures and temperatures, and abnormal pressure drops.

b. Yearly. Check the grade of the lines to determine whether poles, hangers, or other supports have settled or shifted position; condition of thermal insulation; valves; traps; strainers and moisture separators; anchors, hangers, and supports; expansion joints; and pressure reducing valves, setting of relief and safety valves, and condition of flanged fittings. Do not allow leaks to exist for extended periods, they can cause wiredrawing of flanges, insulation damage, and loss of treated water.

Condensate return line. Inspect condensate return piping at least quarterly for signs of corrosion caused by the corrosive gases (chiefly carbon dioxide and oxygen dissolved in the condensate).

Corrosion in condensate return lines and associated equipment is a problem at many Air Force bases. The salts and causticity in the boiler water are not volatile and the condensate is generally rather pure water. However, carbon dioxide does go over with the steam and dissolves in the condensate, lowering the pH of return condensate and making it acid. The carbon dioxide is more corrosive than the oxygen that leaks in at a pipe connection. But when both are present, the problem is intensified and a corrosion problem is likely to exist. Carbon dioxide corrosion usually grooves and channels the bottom of the pipe. Frequently, it is most pronounced just beyond the steam traps. Oxygen corrosion pits the pipe.

Maintenance of lines Make all repairs



CGD-020

Figure 3-17 Thermostatic trap.

indicated by the previous inspections and checks. Repair all pipe leaks immediately by tightening loose connections, repacking valve stems, replacing gaskets, lubricating valves, and welding or replacing defective parts or sections. Control of corrosion in condensate return lines is accomplished by an external treatment method or an internal treatment method. Both of these will be discussed in the following chapters.

Exercises (658):

1. Specify the basic inspection tasks of steam condensate lines.
2. What would an increase in system makeup requirements indicate?
3. Cite the quarterly task performed on a condensate line.

450

449

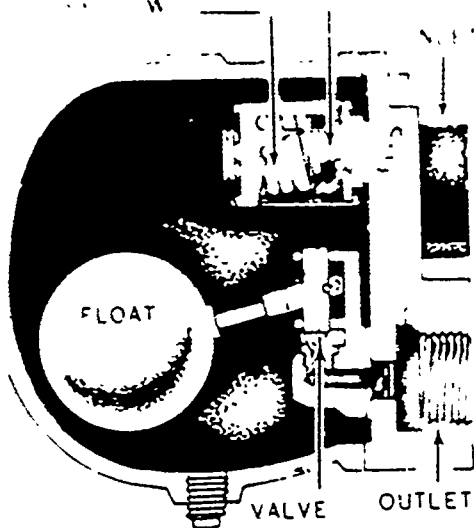
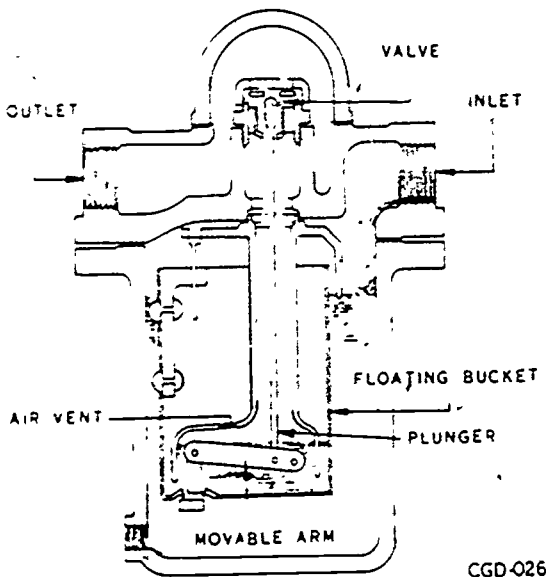


Figure 3-18. Float and thermostatic trap.

4. In general, what indicates the need for repair of steam lines?

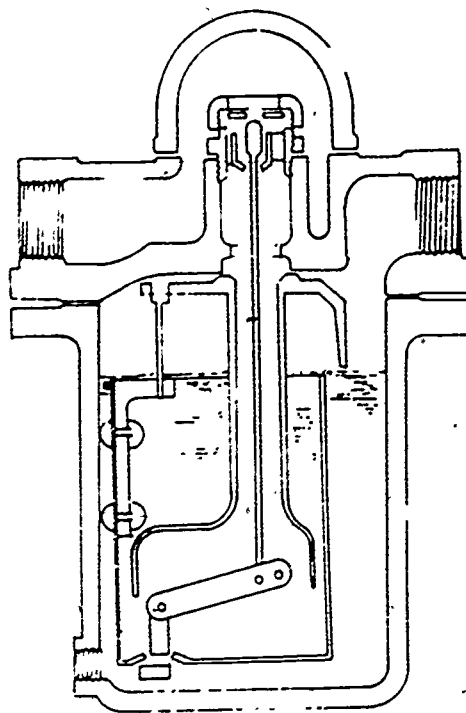
659. Identify types and explain the operation of steam traps.

Types of Steam Traps. Steam traps are automatic devices that drain condensate,



CGD-026

Figure 3-19. Bucket trap with trap closed.



CGD-027

Figure 3-20. Bucket trap discharging water.

remove air and other noncondensable gases, and prevent the escape of uncondensed steam through drain lines.

Traps have the following parts: a vessel where the condensate accumulates; an orifice through which the condensate discharges; a valve to close the orifice port; mechanisms to operate the valve; and inlet and outlet openings through which condensate enters and leaves the trap vessel. Steam traps are classified according to operating device.

Thermostatic trap. Figure 3-17 illustrates a thermostatic trap operated by the expansion or contraction of bellows, which are activated by temperature changes. The chamber inside the bellows is filled with a small amount of volatile liquid, such as alcohol. The liquid expands or becomes a gas when steam contacts the expansive element. The resultant pressure expands the element and closes the valve, preventing the escape of steam. When condensate or air contacts the element, it cools and contracts, thereby opening the valve and permitting the condensate and air to escape. The discharge from this type of trap is intermittent. Some thermostatic traps have metal diaphragms, which function in the same manner as the bellows. Thermostatic traps are usually used to drain condensate from radiators, convectors, pipe coils, drips, unit

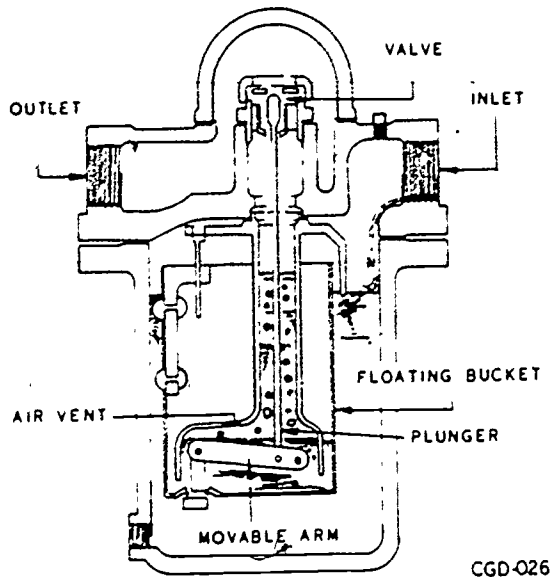


Figure 3-21. Bucket trap after discharging water.

heaters, cooking kettles, and similar equipment.

Float and thermostatic trap. Figure 3-18 illustrates a float and thermostatic trap, which combines float and thermostatic characteristics. As relatively cool condensate and air enter the trap vessel through the thermostatic orifice valve, the condensate level begins to rise. When it reaches the proper level, the float valve operates, discharging condensate and air. When steam contacts the thermostatic valve in the trap inlet, the valve closes, blocking the steam until cool condensate and air are again admitted. These traps are used to drain condensate from unit, blast, and coil heaters that generate large volumes of condensate.

Upright bucket trap. Figures 3-19, 3-20, and 3-21 illustrate the three phases of upright bucket trap operation. In this type of trap, the condensate enters the trap chamber and fills the space between the trap bucket and walls. When this happens, the bucket floats and closes the valve. When the condensate level rises above its edge, the bucket fills and sinks, withdrawing the valve from the seat. Then the steam pressure, acting on the condensate in the bucket, forces the water through the discharge opening. When the bucket is empty, it rises and closes the valve. Then another cycle begins.

Inverted bucket trap. Figure 3-22 shows how the inverted bucket trap operates. In this type of trap, steam, condensate, and air enter under the bell or inverted bucket. The steam floats the bucket and closes the valve. The air

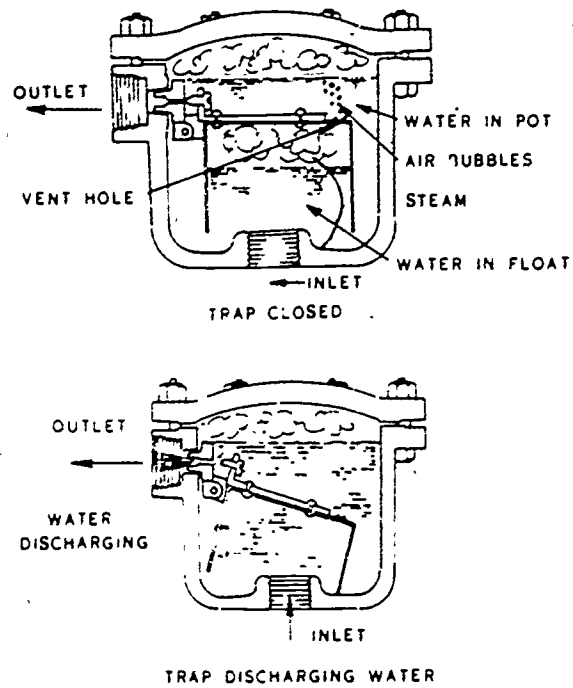


Figure 3-22. Inverted bucket trap.

escapes through a small vent in top of the inverted bucket. As condensate enters the trap, the bucket falls and opens the valve. The condensate discharges through the open valve until steam again enters and displaces the water in the bucket, causing it to rise and close the valve. These traps are particularly

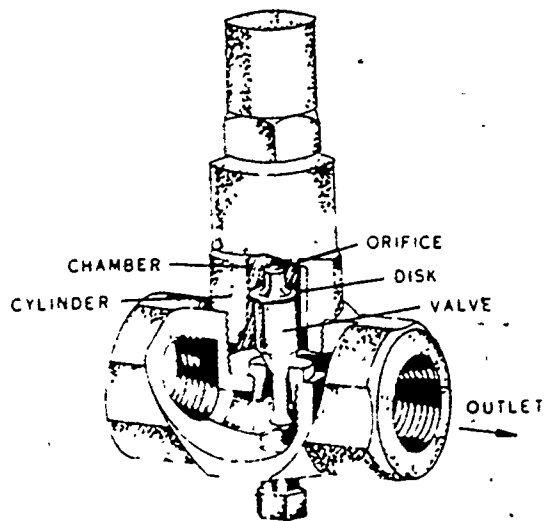


Figure 3-23. Impulse trap.

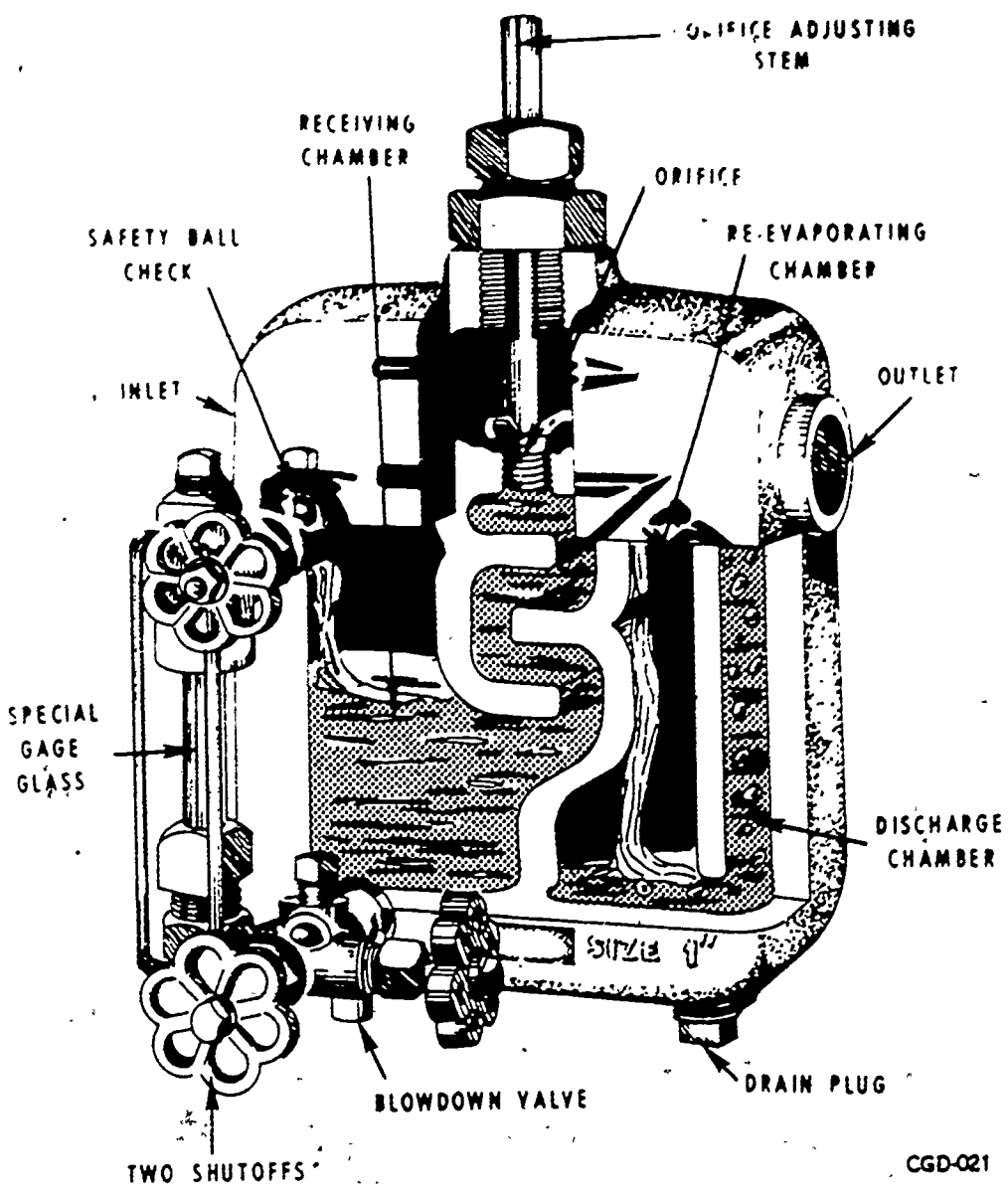


Figure 3-24. Throttling trap.

suitable for draining condensate from steam lines or other equipment where abnormal amounts of air must be discharged.

Impulse trap. In the impulse trap, illustrated by figure 3-23, the flashing action produced by a pressure drop in the hot condensate governs the movement of a valve by changing the pressure in a control chamber above the valve. In operation, condensate builds up pressure below the control disk, lifting the valve like a piston. Air and condensate discharge, and a small portion of the flow (control flow) moves up around the disk to the lower pressure control chamber. The pressure in this chamber remains low while the control flow discharges through the

orifice in the valve body, to the trap outlet side. When condensate reaches near steam temperature, the reduced pressure in the control chamber causes part of the control flow to flash into steam. The increased volume in the control chamber chokes off some of the flow through the control orifice to build up pressure in the chamber. The valve closes and shuts off all discharge except the small amount flowing through the control orifice. Impulse traps can be used to drain condensate from steam mains, unit heaters, laundry equipment, sterilizers, and other equipment in which pressure at the trap outlet is 25 percent or less than inlet pressure.

Throttling trap. This trap, illustrated in figure 3-24, operates by the flashing principle.

Condensate flows freely through the trap orifice, motivated by the pressure difference between inlet and outlet, until steam enters the inlet chamber and mixes with the remaining condensate. This reaction heats the condensate and causes it to flash, choking the flow through the orifice and allowing more condensate to accumulate in the trap. This trap has no moving parts and the orifice is adjusted for the pressure differential required. A gage glass shows when the trap is operating. The traps can be used with steam heaters, blast heaters, unit heaters, dryers, evaporators, kitchen and laundry equipment, steam lines, or other equipment in which steam and condensate return pressure differences do not drop below 5 psig.

3. Which trap operates due to a flashing action produced by a pressure drop?
4. Which trap operates due to a pressure difference between the inlet and outlet?
5. Which trap is generally used on radiators?

660. Specify fundamentals of inspecting and repairing a steam trap.

Exercises (659):

1. Name the most common types of traps found in the heating field.
2. Explain the operating functions of each of the following traps:
 - (a) Thermostatic trap.
 - (b) Float trap.
 - (c) Impulse trap.

Operational Maintenance of Steam Traps.
Application of the following procedures will enhance steam trap operation.

Priming. Inverted bucket traps require priming. Before starting operation, remove the test plug on top of the trap and fill it with water. Traps can also be primed by opening the steam supply valve slowly and keeping the trap discharge closed until it is filled with condensate.

Insulation. Keep insulation in good condition at all times. If heat conservation is a major item, insulate traps that are in continuous use. One exception to this is the thermostatic trap, which depends on the cooling effect of the condensate for operation.

Bypass valves. These valves are used during startup to accelerate the discharge of condensate and air. Keep them closed during

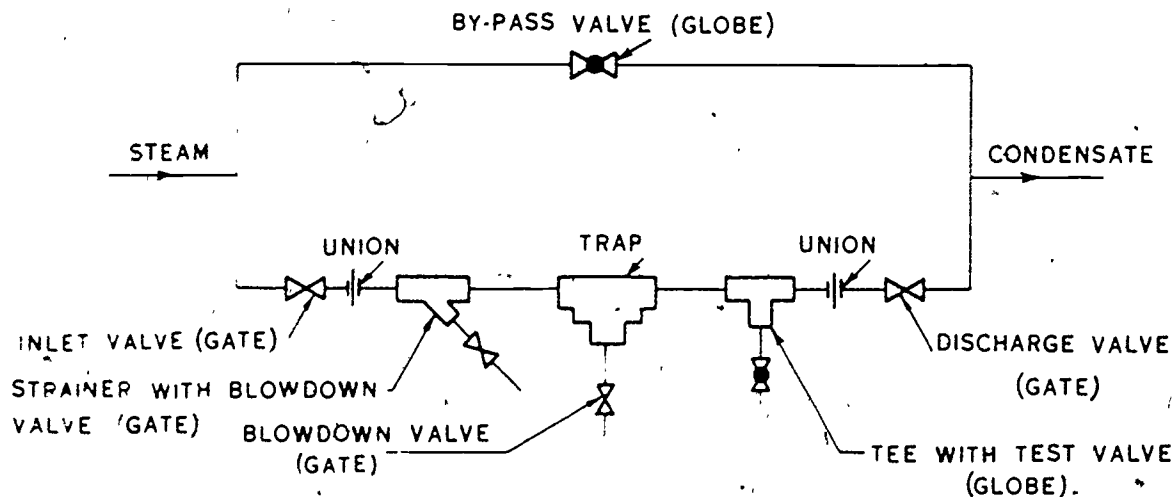
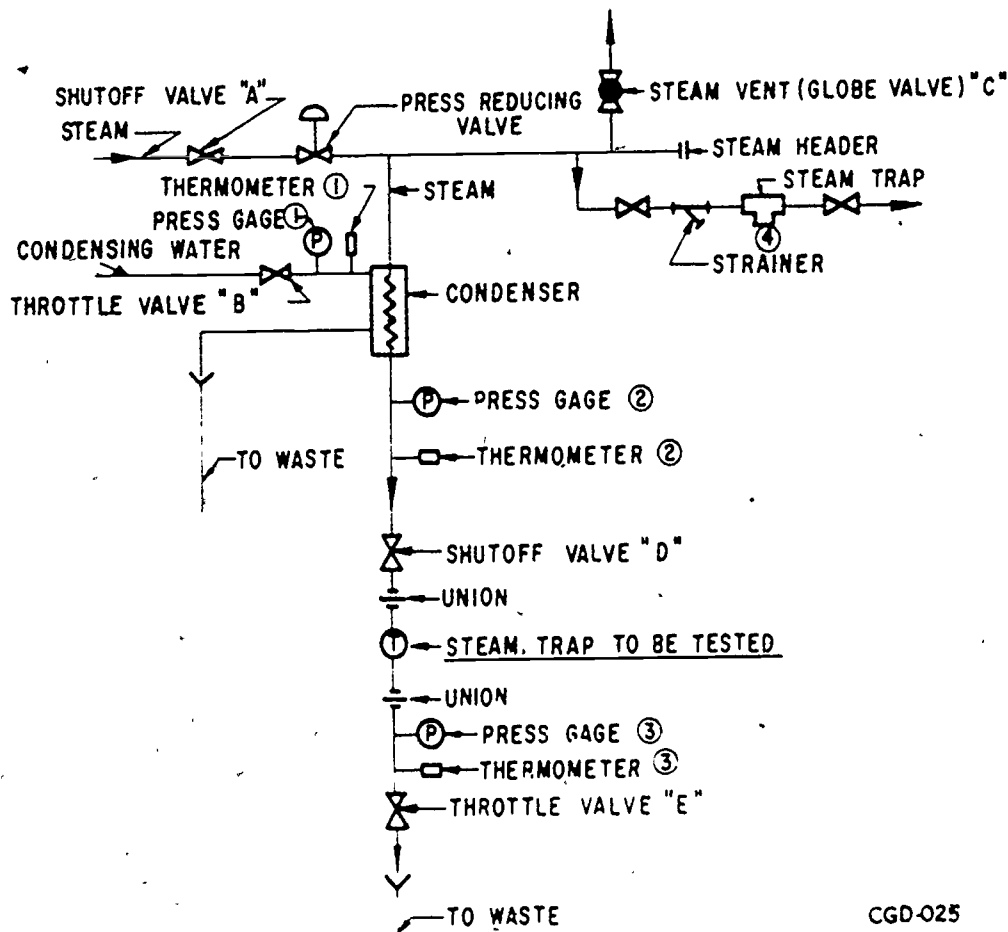


Figure 3-25. Sketch of trap installation.



CGD-025

Figure 3-26. Test rack for trap testing.

normal operation. Figure 3-25 illustrates a common hookup for a trap used in conjunction with a bypass and a strainer. Bypasses are sometimes installed to permit maintenance of traps and strainers without shutting off steam.

Blow down. Blow down steam traps periodically to get rid of dirt accumulations. See figure 3-25 for blowdown application. Do not remove thermostatic elements while they are hot, or they may expand beyond the stroke range of the bellows or diaphragm.

Air vents. Open the air vents on float traps periodically to vent out accumulated air.

Trap Testing, Repairs, and Test Rack. Traps can be tested without breaking the installation by opening the test valve and closing the discharge valve. Intermittent discharge, dribble, or semicontinuous discharge indicate correct operation. A continuous steam flow indicates a defective valve, loss of prime, or foreign matter on valve seat. A continuous condensate flow indicates that the trap is too small, the amount of

condensate drained abnormally high, or the trap inlet pressure abnormally low.

Repairs. Once a year, or more often if required, completely dismantle and clean all steam traps. Inspect for the following: plugging of orifices and vents; corroded, eroded, worn out, or otherwise defective parts; wear, grooving, and wire drawing of valves and seats; defective bellows, buckets, or floats. Replace or repair parts, as required. Use only matched sets of replacement valves and seats. Do not change the weight of floats or buckets when repairing traps or operation may be affected.

Test rack. After repairs, traps can be checked with a test rack, such as that shown in figure 3-26. Actual operating conditions of the steam trap can be simulated by proper manipulation of valves. Use the following procedure to test a trap:

- (1) Make sure that all valves shown in figure 3-26 are closed.
- (2) Connect steam trap to be tested at location (T).

- (3) Open shutoff valve "A."
- (4) Crack open steam vent valve "C."
- (5) Adjust steam pressuer reducing valve to required steam pressure at ②. This should be normal operating pressure at trap inlet.
- (6) Throttle steam vent valve "C" as much as possible without interfering with correct operation of pressure reducing valve.
- (7) Put the steam trap at ④ in service to keep the steam header properly drained.
- (8) Open shutoff valve "D."
- (9) Open throttle valve "E." If the trap is operating correctly, this valve will not discharge condensate when the only steam is at the trap inlet.
- (10) Regulate throttle valve "B" to start circulation of condensing water.
- (11) When steam begins to condense, the steam trap at ① will start discharging condensate.
- (12) Adjust throttle valve "E" to obtain a pressure at ③, which corresponds to normal operating conditions.
- (13) Take temperature and pressure readings at ② and ③. If trap is operating correctly, at each location, temperature should equal or be close to the saturated steam temperature that corresponds to the pressure.

Exercises (660):

- 1. When inspecting a steam trap, you find a continuous steam blow. What would probably be the cause?

- 2. A continuous flow indicates what malfunction of a steam flow?

- 3. What are normally the repair tasks of steam traps?

- 4. When should repairs of traps be scheduled?

- 5. When testing a trap, which valve is regulated to start circulation of condensing water?

661. Cite general valve repair tasks done by heating specialists and state the circumstances that warrant the repair or replacement of valves.

Repair or Replacement of Valves. Many shutoff valves are never operated during normal plant operation. These might be isolation valves, emergency valves originally installed for personnel or equipment safety, bypass valves, etc. But unless such valves are occasionally operated, they may deteriorate with time. Then, when you need them in a hurry, they just don't work. It's a good idea to operate each valve during some idle period just to see that it does actually work. This will help detect trouble before complete failure, save repair costs, and prevent damage to other equipment.

If valve packing is allowed to leak continuously, stem damage may progress to the point where no packing will hold. Then complete stem replacement is necessary. Just because a valve is hard to get at is no excuse for permitting it to continue leaking. A leaking stem frequently means a chattering valve. Chatter initiates other troubles within the valve. Vibration extends to the working parts and can damage them beyond repair. Another trouble that goes with a chattering valve is accidental closing. In a critical application, such as a pump suction line, accidental closing can cause extensive damage.

Many repairs can be made on valves to help restore them to proper operating condition. Among the most common is grinding—this removes small irregularities on the contact surfaces of the seat and disc. Topping is another repair task that removes larger irregularities from the contact surfaces that cannot be removed by grinding. Refacing is the process of refacing (reshaping) badly scarred valve seats.

The easiest repair task and the one that can prevent a valve from being subject to more extensive repair is repacking. If the stem of a valve is in good condition, stuffing box leaks can usually be stopped by setting up on the gland. If this does not stop the leakage, repack the stuffing box. The gland must not be set up on or packed so tightly that the stem binds. If the leak persists, a bent or scarred valve stem may be the cause of the trouble.

Coils (strings) and rings are the common forms of packing used in valves. The form to be used in repacking a particular valve depends in part on the size of the packing that is required. In general, rings are used in valves that require packing larger than one-fourth



inch. When a smaller size of packing is required, string packing is generally used.

To repack a stuffing box, place successive turns of the packing material around the valve stem. If you are using string packing, coil it around the valve stem and level off the ends to make a smooth seating for the bottom of the gland. Then put on the gland and set up on the gland nut. To keep string packing from folding back when the gland is tightened, wind the packing in the direction in which the gland nut is to be turned. When using ring packing, be sure that the joints of the successive rings are staggered.

Exercises (661):

1. Which repair task maintains valves and is the most economical?
2. Which methods of repair are normally available to heating personnel in valve maintenance?
3. State discrepancies that warrant valve repair.

662. Cite the major requirements in checking the alignment, packing, and lubrication of an expansion joint in a steam heating system.

Inspection and Maintenance of Expansion Joints. Expansion joints were partially covered in Chapter 1 of this volume. The following information pertains to the inspection and maintenance of expansion joints.

Slip type. Slip-type joints must be kept properly aligned, adequately packed, within the proper limit of travel, and thoroughly cleaned and lubricated. Adjust or replace packing, as required, to prevent leaks and assure a free working joint. Lubricate every 6 months, using the proper grease for the type of joint and service conditions. Once a year, check the flange-to-flange distance of slip joints, first when cold and then when hot, to make sure that travel is within the limits shown in the manufacturer's data. A change in slip travel usually indicates a shift in anchorage or pipe guide. Locate and correct the difficulty. Also, inspect annually for signs of erosion, corrosion, wear, deposits, and

binding. Repair or replace defective parts, as required.

Bellows type. Annually, check bellows joints for misalignment, fatigue, corrosion, and erosion; note the amount of travel between cold and hot conditions. If the joint fails, replace the bellows section.

Expansion loops. Expansion loops require no specific maintenance except inspection for alignment.

Ball joints. See that joint is adequately packed. Adjust or replace gaskets, as required, to prevent leaks and obtain a free working joint. Refer to manufacturer's instructions.

Swing joints. These joints require only the normal maintenance for pipe and fittings.

Exercises (662):

1. How often should you lubricate a slip joint?
2. What do you inspect most slip type joints for?
3. What do you inspect expansion loops for?
4. How often are most bellows-type joints completely inspected?
5. What does checking and maintaining packing correctly do for an expansion joint?

663. Specify the procedures for inspecting steam line conduits for leaks, deterioration, and security.

Inspecting and Servicing Conduits. The various conduit systems were covered in Chapter 1, this volume. The following discussion outlines the basics of inspecting steam conduits.

Tunnels, trenches, and tile conduits. Once a month, inspect manholes for operation of sump pumps and steam ejectors. Once a year, after the heating season or sooner, if necessary, completely overhaul sump pumps and steam ejectors.

Ventilation of tunnels. Tunnels in which heating lines are located are often ventilated. Ventilation increases the comfort of workmen making repairs and removes dangerous gases which might tend to accumulate. (There have been instances in which workers in tunnels have been suffocated by collected carbon monoxide from automobile engines.) There are two main ventilation methods:

a. Exhaust fans. Exhaust fans located at the plant provide a draft in the tunnel. Air enters the manhole, circulates through the tunnel, and is discharged by the fan to the atmosphere.

b. Ventilating fans. Ventilating fans are located in manholes. They are so arranged that they can either exhaust air from or force air into the manhole.

Metallic casings (class A systems). A leaking carrier pipe or entrance of ground water through the conduit may result in soaking the insulation. Therefore, only class A (pressure testable) systems are acceptable for Air Force work in areas having high water tables. These systems are provided with end seals, vents, and drains at terminal points.

Class A systems have seals and telltales at manholes and building entrances. Packed gland-type conduit seals are used when provisions have been made for longitudinal movement of the pipe. If the pipe is anchored at manholes and building entrances, end-type seals should be used. Telltales and drain plugs for conduit seals should have a 1-inch minimum diameter and be located at the top and bottom of the vertical centerline of the seal plate. Telltale and drain plugs should have an unobstructed passage to the airspace between the insulation and the conduit walls. Weekly, check telltales for leaks; their presence will be indicated by the discharge of steam through the telltales.

When drying insulation, follow definite procedures. First, drain water accumulations through the conduit drains, then circulate air under pressure through the airspace in the conduit, using conveniently located vents to dry the insulation. Place a cool mirror at the exhaust point for a short time at appropriate intervals, positioning it to indicate maximum clouding due to moisture. Dry insulation, while heating lines are operating, for at least 48 hours and until no clouding shows on the mirror. Limit maximum ventilation rate to that which develops an air pressure of 15 psig at the inlet end, or achieves an average air linear velocity of 500 fpm in the airspace, or to just below that which would damage the insulation by impact or erosion, whichever is

reached first. To determine average air velocity, divide the cfm at atmospheric pressure by the area (taken in a plane at right angles to the centerline of the pipe) of the ventilated air passages.

Pressure tests of conduits are made to detect leaks or defects. With the system dry and heating lines in operation, apply air pressure to the conduit cavity until 15 psig is obtained. Maintain this pressure constant for two consecutive hours without adding air to the cavity. If the air pressure does not hold, check for leaks in the conduit or defects in the membrane or sealants. Soap all accessible joints. If air is leaking from the soaped joints, a bubbling effect will be produced.

The *odorization test* is made if leaks are known or suspected to exist. To conduct the test, close all drains and all vents except one. Through the open vent, inject properly odorized air, under pressure, into the cavity. Leaks can be located by the odor of the escaping air.

Systems other than class A. If conduit leakage is suspected, proceed as follows before putting the line back in service.

Drain all water from conduits, turn on the steam or high temperature water to raise the temperature of the line. This will evaporate the moisture in the conduit.

In emergencies, if necessary to prevent buildup of excessive steam pressure in the conduit space and a resultant failure of conduit or sealing strip, dig down to the conduit or one of the sealing strips and make a temporary vent until conduit repairs can be made.

The procedure for *drying* this insulation is analogous to that described before. However, limit the maximum rate of ventilation for class B systems to one that develops a pressure of 12 inches water gage anywhere in the airspace, results in an average air linear velocity of 500 fpm in the conduit airspace, or which is just below that which would damage the insulation by impact or erosion, whichever comes first. The average air velocity is determined in the manner as stated above.

Preventive maintenance inspection of manholes. Clean and inspect manholes quarterly. Check roof slab, frame and cover, walls, and floor for deterioration. Check manhole drain, sump pit, and sewer connection. Inspect ladders; make sure that vents are unobstructed, check condition of conduit seals, telltales, and drain plugs.

Maintenance of manholes. Make repairs indicated by inspections. Stop water leaks in the floor and walls. For concrete

construction, use a cold chisel and hammer to chip out the porous area so that the patch will bond against sound concrete. Then plug the hole or crack with a calcium chloride mixture or quick-setting cement mortar.

Exercises (663):

1. How is the location of suspected leaks tested in class A conduits?
2. Explain the pressure testing of class A conduits.
3. When checking manholes, where and what do you inspect for deterioration?
4. How often are telltales checked for leaks?
5. When circulating air under pressure through airspaces in the conduit, how is the average air velocity determined?

664. Cite the types, uses, and installation fundamentals of preformed insulation.

Insulation is any type of material that has high resistance to heat flow. It is used to help prevent heat loss. Insulating brick is the form of insulation placed in the firebox of a furnace to minimize the escape of heat through firebox walls. Sheet insulation is used to cover the outside of boilers, furnaces, and air ducts to reduce heat loss. Tube insulation is installed on distribution lines so that an excessive amount of heat is not lost from the heating media while going to the radiators. Insulation is also placed on return lines so that the condensate will not freeze before it returns to the boiler. By preventing heat loss, less fuel is needed to supply the demands for heat. Insulation for heating systems should be fireproof, be verminproof, have lasting quality, be mechanically strong, be compact, and be light in weight.

The insulation used by the Air Force on heating units can be procured in a variety of forms—such as powdered, sheet, block,

blanket, tube, and roll. Powdered insulation is usually mixed with water and used to cover odd shapes—such as pipe unions, elbows, and valves. Sheet insulation is used to cover warm air and cold air ducts, as well as the walls and ceilings of furnace rooms. Block and brick insulation materials are most often used to insulate the outside surfaces of boilers. Blanket insulation is used to cover the warm air and cold air ducts in a warm air heating system. It is also used to cover the cold and hot water pipes in a steam or a hot water heating system. Tube insulation, such as asbestos paper, is used to cover cold and warm air ducts for furnace casings in hot air heating systems.

Magnesium asbestos insulation is the most common type used to cover heating equipment. Other insulating materials, such as rock wool, hair felt, glass wool, and fire felt are also used to a limited degree in Air Force heating installations.

Types of Insulation. The various types of insulation in common use and their applications are explained in the following paragraphs of this section.

Powdered insulation. Powdered insulation is procured in 25-, 50-, and 100-pound bags. It is mixed with water to prepare it for application. Usually, four parts of insulation to one part of water, by volume, will give a mixture of sticky consistency. The prepared insulation is applied to odd-shaped areas, such as elbows and unions, and compressed by hand until the excess moisture is removed from it. The insulation is then covered with cheesecloth or canvas, which has been saturated with plastic asbestos cement. This covering should then be allowed to dry thoroughly before the area is heated.

Sheet insulation. Sheet insulation can be procured in various sizes and thicknesses. Sheet insulation is usually applied to flat areas, such as ducts, boilerroom walls, and ceilings, since it will not bend. Insulation of this type can be wired, screwed, nailed, or pasted in place.

Block insulation. Block insulation held with plastic asbestos cement is normally used to cover the outside surfaces of boilers. When boilers are being insulated, the insulating value can be increased by first covering the boiler with ribbed metal. This procedure provides a dead air space next to the boiler and gives higher insulating results than the use of the insulation alone. The application of ribbed metal to a boiler is illustrated in figure 3-27. After the boiler has been covered with ribbed metal, the block asbestos is applied.

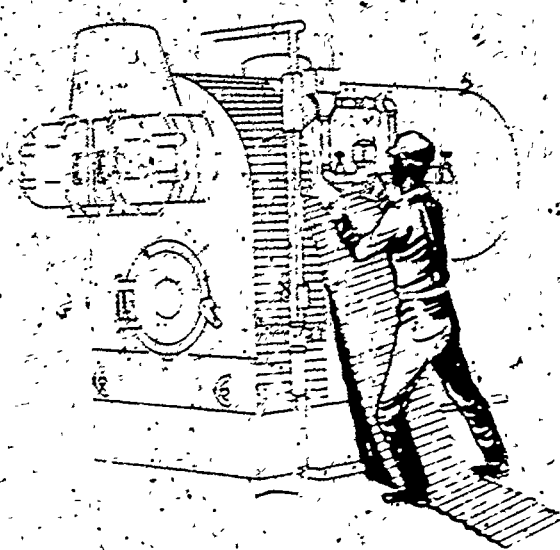


Figure 3-27. Applying ribbed metal to a boiler.

Several wires are passed loosely and vertically around the boiler shell (about 30 inches apart); then the insulating blocks are slipped under the wire and positioned with their edges closely butted together. Application of the blocks is started at the bottom and laid up on the sides. If the blocks do not come out evenly at the top, the spaces are filled in with small fitted pieces of block. After this, the wires are drawn tight, and other wires are then installed at about 6-inch intervals until the blocks are wired securely in place. Three or four more wires are passed horizontally around the bottom of the firebox so that they are below the rivet heads or other projections which will prevent them from slipping up. The wires are twisted into a cable and thus drawn tightly around the firebox. Several lacing wires can then be run over parts of the boiler shell above the firebox and wired to the cable around the firebox. Sufficient lacing wires should be added to insure that the blocks will be held firmly in place, crossing and tying the wires, as necessary.

When the asbestos blocks are wired in place, the boiler is covered with 1½-inch hexagonal galvanized wire netting (poultry netting). Openings are cut in the netting wherever necessary. When the openings in the wire netting tend to spread, wire is laced through the meshes of the netting around the opening to draw the meshes together. This makes the wire netting conform to the shape of the opening in the boiler.

The asbestos cement should be mixed in a

tub or a large container, only enough water being used to make the cement workable. Best results can be obtained by thoroughly mixing the cement and applying it to the boiler when the boiler is hot.

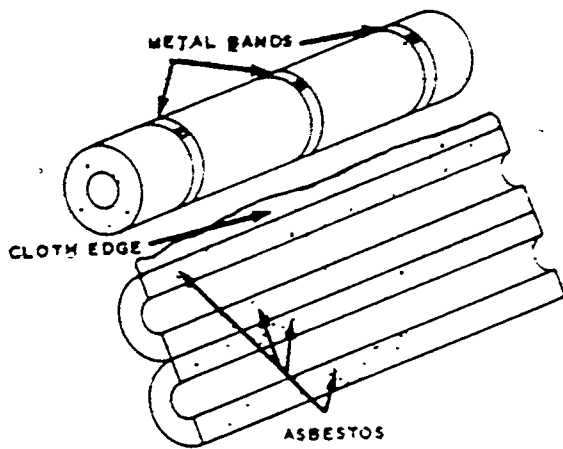
The asbestos cement may be applied in one coat or two coats. If one coat is applied, the coating should be about 1½ inches thick. If two coats are applied, each coat should be about ¾-inch thick. Usually, when the cement is applied in one thick coating, it has a tendency to fall off before it dries. Actually, for the inexperienced boiler operator, it is better to apply the cement in two coats. When applying two coats, take care to roughen the first coat with a trowel and allow it to dry thoroughly before the second coat is applied.

A canvas jacket is not always used to cover heating units. However, the protection afforded by it will prevent the insulation from crumbling. A heavyweight canvas (preferably 8 ounce) is recommended for this purpose. Large pieces should be used to avoid making joints and laps. However, when joints are made, the canvas should overlap about 2 inches.

The canvas should first be applied on the ends, turning the edges back over the sides. If it is installed in this manner, the canvas that is applied to the sides will lap over the first canvas applied to form a neat edge. The canvas is first dipped in cold water paste and wrung out by hand. Then it is spread neatly and smoothly over the surface of the insulated boiler. The canvas should not be applied closer to heated metal surfaces than one-fourth inch.

When canvas is to be fitted around openings, it should be cut after it has been dipped in the paste. Care is taken not to cut the openings too large. The edges can be trimmed neatly when the canvas is being pasted and smoothed into place. Short slits are cut in the edges of the canvas around the openings to permit the canvas to lie smoothly when it is turned back on beveled edges. When the canvas is thoroughly dry, two coats of good oil paint or sealer should be applied if the covering needs waterproofing.

Another type of block insulation is the high temperature type used to form the lining in the firebox of a boiler. High temperature block insulation is composed of uncalcined diatomaceous earth mixed with asbestos fiber. These blocks should not be used where they will come in direct contact with the flame. They are usually protected by regular refractory firebrick and are laid in the same manner.



CCL-010

Figure 3-28 Tube insulation.

Blanket insulation. Blanket insulation is another form of insulation used to cover warm air heating ducts and steam and hot water pipes. The insulation is usually composed of minute glass fibers. It resists fire, corrosion, vibration, settling, and the effects of humidity. The glass fibers are inorganic, they provide no sustenance for fungus or bacteria, and no food for rodents or insects. Its lightness, flexibility, and resilience make it easy to handle in large sections and easy to place properly. It is simple to cut with a knife or shears, and it can be bent around curved surfaces and easily fitted into irregular areas. To install blanket insulation, you glue it with asbestos cement, cover it with cloth, or clamp it with metal bands.

Tube insulation. Tube insulation is made in the form of a tube, as illustrated in figure 3-28, to fit around the various sizes of piping. The insulation for piping systems is made slightly different from that used on boilers. Tube insulation can be procured in various lengths. If the insulation can be cut conveniently on the job, only long lengths should be procured. However, if the composition of the tubing insulation does not permit easy cutting, then various lengths should be obtained. Usually, tube insulation is split in half and covered with a layer of cloth which can be opened somewhat like a hinge, as shown in figure 3-28.

After the tube insulation is placed on the pipe, asbestos cement is applied to the loose edge of the cloth. The cloth is then pulled tightly around the insulation. After drying, the paste holds the cloth and insulation in place. Metal bands are placed at frequent

intervals around the insulation for added strength.

When insulated pipe is outside where it will be exposed to the weather, the insulation should be covered with tar paper. Then, the tar paper should be given a coating of melted tar to provide additional waterproofing quality and to hold the paper in place.

Roll insulation. Roll insulation, commonly referred to as asbestos paper, is procured in rolls of various widths. Roll insulation should be applied to reasonably flat areas, such as square or round air ducts and casings of furnaces. The insulation is applied by pasting it to the surfaces with asbestos cement or other appropriate cement.

Insulation that is installed must be properly maintained to provide effectively its insulating qualities. Therefore, the next discussion is centered around maintaining insulation.

Maintaining Insulation. It is necessary to repair all breaks and cracks in the insulation. Corners or exposed edges of insulation should be protected by installing iron guards. All insulation must be protected from moving parts which can mar, puncture, or damage it. Insulation must be protected from excessive pressures. Ladders, plants, piping, iron bars, etc., should never be allowed to rest on the insulation installed on a boiler or piping. One should never step or walk on insulation. The insulation around the pipes in dining halls can be protected with a sheet metal sleeve.

Exercises (664):

1. Cite the types of insulation.
2. Identify the uses of each type of insulation.
3. Cite the normal application procedure for preformed insulation.
4. State the ratio of mixture and water and describe the manner of applying powdered insulation.
5. How is plastic asbestos cement mixed and applied?

- 6. Why are ducts covered?
- 7. How is the insulation used on ducts held in place?
- 8. What type of insulation is used on ducts?
- 9. How are corners or exposed edges of insulation protected?

665. List the components, identify the purpose, and describe the procedures involved in maintaining a pressure reducing station.

Pressure Reducing Stations. When steam is drawn from a high pressure line to heat buildings or water, or for process work, reduce its pressure to the working pressure of the system with a pressure reducing station. A pressure reducing station consists of various types of valves and strainers, which are discussed in the following paragraphs.

Pressure reducing valve. This is the first or primary valve of the pressure reducing station; its purpose is to reduce the steam pressure to or below the maximum allowable working pressure of the equipment served. It can be either pilot-operated or direct-acting, single-seated or double-seated, spring-loaded or weight-and-lever operated.

Pressure regulating valve. This is the secondary valve; it controls and maintains the optimum pressure required by the steam-consuming equipment. Pressure regulating valves are of the same types as reducing valves.

Relief valve. This valve protects low pressure lines and steam-consuming equipment from overpressure, if the pressure reducing valve fails.

Strainer. Strainers are installed ahead of pressure reducing or pressure regulating valves to prevent the passage of loose dirt, rust, scale, or other loose foreign material which would interfere with the proper operation of the equipment.

Auxiliary valves. Install the isolating gate valves needed to remove pressure reducing and regulating valves from service. When a continuous supply of steam is required, and in large installations, install bypass valves around

the pressure reducing and regulating valves. Use globe-type bypass valves one-half the size of the pressure reducing or regulating valve to permit manual regulation.

Pressure gage. Install a steam pressure gage on the low pressure side to facilitate supervision of pressure reducing station operation.

Installation. When making a two-stage reduction, increase the pipe size to allow for expansion of steam on the low pressure side of the valve. The larger pipe size allows steam to flow at a more uniform velocity. The valves should be separated by a distance of 20 feet to reduce excessive hunting action of the first valve. In general, if the steam distribution pressure exceeds 50 psi, a pressure reducing valve should be installed near the connection between the main distribution line and the consumer system, followed by a pressure regulating valve and a relief valve. When distribution pressures are below 50 psi, the pressure regulating valve may be omitted.

Dual Valve Installations for Seasonal Variations. In relatively large installations where substantial seasonal variations in steam demand are likely to occur, a dual valve installation is commonly used. This device consists of the parallel installation of two reducing valves of different sizes, with capacities that range from about 70 percent to 30 percent of maximum steam requirements. Thus, if 60,000 pounds of steam per hour are required, the larger valve would be sized on the basis of $0.70 \times 60,000$ pounds, or 42,000 pounds per hour; the smaller one, on the basis of $0.30 \times 60,000$ pounds, or 18,000 pounds per hour. The purpose of the installation is to prevent wiredrawing of the seats and discs of large reducing valves when they operate at very low loads.

Summer season operation. The smaller valve is set to control at the desired reduced pressure and the larger valve at a somewhat lower pressure. Normally, steam will flow through the smaller valve only.

Winter season operation. The larger valve is set to maintain the desired reduced pressure and the smaller one to control at a slightly lower pressure. When steam requirements are within the capacity of the larger valve, the steam will flow through this valve only; the smaller valve will remain closed. If steam requirements exceed the capacity of the larger valve, the controlled pressure will drop and the smaller valve will also open. Steam will flow through both valves to supply the load.

Maintenance. The following paragraphs

specify maintenance fundamentals of pressure reducing stations

Pressure reducing valves Repair or replace defective parts, as required, after the yearly inspection. Examine valve stem, replace or metalize, if necessary. Change or regrind valve and seat, as required. Change valve to smaller size if excessive cutting indicates an oversize valve. Repack stuffing box. Observe condition of bellows, diaphragms, etc.

Relief valve Once a year, or more often if required, dismantle the valve and look for damaged seats, foreign matter between the seat and feather, defective parts, distortion caused by uneven strain on the flange bolts or improper installation of exhaust piping, erosion, corrosion, wear, and deposits of foreign matter. Correct conditions, as requires.

Strainers Clean and repair or replace defective strainer baskets and gaskets, as required. Mesh baskets can sometimes be repaired by soldering on a patch of wire cloth of the same or a finer mesh.

Auxiliary valves and pressure gages. Maintenance procedures have been covered for these fittings earlier in this course.

Exercises (665):

1. What is the function of a pressure reducing station?
2. List the main components of a pressure reducing station.
3. Specify the function of the components in a pressure reducing station.
4. Describe basic maintenance steps performed on pressure reducing stations.

3-4. Boiler Layup

Serious corrosion can take place in a sound boiler even when idle. The corrosion is caused by oxygen dissolved in the water. If the boiler is not completely drained, oxygen dissolved in small pools of water in the boiler may cause concentrated, localized corrosion. It is not always possible to eliminate air, which

461
contains oxygen, from the boiler. It is possible, however, to dry the boiler and follow procedures which will insure that moisture will not again form on exposed metal surfaces. Out-of-service boilers may often be required to resume operation in 4 to 6 hours. Under these conditions, it is not practicable to drain the water from the boiler. Unless the boiler is sealed and contains water, there will not be time to meet the steam demand. For this situation, an alternate method of boiler layup is recommended that protects the boiler metal and maintains the boiler in a standby condition.

666. Cite the fundamental methods and procedures of laying up a boiler.

Boiler Layup Fundamentals. Idle boilers can be laid up by the dry storage or the wet storage method.

Dry storage. This method is preferred for prolonged outages and freezing temperatures. Proceed as outlined in the following paragraphs.

Thoroughly clean and dry unit, externally and internally. Place wooden trays of quicklime (2 pounds per 1000-gallon boiler capacity) inside the drums. In moist atmospheres, it is wise to place trays in the furnace also. Silica gel (10 pounds per 1000-gallon boiler capacity) may be substituted for the quicklime to absorb moisture from the air. Fill trays only about three-fourths full. This will prevent overflow of liquid after moisture has been absorbed.

Tightly close all manholes, handholes, access doors, and observation doors. See that all connections to the boiler are tightly blanked to prevent entrance of moisture from any source.

Inspect the unit monthly to be sure desiccant and absorbent are effective and not loaded with moisture. Replace the absorbent material, as required.

Wet storage. This method is preferred for boilers that are in standby conditions for short periods of time and may be needed for service on short notice. Do not use it if freezing temperatures can be expected. Use the procedures outlined in the following discussion.

Close the boiler when it is clean and empty, and fill it until the water overflows through the drum vent or through the superheater vent in superheater installations. While the boiler is being filled, continuously feed caustic soda and sodium sulfite into it. If this is not possible, use a circulating pump to

462

uniformly distribute chemically treated water throughout the boiler.

Maintain boiler water concentration of 200-450 parts per million (ppm) of caustic soda and about 100-200 ppm of sodium sulfite.

After shutting off the overflow from the vent, maintain a water pressure in the boiler of 10 to 15 psig during storage.

Weekly, analyze water samples to find if required water concentration is maintained. If the causticity or sulfite has dropped below minimum levels, feed additional chemicals and circulate the boiler water to distribute it uniformly.

Serious corrosion can take place in a sound boiler while it is idle.

Corrosion causes. If a boiler is left idle without filling with water, air enters when the pressure drops and oxygen dissolves in the water. The oxygen-saturated water may then cause active corrosion and pitting, particularly at the waterline. Then, if moisture in the boiler condenses to form water droplets on the boiler surface above the waterline, pitting can occur because the droplets are saturated with oxygen and contain no causticity. Much of the corrosion in the types of boilers discussed in this volume occurs because the boiler is not properly protected during idle periods.

Layup methods. As we have stated, there are two principal ways to lay up idle boilers: the wet method and the dry. The wet method is usually considered more suitable for a boiler left idle for a short period (a month or less) or when unexpected demands for steam may occur, because it permits the boiler to be put back into operation more quickly. For longer idle periods (three or more months), the dry method is usually considered more desirable because it requires less care and control. If the entire plant is laid up and freezing weather is anticipated, do not use the wet method.

Boilers operated for intermittent short periods. When a boiler is operated for brief periods (such as for one shift daily) and otherwise left idle and under no pressure, it may be necessary to keep it filled to the normal operating water level. Unless preventive measures are taken, corrosion and pitting may occur. Corrosion will be light if the boiler is coal-fired and the pressure drops so slowly that little air is sucked into the boiler. But in oil-fired boilers, considerable corrosion can occur. To control this corrosion, take the usual precautions about causticity and deaeration. If equipment for deaerating feedwater is not installed, prevent

leakage of air into the system as much as possible. Keep the boiler closed when it is idle and cool, and treat boiler water with tannin, maintaining a darker brown color than normal.

Exercises (666):

1. Name the methods of boiler layup.
2. What is used in the dry layup? What is the amount of the ingredients?
3. Cite the tasks involved in the dry layup method.
4. What is used in the wet method and what is the concentration?
5. Specify tasks involved in the wet method of boiler layup.

667. Specify the tasks involved in filling and leak testing a boiler.

Filling and Leak Testing Boiler. The subsequent procedures should be followed when preparing to fill a boiler.

Close the following valves: all blowdown valves, chemical feed valves, boiler drains, water column and gage glass drains, feedwater regulator drains, boiler nonreturn, man stop, soot blower header (steam system); all soot blowers, all burner fuel valves, and auxiliary valves, as necessary.

Open the following valves: vents on boiler drums and superheaters, if present; drains on superheater, if provided; recirculating line valves in economizer, if present; feedwater stop and check, water column connections, gage glass valves; pressure gage steam drum connection and petcock, and auxiliary valves, as necessary.

Fill the boiler slowly with properly treated water at a temperature of 70° F. to 100° F. The temperature difference between the water and the pressure parts of the boiler should never be greater than 50° F., otherwise

severe temperature stresses could be set up. Fill the boiler to just below the middle of the glass on the water column.

After filling the boiler with water, all major leaks should appear such as loose fittings, handholes, manholes, etc. Normally, leaks will not appear till after the boiler has been lighted off and the firing rate has been adjusted to raise the water from room temperature to the boiling point (212° F.) in about 90 minutes. After the boiler has reached a pressure of approximately 15 psi, close the drum vent and check for leaking gasket joints. If a leaking gasket is found, shut down the boiler, drop pressure, and tighten the joint. After the boiler is started up again and if the gasket still leaks, shut down the boiler, drop pressure, and completely replace the gasket. Repeat these tasks until all leaks have been detected and repaired before commencing with normal operation.

Exercises (667):

1. What should the temperature be when filling a boiler?
2. How much water should be put in a boiler when filling?
3. Where are the leaks normally detected when initially filling a boiler, after a major repair?
4. Explain how a boiler is inspected for leaks.

3-5. Boiler Inspections

Steam boilers operating above 15 psig and high temperature water heating boilers will be inspected by qualified boiler inspectors. These inspectors inspect boilers, accessories, and piping to determine the condition of the boilers and safety devices, and to determine that boilers and safety devices are suitable for safe operation. Inspection of HTW boilers includes inspection of the expansion drum as well as the water tube headers, furnace, and safety valves.

There are certain exemptions from this inspection, such as: steam boilers with safety

463
valves set at 15 psig or less, hot water boilers with safety valves set below 160 psig, pressure vessels not directly heated by water, and pressure vessels of less than 1 horsepower.

668. Identify and describe the types of boiler inspections.

The Defense Supply Agency, Defense Contract Services District, Cincinnati, administers contracts each year for the services of a qualified company to provide boiler inspections at all Air Force bases within the continental United States (excluding Alaska and Hawaii). For many years, the Hartford Steam Boiler Inspection and Insurance Company, Hartford, Connecticut, has provided the service of inspecting all steam boilers over 15 psig and the high temperature water boiler.

Special inspections (outside the scope of the contract required by these instructions or considered necessary by major commands or base civil engineers) may be arranged through the Defense Supply Agency, Defense Contract Administration Services District, Cincinnati.

If the company under contract to furnish boiler inspection service cannot make a special or emergency inspection, the base civil engineer may hire a recognized insurance company or a boiler inspection agency that specializes in such work. (An installation employee may not make such special inspections.)

Types of Boiler Inspections. The contract will provide the following five types of inspections when they are excluded in the annual schedule submitted by the major command:

Type A - Internal and external inspection.

Type B - Internal and external inspection, followed or preceded by external inspection while boiler is under hydrostatic test.

Type C - External inspection while under steam pressure or filled with water. (Boiler will be under pressure for this inspection.)

Type D - External inspection while under hydrostatic test.

Type E - Internal and external inspection of expansion tanks used with high temperature water boilers.

Overseas and other off-continent commands are authorized to employ qualified and competent boiler inspectors to perform the inspections covered above (types A through E). These inspectors will not be supervised by personnel at base level. They will prepare AF Form 1222, Boiler Inspection Report, on each boiler inspected and submit

464

it to the Director of Civil Engineering of the appropriate major command. Detailed comments on these reports will be made by an attached memorandum.

The boiler inspector will make the types of inspections requested in the annual schedule submitted by the major command to the Defense Supply Agency, Defense Contract Administration Services District, Cincinnati. If an inspector determines that an additional inspection is necessary, the base civil engineer will authorize him to perform it before he leaves the base. However, such additional inspection will not constitute authority to delete subsequent scheduled inspections. The following inspections are required as a minimum:

(1) Steam boilers assembled on the site: a type B inspection before they are placed in initial operation. (AFM 85-15. Coal Handling, gives instructions for boilers installed under direction of the Corps of Engineers.)

(2) Steam Boilers assembled at place of manufacture and stamped with approval of a qualified inspection agency (such as the Hartford Steam Boiler Inspection and Insurance Company): a type B inspection, after manufacture and before being placed in initial operation.

(3) All steam boilers: twice annually, 2 type A inspection first, and approximately 6 months later, a type C inspection.

(4) Steam boilers in questionable condition; used boilers reinstalled; boilers that have had major repairs, recommended by the boiler inspector or required by the base civil engineer: a type B inspection before being placed in service.

(5) New HTW (high temperature water) boiler installations: a type B inspection before operation.

(6) Other HTW boilers: a type A inspection annually.

(7) Expansion tanks: a type E inspection annually.

Boilers Out of Operation. Boilers out of operation indefinitely need not be inspected by the inspecting agency. However, they should be inspected annually by base civil engineer personnel to evaluate visible deterioration and renew protection against corrosion, if necessary. Also, a boiler that has missed an inspection period must be given the appropriate inspection, as stated, above, before it is placed in operation again.

The hydrostatic pressure used during a type B or type D inspection will be $1\frac{1}{2}$ times the pressure setting of the safety valves. If the safety valve setting has been lowered, it will

not be raised without the approval of the boiler inspector. Boiler inspectors will insure that the boiler, accessories, and adjacent piping are in condition to be operated at pressures up to the safety valve settings.

Exercises (668):

1. What are the classifications of boiler inspections?
2. What does each type of inspection consist of?
3. When is each type of inspection required and for what system?

669. Describe the process of preparing a boiler for inspection.

Preparation for Boiler Inspection. NOTE: These preparations must be made before the boiler inspector arrives on the base.

Provide a hand pump for the hydrostatic pressure test if the boiler feed pump will not deliver $1\frac{1}{2}$ times the pressure at which any safety valve is set.

Make sure that fire surfaces of boilers are reasonably clean. Use a tube brush to remove soot from tubes, and a wire brush to remove soot from the tube sheets and firebox. If the installation burns coal, remove the grate bars, and clean the firebox plates along the grate line until the bare metal is exposed. Take care not to damage metal with sharp tools.

Provide gags to prevent safety valves from lifting when hydrostatic pressure is applied. If hydrostatic pressure tests on more than one boiler are contemplated, provide sufficient gags for all safety valves of the boilers to be tested.

Permit boilers taken off line for inspection purposes (including firebox and settings) to cool before they are drained. Immediately after draining, wash them thoroughly on the inside to prevent sludge deposits on internal surfaces, and remove all suspended solids, sediment, and loose scale.

Fill boilers scheduled for hydrostatic pressure test with water at a temperature between 70° F. and 100° F.; apply a preliminary pressure of 15 to 20 pounds less

than working pressure to insure that all test equipment is in proper working condition.

If the boiler to be tested is on a common header with a second boiler and the latter is to be kept in operation throughout the test, equip the steam pipe between the two boilers with two valves and a drain or a blind joint.

Have available a supply of gaskets for manholes and handholes, and suitable wrenches for removing manhole and handhole covers.

Replace damaged and improper fusible plugs.

If insulation conceals manufacturer's inscribed data, remove the lagging and clean the surface carefully so that die-cut letters and figures can be read easily.

Assign a qualified boiler plant operator to assist the inspector throughout the tests.

If boiler gages and controls are not designed for a pressure equal to the pressure of the proposed tests, remove them and plug the openings, unless cutoff valves are present.

Exercises (669):

1. Describe the fundamentals of preparing a boiler for inspection.

670. Cite the main procedures and inspections involved in performing a hydrostatic test on a boiler.

Hydrostatic Test of Boilers. Before performing a hydrostatic test, rinse out the boiler with fresh water. Examine the boiler carefully for loose scale, dirt, and other objects. Remake all joints, being sure that the gaskets and the seating surfaces are clean. Replace the handhole and manhole plates and close up the boiler.

Gag all safety valves. Boiler safety valves must NEVER, under any circumstances, be lifted by hydrostatic pressure. When gagging the safety valves, do not set up the gags too tightly, or you may bend the valve stems. As a rule, the gags should be set up only hand tight. If no gags are available, the safety valves should be removed and plugs inserted.

Close all connections to the boiler except to air vents, the pressure gages, and the valves of the line through which water is to be pumped to the boiler. Be sure the steam stop valves are completely closed and that there will be no leakage of water through them.

465

After all preparations have been made, fill the boiler with water at a temperature between 70° F. and 100° F. After all air is expelled from the boiler, close the air vents and apply a preliminary pressure of 15 to 20 pounds less than working pressure. This insures that all test equipment is in proper working condition.

Use either the feed pumps or a hand pump, if necessary, and raise pressure to desired limits (1½ times the safety valve setting). In either case, be very careful that you do not exceed the specified test pressure. After the boiler is full, it takes very little pumping to build up quite a pressure.

When the hydrostatic pressure is being built up, the boiler should be given a very careful check for signs of strains or deformation. If there are any signs of permanent (or probable permanent) deformation, stop the test and make necessary repairs.

Check the pressure drop over a period of time. If all valves have been closed, the maximum pressure drop should be 1.5 percent of the test pressure over a period of 1 hour. If there is an excessive pressure drop when there is only a slight leakage at handholes, manholes, and tube joints, the loss of pressure is almost certainly caused by leakage through the valves and fittings. Valves and fittings should be overhauled and made tight.

Exercises (670):

1. How much pressure would you apply for a hydrostatic test?
2. What is the boiler inspected for while under pressure?
3. What should you do if pressure can't be maintained?
4. What procedures do you take to insure the hydrostatic pressure is not released prematurely?

671. State the requirements for a generator and expansion tank hydrostatic test and describe the main procedures of inspection, scheduling, and reporting.

Inspection, Scheduling, and Reporting Hydrostatic Test. Though this subject was partially covered earlier in the text, you will study additional information in this lesson.

A mandatory hydrostatic test is required of all high temperature water boilers (not domestic water heaters) including the expansion drum. For new HTW (high temperature water) installations, a type B inspection is required before operation. On all other HTW boilers, a type A inspection is required annually; and on the expansion tanks, a type E inspection is required annually.

Scheduling inspections. The following information pertains both to HTW installations and steam installations. In the continental US, the Defense Supply Agency, Defense Contract Administration Services District, Cincinnati, administers contracts for boiler inspections.

Each major command will prepare a schedule of boilers to be inspected at each CONUS installation and forward it (in duplicate) on AF Form 288, Request for Boiler Inspection, to the Defense Supply Agency, Defense Contract Administration Services District, Cincinnati, Federal Office Building, 550 Main Street, Cincinnati, Ohio 45202. The schedule must be submitted before 1 April of each year preceding the fiscal year to which the schedule applies. The schedule must contain the following information:

The name and location of the base, plant, or project; the name and number of the buildings in which the boilers are installed; an identification of each boiler, as follows: the trade name; year built; year installed; type (water tube or fire tube); approximate size, expressed in total heating surface, boiler horsepower, Btu/hr or (for fire tube boilers) diameter; the date the inspection is desired (if not left to the discretion of the inspector); the type of inspection desired; and the name and title of the person to whom the inspector is to report. In oversea areas and foreign countries, the National Board of Boiler and Pressure Vessel Inspectors establishes basic qualifications for firms and individuals that perform boiler inspections within the continental United States. These qualifications are used as guidance in other areas.

A recognized authority should certify the qualifications of firms and individuals who conduct inspections in oversea installations or foreign countries. If such an authority is not available, the responsible major commander of the Air Force Regional Civil Engineer is authorized to certify to the competence of firms and individuals.

Inspections will conform to the applicable code established by a recognized competent authority or, if no adequate standards exist, to the American Society of Mechanical Engineers (ASME) code.

Preparing and forwarding inspection reports. Immediately upon completion of the inspection, prepare AF Form 296, Boiler Inspection Acknowledgment, in duplicate. The base civil engineer will sign and immediately forward the original to the Defense Supply Agency, Defense Contract Administration Services District, Cincinnati. He will retain the copy in his files.

Within 30 days of the date of inspection, the contractor will forward five copies of a typewritten report on AF Form 1222, Boiler Inspection Report, to the Defense Supply Agency, Defense Contract Administration Services District, Cincinnati. This report describes the physical condition of each boiler inspected and lists repairs or alterations required, or explains, if applicable, why a required hydrostatic pressure test was not performed at a pressure of 1½ times the safety valve setting.

The Administrative Contracting Officer at the Defense Supply Agency, Defense Contract Administration Services District, Cincinnati, will approve invoices for payment upon receipt of AF Form 296 and forward five copies of AF Form 1222 to the major commands concerned.

The major command will transmit three copies of the AF Form 1222 to the base. The base civil engineer will frame one copy between two layers of glass and post it in the boiler room.

Exercises (671):

1. State the test requirements associated with high temperature water.
2. How are boilers, generators, and tanks scheduled for a hydrostatic inspection?
3. Describe the procedures for reporting the results of a hydrostatic test.

External Water Temperature

FOR MANY YEARS, man has been boiling water for various reasons. One important reason was for the purpose of heating his home—later his place of business. It was only a comparatively few years ago, however, when he discovered that just any kind of water should not be used in boilers. Up to this time, the boiler operator accepted a dirty boiler as a necessary evil. The only treatment used to combat the dirty boiler condition was an annual cleaning. In recent years, great strides have been made in the chemical treatment of feedwater to protect the boiler. Today, the different feedwater tests and treatments have been made so simple that the operator no longer has to be a chemist. The major requirements of a good boiler operator are an interest in his job and the proper background to give him a good understanding of his job. With these qualifications and the proper equipment, almost any airman can become a "boilerroom chemist."

In this chapter, you have the opportunity to study information you will need when you are assigned responsibilities pertaining to water treatment. We discuss the sources and characteristics of water, the objectives of water treatment, the types of equipment used to soften water, and the types of equipment used to deaerate water.

4-1. Water Sources and Characteristics

The hydrologic cycle is a term used to describe the natural circulation of water in, on, and above the earth. It plays an important role in the classification of sources for water. The characteristics of water dictate the type of treatment necessary prior to using it in the boiler.

672. Specify the processes involved in the hydrologic cycle and identify the classification of water sources.

The hydrologic cycle or natural circulation of water is shown in figure 4-1. This is a

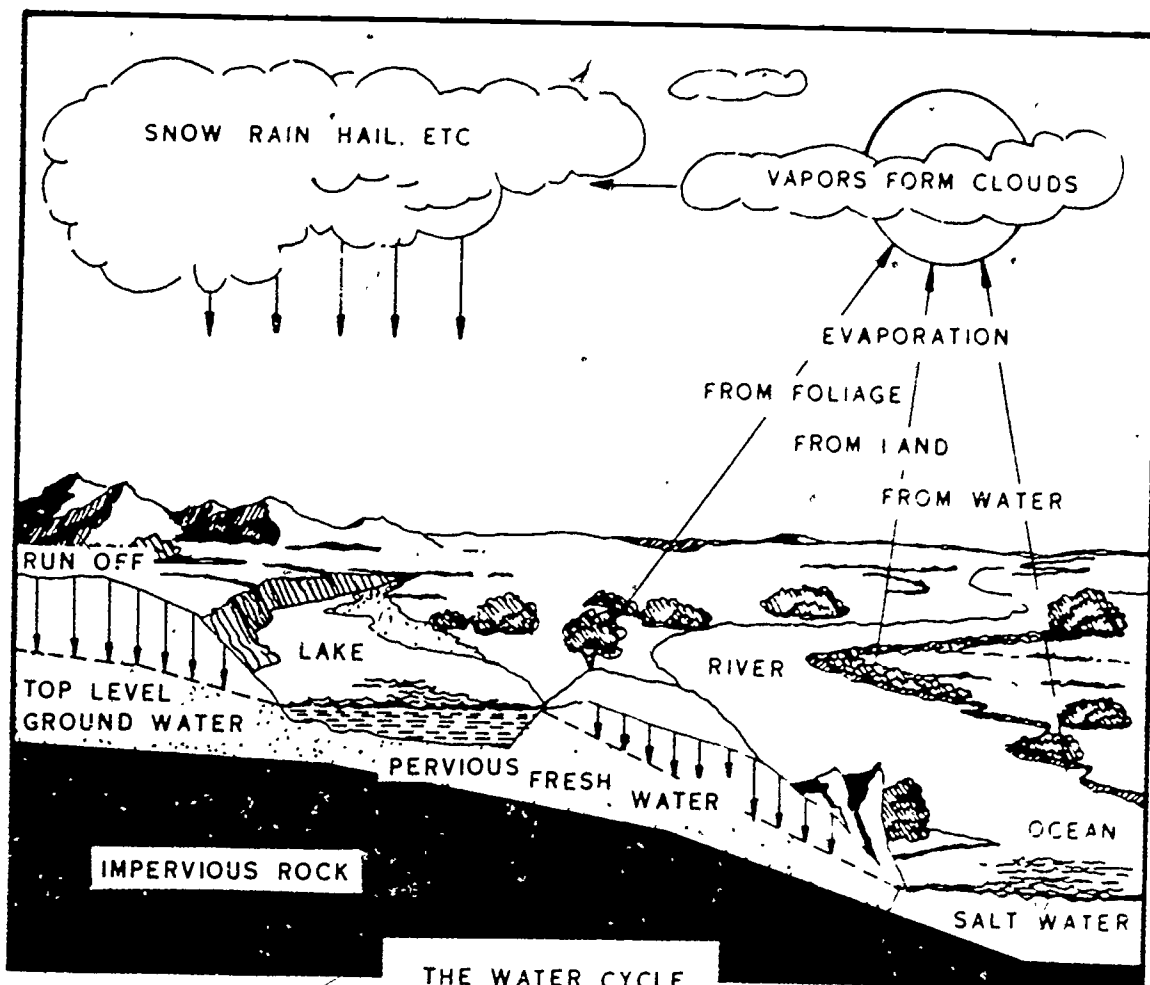
simplified illustration showing the more important features of the cycle. The processes in the hydrologic cycle include evaporation, precipitation, infiltration, and runoff. Each of these features could have an effect on the sources of water. There are two general sources of water: surface water, such as brooks, streams, rivers, ponds, reservoirs, and creeks; and ground water which is water that has seeped into the ground, to appear later as springs or as water to be tapped by wells or shafts. Ground water is usually subdivided into spring water, shallow well water, deep well water, and mine water.

Exercises (672):

1. What processes are involved in the hydrologic cycle?
2. Identify the two general classifications of water sources.
3. Identify the subdivisions in the classification of ground water.

673. List the common impurities in water and describe the characteristics of these impurities.

Suspended Impurities and Their Characteristics. As you found out earlier, water in its natural state is never pure. Rainwater, the closest to pure water, contains enough oxygen and carbon dioxide to make it corrosive. Ground water has dissolved impurities, and surface water is normally high in suspended impurities. Some of the common suspended impurities are turbidity, organisms, and algae.



THE WATER CYCLE

CN-084

Figure 4-1. Hydrologic cycle.

Turbidity. Turbidity is the term applied to suspended matter, of any nature, in a water supply. A distinction is sometimes made between suspended matter that settles rapidly and that which settles slowly, the former being called "sediment" and the latter "turbidity." Turbidity, present as a dirty sediment, is objectionable for practically all uses and this has led to certain standards of tolerances. In the United States, the Public Health Service drinking water standards for drinking and culinary water supplied by common carriers in Interstate Commerce requires that turbidity not exceed 10 parts per million (ppm) silica scale. Turbidity is expressed in an analysis as silica and it imparts an unsightly appearance to water. Turbidity also leaves deposits of sediment in waterlines, cooling systems, and boilers, and thereby interferes with industrial processes.

Organism. Although some organisms found in water can cause disease when consumed,

they do not really affect our operation, as we are mainly concerned with the effects of impurities on mechanical equipment. Normally, organisms in a boiler water supply are not significant.

Algae. A concentration of algae in the water causes taste, odor, color, and turbidity. Other than extreme cases, we are concerned only with the latter two. Turbidity will have to be removed by filtration or sedimentation, with-or without the aid of chemicals.

Dissolved Impurities and Their Characteristics. The amount of dissolved minerals in water depends on the length of time the water was in contact with the minerals. When ground water is in contact with minerals for a long period of time, it often contains many dissolved impurities. We describe these impurities and their effects in the following paragraphs.

Hardness (minerals or salts). Minerals or salts present in the feedwater in dilute form

COMMON IMPURITIES FOUND IN WATER

CONSTITUENT	CHEMICAL FORMULA	DIFFICULTIES CAUSED	MEANS OF TREATMENT
TURBIDITY	NONE EXPRESSED IN ANALYSIS AS SiO_2	IMPARTS UNSIGHTLY APPEARANCE TO WATER DEPOSITS IN WATER LINES PROCESS EQUIPMENT BOILERS ETC INTERFERES WITH MOST PROCESS USES	COAGULATION SETTLING AND FILTRATION
COLOR	NONE EXPRESSED IN ANALYSIS AS UNITS OF COLOR ON ARBITRARY SCALE	MAY CAUSE FOAMING IN BOILERS HINDERS PRECIPITATION METHODS SUCH AS IRON REMOVAL HOT PHOSPHATE SOFTENING CAN STAIN PRODUCT INURE	COAGULATION AND FILTRATION CHLORINATION ABSORPTION BY ACTIVATED CARBON
HARDNESS	CALCIUM AND MAGNESIUM SALTS EXPRESSED AS $CaCO_3$	CHIEF SOURCE OF SCALE IN HEAT EXCHANGE EQUIPMENT BOILERS PIPE LINES ETC FORMS CURDS WITH SOAP INTERFERES WITH DYEING ETC	SOFTENING DISTILLATION INTERNAL BOILER WATER TREATMENT SURFACE ACTIVE AGENTS
ALKALINITY	BICARBONATE (HCO_3) CARBONATE (CO_3) AND HYDRATE (OH) EXPRESSED AS $CaCO_3$	FOAMING AND CARRYOVER OF SOLIDS WITH STEAM EMBRITTLEMENT OF BOILER STEEL BICARBONATE AND CARBONATE PRODUCES CO_2 IN STEAM A CAUSE OF CORROSION	LIME AND LIME SODA SOFTENING ACID TREATMENT HYDROGEN ZEOLITE SOFTENING DEALKALIZATION ANION EXCHANGE DISTILLATION
FREE MINERAL ACID	H_2SO_4 HCL ETC EXPRESSED AS $CaCO_3$	CORROSION	NEUTRALIZATION WITH ALKALIES
CARBON DIOXIDE	CO_2	CORROSION IN WATER LINES AND PARTICULARLY STEAM AND CONDENSATE LINES	AERATION DEAERATION NEUTRALIZATION WITH ALKALIES FILMING AND NEUTRALIZING AMINES
pH	HYDROGEN ION CONCENTRATION DEFINED AS THE LOGARITHM OF THE RECIPROCAL OF THE HYDROGEN ION CONCENTRATION	pH VARIES ACCORDING TO ACIDIC OR ALKALINE SOLIDS IN WATER MOST NATURAL WATERS HAVE A pH OF 6.0 OR 8.0	pH CAN BE INCREASED BY ALKALINES AND DECREASED BY ACIDS.
SULFATE	SO_4	ADDS TO SOLIDS OF WATER BUT IN ITSELF IS NOT USUALLY SIGNIFICANT COMBINES WITH CALCIUM TO FORM CALCIUM SULFATE SCALE	DEMINERALIZATION DISTILLATION
CHLORIDE	Cl-	ADDS TO SOLIDS CONTENT AND INCREASE COMPOSIVE CHARACTER OF WATER	DEMINERALIZATION DISTILLATION

CNC 077A

Figure 4-2. Common impurities in water (part 1).

become concentrated in the boiler water. These slightly soluble minerals can therefore deposit or precipitate out of the boiler water. They may come out in the form of a scale on the boiler surface or in the form of a sludge distributed throughout the body of the boiler water.

Alkalinity. This is a condition caused by the presence of bicarbonates (HCO_3), carbonates (CO_3), and hydroxides (OH). The effect of these compounds is foaming and carryover of solids with the steam. They also may cause embrittlement of boiler steel. An undesirable feature of bicarbonate and carbonate in water is that, when heated, they release corrosive carbon dioxide (CO_2).

Free mineral acid. These are acids, such as sulfuric, hydrochloric, and carbonic, that occur naturally in water. The undesirable aspect of natural acid in water is the high corrosiveness to metal that exists.

Carbon dioxide. This gas, in combination with condensate, can form carbonic acid which causes corrosion in waterlines, particularly steam and condensate lines.

Sulfate (SO_4) Sulfate may add to the solids content of the water but, by itself, is not

usually significant. Sulfate combines with calcium to form calcium sulfate scale, which could have a detrimental effect on boiler efficiency.

Oil. Oil causes scale, sludge, and foaming in boilers. It also impedes heat exchange and is generally undesirable in most processes.

Iron. As iron precipitates, it can cause a discoloration of water. It is also a source of harmful deposits that may build up in waterlines and boilers.

Manganese. Same as iron.

Oxygen (O_2). When the oxygen that is dissolved in water is liberated, it can cause corrosion of waterlines, heat exchange equipment, boilers, return lines, etc.

Hydrogen sulfide (H_2S). This compound is responsible for the rotten egg odor prevalent in some waters, and it can also cause metal to corrode.

Ammonia (NH_3). This compound is highly corrosive to copper and zinc alloys and forms complex soluble ions.

Figures 4-2, 4-3, and 4-4 summarize the various impurities and their characteristics by laying the compounds out as constituents,

CONSTITUENT	CHEMICAL FORMULA	DIFFICULTIES CAUSED	MEANS OF TREATMENT
NITRATE	NO_3^-	ADDS TO SOLIDS CONTENT BUT IS NOT USUALLY SIGNIFICANT INDUSTRIALLY. HIGH CONCENTRATIONS CAUSE METH-EMGLOBINEMIA IN INFANTS. USEFUL FOR CONTROL OF BOILER METAL ENRICHMENT.	DEMNERALIZATION, DISTILLATION
FLUORIDE	F^-	CAUSE OF MOTTLED ENAMEL IN TEETH. ALSO USED FOR CONTROL OF DENTAL DECAY. NOT USUALLY SIGNIFICANT INDUSTRIALLY.	ABSORPTION WITH MAGNESIUM HYDROXIDE, CALCIUM PHOSPHATE, OR BONE BLACK.
SILICA	SiO_2	SCALE IN BOILERS AND COOLING WATER SYSTEMS. INSOLUBLE TURBINE BLADE DEPOSITS DUE TO SILICA VAPORIZATION.	HOT PROCESS REMOVAL WITH MAGNESIUM SALTS. ABSORPTION BY HIGHLY BASIC ANION EXCHANGE RESINS. IN CONJUNCTION WITH DEMNERALIZATION DISTILLATION.
IRON	Fe (FERRIC) Fe (FERROUS)	DISCOLORS WATER ON PRECIPITATION. SOURCE OF DEPOSITS IN WATER LINES, BOILERS, ETC. INTERFERES WITH DYEING, TANNING, PAPER MFG, ETC.	AERATION, COAGULATION AND FILTRATION, LIME SOFTENING, CATION EXCHANGE, CONTACT FILTRATION, SURFACE ACTIVE AGENTS FOR IRON RETENTION.
MANGANESE	Mn	SAME AS IRON	SAME AS IRON
OIL	EXPRESSED AS OIL OR OTHER EXTRACTIBLE MATTER	SCALE SLUDGE AND FOAMING IN BOILERS. IMPEDES HEAT EXCHANGE. UNDESIRABLE IN MOST PROCESSES.	BAFFLE SEPARATORS, STRAINERS, COAGULATION AND FILTRATION, DIATOMACEOUS EARTH FILTRATION.
OXYGEN	O_2	CORROSION OF WATER LINES, HEAT EXCHANGE EQUIPMENT, BOILERS, RETURN LINES, ETC.	DEAERATION, SODIUM SULFITE, CORROSION INHIBITORS.
HYDROGEN SULFIDE	H_2S	CAUSE OF "ROTTEN EGG" ODOR, CORROSION.	AERATION, CHLORINATION, HIGHLY BASIC ANION EXCHANGE.
AMMONIA	NH_3	CORROSION OF COPPER AND ZINC ALLOYS BY FORMATION OF COMPLEX SOLUBLE ION.	CATION EXCHANGE WITH HYDROGEN ZEOLITE, CHLORINATION, DEAERATION.

CNC 0778

Figure 4-3. Common impurities in water (part 2).

chemical formula, the difficulties encountered when the compound is present and the appropriate means of treatment. An explanation of the various means of treatment will be covered in much more detail later in this chapter and in Chapter 5.

Exercises (673):

1. What are the two distinct groups of impurities found in water?

CONSTITUENT	CHEMICAL FORMULA	DIFFICULTIES CAUSED	MEANS OF TREATMENT
CONDUCTIVITY	EXPRESSED AS MICROMHOS SPECIFIC CONDUCTANCE	CONDUCTIVITY IS THE RESULT OF IONIZABLE SOLIDS IN SOLUTION. HIGH CONDUCTIVITY CAN INCREASE THE CORRO-SIVE CHARACTERISTICS OF WATER.	ANY PROCESS WHICH DECREASES DISSOLVED SOLIDS CONTENT WILL DECREASE CONDUCTIVITY. EXAMPLES ARE DEMNERALIZATION, LIME SOFTENING.
DISSOLVED SOLIDS	NONE	"DISSOLVED SOLIDS" IS MEASURE OF TOTAL AMOUNT OF DISSOLVED MATTER DETERMINED BY EVAPORATION. HIGH CONCENTRATION OF DISSOLVED SOLIDS ARE OBJECTIONAL BECAUSE PROCESS INTERFERENCE IS A CAUSE OF FOAMING IN BOILERS.	VARIOUS SOFTENING PROCESSES SUCH AS LIME SOFTENING AND CATION EXCHANGE BY HYDROGEN ZEOLITE WILL REDUCE DISSOLVED SOLIDS. DEMNERALIZATION DISTILLATION.
SUSPENDED SOLIDS	NONE	"SUSPENDED SOLIDS" IS THE MEASURE OF UNDISSOLVED MATTER DETERMINED GRAVIMETRICALLY. SUSPENDED SOLIDS PLUG LINES, CAUSE DEPOSITS IN HEAT EXCHANGE EQUIPMENT, BOILERS, ETC.	SUBSIDENCE FILTRATION, USUALLY PRECEDED BY COAGULATION AND SETTLING.
TOTAL SOLIDS	NONE	"TOTAL SOLIDS" IS THE SUM OF DISSOLVED AND SUSPENDED SOLIDS DETERMINED GRAVIMETRICALLY.	SEE "DISSOLVED SOLIDS" AND "SUSPENDED SOLIDS".

CNC-077C

Figure 4-4. Common impurities in water (part 3):



2. List the common suspended impurities found in water.
3. Describe the characteristics of turbidity.
4. What are the characteristics of concentrated algae?
5. List the common dissolved impurities found in water.

6. The following statements describe impurities found in water. Fill in the adjacent blank spaces with the name of the impurity that best fits the description.
- Imparts unsightly appearance. Leaves deposits in waterlines, process equipment, boilers, etc. _____
 - Causes corrosion in waterlines, particularly in steam and condensate lines. _____
 - Causes scale, sludge, and foaming in boilers. Impedes heat exchange and is generally undesirable in most processes. _____
 - Causes corrosion of copper and zinc alloys by formation of complex soluble ions. _____

4-2. Objectives of Treatment

Although the water received at the heating plant has been treated to make it safe, clear, and palatable, it often contains impurities that make it unsatisfactory for boiler use. Therefore, additional treatment is necessary to overcome specific characteristics that are undesirable. The water may be treated before it enters a boiler or after it is in the boiler system.

674. Specify the primary purpose of boiler water treatment.

Purpose of Treating Boiler Water. One of the first objectives of water treatment is to prevent boiler-scale formations and pitting. In addition, a successful treatment accomplishes the following: permits ready removal, by blowdown, of most of the sludge formed in the boiler water; provides corrosion control; prevents boiler water from embrittling boiler metal; eliminates the possibility of priming or foaming of boiler water; keeps concentration

of dissolved solids in boiler water below the point that requires excessive blowdown. The treatment must also provide protection for preboiler equipment and steam and condensate lines; prevent corrosion or deposition of solids in feedwater heaters and boiler feedlines; keep steam dry and low in solids in feedwater heaters and boiler feedlines; and keep steam dry and low in solids to protect equipment through which steam and condensate flow. Treatment of boiler water with a chemical that also treats steam and condensate may be necessary to control corrosion in return lines.

Exercises (674):

- Specify the primary purpose of treating boiler water.
- How can corrosion of return lines be controlled?

675. Specify the main effects of boiler water treatment.

Mechanical Water Treatment. Many water treatment objectives are achieved best by mechanical means. Examples of mechanical means are: feedwater heaters, blowdown, steam washer, and evaporators. Adequate mechanical maintenance throughout the plant will also achieve many water treatment aims and eliminate or lessen the need for chemical treatment. For example, maintaining a high rate of return to the boiler decreases the quantity of chemicals needed to treat boiler water. Proper operation of feedwater heaters and the venting of gases may control corrosion in the feedlines and in the boiler, thereby eliminating the need for chemical corrosion control. Therefore, the first step in eliminating many water condition difficulties is good mechanical housekeeping throughout the plant. Nevertheless, it is frequently necessary to combine controlled chemical treatment with mechanical treatment and maintenance to accomplish all water treatment objectives.

Chemical Water Treatment. Chemical treatment may be external, internal, or a combination. The principal difference is that in external treatment, raw water is changed or adjusted by chemical treatment outside the boiler to produce a different type of

feedwater, while in internal treatment, chemicals are fed into the water inside the boiler, usually through feedlines. External treatment, followed by some internal treatment, usually results in better boiler water quality than internal treatment alone. However, external treatment requires considerable equipment, such as chemical tanks, softeners, and filters. Also, installation costs are high. Therefore, it is used only when the available makeup water is hard or high in alkalinity or dissolved minerals, or when internal treatment alone will not maintain the desired boiler water conditions.

Determination of the precise point at which the hardness, alkalinity, or dissolved mineral concentration of a water necessitates external treatment depends on mechanical considerations, such as boiler type and design; the pressure and rating at which the boilers operate; the percentage of makeup water; the amount of sludge the boiler will tolerate; general considerations such as available space, operator adaptability; and economic considerations. In most Air Force plants, the boilers are small and operate at moderate pressures; available makeup water is not too high in hardness, alkalinity, or dissolved solids; and makeup requirements are small. In these plants, internal treatment alone gives satisfactory boiler water conditions; therefore, installation of external treatment equipment is not necessary.

Exercises (675):

1. List some of the equipment used for mechanical water treatment.
2. Specify the effects of the external chemical water treatment method.
3. What does the internal chemical water treatment method entail?

676. Identify the two classifications of external boiler water treatment and list an example of each classification.

External Water Treatment. External treatment is divided into two general classifications: the ion-exchange methods, which convert scale-forming compounds of

calcium and magnesium to nonscale-forming compounds of sodium and hydrogen; and the precipitation method, which separates the scale-forming materials from the boiler feedwater before it enters the boilers. An example of the former is the zeolite treatment system; of the latter, the lime-soda process.

Exercises (676):

1. Identify the two classifications of external water treatment.
2. List an example for each method of external boiler water treatment.

4-3. Water Softeners

Softening is an action in which hardness, caused by calcium and magnesium, is removed from water. These elements are responsible for most scale and sludge in boilers. Except for special cases, scale prevention is an operation which does something about the calcium and magnesium in water.

677. Name the types of water softeners and cite the operating principles for each type.

Water conditioners are often used to soften and otherwise condition the feedwater before it is fed into the boiler. This work is accomplished by removing the minerals that cause hardness. Air Force installations normally use three processes for water softening. They are sodium-zeolite, lime-soda, and hydrogen-zeolite.

Sodium-Zeolite. The Air Force uses the pressure-type sodium-zeolite softener. The unit consists of a steel shell that contains a bed of zeolite supported by several layers of graded gravel. These softeners may be operated either manually or automatically. A manually operated water softener is shown in figure 4-5.

The water is admitted to the upper portion of the shell and passes over the zeolite bed. There the ions of calcium and magnesium, which cause the hardness in water, are attached to the zeolite and replace the ions of soluble sodium salt. This action is called ion exchange. Then, the water that has passed through the bed of zeolite passes on through the gravel bed and collects in an underdrain system. The accumulated soft (less corrosive)

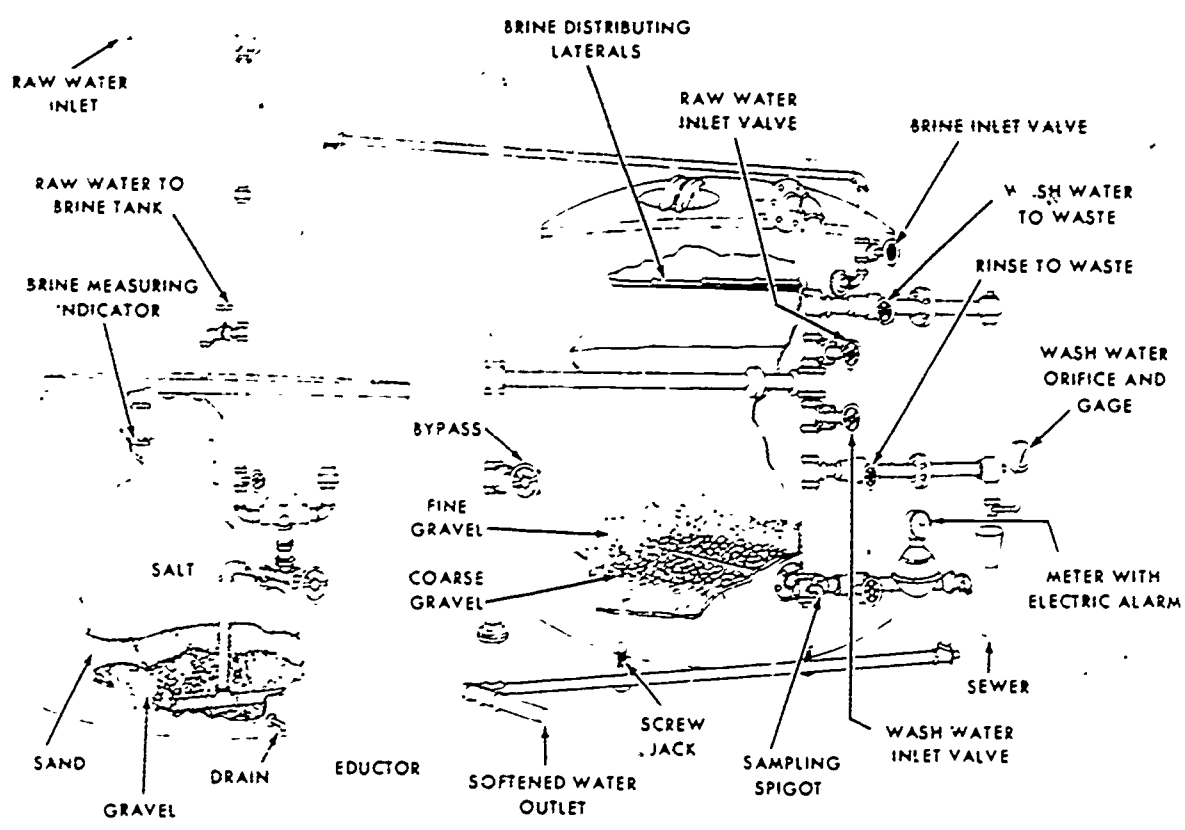


Figure 4-5. Sodium-zeolite softener.

water is discharged to the feedwater system and goes to the boiler, as required.

A water softener does not have an unlimited capacity for removal of hardness. The unit eventually reaches a point where ion exchange no longer occurs and the softening process stops. The capacity of most water softeners is stamped on a plate mounted on the unit.

When a water softener reaches its capacity, as determined by a hardness test, it must be regenerated. The first step of regeneration is the backwash of the zeolite bed. During this step, the flow of water through the softener is from bottom to top; this flow washes the gravel and zeolite beds and removes the accumulated sediment. The manufacturer recommends the rate of flow for each part of the cycle. Next is the process called brining. The brining process is done to regenerate the zeolite. A predetermined volume of saturated brine is admitted into the softener, and the soluble sodium salt ions replace the ions of calcium and magnesium. The directions for mixing the brine are usually furnished by the softener manufacturer. The brine is usually a mixture of rock salt and water.

When the brining process is finished, the

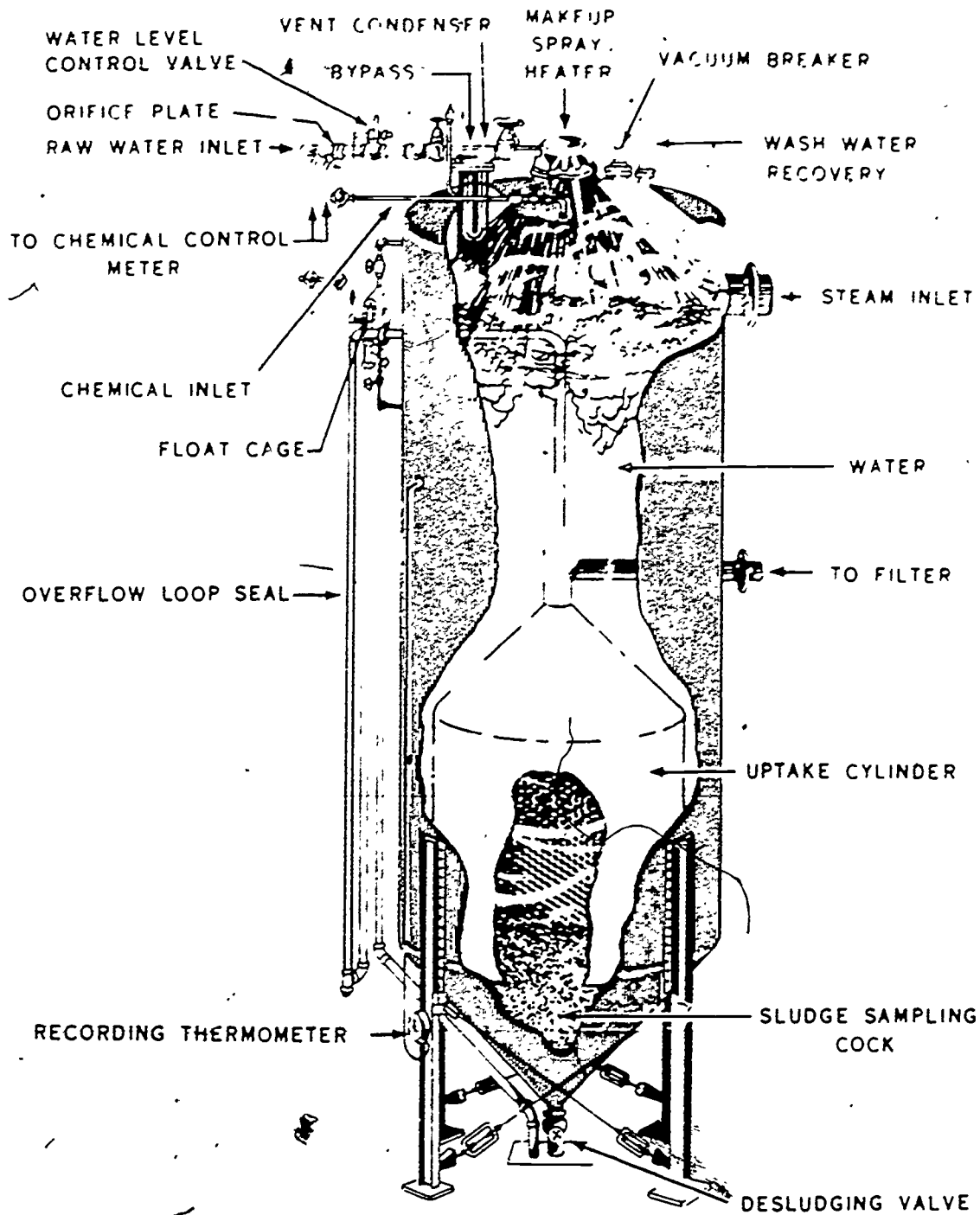
softener must be rinsed with a predetermined amount of clean water. During the rinsing, the water is allowed to flow over the zeolite from top to bottom. This washes the chlorides of calcium, magnesium, and excess salt into the drain. After this, the softening cycle may start all over again.

When you know the capacity of a water softener, you can check its performance efficiency. For example, if a sodium-zeolite unit has an exchange capacity of 250 kilograins, 1 kilograin (kgr) is equal to 1000 grains and the raw, unsoftened water has 10 grains of hardness per gallon, the unit can soften 25,000 gallons (250 kgr = 250,000 grains divided by 10 grains = 25,000 gals) of water between regenerations. Should the unit show the need for regeneration after processing only 20,000 gallons of the same 10-grain hardness of water, then the

efficiency of the unit is 80 percent, or $\frac{20,000}{25,000}$

$$\frac{\text{gal}}{\text{gal}} \times 100 \text{ percent} = 80 \text{ percent. Check the}$$

efficiency of the water softener regularly. If it shows a marked decrease in efficiency, you



CGK-006

Figure 4-6. Lime-soda softener.

should determine whether the hardness of the raw water has changed or if the change is due to other factors.

Lime-Soda. The lime-soda softener is used to precipitate the hardness salts of calcium and magnesium from the water. A typical

lime-soda water softener is shown in figure 4-6. When using this hot process lime-soda water softener, you should strictly follow the manufacturer's instructions.

The hard water is heated to 212° F. or higher by using live steam or exhaust steam in

a jet, tray, or deaerating heater. The high operating temperature develops maximum treatment efficiency. A mixture of lime and soda ash is added to the hot water, causing the hardness salts to precipitate. The softening process takes from 1 to 2 hours. The filter removes the remaining precipitate and leaves the water clear. The heater element must be thoroughly vented at all times so that the dissolved gases will be removed. The softener should be regenerated in accordance with the manufacturer's instructions.

Lime-soda softening equipment requires special maintenance to insure the efficient operation of heaters, filters, and chemical feed pumps. All equipment including pumps, meters, valves, motors, and the like must be inspected periodically and adjusted according to the manufacturer's instructions in order to get proper service from the unit.

Hydrogen-Zeolite. The hydrogen-zeolite acid cycle softener is used when it is necessary to reduce alkalinity and soften the water at the same time. Consequently, these softeners are not widely used in the Air-Force. This type of water softener is used only where special water problems are involved. The softeners themselves can present quite a problem when they are not properly operated. When you are adding acid to the water, you can very easily develop acid corrosion in the system. The proper operation and maintenance procedures are normally furnished with the softener by its manufacturer. Hydrogen-zeolite softeners vary considerably with each unit; therefore, we do not attempt to discuss the differences in each of these units. The operating principle is basically the same as the sodium-zeolite water softener.

Exercises (677):

1. What are the three types of water softening process equipment normally used on Air Force installations?
2. Cite the operating principle of the sodium-zeolite water softener.
3. Why are water softeners used in feedwater systems?

4. After the brining process, what is the next step in regenerating a sodium-zeolite water softener?
5. Cite the operating principle for the lime-soda softener.
6. Under what conditions is the hydrogen-zeolite softener normally used?

678. Specify major servicing objectives for water softening units.

Inspection and Maintenance of Softening Units. The inspection and servicing of all softening units is essential to keep water softener operations at peak efficiency. Regarding softener operation, you should consult the manufacturer of the softener from time to time. In many cases, performance of the softener is guaranteed by the manufacturer. These agreements guarantee free service and repair of the softener for a specified length of time only when the unit is operated according to the manufacturer's instructions. When major repairs of water softening units are required, contact the manufacturer immediately to obtain the proper materials and service instructions. The next several paragraphs outline the primary inspection, servicing, and maintenance requirements for the water softening equipment just discussed.

Daily inspections and maintenance. Maintain a proper log book on the density of the brine, the hardness of the water leaving the softener, and the quantity of water softened between regenerations. Fill the salt tanks with clean salt and enter the amount added in the log book. Properly backwash the unit before adding the brine and record the amount of brine solution added for each regeneration. Examine the sump for zeolite carryover after each regeneration and make sure the equipment stays clean and dry.

Monthly inspections and maintenance. If operating tests indicate difficulty, perform the inspection and service as described under semiannual inspections and maintenance.

Semiannual inspections and maintenance. Check the exterior of the steel tanks for cleanliness and condition of paint. Paint at

least once a year. Wire-brush, clean, and dry all surfaces thoroughly before painting. Repaint with red lead all spots that show rust or removal of primer. Apply good quality moisture-resistant paint to the entire surface. Check seams for leakage. Failure at seams is due to poor welding or water hammer in the supply and outlet lines. Reweld faulty seams before painting. Check and level tanks with the adjustable jacks.

Tighten all hoops on wood tanks equally. If leaks persist after tightening, contact the manufacturer's representative. Wire-brush, clean, and paint all hoops, nuts, lugs, and other metal parts at least once a year. Do not paint wood surfaces except when used for brine. Check piping and fittings for leaks; make necessary repairs. Wire-brush, clean, and paint at least once a year. Check valves for leakage and stoppage. Pack and lubricate. Repair or replace defective parts. Check control valves for numbering and labeling. If not properly identified, correct according to manufacturer's instructions.

See that backwash and rinse flow control operate freely and deliver the flow rate recommended by the manufacturer. Make necessary adjustments and lubricate. Check sump for presence of zeolite. When water pressure varies widely, adjust backwash and rinse flow control for correct pressure to avoid waste of zeolite or an upset of gravel bed by high flow rates. Where a weir is used, check holes for obstructions. Average backwash rate is 6 to 8 gpm per square foot of zeolite surface. Insufficient backwash rate leaves a dirty, packed zeolite bed with low capacity.

Check watermeter face glass for cracks and for rusty, loose, or sticking indicator hands and integrator dials. Check meter accuracy with a master meter or calibrated container. Check pressure gage calibration with a standard gage; make necessary adjustments. Check differential pressure between inlet and outlet of softener. If differential pressure is excessive, look for dirty or packed zeolite bed, excessive fines, obstructions in piping, or a defective drain system; check backwash flow controls, rinse flow controls, characteristics of raw water, zeolite bed depth, and condition of zeolite bed, in the order named.

Drain the brine saturator tank and remove salt and gravel. Thoroughly clean the tank as well as the outlet to the brine tank. Now clean and adjust the makeup water, float control mechanism. After you have finished this task, wire-brush, dry, repair all leaks, and paint both interior and exterior of steel or

wood tanks with bitumastic-base paint. However, if the tank is steel, it will need a coat of red lead first. Finally, you must wash, resize, and replace the gravel according to the manufacturer's instructions.

Drain and wash the brine measuring tank. Clean its surfaces with a wire brush. Paint with one coat of red lead followed by a coat of bitumastic-base paint. (Galvanized tanks may not require frequent painting.) Check flow rate of brine entering the tank and make necessary adjustments. Too rapid a flow rate results in weak brine solution. Check the brine ejector for normal operation. Repair or replace worn or defective parts. If operation is poor, look for clogging of ejector, low water pressure, or obstruction of brine distribution system. Locate and remove the cause of difficulty if you can.

Check for corrosion in the interior of the shell to a distance of 6 inches below the zeolite bed level. Wire-brush to remove accumulation of dirt and rust, taking care not to contaminate the bed. Stop serious corrosion and pitting in steel tanks by cleaning them thoroughly and applying a protective coating; sandblasting is preferred. If corrosion is serious, consult the tank manufacturer. Check the water and brine distribution system for obstructions, corrosion, and rigidity of support. Clean and wire-brush thoroughly. Paint if corrosion is severe.

Annual inspections and maintenance. Carefully remove the excessive fines by scraping off about 1/2 to 1 inch of the entire surface of the zeolite bed. Replace it with an equal amount of new zeolite and level the bed. If fines exceed 1 inch in thickness, determine and remove the cause. During the probing operation to determine zeolite bed depth, prepare a contour sheet showing the level of gravel bed. Serious disturbances require complete removal of all zeolite and gravel, correction of causes of upset, and replacement according to manufacturer's instructions.

Every 2 or 3 years, remove all zeolite and gravel, taking care not to mix zeolite and gravel more than necessary. Place removed material in suitable containers. When the tank is empty, inspect the underdrain system thoroughly. Check all orifices, nozzles, strainers, and laterals for obstruction and wear. Check plate distribution for proper level and alignment. Wash and clean the tank thoroughly; paint if necessary. Wash gravel free of all zeolite, then resize and replace it according to the manufacturer's instructions. Wash and replace zeolite to bring the bed up

to desired level. (For details on this operation, refer to manufacturer's instructions.)

Exercises (678):

1. Why is it so essential that water softening units be properly inspected and serviced?
2. Describe the servicing procedures necessary if there is an insufficient backwash rate in a zeolite softener.
3. What maintenance is required when the gravel bed of a zeolite unit is disturbed?

679. Specify the fundamental purpose and objectives of the zeolite inspection.

Zeolite Mineral and Salt Inspection. The zeolite must be inspected to determine its condition. The zeolite bed must be inspected for fines, depth, and mud accumulations. The bulk storage of the salt and zeolite must be inspected to insure that both are kept in tight, dry containers. Let's start the inspections with the bulk salt storage.

Bulk salt storage.

- a. Check for cleanliness and dryness of salt storage.
- b. Protect salt from moisture and excessive dust.
- c. See that the salt provided is of proper quality.
- d. Use only clean salt.

Reserve zeolite storage. See that mineral equivalent to 5 percent of the total zeolite in the softener is on hand and stored dry in tight bags or containers. Exposure to moisture causes loss of zeolite through broken containers or deterioration.

Condition of zeolite bed. See that mineral condition of the bed, take these steps:

- a. Drain the unit and open the manhole in the top.
- b. Check the zeolite bed for unevenness, excessive fines, surface accumulation of mud or dirt, mudballs, and mudholes. Locate mudholes, which are due to channeling or improper backwash, by probing with a stick.
- c. Remove all accumulations of mud.
- d. If serious mud accumulations, packing,

or channeling are present, check backwash operation and, if indicated, inspect the underdrain system.

e. Examine a zeolite sample taken 6 inches below the surface for coating of zeolite grains and disintegration of zeolite.

f. With manhole cover off, slowly start to backwash and note the nature of the bed as water comes through uniformly, permitting agitation of the entire bed.

g. Check for further evidence of channeling or packing and for gravel in the upper surface of the bed, indicating an upset gravel bed.

Zeolite bed depth. Determine the depth of the bed either by depth markings placed in the softener when installed or by a series of probings with a thin rod. If a rod is used, follow this procedure:

a. Insert it down through the zeolite bed until it strikes the gravel bed.

b. Note the distance.

c. Make 20 to 25 soundings over the surface of the bed and take the average depth.

d. Add sufficient zeolite to bring the level up to the required depth. Do not overfill, or the excess will be lost during the backwash operation and may plug lines and valves.

e. Permanently mark the level on the interior of the softener. Normal replacements do not exceed 3 percent per year.

Exercises (679):

1. Why is the zeolite bed inspected?
2. Name four major areas of inspection of salt and zeolite.

680. Cite major objectives of the lime-soda softener inspection and maintenance.

Lime-Soda Softeners. Lime-soda water softeners used in central boiler plants vary considerably in design; therefore, we do not attempt to include all inspections and maintenance for these systems. Where this type of softener is installed, use the manufacturer's manual to set up specific inspections and to establish maintenance schedules.

Daily inspections and maintenance. The following daily inspection and maintenance

tasks pertain to almost all hot-process lime-soda water softeners. Nevertheless, you should remember that these checks are used only as a guide. For specific inspections and maintenance, use the manufacturer's manual to set up the procedures for his equipment.

- a. Check alkalinity and hardness several times each day to determine the proper amount of chemicals to add.
- b. Check the chemical feed pump for operation and possible plugging of feedlines.
- c. Check the chemical proportioner for operation.
- d. Check the temperature of water in the reaction tank to determine whether the heater is functioning properly. Temperature should be 212° F. plus at sea level.
- e. Check the heater vent for proper amount of venting.
- f. Check the live steam makeup valve for operation and maintenance of uniform pressure.
- g. Blow down the reaction tank daily, or more often, depending on sludge accumulation.
- h. Check filters for pressure differential to determine if they need backwashing.
- i. Check the chemical solution tank and add chemicals, as required.
- j. Lubricate motors and pumps according to manufacturer's directions.

Monthly inspection and maintenance. The monthly inspections for water softeners should be thorough, because during inspections you can spot troubles that may cause major breakdowns. The following are general monthly inspections:

- a. Clean chemical solution tank and outlet strainer.
- b. Clean and flush the chemical feed pump.
- c. Lubricate and adjust the chemical proportioner.
- d. Check all lines and valves for leakage. Repair or replace, where necessary.

Semiannual inspections and maintenance. Semiannual inspections and maintenance are performed to keep the unit in top working condition and are given as follows:

- a. Open and clean the heater. Level and adjust the trays and spray nozzles. Clean and drain the vent condenser. Repack and reseal the live steam regulator valve and the water inlet control valve. Check the diaphragm in the regulator and replace it if worn. Adjust the regulator.
- b. Open and examine the filters in accordance with directions on zeolite softeners discussed previously. Conditions of

the filter bed are similar to those encountered in zeolite softeners except for the nature of medium used. Filters contain either sand or anthracite coal as a filter medium. Repair or replace damaged insulation on filters and lines.

Annual inspections and maintenance. The annual inspections, servicing, and maintenance may require the complete dismantling of the unit. This is the time for a thorough cleaning and replacement of worn or damaged parts.

- a. Drain, open, and clean the reaction tank. Repair or replace damaged insulation. If corrosion is excessive on interior of tank, scrape thoroughly and apply protective paint or other similar coating. If exterior is exposed, paint after thoroughly cleaning.
- b. Dismantle, clean, overhaul, and repack pumps.
- c. Repair all pipe and valve leaks, repack valves, and paint exposed surfaces.
- d. Call an electrician to service electrical controls and motors.

Exercises (680):

1. What service check must you make several times a day during operation of a hot-process lime-soda softener?
2. Cite the objectives of servicing procedures for lime-soda water softeners established on an annual basis.
3. What should you refer to when making specific inspections of lime-soda softeners?

681. State the cause of hardness in water and explain why it is undesirable.

Hardness of Water. Hardness is a property that water has from its dissolved mineral matter. The term has special meaning in the home and in laundries because hardness forms a scum with soap, which dirties wash water. These same impurities that waste soap also may coat boilers with scale. Soap is still sometimes used to test water for hardness. Hardness in water is undesirable because the effects can be costly and dangerous to boiler operation. Hardness is caused by calcium



and/or magnesium salts dissolved in water. It is usually easier to *dissolve* a substance in *hot* water; however, just the opposite is true in regards to hardness. The dissolved minerals that cause hardness "fall out" or precipitate from the boiler water as it is heated and the pressure increases. This precipitate which "falls out" often forms scale on boiler tubes and acts as an insulator. The heat transfer of the boiler drops and fuel consumption rises. The boiler efficiency is greatly reduced.

Exercises (681):

1. Hardness in water is caused by what?
2. Why is hardness in water undesirable?

682. List the methods of testing water for hardness and explain how a hardness test is performed.

Analyzing a water sample is the process of determining how much of various substances are present within the water. Complete analysis of water is a job for an experienced chemist, but operators should learn to make the routine tests that are necessary for the control of feedwater treatment. The tests performed in connection with softening processes are for water hardness. The two water hardness tests are the standard soap solution method and the EDTA (Disodium Ethylene Diamine Tetra Acetic Acid) solution method.

A standard soap solution is one of the items needed to perform a water hardness test by the first method. Standard soap solutions are placed on the market by chemists and various manufacturers, but many of these soap solutions are not really *standard*. To use a soap solution for testing, you must know the lather factor. This is the amount of soap solution required to raise a lather in soft or distilled water. In most cases, the lather factor for the soap solutions is clearly marked on the label. When the lather factor is not known, the following information can be used as a guide for determining it.

Determining lather factor Prepare about one-half pint of pure distilled water having less than .5 ppm (parts per million) of chloride. Pour 30 ml (milliliters) of distilled water into an 8 ounce bottle. Using a .5-ml

479

dropper, put one drop of the soap solution into the bottle containing the distilled water. Stopper the bottle and shake it vigorously. Lay the bottle on its side and observe the lather formed. If the lather persists and completely covers the surface of the water for 5 minutes, one drop will be your lather factor for this particular soap solution. If the lather does not persist for 5 minutes, continue adding drops of soap to the sample in the bottle until you find out the correct number of drops that proves to be the lather factor. Once this procedure is completed, you should record the number of drops that represents the lather factor. With a known lather factor, you are ready for the hardness test using the standard soap solution.

Soap solution hardness test. Draw a sample of water and pour 30 ml of the sample into an 8-ounce bottle. Using a .5-ml dropper, add drops of standard soap solution to the sample, one drop at a time. After each drop is added, stopper the bottle and shake it vigorously. Be sure to count the drops added as this will determine total hardness. Repeat this step until a lather can be formed that will last for 5 minutes while the bottle is laying on its side. After a lather has formed that lasts 5 minutes without breaking up, take the total drops used and deduct the drops that represent the lather factor. The remaining drops equal gpg (grains per gallon) hardness of the sample. To change grains per gallon to parts per million, you must multiply the gpg by the constant factor of 17.1.

Example: The amount of soap solution used was 11 drops and the lather factor is 1 drop. Deduct 1 from 11, leaving 10 drops which is equal to 10 gpg. Multiply 10 gpg by 17.1 which is 171 ppm.

EDTA solution hardness test. In this test, you are measuring the total hardness by volumetric titration with a versenate EDTA solution. This test is more accurate than the simple soap solution method discussed previously. The equipment required for this test includes a graduated measuring cylinder, a casserole, hardness buffer solution, hardness indicator powder, rubber-tipped stirring rod, and a graduated burette to hold and measure the versenate hardness reagent. To perform this test, you begin by measuring 50 ml of the water sample in a graduated cylinder and pouring it into a casserole. Next, add .5 ml of total hardness buffer solution and mix the solution by using the rubber-tipped end of the stirring rod. Add one measure of hardness indicator powder and mix with the stirring rod. The next step is to ready the burette with the versenate reagent. Fill the burette to

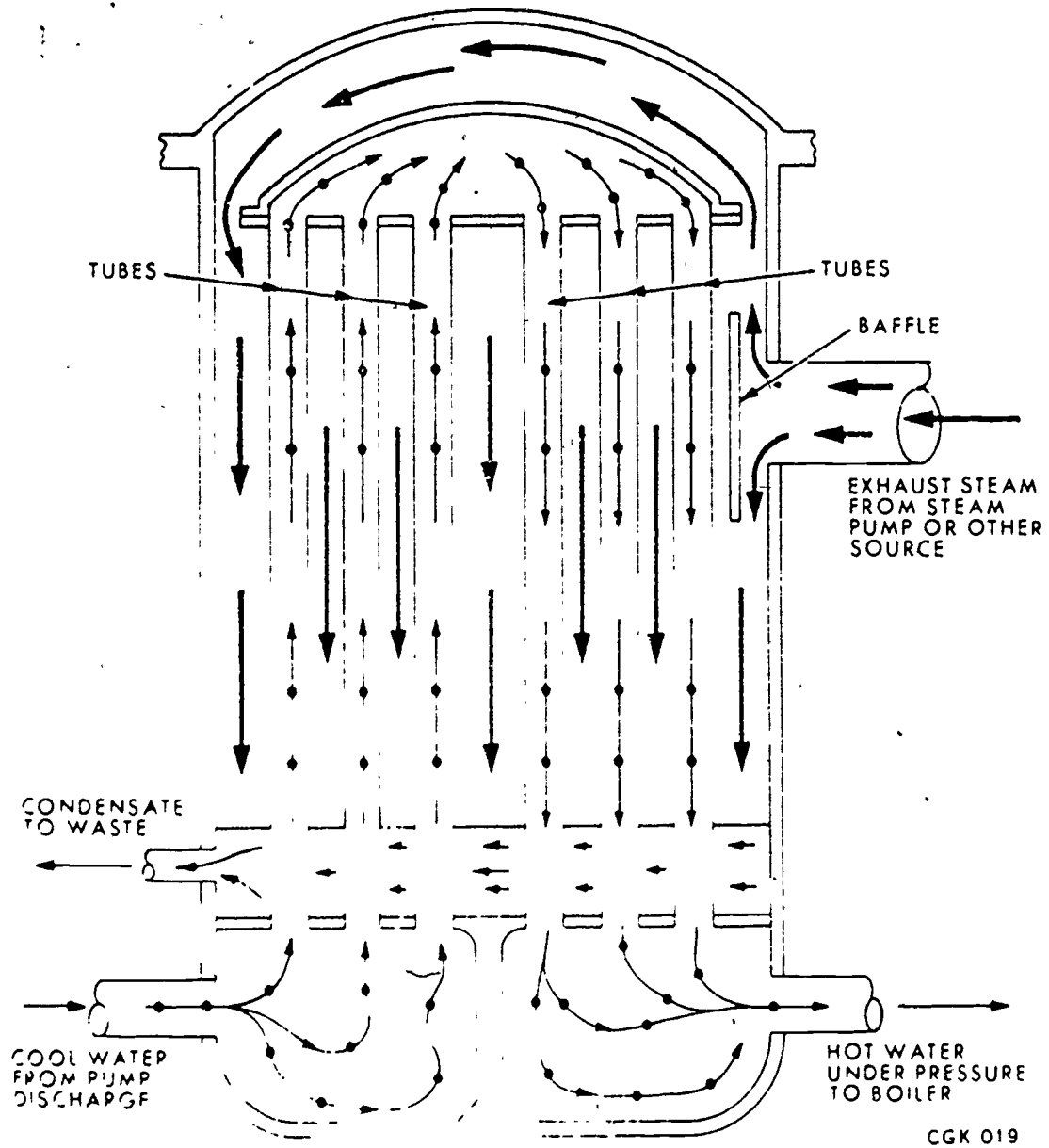


Figure 4-7. Closed-type feedwater heater.

CGK 019

the zero mark with the versenate hardness reagent. This is done by squeezing the aspirator attached to the automatic burette. The next step is to add the hardness reagent to the water sample in the casserole. You should add the reagent very slowly and mix it constantly until you reach the end point, which is when the water sample achieves a blue color. Specifically, it is the blue color that is present when the last trace of reddish color has just faded. When the end point is reached, determine the amount of reagent used by reading the graduations on the burette. The total number of milliliters of versenate reagent times the constant factor of

20 will give you the total hardness in parts per million. For example: 7 ml of reagent times the constant of 20 is equal to 140 parts per million hardness.

Exercises (682):

1. There are two methods of testing water for hardness. List them.
2. Explain how to perform a hardness test of water using a standard soap solution.

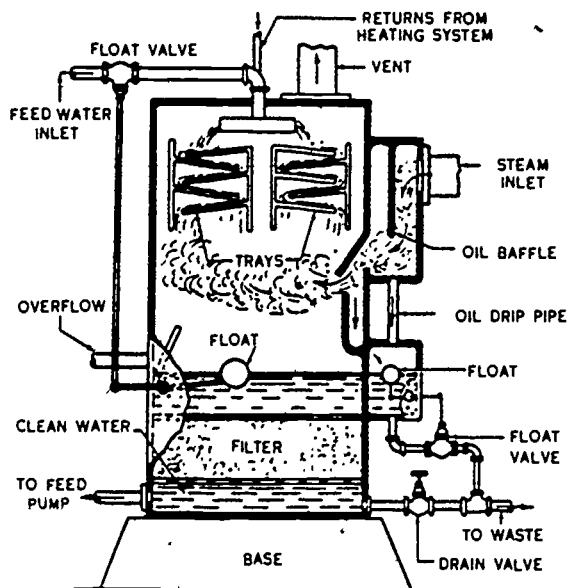


Figure 4-8. Open-type feedwater heater.

4-4. Deaerating Equipment

A highly corrosive gas dissolved in water is very undesirable when the water is in contact with metal, such as occurs with boiler operation. To prevent corrosion to metal surfaces in the boiler, the corrosive gases should be removed as much as possible. By using deaerating equipment, these gases can be removed before the water enters the boiler.

683. Cite the purpose of feedwater heaters and identify the types of equipment used in the deaerating process.

A feedwater heater is used to increase the efficiency of boiler operation by heating the feedwater. Preheating the feedwater reduces the amount of fuel required to bring the water to the boiling point and results in economy. Feedwater heaters raise the temperature of the makeup water by using exhaust steam or hot flue gases. Heating water liberates the oxygen and other gases carried in the water. The liberation of these gases decreases oxidation in the boiler and distribution system. There are several types and designs of feedwater heaters available and each unit differs according to the manufacturer. In general, however, feedwater heaters may be divided into three types: closed-type, economizers, and open-type.

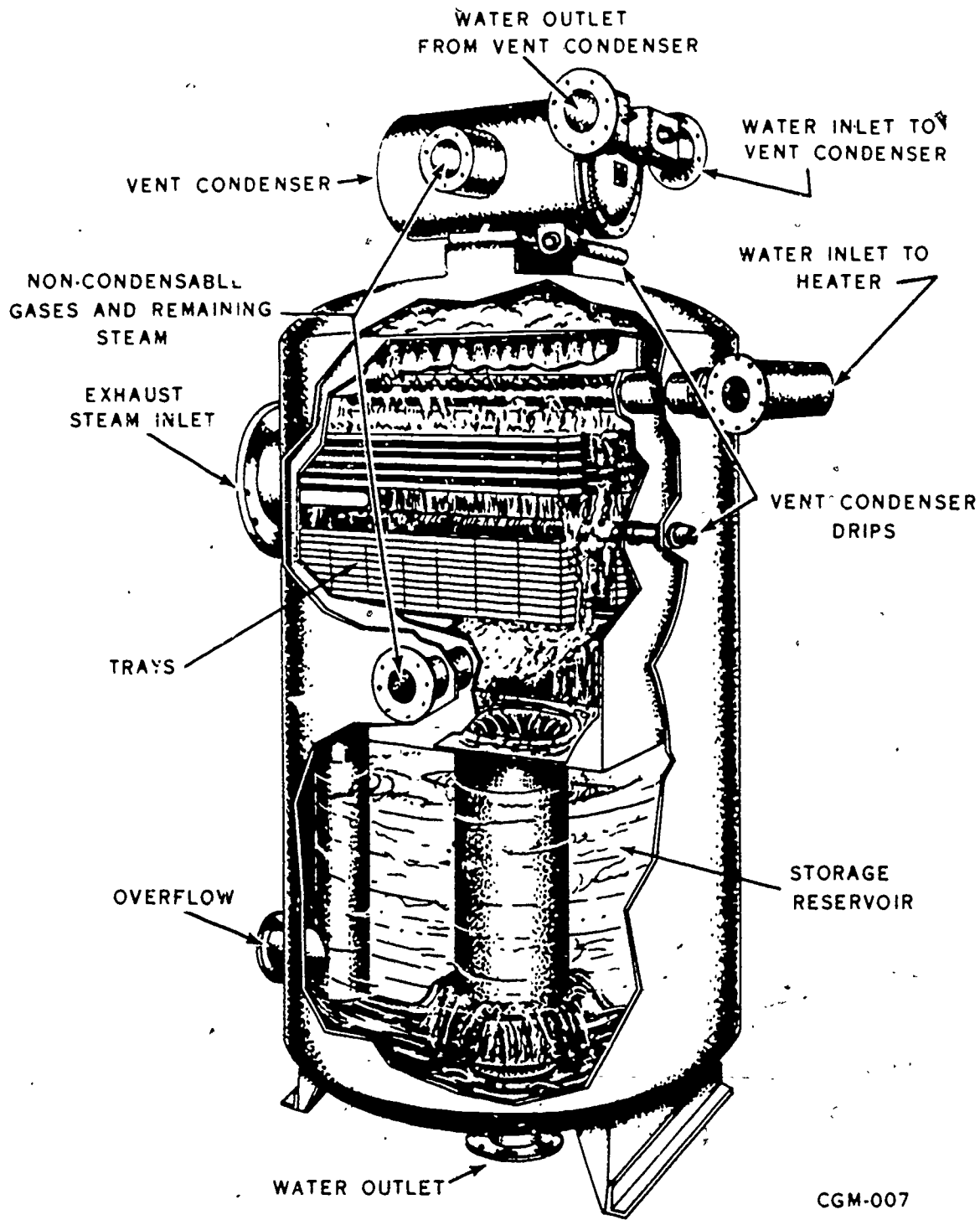
Closed-Type Heater. The closed-type feedwater heater is constructed so that the steam which heats the water and the water do not come into direct contact. They are

separated from each other by metal surfaces, such as tubes. The tank of the heater is supplied with steam and the water passes through tubes which are heated by the steam. Figure 4-7 illustrates a typical closed-type feedwater heater. The closed-type feedwater heaters are not very common on Air Force installations. This may be due to the fact that oxygen removal is not possible with this type of heater.

Economizer-Type Heater. The economizer is another unit used to heat feedwater. Economizers have horizontal tubes that are arranged in staggered, closely spaced rows. The tubes are placed in the path of the hot flue gases, and the water flows inside the tubes. As the hot flue gases pass around the tubes, the water inside is heated. The water can flow either upward or downward through the economizer. However, the upward flow is preferred when there is a possibility of steam being generated in the tubes. When a downward-flow economizer is used and some steam is generated, there is improper circulation through the unit. The maintenance of feedwater heaters and economizers normally includes removing the solid matter that accumulates in the unit; stopping steam and water leaks; and repairing inoperative traps, floats, valves, pumps, and other such associated equipment.

Open-Type Heater. The open-type feedwater heater, illustrated in figure 4-8, heats water by direct contact with the steam. The heater is usually cylindrical in shape and has an air vent located at the top. Steam enters the side of the heater through an oil separator. The water to be heated, usually from the condensate return, enters at the top and is distributed over the trays in rainfall fashion. The steam comes in direct contact with the water and is condensed as the water is heated. Oxygen and other gases are liberated to the atmosphere through the vent. Such heaters are provided with a sight glass that indicates the water level (not shown), a drain valve for draining the solid materials which settle to the bottom, and a regulating float valve in the supply line. Some heaters have provisions for skimming any foreign matter that collects on the surface of the water in the heater.

Deaerating Equipment. It is hard to discuss feedwater heaters without mentioning deaerators, since they are one and the same. The only difference is the amount of oxygen each removes from the water. The Heat Exchange Institute says that an "open heater" should remove all oxygen above 0.20 cc (cubic centimeters) per liter; "deaerating



CGM-007

Figure 4-9. Tray-type deaerating heater.

heaters," all in excess of 0.03 ml (milliliter) per liter; and "deaerators," all in excess of 0.005 ml per liter. The closed-type heaters cannot be classified as deaerators, because there is no way to liberate the oxygen. After studying the next subject on deaerators, you

will be able to go back and look at the closed heater in figure 4-7 and compare it to the open-type deaerators.

Deaerators. Deaerators and deaerating heaters are of the tray-type and the spray-type, depending upon the method used

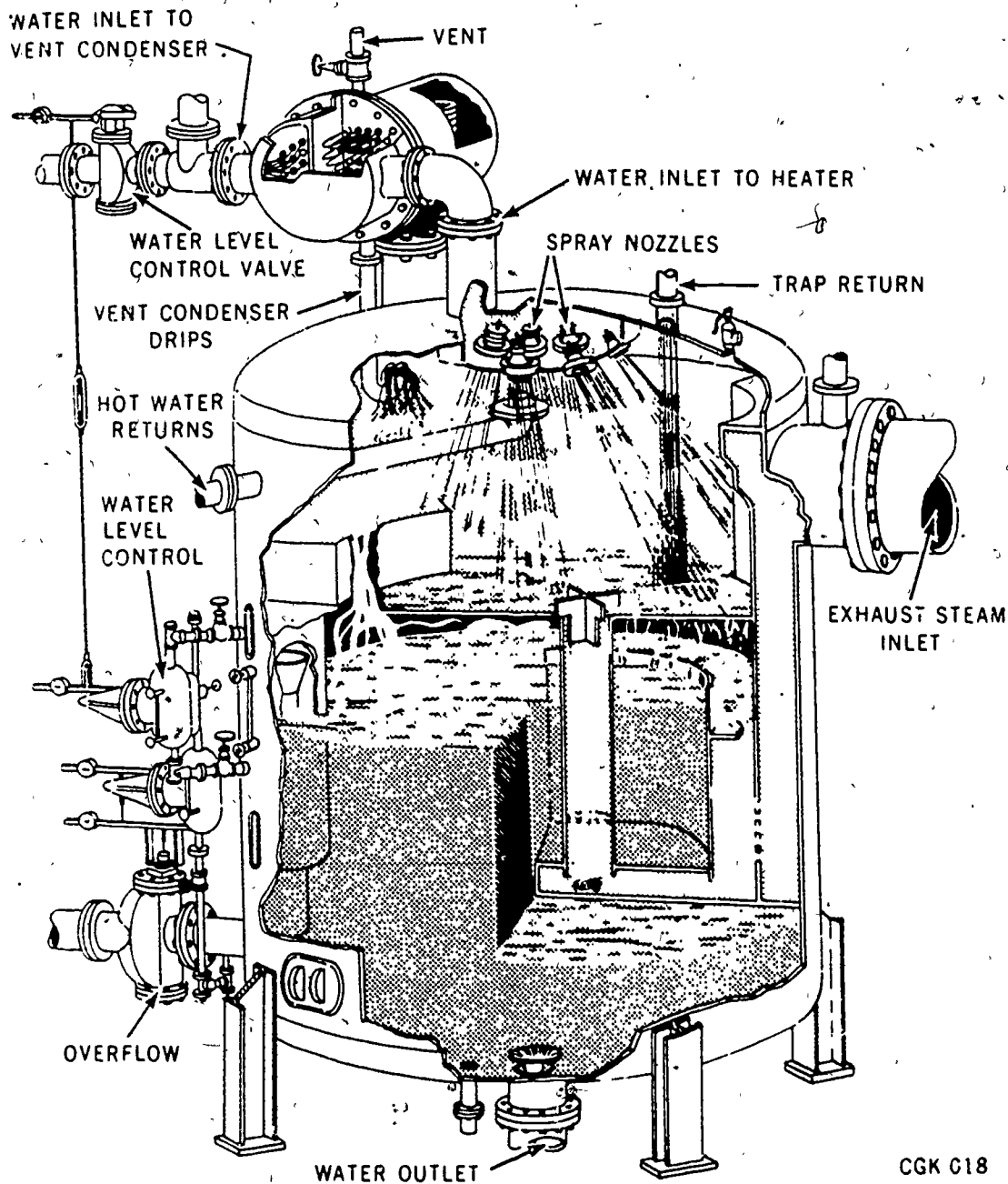


Figure 4-10. Spray-type deaerating heater.

to break up the water. Figure 4-9 illustrates a tray-type deaerating heater. During operation, the water passes through the vent condenser, enters the spray distributor, and is sprayed upward. The water breaks into small droplets and is forced into intimate contact with the steam. Most of the noncondensable gases are eliminated and the water is heated almost to a steaming temperature. When the water reaches the temperature of saturated steam, corresponding to the pressure in the

deaerator, the gases are completely liberated. The deaerated water then goes from the tray section into the storage reservoir.

A float assembly actuates the water control valves which control the water level in the tray-type deaerating heater. The steam enters through a nozzle in the side of the shell and flows through perforations in the top plate of the tray section. Here it meets the water sprayed upwards from the distributor. Most of the steam is condensed by the time it

passes through the tray stack. The remaining steam and any noncondensable gases enter the vent condenser. There the gases are discharged into the atmosphere, but the last of the steam is condensed and the water drains back into the unit.

In the spray-type deaerating heater, the water is broken up by spray valves instead of being allowed to cascade through a tray stack. Figure 4-10 illustrates a spray deaerating heater. The water is heated to the saturation temperature. Other than the difference in which the water is broken up, the spray deaerating heater works in much the same way as the tray type.

Exercises (683):

1. What is the purpose of feedwater heaters used in steam plants?
2. Why are vents installed in feedwater heaters?
3. How can you distinguish between a feedwater heater and a deaerator?
4. How many types of deaerating equipment are there? List them.

684. Specify the requirements for operating and servicing deaerators.

Preliminary Inspection. Prior to operating the deaerator, you should perform a preliminary inspection to insure the following requirements are fulfilled. (1) all installation, repair, and clean up work is completed, (2) installation tested for leaks; (3) relief valves in good operating condition and properly set; (4) steam and water inlet valves and water outlet valves closed, and (5) all valves for isolating controls and indicating and warning devices open. All other valves closed.

Starting Up. To start the deaerator operation, you should proceed as follows: (1) open the valve in the air vent line (or in vent condenser if present); (2) open the feedwater inlet valve slowly and gradually fill the water storage compartment of the heater, (3) check operation of the overflow device by leaving

the feedwater inlet valve open until the water storage compartment of the heater overflows, (4) close the water inlet valve and drain the heater; (5) close the drain valve; (6) gradually open the water inlet valve and slowly increase flow from 50 to 60 percent of design rate; (7) slowly open the steam inlet valve and check the steam pressure gage in the heater; (8) slowly open condensate return lines and trap discharge lines connected to the heater and allow the unit to fill to normal operating level, (9) as the water approaches operating level, completely open both the steam inlet valve and the water inlet valve and let the makeup regulating valve take control; (10) check alarms; (11) keep checking water temperature until the unit comes to within 2° F. of steam temperature; when it does, the unit is ready for service and the water outlet valve may be opened; and (12) throttle the vent valve so that there is always a short plume of steam discharging to the atmosphere.

Normal Operation. During normal operation, the storage water temperature should be at the saturated temperature of the steam at heater pressure. A wide variation from this temperature may indicate an insufficient vent rate, causing air and other noncondensable gases to accumulate in the heater. These will decrease heat and cause incomplete deaeration. Increase the vent rate by opening the air vent valve.

Shutting Down. To shut down the deaerator for servicing, you should proceed as follows: (1) close the steam inlet valve; (2) close all water and trap return inlet valves and steam reducing valve, if used; (3) fully open the vent valve; (4) close the water outlet valve; (5) if the unit will be out of service for a prolonged period or is to be inspected internally, drain the water from the heater; and (6) if steam is available, leave the unit in normal operating condition when it is out of service over weekends and holidays, and then when it is returned to service, hot and deaerated water will be available for boiler makeup and to start the plant.

Servicing Deaerators. To insure that deaerating equipment continues to accomplish the task for which it was installed, a program for inspecting and servicing the unit should be established and followed. Service inspection and maintenance actions can be set up on a daily and yearly basis.

Daily. Every day, you should check the deaerator for the following:

- a. Correct operation of relief valve, steam pressure reducing valve, overflow, controls, alarms, and steam pressure and temperature



indicators.

b. Steam and water leaks.

c. Faulty operation of oil separator (the oil separator should discharge into an open drain so its operation can be observed).

Yearly. Once a year, or more often under severe service conditions, clean the unit and inspect the following:

a. Spray valves, for corrosion, erosion, scaling, and proper seating.

b. Water discharge nozzles for clogging, corrosion, and wear.

c. Trays (on tray-type units), remove and inspect for corrosion, warping, and scaling.

d. Oil separator, inspect the interior of heater for evidence of oil, corrosion, or scaling.

e. Condition of relief, steam pressure reducing, float, vent, and overflow valves.

f. Condition of gage glass, controls, alarms, and instruments.

g. Condition of piping and valves.

h. Open and check the vent condenser for corrosion, wear, clogging of tubes, and sealing.

i. Check the condition of insulation for cracks and peeling.

j. After inspecting the heater as outlined above, repair or replace defective equipment and materials, as required. When replacing gaskets and packing, be sure to use the correct

type, size, and material.

Exercises (684):

1. What should be accomplished before a deaerator is placed into operation?
2. When is the deaerator ready to be placed into service?
3. What are the main procedures for operating a deaerator?
4. Why should a program for inspecting and servicing a deaerator be established?
5. Specify the servicing requirements that are on a daily basis for a deaerator.
6. What servicing requirements must be satisfied after the yearly inspection?

internal Water Treatment

REGARDLESS OF whether one is concerned with manpower or materials, well-laid plans will normally fall by the wayside if a means of control is not included in the program. This is particularly true of internal boiler water treatment. The most important factor in boiler water treatment for prevention of scale and corrosion is proper control of the chemicals used for treatment. Unless all chemicals are controlled within specified limits, the treatment is ineffective, steam contamination may result, and damage to the boiler will occur. Frequent testing, at stated intervals, is the only positive method for determining the concentration of chemicals in the boiler. By knowing the chemical concentration in the boiler, we are able to determine the amount of chemicals that will have to be added to maintain the specified limits.

In this chapter, we discuss the chemicals used and the function of each, methods of sampling boiler water, the safety precautions involved when working with chemicals, testing procedures for determining concentration of chemicals in boiler water, treatment for return line corrosion, how to maintain a water treatment log, chemical dosage for boiler water, and how to feed the chemicals into the boiler.

5-1. Water Sampling

Generally, as stated earlier, the makeup water that enters the boiler with the feedwater contains scale-forming calcium and magnesium elements. As a practical matter, these hardness elements cannot be kept in solution in the steaming boiler water. They will fall out and form a scale on the internal metal surfaces. A program for internal treatment is necessary to prevent this from happening. Part of this internal treatment includes knowing the chemicals used in the boiler water and how to draw a sample of water from the boiler.

685. Specify the factors that determine requirements for internal treatment of boiler water, and cite the water treatment requirements of commonly used boilers.

The basic requirements for treating boiler water vary with water quality and boiler construction, materials, operating pressure, capacity, and design. Since requirements for internal boiler water treatment vary with boiler type, a brief discussion on the classification of boilers is appropriate. Steam boilers are generally classified as high pressure, high horsepower; high pressure, low horsepower; low pressure, high horsepower, and low pressure, low horsepower. Steam boilers made of steel may operate at either high or low pressure. Cast iron boilers operate at low pressure. High-pressure boilers operate at pressures in excess of 15 psi. Low-pressure boilers operate at a pressure of 15 psi or less.

High-horsepower boiler plants are equipped with individual boilers rated at 100 horsepower or more. A boiler plant equipped with one boiler rated at 100 horsepower or more, and one or more boilers rated at less than 100 horsepower, is classified as a high-horsepower plant. High-horsepower boiler plants operate at high or low pressure. Low-horsepower boiler plants are equipped with individual boilers rated at less than 100 horsepower. The plants are operated at either high or low pressure. Type of chemical treatment, method of control, and application vary with the makeup water and the boiler. The following paragraphs serve as a general guide to treatment.

High-Pressure Steam Steel Boiler Treatment. These boilers are generally treated with caustic soda in combination with sodium metaphosphate and quebracho tannin.

Low-Pressure Steam Steel Boiler Treatment. These boilers are generally operated without makeup or blowdown and are, therefore, usually free from scaling and

corrosion troubles. If makeup is required for some reason, such as process requirements, corrosion and scale sometimes become problems. When they do, the boilers will be treated with caustic soda, sodium metaphosphate, and quebracho tannin. Control the treatment in the manner prescribed for these chemicals. If the boiler is operated with acidic or low-alkalinity waters, without makeup or blowdown, give it a sufficiently large dose of caustic soda to impart alkalinity in the range needed to prevent corrosion—PH 10.5 to 11.5.

Low-Pressure Cast Iron Boilers. Cast iron boilers that are assembled by joining sections with couplings are intended for closed heating systems that require little or no makeup water. This results in minimum scale formation and return line corrosion. These boilers are not fitted to remove the precipitated solids formed by the phosphate boiler water treatment. Therefore, the boilers are not to be treated with phosphates or other materials that will cause sludging and clogging of the sections. If excessive scale forms in the boiler, it may be removed by acid cleaning. However, the cleaning must be done only under competent supervision.

Exercises (685):

1. Identify the factors that determine the requirements for internal boiler water treatment.
2. When is a central heating plant considered to be a high-horsepower plant?
3. Identify the boiler water treatment requirements for a high-pressure steam steel boiler.
4. Identify the boiler water treatment requirements for a low-pressure steam steel boiler.
5. Why can't phosphate be used in low-pressure cast iron boilers?

686. List the chemicals used and specify their function in internal treatment.

Caustic Soda (NaOH). Addition of caustic soda to boiler water to maintain a concentration of 20-200 parts per million (ppm) will neutralize acid conditions and provide sufficient free hydroxyls to combine with the magnesium salts in water. The magnesium hydroxide produced by this reaction is a soft sludge and will not adhere to boiler water objectives. It keeps the boiler sludge fluid so that it is carried in the circulating water and can be removed by blowdown; it helps maintain effectiveness of certain chemicals such as phosphate, quebracho tannin; and it is required by some neutralizing amines for good volatility with the steam.

Phosphates (PO₄). A concentration of 30-60 ppm of phosphate should be maintained in the boiler water. When boiler water is treated with a phosphate chemical, the phosphate combines with calcium to precipitate calcium phosphate. Calcium phosphate forms as a finely divided, fluid sludge which can be carried by the boiler circulation and readily removed by blowdown. Since calcium phosphate is the least soluble of the calcium salts that form in a boiler water, phosphate control prevents the formation of all calcium scales, such as calcium carbonate or calcium sulfate. Maintenance of a satisfactory causticity in the boiler water is necessary with phosphate control, because calcium phosphate is more soluble if the water does not carry enough causticity and can form as a sticky sludge that will adhere to the boiler surfaces.

Tannin (Quebracho). Quebracho tannin contributes to several water treatment objectives. One of its principal contributions is to keep boiler sludge fluid so that it can be carried by the circulating boiler water and more readily removed by blowdown. This results from the colloidal property of tannin, which causes the sludge to form as finely divided particles easily borne by boiler circulation. Tannin decreases sludge accumulation and scale formation in the boiler. For this reason, it is frequently used as a supplement to caustic soda treatment to enhance removal of calcium phosphate sludge. Quebracho tannin has a corrosive control property in that it absorbs some of the dissolved oxygen and, more important, appears to form a protective film on steel. It should be used when detailed precautions for full protective corrosive controls are not practical or economical. Tannin also provides



smoother boiling with less carryover and, although Air Force boiler plants rarely present embrittlement problems, gives added assurance that such problems will not develop. The limit for tanning content of boiler water is a medium brown color (3M) as shown by the middle standard of the tannin color comparator. NOTE: Neither caustic soda nor sodium metaphosphate should be fed to the boiler through the boiler feedlines, particularly above 212° F., as deposition will occur. Such deposition can interfere with the action of valves, or the feed pump, or accumulate to such an extent as to interfere with flow in the feedlines.

Sodium Sulfite ($2Na_2SO_3$). In certain instances, some corrosion may persist even though sufficient causticity is carried and the feedwater deaerated. Sometimes, improved corrosion control is obtained by chemical treatment to remove the small quantities of oxygen left in the water after it has been deaerated mechanically. A few chemicals are available for this purpose; the most commonly used is sodium sulfite. When dissolved in water, it unites with oxygen to form sodium sulfate. If enough sodium sulfite is fed into a boiler, the chemical surplus maintained in the water will take up any oxygen that gets in and keeps the boiler water oxygen free. Normally, a concentration of about 20-40 ppm of sodium sulfite is maintained in the boiler water. This is enough to take up any oxygen that is likely to get into the boiler. Higher concentrations are unnecessary and wasteful.

Exercises (686):

1. List the chemicals that are commonly used in boiler water to prevent scale and corrosion.
2. What is the function of caustic soda when used for boiler water treatment?
3. Specify the function of the phosphates used for treating boiler water.
4. Tannin serves three functions in boiler water treatment. Cite them.

5. What is the function of sodium sulfite?

687. Identify boiler sampling points for drawing water.

For adequate treatment control, the boiler water tested must represent the true condition of the water in the boiler when it is operating. Exercise care in selecting the sampling point and the drawing-out method.

Water Sampling Points. If water-column connection to the boiler are short and direct, blow down the water column several times and draw a sample from the water-column blowdown connection. Install a 1/4-inch sampling connection ahead of the water column blowdown valve. For water-tube boilers, take the sample from either the front drum or the forward part of the upper rear drum. Continuous blowdown connections, properly located, make good sampling points. If the rear drum is close to the feedwater inlet, be sure that the sample is not diluted by feedwater. If any doubt exists as to the proper location of the sampling connection, contact the major command for assistance. For convenience and safety, extend all sampling connections to floor level.

Exercises (687):

1. What must be done to provide adequate boiler water treatment control?
2. Identify the boiler sampling points that can be used for drawing a water sample.

688. Describe the effect of cooling coils on water sampling and identify the two common cooling coils.

Cooling Coils. When boiler water is released from the pressure that was imposed on it, it will flash to steam. Since the steam will not carry the solids, a large concentration would exist in the condensate portion of the sample. If possible, draw the boiler water sample through a cooling coil that prevents it from flashing into steam. Several types of commercial cooling coils are available.

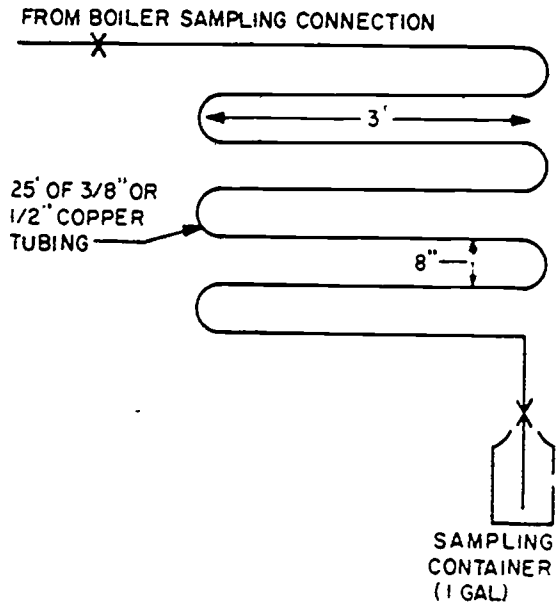


Figure 5-1. Air-cooled sampling coil.

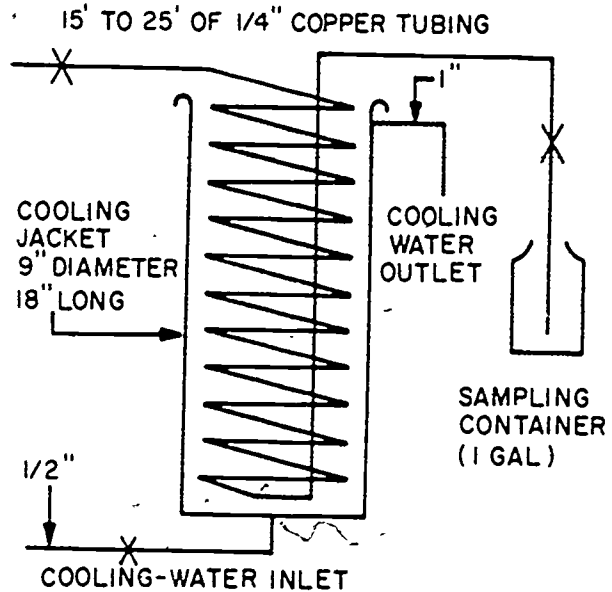


Figure 5-2. Water-cooled sampling coil.

Cooling coils can also be made easily in the plant.

Atmospherically cooled coil. About 25 feet of $\frac{3}{8}$ - or $\frac{1}{2}$ -inch copper tubing in the shape of a large helix and suspended in air makes a satisfactory air condenser (see fig. 5-1). This type of cooling coil will prevent the water from flashing to steam if the sample is not drawn too rapidly.

Water-cooled coil. Good results can be obtained with 15 to 25 feet of $\frac{1}{4}$ -inch copper tubing, formed into a coil approximately 6 inches in diameter and 10 inches long, and immersed in a bucket of cold water or a permanently connected cooling chamber. A common manifold permits the coil to serve two or more boilers (see fig. 5-2). The water-cooled coil allows a faster sampling time due to its greater cooling capacity.

Exercises (688):

1. Describe the effect that cooling coils have when used to draw a boiler water sample.
2. Identify the two common cooling coils used when drawing a water sample.

We have no set time to draw a boiler water sample, but all samples must be drawn before the regular blowdown and before chemicals are added. Unless otherwise specified, bring samples for all water analysis tests to room temperature. This is necessary to accurately determine concentrations of the chemicals available in the boiler and the dissolved solids content of the boiler water. All testing apparatus must be scrupulously clean, and kept and used in clean surroundings protected from dust and dirt.

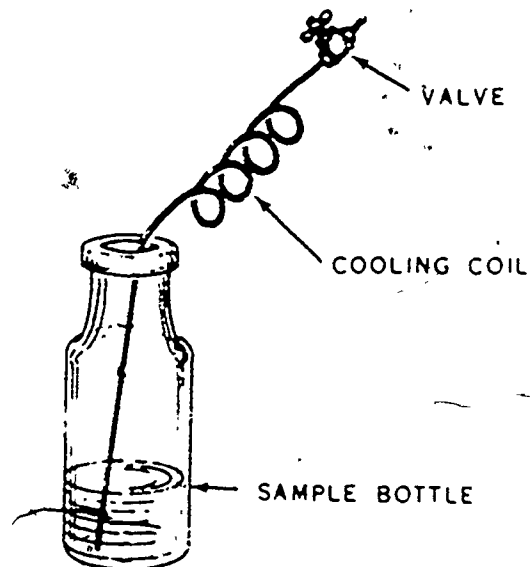
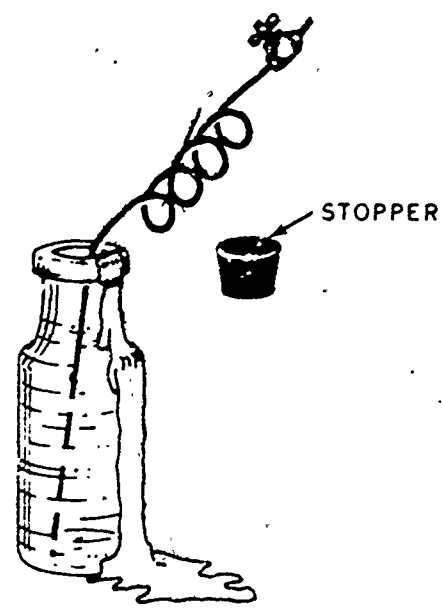


Figure 5-3. Sample bottle with sample line.

689. Cite the time element involved and the procedures for drawing a boiler water sample.

Sampling Procedures. Before collecting the sample, blow down all sampling lines and connections to sampling points to clear them of stagnant water. Avoid taking flash samples by using cooling coils and by drawing the sample slow enough to cool the water before it comes out the end of the sample line. Adjust the sampling line to reach the bottom of the bottle (see fig. 5-3). Draw the sample slowly but run it long enough to overflow the bottle top to expel all atmospheric air (see fig. 5-4). Then, stopper the bottle. This is necessary because the carbon dioxide and oxygen in the air can be absorbed and change the causticity and tannin concentrations of the sample. Never take the sample in a shallow pan or bucket, and do not expose it to the air any more than necessary. Extreme care must be exercised when drawing a boiler water sample, because a mistake at this time can affect the results of the boiler water tests. If the boiler water tests are wrong, the water treatment log will be wrong. Also, the wrong amount of chemicals will be placed in the boiler. Also, you may give the boiler too much blowdown, thus wasting chemicals, water, heat, time, and energy. A slight mistake at the beginning has a definite effect on the end; so insure sampling procedures are correct.



CNA-014

Figure 5-4. Sample bottle overflowing

faulty analytical techniques and to provide a quality check of reagents used for your local analysis.

Exercises (690):

1. At what time should a water sample be drawn from the boiler?
2. Cite the procedures for drawing a boiler water sample.

1. Where are boiler water samples sent?
2. What is the primary purpose of sending water samples to the Bureau of Mines?

690. Cite the primary purpose of sending water samples to the Bureau of Mines.

691. Specify the requirements for preparing and shipping a water sample.

Part of the procedure for proper treatment of boiler water entails periodic submission of samples to an adequately equipped laboratory. The Industrial Water Laboratory, US Bureau of Mines, College Park, Maryland, performs a check analysis on samples from Air Force installations. Samples of water from Government-operated boiler plants should be sent, for analysis, to the Bureau of Mines, as directed by AFR 91-7, *Heating*. The primary purpose of the analysis is to help installations engineer operating personnel to correct any

Preparing and Shipping Water Sample. Water samples are practically useless unless they are properly identified. Many times, samples lose their identity in transporting them from the point of collection to the testing laboratory. If the containers are properly labeled, there is less chance for any mixup in the analysis. Properly labeled samples also aid the chemist in filling out his reports as he tests the water. Figure 5-5 shows a typical label for a water sample. Information on the label should include the base or installation, building name and number, date, and boiler number. It is also

FURNISH THE FOLLOWING INFORMATION	
BOILER NUMBER	_____
PLANT NAME AND NUMBER	_____
DATE	_____
FOLDER NUMBER	_____

Figure 5-5. Label for sample bottle.

important that you collect a representative sample of boiler water in the containers furnished by the Bureau of Mines. The 24-ounce bottle is used for high-pressure boilers (above 15 psi), and a 2-ounce polyethylene plastic bottle is used for low-pressure boilers. Samples are submitted in accordance with the schedule based on the type of plant.

High-pressure plants. Submit a sample for each operating plant equipped with high-pressure boilers and one or more boilers of 100 horsepower or higher at monthly intervals. Submit a sample every 3 months for each operating boiler plant equipped with high-pressure boilers with less than 100 horsepower capacity. To even out the sample load and reduce the number of containers required, schedule one-third of these plants each month.

Low-pressure plants. Submit a sample for each low-pressure steam boiler plant treated with caustic soda at monthly intervals for individual boilers with a capacity of 100 horsepower or more and at 3-month intervals for individual boilers with less than 100 horsepower capacity. Submit a sample for each low-pressure plant, equipped with steel or cast iron boilers, that are treated with caustic soda combined with metaphosphate and tannin at monthly intervals for individual boilers with a capacity of 100 horsepower or more and at 3-month intervals for individual boilers with less than 100 horsepower capacity.

High-temperature water plants. Submit a sample for high temperature water plants (350° F. and above) at monthly intervals.

Assuming you have followed proper sampling procedures and you have affixed a completed label to the sample, your next step is to fill out the boiler water sample forms. After filling out Form BWS 3 and 3A, Data Sheet for High-Pressure Boiler Water Sample, or Form BWS 4 and 4A, Low-Pressure Boiler Water Sample, place them in the special

shipping container with the bottles. The shipping container for high pressure is furnished by the Bureau of Mines and is illustrated in figure 5-6. Low-pressure samples are shipped in a special box provided by the Bureau of Mines. It is a very good safety precaution to tie the container straps to prevent snooping and tape the bottle cork to prevent spillage in transit. Affix a franked label to the shipping container and send it to the Bureau of Mines.

Exercises (691):

1. How can you insure that samples taken from a boiler will not be mistaken as a sample from a different boiler?
2. What are the water sample preparing and shipping requirements for a high-pressure, high-horsepower plant?
3. What are the water sample preparing and shipping requirements for a high-pressure, low-horsepower plant?
4. How often is a water sample prepared and shipped for a low-pressure, high-horsepower plant?



CNA-012

Figure 5-6 Bureau of Mines shipping container

5. You have properly drawn a water sample in the proper size bottle and affixed a label to the bottle. Explain the additional preparation and shipping requirements.

5-2. Water Testing

The testing of boiler water to determine concentrations of constituents entails the use of chemicals, both acid and alkaline. Strict safety procedures must be followed. Do not allow yourself or coworkers to deviate from safety practices and boiler water testing standards.

692. Cite the safety precautions that should be followed when performing duties with or near acids and chemicals, and identify the main skin contaminants.

Many substances and materials used in Air Force operations may cause skin irritations, or dermatitis, to working personnel. Although most occupational skin afflictions are truly dermatitis infections, many of the substances that cause skin irritation, such as strong acids, act immediately on the skin to produce an acute effect, which is an injury rather than a dermatitis. Other more dilute substances, such as petroleum fuels, may cause dermatitis only after repeated or prolonged exposure and contact. Each individual has different reactions to dermatitis producing agents; some react quickly and violently while others show only the mild effects of an irritating substance. The oiliness and texture of the skin, hypersensitivity or allergies, susceptibility to other skin diseases, and even diet have a direct bearing on a person's reaction to dermatitis-producing contaminants.

Skin Contaminants. The most common dermatitis-producing agents that produce similar effects on all persons under like conditions are called general irritants. They include such substances and compounds as hydrochloric acid, sulfuric acid, sodium hydroxide, potassium hydroxide, and other acids and alkalines. Specific irritants are substances that will produce chronic inflammation or dermatitis after continued exposure. Paints, varnishes, cutting oils, petroleum fuels, and strong soaps are just a few of the many hundreds of materials that can be classified as specific skin irritants.

Safety Precautions. In the heating plant, as in any other plant or process, good housekeeping is the primary safety precaution. If the plant is not kept clean and orderly, the chances for accidents multiply. This is especially true when discussing water treatment, as some of the chemicals used to treat the water are dangerous if not handled properly. Boiler water tests for chemical residuals involve negligible quantities of acids and alkalines. The risk is small if spillage is avoided and bottles containing chemicals are not broken. Greater risks are involved in the handling of sulfuric acid in the hydrogen-zeolite demineralizing and direct-acid water treatment processes. The Manufacturing Chemists' Association has published a safety bulletin (*Chemical Safety Data Sheet, SD-20*) dealing with the methods for handling sulfuric acid. The following excerpt from the bulletin lists some of the recommended precautions. It deals primarily with sulfuric acid, but the precautions can be applied to all types of chemicals.

Although the handling of sulfuric acids presents various hazards, they can be avoided if the precautions set forth in the *Chemical Safety Data Sheet* are observed, as follows: (1) Do not permit dilute or strong sulfuric acid to come in contact with the eyes, skin, and clothing. (2) When handling acids, always wear goggles, face shields, gloves, and protective clothing. (3) Never add water or caustic solutions to sulfuric acid, as violent reactions can take place. Avoid spattering. If you must mix acid and water, always add the acid cautiously to the water. Never add water to the acid. (4) A competent individual should supervise all cleaning and repairing of tanks. Always observe instructions about entering and cleaning tanks, including the exact steps to be taken.

Exercises (692):

1. The most common dermatitis-producing agents, which produce similar effects on all persons under like conditions, are called what?
2. Identify some of the materials that can be classified as specific skin irritants.
3. What is the primary safety precaution to be followed when working with or near acids and chemicals?

493

UNITED STATES DEPARTMENT OF THE INTERIOR
BUREAU OF MINES
BOILER WATER SERVICE
COLLEGE PARK, MD.

SUBMIT
FOUR COPIES

ORDER BLANK—FOR BOILER WATER TESTING EQUIPMENT
PLEASE TYPE OR PRINT in Ink and submit to Boiler Water Service, Bureau of Mines, College Park, Md.

This order is placed by—
Officer
Name of station

Shipping address—if different from address at left:

City, State

Date order

Signed by

Test kits

Number
Ordered

- Test kit for phosphate
- Test kit for causticity
- Test kit for tannin by boiler water color
- Test kit—equipment used with conductivity meter
- Test kit for sodium sulfite
- Test kit for condensate pH
- Test kit for pH of boiler water by indicator paper

Test kit reagents:

- Causticity reagent No 1—qt
- Causticity reagent No 2—qt
- Decolorizing carbon—lb
- Comparator molybdate reagent—qt
- Stannous chloride—(conc.)—2 oz
- Phenolphthalein indicator—4 oz
- Sulfuric acid 0.5N—qt
- Potassium chromate indicator—4 oz
- Standard silver nitrate reagent—qt
- Potato or arrowroot starch—2 oz
- Thymol—8-ml vial
- Hydrochloric acid 3N—qt
- Standard iodate-iodide reagent—pt.
- Phosphate test solution—45 ppm—qt.
- Condensate pH indicator—4 oz
- Conductivity neutralizing solution—pt.
- Conductivity meter test solution—qt.
- Indicator paper, pH 11 to 12—vial
- Indicator paper pH 10 to 12—vial

Test kit replacement parts:

- Package filter paper—11 cm
- Glass funnel
- Phosphate comparator combination mixing tube
- Phosphate comparator bottle 20 ml
- 1-oz indicator dropping bottle
- 5-ml dropper
- Square tube for improved tannin kit
- Dropper—7-in with bulb
- Bulb for dropper
- Marked test tube for causticity test
- Plain test tube
- Test tube—200 mm x 38 mm
- Armored thermometer—0° to 150° F
- Rubber stopper for test tube, No. 3.

Test kit replacement parts:

Number
Ordered

- Test tube brush
- Spoon—1/2-teaspoon size
- Test tube clamp
- Stirring rod glass—9 in
- 250-ml glass-stoppered bottle
- 2-oz bottle
- Test tube rack
- Rubber stopper for combination mixing tube
- 50-ml beaker
- 100-ml beaker

Boiler water sampling containers:

- High-pressure boiler water sampling container—24-oz bottle
- Low-pressure boiler water sampling container—2 oz. bottle

Publications, Forms, and Instructions:

- Questions and Answers, Boiler Feed-water Conditioning Handbook
- Boiler Water Treatment Manual for Federal Plant Operators
- Instructions for Test Kit for Phosphate, BWS 15
- Instructions for Test Kit for Causticity, BWS 16
- Instructions for Test Kit for Tannin, BWS 9A
- Instructions for Determining Dissolved Solids in Boiler Water by Electrical Conductivity, BWS 21
- Instructions for Test Kit for Sulfite, BWS 7
- Instructions for Test Kit for Condensate pH, BWS 18
- Instructions for pH of Boiler Water by Indicator Paper, BWS 20
- Instructions for Determining Chloride, BWS 14
- Instructions for Deaerating Heater Performance Test, BWS 23
- Questionnaire on Boiler Feed-water Conditioning BWS 11.
- Labels for reagents (specify)
- Order blank, BWS 6—Pac.

Figure 5-7. Water testing equipment order blank.

4. What safety precautions should be followed when performing duties with or near acids and chemicals?

693. Specify the types of equipment, test kits, and reagents used for boiler water testing.

Water Testing Facilities. An arrangement with the Bureau of Mines, Department of the Interior, permits Air Force activities to obtain the necessary test kits and reagents by direct request to the Bureau of Mines, Industrial Water Laboratory, College Park, Maryland, 20740. Kits are available to test for causticity, phosphate, tannin, pH of boiler water (low-pressure boilers), pH of return condensate, and sodium sulfite. Figure 5-7 identifies the tests kits available from the Bureau of Mines. You use Form BWS 6 for requesting supplies for local laboratories. Also, the form shows the test kit reagents, test kit replacement parts, boiler water sampling containers, and publications, forms, and instructions.

Adequate space and equipment should be made available in the plant to facilitate testing. In addition to the equipment obtained from the Bureau of Mines, the equipment in the plant should include the following basic items of furniture: sink, preferably with an integral drain board; shelf; cabinet; a unit for the distillation of water, if distilled or demineralized water is not available from other sources. Items for cleaning and maintaining laboratory equipment should also be available.

Exercises (693):

1. Specify the types of equipment used for boiler water testing that is available from the Bureau of Mines in kit form.
2. Identify the reagents used for boiler water testing.
3. List the equipment used with boiler water testing that should be located at the plant.

694. Cite the purpose of testing boiler water for sodium sulfite.

The sodium sulfite test is performed to measure sodium sulfite content in the boiler water when this type of treatment is used. Sodium sulfite acts with oxygen very rapidly in the hot boiler water to form sodium sulfate. Sodium sulfite treatment is used to supplement mechanical methods and tannin as oxygen removal agents. When the remaining dissolved oxygen content remains high and sodium sulfite treatment is instituted, a concentration between 20 and 40 parts per million is usually considered satisfactory. The purpose of making the sodium sulfite test is to insure this concentration is maintained by adding or stopping chemical feed to the boiler.

Exercises (694):

1. What are the chemical concentration limits for sodium sulfite in boiler water?
2. Cite the purpose of testing boiler water to determine the concentration of sodium sulfite.

695. Specify the procedures for testing boiler water for sodium sulfite.

Sodium Sulfite Test. Since oxygen in the air will combine with sodium sulfite, the sample must be kept from contact with the air as much as possible to prevent low readings. Collect a separate sample, using the boiler water sample cooler with the line reaching to the bottom of the sampling bottle. Allow the boiler water to run until a few bottlefuls overflow to waste. Cool the sample to 70° F. or below; then analyze it immediately to prevent reaction with the air. **CAUTION:** If the procedures below differ from those of the supplier of equipment or reagent, use the supplier's procedures.

Preparation of starch indicator. Prepare the starch indicator in the following manner:

- a. Measure out a level 1/4 teaspoonful of starch and place it in the 50-ml beaker.
- b. Add a few milliliters of distilled water and stir the starch into a thin paste with the glass end of the stirring rod.
- c. Put 50 ml of distilled water into the

150-ml beaker. (For convenience, mark the 150-ml beaker at the 50-ml point, or measure 50 ml by filling a marked test tube with distilled water to the fourth mark above the long mark.)

d. Bring the water in the 150-ml beaker to a boil by any convenient method.

e. Remove the heat source and immediately pour the starch paste from the 50-ml beaker into the boiling water while stirring the solution.

f. Put a crystal of thymol into the starch solution and stir. (The starch solution soon loses its sensitivity as an indicator; the thymol preserves it for about 2 weeks. Be sure to date the starch when it is prepared.) After the solution has cooled, pour off the surface scum and transfer 30 ml of the solution to the indicator dropping bottle.

Procedure for running a sodium sulfite test. Following are the step-by-step procedures for running a sodium sulfite test.

a. With the acid-dropping bottle dropper, transfer two 1/2-ml portions of 3N hydrochloric acid to a clean, marked test tube.

b. From the starch-dropping bottle, transfer 1/2 ml of starch to the marked test tube with the acid.

c. Without disturbing any settled sludge in the sample, add enough sample to bring the level in the tube up to the first mark (25 ml). Stir the mixture with the rubber-tipped end of the stirring rod.

d. Fill the dropper with standard potassium iodate-iodide reagent from the stock bottle by sucking it up with the rubber bulb. (The dropper must be kept clean and reserved for this test only.)

e. Add the reagent to the mixture, one drop at a time, counting the number of drops and stirring after each addition until the mixture turns blue and stirring does not remove the color. (The standard iodate-iodide reagent reacts with sodium sulfite in the mixture. When all the sodium sulfite has been consumed by the reagent, the mixture turns blue, indicating reaction of excess reagent with the starch.) For this step, if the test tube is supported and the stirring rod placed in the tube, the reagent can be added with one hand while the mixture is stirred with the other.

f. Figure the sodium sulfite concentration in the boiler water by multiplying by 5 the total number, less 1, of drops of reagent used. (Each drop of reagent, except the last one, indicates 5 ppm of sodium sulfite in the sample.)

Exercises (695):

1. At what temperature should the water sample be to perform a sodium sulfite test?

2. Why does starch have to be made fresh on a continuing basis?

3. What are the procedures for testing boiler water for sodium sulfite?

696. State the concentration limits for causticity in boiler water, and cite the purpose of testing boiler water for causticity.

The limits for the causticity concentration are between 20 ppm and 200 ppm. Otherwise, caustic soda (NaOH) is added to the boiler water to maintain the causticity within these limits. A causticity concentration within these limits will neutralize acid materials in the water. In addition to the neutralizing action, the free hydroxide combines with magnesium salts to form magnesium hydroxide, a soft finely divided sludge which can easily be removed from the boiler by blowdown. Alkaline water will usually prevent corrosion in the boiler. The causticity test is used to determine the amount of free causticity or hydroxide (OH) in the boiler water.

Exercises (696):

1. State the concentration limits for causticity in boiler water.

2. Cite the purpose of testing boiler water for causticity.

697. List the procedures for testing boiler water for causticity.

Causticity Test. For this test, start with a warm boiler water sample at about 160° F. It can be reheated by placing the sample-collecting container in a stream of hot boiler water drawn through the boiler water

cooler connection, or portions of the boiler water sample may be tested in test tubes set in heated water in a container such as a beaker or a pot. CAUTION: To minimize absorption of CO₂, expose samples to the air only when absolutely necessary.

Fill two marked test tubes to the first mark (25 ml) with some of the original boiler water sample, taking care not to disturb the settled sludge in the container. (It is important that as little sludge as possible be transferred from the sample-collecting container to the test tubes.)

Shake causticity reagent No. 1 thoroughly and add enough of it to each of the two marked tubes to bring fluid levels to the second, or long, mark (30 ml). Stir each with the stirring rod, kept clean and reserved for the causticity test only. Stopper both tubes and let them stand until any sludge formed has settled to the bottom. The sludge carries with it much of the tannin or other colored matter in the solution; settling takes only a few minutes if the sample is warm. Without disturbing the sludge at the bottom, pour enough solution from the tubes into the third marked tube to fill it to the second, or long, mark (30 ml). Discard the mixture left in the first two tubes. If the sample in the third tube is still warm, cool it by letting cold water run on the outside of the tube. If causticity is present, the sample will turn pink. Sometimes the pink color can be intensified by adding two drops of phenolphthalein from the indicator or dropping bottle to the sample in the tube. Stir the solution. If it is not pink, the causticity in the boiler water is zero. In this case, the test is finished.

If the mixture turns pink, add causticity reagent No. 2 (standard 1/30 normal acid), using the clean 8-inch dropper reserved for the causticity test only. To add causticity reagent No. 2, draw it from the reagent bottle into the dropper with the rubber bulb, and add it drop by drop to the test tube. After each addition, stir the mixture with a stirring rod. When sufficient reagent has been added, the pink color disappears; usually the change point is very sharp. As soon as the pink color just fades out, stop adding reagent.

The amount of causticity reagent No. 2 required to make the pink color disappear indicates the concentration of hydroxide (OH) or causticity in the boiler water. The amount of reagent used is shown by the marks on the test tube above the long mark (30 ml). The distance between any two marks on the test tube equals 5 ml; readings less than 5 ml can be estimated. For example, if only three-fifths of the distance between the

long mark and the next mark above was filled, then 3 ml were added. If the distance filled was past one mark plus three-fifths of the distance to the next, then 5 + 3 = 8 ml were used. To obtain the actual ppm of hydroxide or causticity shown by the test, multiply the number of ml by 23. Thus, for 8 ml of causticity reagent No. 2, there are 8 x 23 = 184 ppm hydroxide or causticity in the water.

Exercises (697):

1. Why is it important to expose the sample to the air only when absolutely necessary?
2. List the procedures for testing boiler water for causticity.

698. Cite the purpose of testing boiler water for phosphate.

Maintaining a phosphate level between 30 and 60 parts per million, by addition of sodium metaphosphate, will result in the sodium metaphosphate combining with some of the free sodium (formed by the addition of caustic soda) forming trisodium phosphate. The trisodium phosphate combines with calcium salts in the water to form tricalcium phosphate, a soft, nonadhering, finely divided sludge which can easily be removed from the boiler by blowdown. The phosphate test is used to determine the amount of soluble phosphate in the boiler water.

Exercises (698):

1. What should the concentration of phosphate be in boiler water?
2. What is the purpose of testing boiler water for phosphate?

699. List the procedure for testing boiler water for phosphate.

Phosphate Test. To make this test, fill two test tubes from the Bureau of Mines test kit about half full of water taken from the boiler

water sample container. Be careful not to disturb the sediment in the bottom of the sample container. After the water is in the test tubes, mix one-fourth of a teaspoon of decolorizing carbon into the water in each test tube to remove any organic color existing in the water. Then filter the water-decolorizing carbon solution into the test kit comparator mixing tube and fill to the first mark on the mixing tube.

Now, add 10 milliliters of comparator molybdate to the solution in the mixing tube. This fills it to the second, or 15-milliliter, mark. After this has been done, add fresh dilute stannous chloride to bring the level to the 17.5-milliliter mark. Mix the stannous chloride according to the instructions received with the phosphate test kit from the Bureau of Mines. When you have added dilute stannous chloride to the solution of water and comparator molybdate reagent, the solution should turn blue if there is phosphate in the boiler water.

Use a comparator to determine the concentration of the phosphate. The comparator is a wooden block with three windows. The left window has a light blue liquid representing 30 ppm phosphate, and the right side has a dark blue liquid representing 60 ppm. Place the test tube containing the test solution in the center slot of the comparator block. If the color comes between the two standards of 30 to 60 ppm in the comparator, the boiler water is satisfactory. However, if the color is lighter than the 30-ppm standard, you should add phosphate to the boiler. If the color is darker than the 60-ppm standard, the phosphate concentration is too high.

Exercises (699):

1. Why is decolorizing carbon used in the phosphate test?
2. List the procedures for testing boiler water for phosphate.

700. Cite the purpose of testing boiler water for tannin.

Tannin acts as an oxygen absorber. Due to its colloidal action, it can make the sludge form as very finely divided particles, thus

being more fluid. This sludge is carried by the circulating boiler water and is removed quite readily by boiler blowdown. The limit for tannin content of boiler water is a No. 3, medium brown color, as shown by the middle standard of the tannin color comparator. The tannin test is made to determine the approximate concentration of tannin in the boiler water.

Exercises (700):

1. For ordinary boiler water conditions, when is the tannin dosage usually considered satisfactory?
2. Cite the purpose of testing boiler water for tannin.

701. Cite the procedures for testing boiler water for tannin.

Tannin Test. Without disturbing any settled sludge in the sample, fill a plain test tube to within an inch or two of the top with the boiler water being tested. The boiler water should preferably be cooled slightly. Fold a filter paper and place it in a funnel without wetting it down. Place the funnel in a square test tube in the comparator and filter the sample from the plain test tube until it is nearly filled. Remove the square test tube and note the appearance of the filtered boiler water; it should be almost free of suspended solids or sludge; refilter it, using the same funnel and filter paper until it does come out free of solids. Set the square test tube containing the filtered sample back in the middle slot of the comparator. Compare the color of the sample with the five colors on the tannin color standard, viewing against a source of very bright daylight. The color standard that most closely matches the color of the filtered sample gives the tannin color of the boiler water. For ordinary boiler water conditions, the tannin dosage is usually satisfactory if it maintains a medium tannin color in the boiler water; that is, the filtered boiler water matches the No. 3 tannin color standard.

Exercises (701):

1. Why is filter paper used when making a tannin test?



2. List the procedures for testing boiler water for tannin.

tube (about 5 inches from the top) can be marked with a file or crayon. If desired, a rack or other support for the tube can be made at the boiler plant.

702. State the specified concentration limits for dissolved solids in boiler water, and cite the purpose of testing boiler water for dissolved solids.

Connect the terminals of the conductivity cell to the conductivity meter. Plug the instrument cord into a 105- to 130-volt, 50- to 60-cycle AC outlet and turn on the instrument switch. Allow the instrument to warm up.

The specified limits for dissolved solids in boiler water are between 1000 and 4000 parts per million. The electrical conductivity method of testing is a simple and rapid way to determine dissolved solids content. It is based on the fact that water containing ionizable solids will conduct electricity. The higher the concentration of ionizable salts, the greater the electrical conductance. Pure water, free from ionizable solids, possesses very low conductance and, therefore, very high resistance. The instrument measures the specific conductance of a water sample. The conductance value can then be converted to parts per million dissolved solids concentration. The dissolved solids test is used to determine the concentration of soluble salts in boiler water and as a control to determine the amount and frequency of boiler blowdown.

Half fill a clean 200-mm x 38-mm test tube with distilled water. Wash the conductivity cell by immersing it in distilled water, but do not immerse the cable. Move the cell up and down several times in the distilled water; then remove it and shake off adhering water. Discard the distilled water in the tube. Immerse the cell in the solution being tested until the level of the solution is at least 1/2 inch above the vent holes. Move up and down several times to release bubbles which may adhere to the cell.

Exercises (702):

Set the thermometer in the test tube solution. When the thermometer reading comes to rest, set the temperature adjustment knob of the instrument to the same reading as the thermometer. Remove the thermometer from the solution. Set the cell so that it is as nearly centered in the test tube as possible.

1. State the specified concentration limits for dissolved solids in boiler water.

When the electron tube brightness indicates that the instrument has warmed up, rotate the instrument dial until the dark segment of the electron tube reaches its widest opening and a sharp shadow appears. The RD-P104 solubridge (conductivity meter) reads specific conductance in micromhos/cm at 77° F. When reading the scale, note that each small division between 500 and 4000 represents 100 micromhos/cm and each small division between 4000 and 7000 is 200 micromhos/cm.

2. What is the purpose of testing boiler water for dissolved solids?

Clean the cell by rinsing it in fresh distilled water. When the cell is not in use, keep it immersed in distilled water in a 200-mm x 38-mm test tube.

703. Specify the procedures for testing boiler water for dissolved solids.

To convert the specific conductance reading to concentration in parts per million, multiply it by the conversion factor listed below that corresponds to the tannin number (color) of your sample. These factors would be used with any instrument with a base temperature of 77° F. or 25° C. which has been calibrated to give readings of specific conductance in micromhos/cm.

Dissolved Solids Test. Set aside the boiler water sample until it reaches room temperature and the sludge settles to the bottom. Without disturbing settled sludge, rinse a clean test tube (200 mm x 33 mm) with the sample; then pour in about 60 ml of the sample. Add two dropperfuls (filled to the mark) of conductivity-neutralizing solution, or if the sample causticity is above 400, add three dropperfuls. Stopper and invert several times to mix. NOTE: The 60-ml point on the

Tannin Number	Factor
0	0.7
1	0.8
2, 3	0.9
4, 5	1.0



Example: If the sample has a tannin number of 1 and a specific conductance of 3100 micromhos/cm, the concentration in the sample is: 3100×0.8 , or 2480 ppm.

Exercises (703):

1. How are bubbles removed from the cell of the conductivity meter?
2. When running a dissolved solids test, how do you know when the correct reading is reached?
3. How is the specific conductance of the water converted to parts per million?
4. What are the procedures for testing boiler water for dissolved solids?

704. Cite the purpose of amine treatment.

Corrosion in condensate return lines and associated equipment is a problem common at many Air Force bases. The causticity in the boiler water is not volatile and ordinarily only small amounts, if any, goes over with the steam. However, carbon dioxide (CO₂) gas does go over with the steam and dissolves in the condensate. It causes carbonic acid, lowers the pH of the return condensate, and makes it acid. The carbon dioxide is more corrosive than the oxygen, which leaks in at pipe connections, pumps, etc. But, when both are present, the problem is intensified and a corrosion problem is likely to exist. Acid corrosion usually grooves and channels the bottom of the pipe; frequently, it is most pronounced just beyond the traps of heat exchangers or radiators. While carbonic acid will groove the bottom of the pipe, oxygen normally pits the entire circumference of the pipe. Return line corrosion can be partially controlled with neutralizing amine treatment.

Exercises (704):

1. How does carbonic acid get into the condensate return line?

2. Cite the purpose of amine treatment.

705. Name the types of amines used to control return line corrosion.

Most condensate corrosion problems are caused by carbonic acid in the condensate. The carbonic acid is derived from mineral carbonate in feedwater makeup. Therefore, caustic soda rather than soda ash, which is also a carbonic acid source, is used for internal boiler water treatment. To neutralize the condensate carbonic acid, treat the boiler water with an alkaline material that carries over with steam. A group of volatile, alkaline compounds called "amines" satisfies this requirement. When fed into the boiler water, the amines volatilize to form a gas which flows over with the steam and returns with the condensate to the boiler where it is reused. Loss of condensate results in loss of chemical. The alkalinity of the amine builds up the condensate pH and, effectively used, can control return line corrosion by keeping the pH just on the alkaline side (about 7.0 to 7.5). The neutralizing amines approved for Air Force use are cyclohexylamine and morpholine.

Cyclohexylamine. Two grades of cyclohexylamine are available: a water solution which is 60 percent cyclohexylamine, and a special grade which is 98 percent cyclohexylamine. The 98-percent grade is more economical; however, since it is about as flammable as alcohol, it must be diluted with an equal volume of water when received at the plant. Cyclohexylamines are sold under various trade names and may vary somewhat in concentration percentages. Cyclohexylamine is caustic and harmful to the skin. Handle it carefully to prevent spilling it on the skin or breathing the fumes excessively. When used in direct contact cookers, cyclohexylamine may be used if it does not exceed 10 ppm in the steam. DO NOT use such steam where it will contact milk products.

Morpholine. Morpholine is a neutralizing amine sold in a 91-percent solution. It is less volatile than cyclohexylamine; consequently, it is used in plants that operate at high pressures and ratings—usually above 50 psi. In situations in which its use is applicable, it has one distinct advantage. It releases CO₂ more readily than cyclohexylamine does, and, in a properly vented system with a good



deaerating heater, has a higher recycling capacity. The same precautions and procedures set forth for cyclohexylamine apply also to morpholine.

Exercises (705):

1. To adequately control corrosion of condensate return lines, what pH reading should be maintained?
2. Name the types of amines used to control return line corrosion.

706. List and describe the methods used to test the pH of condensate return water.

The value of pH indicates the degree of acidity or alkalinity of a sample. A pH of 7.0 represents the neutral point; lesser values denote acidity, and greater values indicate alkalinity. The pH test should be made as soon as possible after taking the sample. Expose the sample to air as little as possible to minimize absorption of CO₂. Several methods of determining pH exist.

Colorimetric Method. The Taylor comparator, which is sold by chemical supply sources in kit form, represents the first method. It is simple, but to assure accuracy, the indicator fluid must be standardized periodically.

Bureau of Mines Test Kit Method for Boiler Water pH. This test is designed primarily to test boiler water pH so it can be controlled between 10.5 and 11.5 on the pH scale.

Test equipment. The test kit includes two vials of indicator paper (Hydrion pH₁₀ to 12); two vials of indicator paper (Hydrion C ph, 11 to 12); one 50-ml beaker; and one 2-ounce bottle.

Test procedure. Fill the beaker about three-fourths full with sample water. Remove a strip of pH 10 to 12 indicator paper from the vial and dip it into the sample in the beaker, leaving it immersed for 30 seconds. If the color of the paper does not change, or changes to yellow or very light orange, the pH of the sample is very low. If the paper turns orange or red, the pH is either satisfactory or too high. Remove a strip of pH 11 to 12 indicator paper from the vial and dip it into the sample in the beaker, leaving it immersed for 30 seconds. If the color of the paper remains the same, or changes to light blue, the

pH is satisfactory. If the paper turns deep blue, the pH is higher than necessary. In most instances, a satisfactory pH indicates a boiler water pH in the range of 10.5 to 11.5.

Bureau of Mines Test Kit Method for Condensate pH. This-kit is designed to control the dosage of volatile neutralizing amines, such as cyclohexylamine and morpholine.

Taking the sample. For this test, take the sample from a point in the return piping near which condensation takes place, such as after a trap, or preferably where return line corrosion is known to occur. The sample must be representative of water flowing in the return lines. Water taken from the return tank, especially of large installations, generally shows a higher pH. Do not take the sample from a collecting tank if the tank receives other water, such as makeup.

Testing equipment. The test kit includes one 4-ounce brown bottle of condensate pH indicator; one 1-ounce indicator bottle, with dropper marked at 0.5 ml; one 100-ml beaker marked at 50-ml, and one 9-inch glass stirring rod.

Test procedure. Fill the testing beaker to the 50-ml mark with a freshly drawn sample. The sample need not be cooled, but it should be collected slowly to reduce flashing. With the marked dropper, add 1/2-ml of pH indicator solution to the sample in the beaker and stir the solution. The resulting color indicates the pH. Green shows an acid condensate; light pink, a neutral or slightly alkaline pH, which is normally satisfactory. red or purple, a higher-than-necessary pH.

Exercises (706):

1. List the methods used to determine the pH of water.
2. Describe the methods used to test the pH of boiler water and condensate return water when utilizing Bureau of Mines test kits.

5-3. Water Treatment Logs

The purpose of logs is to provide a record of water treatment administered to boilers installed in all Air Force installations.

707. Explain the procedures for maintaining the water treatment log.



Air Force Form 1459, Water Treatment Operating Log for Steam and Hot Water Boilers, is used to record daily results of analyses, chemicals used, blowdown, and other pertinent information. This form is to be used for recording water treatment data for all steam and hot water boilers that need chemical treatment. These logs are active as long as the base or installation is active. The water treatment logs for a plant are prepared and kept current at a central boiler operation area. This report permits technical review of current performance and comparison of performance over a long period. Accumulated reports show variations due to changes in season and methods of operation.

Preparation Procedures. This log will be prepared in duplicate (original and carbon) by the engineer in charge at the central heating plant. The log will be posted daily and forwarded at the end of the month to the base civil engineer for review and approval. After approval, the base civil engineer will forward the second (or carbon copy) to the major command civil engineer not later than the 20th of the month following the reporting period. Existing local directives may require the logs to pass through intermediate headquarters prior to being received by the major command. No logs will be forwarded to Headquarters USAF. The original copy of these logs provides the CE unit with a continuous record of boiler plant operations. The following procedures identify the entries for preparation of the log shown in figure 5-8.

Columns A through C. Use these columns for steam boilers only. Enter in the appropriate column the parts per million of phosphate that is determined with the phosphate test.

Column D. Enter the number of milliliters of causticity reagent No. 2 that was required to destroy the pink color during the causticity test.

Columns E through G. These columns are required for steam boilers. Multiply the value entered in column D by 23 to obtain the result in parts per million hydroxide (OH) and enter in appropriate column.

Column 6. This column is for steam boilers only. Enter the number for the proper color designation for the filtered sample of boiler water as determined with the color standards. Colors are (1) very light, (2) light, (3) medium, (4) dark, and (5) very dark.

Column I. Enter the reading obtained from the conductivity meter used when testing for dissolved solids.

Column J. Enter the dissolved solids in parts per million as calculated by multiplying

the conductivity meter reading by the proper tannin conversion factor.

Column K. Enter the parts per million sulfite content as determined by the test for sodium sulfite. High temperature water heating systems require 20 to 40 parts per million sodium sulfite. This chemical is not to be used in steam boilers except on approval by major command.

Column L. For high temperature water systems (350° F. water and higher). Enter the pH of the sample tested. Required range is 9.3 to 9.9.

Columns M through R. Enter the total number of pounds of each chemical added to the boiler or hot water generator during the day. Use the blank columns for chemicals added other than those listed in columns M through P, such as amines.

Column S. Enter the pH of the condensate return water. If a pH meter is not available, use the Bureau of Mines test kit and enter the color reading.

Column T. Determine the total number of gallons of blowdown water and enter the amount in this column. Do not blow down high temperature water systems.

Column U. Enter the total gallons of makeup water.

Column V. Enter the hardness in parts per million of the makeup water.

Columns W through AA. These columns are used for central heating plants that have ion exchangers in conjunction with their operation for sole or partial use of the heating plant. Enter in columns W, X, and Y the quantity of water processed daily in each ion exchanger. Enter in column Z the total quantity in gallons of water processed to the heating plant through all exchangers. Enter in column AA the quantity and type of chemical (salt, acid, or alkali) used to regenerate the ion exchangers.

Remarks. The Remarks space may be used to indicate any unusual conditions or to report special data.

Exercises (707):

1. Which Air Force form is used to record pertinent water treatment information?
2. When does the water treatment log have to be submitted to the major command civil engineer?



3. Explain the procedures for maintaining the boiler water treatment operating log.

2. List the requirements for chemicals used for boiler water treatment.

708. Identify the chemicals used to treat boiler water and list the requirements for their use.

When boiler water is treated to prevent scale and corrosion, the proper control of chemicals is the most important factor. Unless all treatment chemicals are controlled within specified limits, the treatment will be ineffective and the steam may be contaminated. The chemical limits specified below protect the boiler metal against scale and corrosion under average conditions; they are patterned after those used by industry for similar purposes. Under unusual conditions, deviations from standard limits will be necessary. In these cases, all factors involved must be studied to determine the proper chemical concentration limits. Though the following requirements may have been mentioned earlier in the text, this summary should denote their importance.

Chemical Requirements. The requirement for causticity concentration is 20 to 200 ppm, expressed as OH. Caustic soda is added to the boiler water to maintain the causticity of the boiler water within these limits at all times. However, when the water supplied to a plant is high in natural sodium bicarbonate, or when water is sodium-zeolite treated, caustic soda is not always needed. For soluble phosphate concentration of boiler water, the limit is 30 to 60 ppm phosphate, expressed as PO_4 . Sodium metaphosphate is added to keep the boiler water within these limits at all times. The limit for quebracho tannin concentration in boiler water is a medium brown color, as shown by the middle standard of the Bureau of Mines tannin comparator—color No. 3/M. Finally, the specified limit for boiler water dissolved-solid content is 1000 to 4000 ppm. Boilers are blown down sufficiently to maintain these limits at all times. Excessive blowdown, however, should not be practiced.

Exercises (708):

1. Identify the chemicals that are used to treat boiler water.

5-4. Chemical Feeding

Several methods are used to admit water treatment chemicals into the boiler. The method of admission used depends on the design of the boiler plant and the chemical requirements of the boiler water. We discuss these methods in this section. Also, we discuss protective equipment and the chemical storage area.

709. Identify the types of protective equipment and specify the use of proper personnel protective equipment.

Certain activities, particularly those involving specialized industrial processes, may present hazards that are difficult to completely eliminate or adequately safeguard. The best defense against personnel injuries is to keep hazards potential instead of actual. When all practical measures have been exhausted and potential hazards still exist, it is essential that workmen be given further protection through the use of personal protective equipment and clothing. Personal protective equipment and safety devices of various types of design are available to provide safeguards against most of the hazards present when working with chemicals used in water treatment. Some common items of protective equipment and clothing are safety toe shoes, respiratory equipment, goggles, gloves, and rubber aprons.

Safety-Toe Shoes. Safety-toe shoes are worn to protect workers' feet from injuries caused by heavy rolling or falling objects, such as cylindrical chemical containers. These shoes have a steel toe box built into the shoe to provide this protection. All safety-toe shoes used in the Air Force must meet the requirements of appropriate Federal specifications or equal. Under a compression static load of 250 pounds, the minimum clearance between the lowest point of the front edge of the toe arch and the top of the insole will not be less than one-half inch. Under an impact load of 50 pounds dropped from a height of 18 inches, the toe box will not yield below this minimum clearance. Because of the steel box design, safety-toe shoes weigh approximately 1 ounce more than regular shoes. When properly fitted, they do not cause discomfort.



Figure 5-9. Chemical cartridge respirator.

Respiratory Equipment. Breathing equipment of the filter pad, canister, or cartridge type is designed to reduce contaminated air to a safe level for breathing over a short period of time. The chemical cartridge respirator provides protection against certain specified vapors. It also protects against low concentrations of organic vapors, which can be breathed for short periods of time without protection, but which produce injury after continued or prolonged exposure. This respirator is made up of a rubber facepiece and head harness (see fig. 5-9), two threaded metal or plastic cap connections for attaching a filter cartridge at

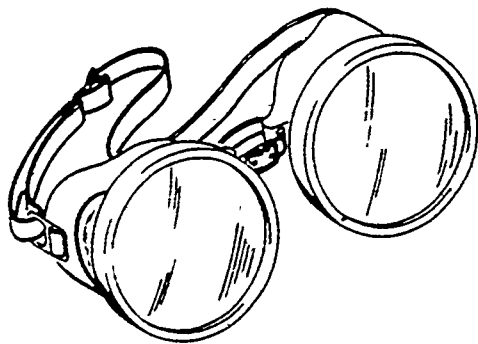


Figure 5-10. Chemical goggles.



Figure 5-11. Rubber acid gloves.

each side, and two filter cartridges. The facepiece is fitted with an automatic exhalation valve. The life of the cartridge used depends upon the concentration of the vapors it is required to filter. When undue resistance to breathing is noticed or when odors of gases or vapors can be detected by the wearer, the cartridge must be replaced. Cartridge respirators are usually approved for protection against concentrations not exceeding 1000 parts per million of organic vapor to air.

Goggles. Almost all eye injuries can be prevented by using suitable safety goggles. This equipment is available to all Air Force personnel who need it in their daily operations. The exact nature of the protection needed must be determined so suitable goggles can be selected that give the wearer the desired protection. The goggles made for working with water treatment are classed as chemical goggles. They are used to protect the eyes against hazards involved in chemical handling operations. The eyecups are ventilated. Baffle plates are fitted within the eyecups to protect the eyes from splashed chemicals that might penetrate the ventilation holes (see fig. 5-10).

Gloves. Numerous jobs require that adequate protective devices be worn by workmen to guard their arms and hands against painful injuries. Various types of gloves and arm protectors are in common use throughout the Air Force. Rubber protective gloves must be worn by personnel whenever acids, alkalies, organic solvents, and other harmful chemicals are used. Gloves will be tested regularly for leaks and other defects. These gloves are usually available in three grades: alkali and acid resistant; general



TO-112A



TO-112B

Figure 5-12. Synthetic coated gloves.

purpose; and organic solvent resistant (see fig. 5-11).

Cotton fabric gloves, covered with synthetic rubber or plastic, provide protection against ordinary concentrations of acids, alkalis, and salt solutions, and may be used for handling wet materials. Because they absorb perspiration, these gloves are much more comfortable to work with than natural rubber gloves (see fig. 5-12).

Rubber Aprons. An item of protective clothing that is designed to protect the bodies of workmen from the hazards normally associated with water treatment is the acid apron. Natural or synthetic rubber or acid-resisting rubberized cloth aprons are worn by personnel handling irritating or corrosive substances, such as the chemicals used to treat boiler water. Aprons normally are worn with acid sleeves and gloves for greater body protection against harmful burns and skin injuries.

Exercises (709):

1. Identify some of the common items of protective equipment and clothing used when working with water treatment chemicals.
2. Why are safety-toe shoes used when working with water treatment chemicals?
3. How is respiratory protective equipment used when treating water with chemicals?
4. Specify the use of chemical goggles.
5. Specify the use of rubber gloves and rubber acid aprons when treating boiler water.

710. Cite the requirements for a chemical storage area.

Accidents don't just happen, they are caused. A thorough investigation of almost any accident will reveal that it was caused by an unsafe act or condition. It seems the most

popular explanation as to the cause of an accident is, "I just wasn't thinking." There are numerous guides that pertain to safety. Certain ones lay down good commonsense rules that apply to handling and storage of chemicals. The following information covers some of the requirements that should be observed when working with chemicals.

Handling of Chemicals. It is your responsibility to use the protective equipment and clothing that are available. Insure that you follow instructions on how and when to use this protective equipment. Also, it is desirable to have a deluge shower installed in an area where chemicals are handled regularly. Another common device that can be used to good advantage is the drinking fountain. It provides an emergency method of washing away any chemical coming in contact with the face or eyes. This is not a "do it yourself guide" for treatment of chemical burns. However, a little first aid before you head for the hospital sometimes reduces what could be a major injury to a minor one.

Storage of Chemicals. Chemicals should be properly identified and labeled to show contents immediately upon receipt. Do not depend upon the ability of the issue clerk or the requester to be able to identify these chemicals at a later date. Remember that unlabeled chemicals are an "accident looking for a place to happen." Chemicals, which are generally received in a dry state, must be properly stored to prevent contamination and absorption of water. This can best be accomplished by making sure that containers are secure and stacked off the floor on pallets or dunnage. The stacked chemicals should never be higher than chest level of the personnel using them. This will avert spilling accidents caused by having to reach above this level to obtain chemicals. Chemicals in metal containers that are to be stored for long periods of time should have the exterior surfaces thoroughly cleaned prior to storing.

Exercises (710):

1. If an accident is thoroughly investigated, what is normally revealed as the cause?
2. In an emergency, how can you wash off chemicals that contact the face or eyes if a deluge shower is not available?
3. What are the requirements for a chemical storage area?

711. Describe the methods and procedures for mixing chemicals.

The methods of mixing chemicals may vary greatly with various installations. However, there are some general rules that should be used. The chemicals should not be mixed in advance of the immediate requirements. Mixing the chemicals too long before they are to be used may result in deterioration, which complicates control of the individual chemicals in the boiler water. Wear protective clothing when mixing chemicals. The mixing should be done at floor level to prevent injury to your eyes and face. Also, never add the water to the chemicals, instead, add the chemicals to the water. Some procedures for mixing chemicals are presented in the following paragraphs.

Mixing Sodium Sulfite. Mix a sodium sulfite solution in cold water just before it is to be used. If it is mixed and exposed to the air for a long length of time, the chemical becomes useless for boiler water treatment. This is caused by air from the surrounding area combining with the sodium sulfite and neutralizing it.

Mixing Caustic Soda. The first step in mixing caustic soda is to dissolve the chemical in water, preferably condensate, although ordinary raw water can be used. When only a few pounds of chemical are involved, a bucket makes a suitable mixing container. Do not heat the water. Add the caustic soda, a little at a time, to the water in the bucket. Stir the solution continuously until all the chemical is dissolved, since it will tend to mat at the bottom of the bucket. Avoid physical contact with the caustic soda solution and be careful not to splatter the solution.

Mixing Phosphate. For the purpose of this discussion, sodium metaphosphate is considered a typical phosphate treatment. Ordinary city water can be used to dissolve sodium metaphosphate. However, if available, a soft water such as treated makeup or return water is preferable. Water should be about room temperature, or a little higher, but not hot. If a bucket is used, the mixture must be stirred until all the chemical is dissolved so that it does not mat at the bottom. Flake-form metaphosphate dissolves easily in open feeders and dissolving tanks when placed in a fine mesh wire basket and suspended just beneath the surface of the water, as shown in figure 5-13. Sometimes a small steam jet is placed in the bottom of the dissolving vessel to facilitate chemical mixture; when it is, special care is required. The sodium metaphosphate solution in the tank may be



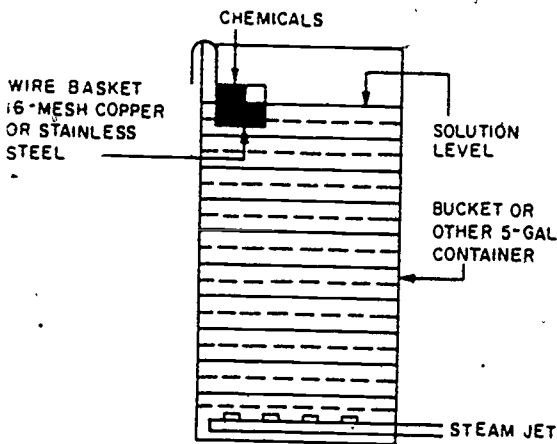


Figure 5-13. Apparatus for dissolving phosphate and tannin.

slightly acid and can corrode the feeder tank. Dissolving a caustic in the tank with the sodium metaphosphate alkalinizes the water and prevents corrosion. If caustic soda is being used for water treatment, it can be dissolved and fed with the metaphosphate. If it is not, add about a quarter of a pound of caustic soda for every 10 pounds of metaphosphate solution in the tank.

Mixing Tannin. Tannin dissolves slowly, particularly in cold water, and it may mat at the bottom of the dissolving container. Therefore, when tannin is dissolved in a bucket, continuous stirring is necessary. The dissolving process can be hastened by breaking the tannin into small pieces and using hot water. When caustic soda is used, the tannin will dissolve more readily if placed in the same solution. Tannin solutions are acid, therefore, dissolving some caustic soda with it to protect the dissolving tank from corrosion is desirable. If an open feeder is used, the tannin can be dissolved by suspending it on a screen or in a basket or perforated bucket just beneath the surface of the water, as explained and shown under mixing phosphate. A fine-mesh screen may be necessary to prevent the tannin from falling through to the bottom of the tank. The tannin can be broken up and suspended in the tank in a porous bag, or, if necessary, it can be dissolved separately in a bucket before it is transferred to an open feeder. Chemical feed equipment is discussed next.

Exercises (711):

1. Describe the procedure for mixing caustic soda.

2. What are the methods for mixing phosphate? Describe them.

3. What methods are used to mix tannin? Describe them.

712. List the methods of feeding chemicals to a boiler.

After chemicals to be used for water treatment are dissolved in water, the next step is to get the solution into the boiler water. The two principal feeding methods are continuous and slug feed.

Continuous Feeding. In continuous feeding, the solution is fed into the feedwater line so that the chemical is added continuously and in proportion to the amount of water flowing through the line. This type of feeding permits maintenance of an equal concentration of chemicals throughout the water being treated. This

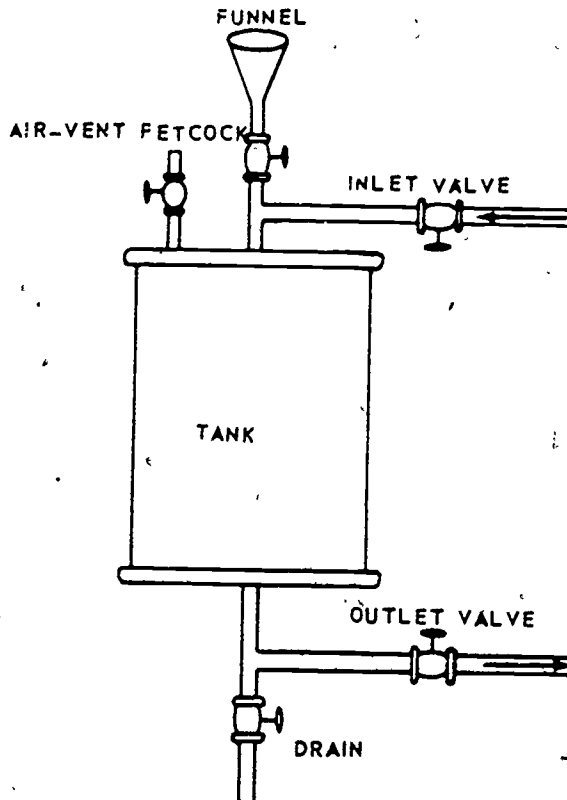


Figure 5-14. Closed feeder.

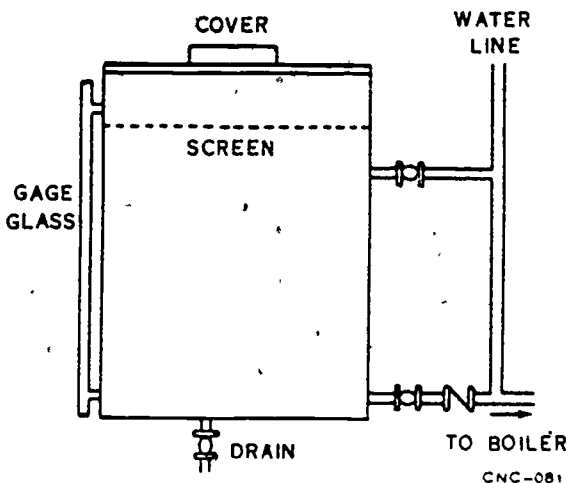


Figure 5-15. Open feeder.

drilled, and tapped. It is large enough to hold the solution of chemical to be used each day or each feeding. It has a funnel attachment for charging, a drain, an air vent, and inlet and outlet valves, as shown. Its capacity is based on the maximum concentration of a pound of chemical per gallon of solution. For many installations, a feeder of convenient size can be made from 6- to 8-inch pipe, cut 2 to 3 feet long. Suppliers of ready-made feeders are listed in various catalogs. Some chemical supply companies also sell ready-made feeders.

Open Feeder. For larger chemical dosages (more than about 10 pounds), it is more convenient to use an open feeder, such as that shown in figure 5-15. The chemical dissolving tank is large enough to hold 1 gallon of solution for each pound of chemical used

method is applicable when feedwater is being treated to raise its pH.

Slug Feeding. In slug feeding, portions of the chemical solution are injected into the feedwater line in the form of shots at specified intervals—once an hour, once a shift, or after a certain quantity of water has flowed through the line. In this way, the chemical is quickly washed through the line after each slug is fed, leaving the line free of chemicals between slugs.

Exercises (712):

1. Which method of feeding chemicals to a boiler is preferable for water being treated to raise its pH?
2. Cite the methods of feeding chemicals to a boiler.

713. Describe chemical feeding equipment and specify the use of the equipment.

It is generally best to use commercial feeders to feed chemicals and adjust dosage. Two principal types are described here: the closed feeder and the open feeder. The closed feeder is used for small chemical dosages, and the open feeder is used for larger dosages.

Closed Feeder. Figure 5-14 shows a simple closed feeder. The tank is either welded or made from a piece of pipe that is capped,

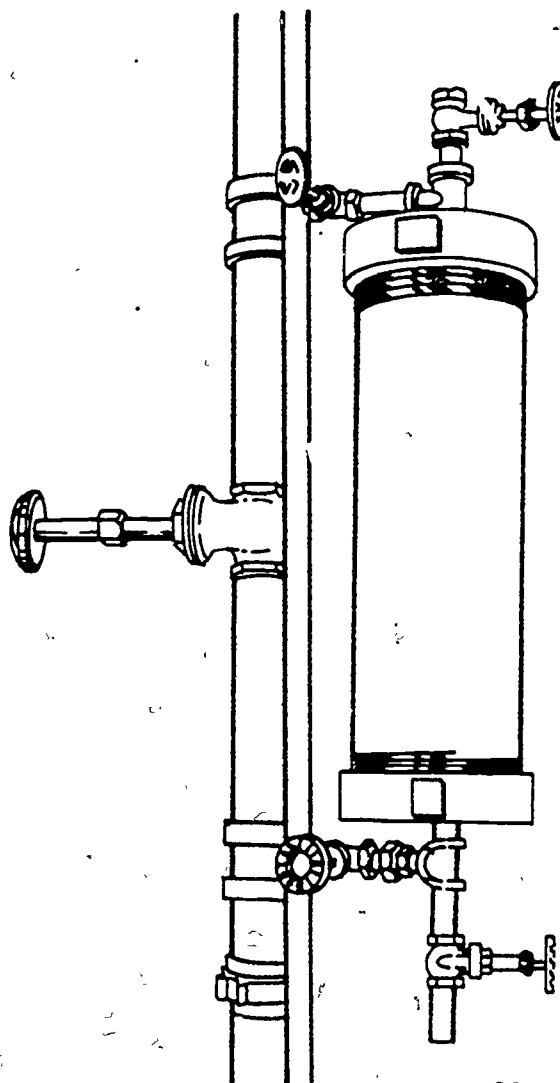
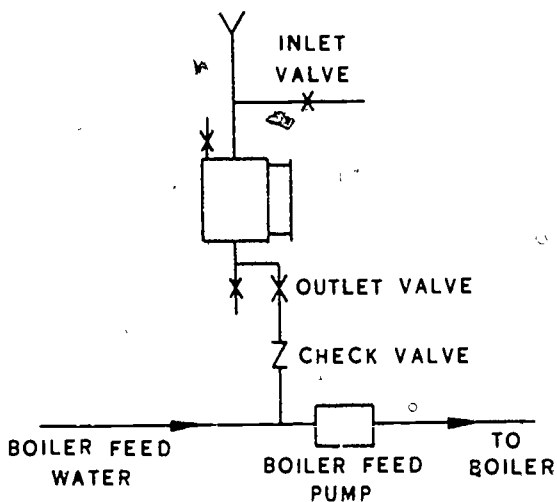


Figure 5-16. Typical bypass-type chemical feeder

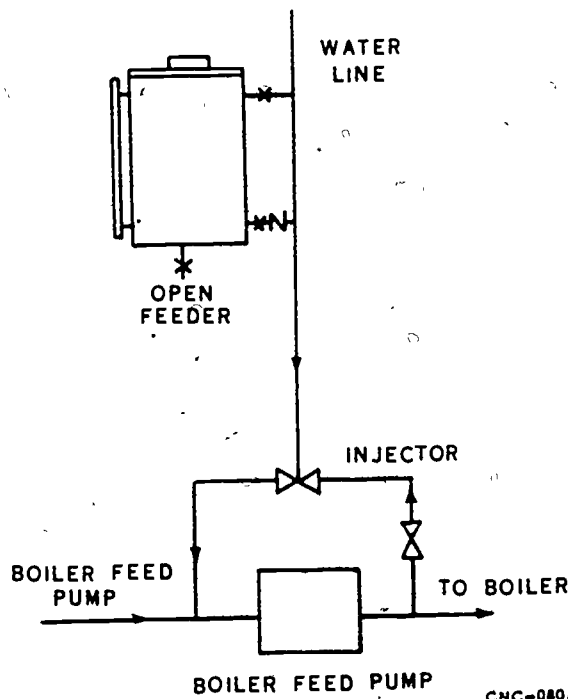
each day. For many installations, a suitable tank can be made from an ordinary 50-gallon steel barrel, such as is used to store oil or alcohol. Do not use tanks made of galvanized or tinned iron or aluminum. Some engineers adapt the open feeder tank from sheet metal. The tank has a valved line near the bottom to carry the chemical solution to the boiler, a gage glass, a cover, and a screen supported at a point about a foot below the top of the tank. The tank is filled and the feedline flushed by a valved waterline (condensate if possible) connected to the tank and the chemical feedline to the boiler, as shown in the illustration. Other water, such as city, softened, or hot, can be piped to the tank, if desired. No direct connection between a potable water supply and the chemical tank is permitted. The screen is needed, since some boiler water chemicals dissolve best when near the surface of the water. A wire basket or perforated bucket suspended at the top of the tank can be substituted for the screen. The check valve shown prevents water from the boiler line from backing up in the chemical tank.

Closed Feeder Installation and Use. To use the closed feeder, valve off the feeder and open the vent, then drain the feeder. Completely fill the feeder with the chemical solution, adding water if necessary, to avoid putting air into the boiler. When the inlet and outlet valves are opened, the chemical solution is fed to the boiler. A sufficient flow of water through the feeder can virtually slug feed the chemical solution into the boiler.



CGK-020

Figure 5-17. Closed feeder at suction side of boiler feed pump.



CNC-080

Figure 5-18. Open feeder for feeding at suction side of boiler feed pump by injector.

Installation in makeup line. The closed feeder can be installed directly in the makeup waterline of boilers, such as low-pressure ones, which use little makeup water. The waterline is opened and connected to the feeder inlet, and the feeder outlet line is connected with the line to the boiler.

Installation on bypass on feedline. When larger amounts of condensate and makeup water is to be fed by a pump, the feeder can be installed on the feedline (as shown in fig. 5-16) either before the boiler feed pump or on the high pressure side of the pump. The chemical is slug fed. On the high pressure side, installing the feeder around the feedwater regulator will divert the concentrated chemical solution from the regulator; thereby eliminating the possibility of chemical action on the valve. Chemicals can be kept from the boiler feedline by connecting the feeder so that the effluent empties directly into the boiler or the feedline close to the boiler.

Installation direct to suction side of boiler feed pump. The closed feeder can be installed to feed into the suction side of the boiler feed pump, as shown in figure 5-17. A check valve prevents feedwater from backing up into the feeder. If there is no positive pressure on the suction side of the feed pump, with the inlet valve open to the atmosphere, the chemical can be fed by gravity. A level glass installed

on the feeder will show the feeding rate. This setup is recommended only for slug feeding. Frequently, there is positive pressure on the suction side of the boiler feed pump. Then pressure can be used at the feeder inlet to force the chemical solution into the boiler feed pump. However, the chemical must be fed rapidly, since raw water is admitted to the boiler simultaneously. Pressure from the boiler feed pump itself can be used if a line is brought from the high pressure side of the boiler feed pump to the closed feeder inlet. The chemical is slug fed by proper adjustment of the valves. Chemicals can be fed by pump rather than pressure. The chemical pump can be small and simply built, since only a small amount of chemical solution is handled and the pressure of the suction side of the boiler feed pump is low. With a high-pressure pump, the chemical can be pumped into the high pressure side of the feed pump or directly into the boiler.

Open Feeder Installation and Use. The line that carries the chemical solution from the open feeder to the boiler is usually connected to feed into the suction side of the boiler feed pump. If there is no pressure at this point, the chemical can be fed continuously or intermittently (slug) by gravity. The level glass shows how much chemical is being fed. If the chemical is slug fed, the solution in the line from the feeder to the pump could gradually flow into the feedlines between slugs. To avoid this, after feeding, flush the line from the tank to the pump with water. If there is pressure at the suction side of the feed pump, overcome it by elevating the feeder, pumping the chemical into the boiler feed pump, or using an injector as shown in figure 5-18. A high-pressure chemical pump

can be used to feed the chemical into the feedline beyond the boiler feed pump or directly into the boiler drum. In special cases, this may be necessary to avoid chemical action in the feedlines. For closely controlled, continuous feeding, the chemical feed can be proportioned to the flow of feedwater by connecting either the chemical pump or the chemical feed pump so that it is actuated by the boiler feed pump. The same effect can be obtained by connecting the chemical feed pump so that it is controlled by operation of a meter on the makeup line.

Exercises (713):

1. Describe a closed feeder that is used to feed chemicals into a boiler.
2. Describe an open feeder that is used to feed chemicals into a boiler.
3. Specify the use of a closed feeder installed on the bypass on the feedline.
4. Specify the use of the check valve when the installation is direct to the suction side of the boiler feed pump.
5. How is the use of the open feeder different from the use of the closed feeder?

ANSWERS FOR EXERCISES

CHAPTER 1

Reference:

- 600 - 1. The heated water is pressurized above the boiling point. Pressure/temperature relationship will always remain in a constant ratio.
- 600 - 2. 134.63 psia.
- 600 - 3. 350° F. and above.
- 600 - 4. HTW is approximately 30 times as efficient as steam.
- 600 - 5. Generators, expansion drum(s), system circulating pump(s), distribution piping, and heat consuming equipment.
- 601 - 1. Water tube boilers.
- 601 - 2. Using old steam drum for expansion tank; and externally mounted expansion tank with specially designed baffles.
- 601 - 3. Baffles allow water to enter the expansion drum but prevent the velocity of the water in the system from interfering with the natural circulation in the boiler.
- 601 - 4. Direct contact heater.
- 601 - 5. A cascade heater consists of perforated spray pipes, tray stacks, perforated plate, and the heater shell or housing.
- 602 - 1. Continuous upward flow generator, counterflow economizer generator, and upward flow economizer generator.
- 602 - 2. Extinguish fires immediately.
- 603 - 1. Forced flow generators rely on a pump for circulation, and a natural circulation boiler relies on the difference in the weight of hot and relatively cooler water.
- 604 - 1. Saturated steam cushion composed of steam and water; and inert gas cushion composed of nitrogen gas and water.
- 604 - 2. (1) Saturated steam cushion flashes a portion of the HTW to steam. HTW flows through the drum, pushing on the steam cushion, which in turn pushes back.
(2) Inert gas cushion uses nitrogen gas to pressurize the system. It may be a variable or fixed gas cushion. The fixed gas cushion has full HTW flow, while the variable gas cushion is installed on a balance line and has no flow.
- 605 - 1. The firing rate of the generator controls the expansion drum pressure of the steam cushion.
- 605 - 2. The pressure regulator and the relief valve on the variable gas cushion control the expansion drum pressure. The fixed gas cushion is controlled the same as the steam cushion.
- 606 - 1. Single stage, constant or variable speed, low head, centrifugal force pumps, can be combined or separate pumping systems, using the system pump as a generator circulating pump or using a separate pump for the generator.
- 606 - 2. One.
- 607 - 1. An automatic valve is designed to bypass the HTW distribution system and route the circulating pump discharge water into the generator inlet.
- 608 - 1. A perforated tube is inserted into the connection tube tank of a generator, which removes soot by blowing air over the heating surfaces.
- 608 - 2. The fires could be extinguished.
- 608 - 3. An abnormal rise in flue gas temperature.
- 609 - 1. A specially designed connection blends cooler return HTW with supply HTW to prevent the supply water from flashing in the circulating pump suction.
- 609 - 2. Preventing flashing, and balancing the zone supply water temperature.
- 610 - 1. a. Differential pressure control: Secures generator fire if the pressure differential between the generator inlet and outlet increases or decreases above or below set limits.
b. Minimum flow Control: Normally, integrated with the flowmeter and secures the generator fires in the event of low flow entering the generator. It will also send the signal to the bypass valve.
c. Thermocouple control: Thermal electric pyrometer which secures the generator fires in the event excessive temperatures are detected in three designated boiler tubes.
d. Expansion drum water level control: Secures the generator fires when abnormal water levels are detected.
f. Flame failure control: Secures the generator fires when the flame sensing device fails to see the flame.
g. Airflow switch: Prevents initial light-off

- and/or secures the fires when the generator is in operation when there is insufficient draft to support combustion.
- h. High-limit pressure control: Secures the generator fires when a preset high pressure is reached.
- 611 - 1. Flue gas recorders and Btu meters.
- 611 - 2. Btu meters record the supply and return water temperatures, the pounds of water circulated, and the Btus. By subtracting the supply water temperatures from the return water temperatures, and multiplying the pounds of water circulated, the Btus per hour are determined.
- 612 - 1. Check completion and proper operation of all of the following:
 - a. Installation, repair, and cleanup work.
 - b. Air and gas passages are tight and free from obstructions.
 - c. All dampers.
 - d. Leaks repaired.
 - e. Insulation.
 - f. All auxiliary equipment.
 - g. All handholes, manholes, and observation doors closed.
 - h. Hydrostatic test performed.
 - i. Nitrogen gas available, if needed.
- 612 - 2. Check the following items or operations:
 - a. Proper water level in the expansion drum.
 - b. Open inlet and outlet valves of the generator, expansion drum, and system.
 - c. Open the inlet valve to the circulating pump, start the pump, and open the discharge valve.
 - d. Check waterflow through the unit.
 - e. Vent air from headers and high points.
 - f. Make final check of limit and safety controls.
- 612 - 3. Proceed as follows:
 - a. Close induced and forced draft dampers.
 - b. Purge for 5 minutes at one-fourth capacity of the unit.
 - c. Light off generator.
 - d. Raise temperature to 212° F. in not less than 90 minutes.
 - e. Increase temperature at a rate of not more than 100° F. per hour.
 - f. Check generator and piping for stresses and strains.
 - g. Observe fires for complete combustion.
 - h. Control firing rate manually until operating temperatures are reached.
 - i. Switch to automatic.
- 613 - 1. Hourly readings and entering results on daily log sheet, checking cooling water, electric motors and bearings, visual inspection, and noise inspection.
- 613 - 2. Monthly High Temperature Water Distribution System Operating Log.
- 613 - 3. Monthly High Temperature Water Plant Operating Log.
- 613 - 4. At least every hour.
- 613 - 5. Open cooling water control valves wider.
- 613 - 6. Leaks, vibration of equipment, stress or strain of piping or equipment, fire and safety hazards, condition of the fires in the generator, smoke exiting the stack.

- 614 - 1. Start at central heating plant and open vent valves on supply and return mains until a steady stream of water flows from the valve. Proceed from plant and bleed the air from the supply and return mains at each manhole or vent point until the end of the mains are reached. Next, open the supply and return HTW valves for each building, and vent the high points of the HTW heat-consuming equipment. Progress through the entire distribution system, one zone at a time, until all air is vented from the system.
- 614 - 2. If air becomes trapped in the system, it can stop the flow of water, or in some cases, cause the HTW to flash to steam.
- 614 - 3. After circulating pumps have been vented and placed in operation, start with the vents on the generator header and proceed to vent any air from the equipment and piping throughout the plant.
- 615 - 1. Direct-return and reversed-return.
- 615 - 2. Pipe sizing, pressure regulating valves, and specially designed orifices.
- 615 - 3. Excessive cost for additional piping and fittings.
- 616 - 1. Type A and type B.
- 616 - 2.
 - a. Class A.
 - b. Class B.
 - c. Class B.
 - d. Class A.
 - e. Class B.
- 617 - 1. Check telltales and drain plugs weekly. Casing leaks are checked by applying an air test of 15 psi to the conduit cavity. The casing should hold this pressure for 15 minutes. If air does not hold, check for leaks with soap solution, or odorized gas.
- 617 - 2. Drain all water from the conduit and turn on the HTW (or steam) to dry the insulation. After the insulation is thoroughly dry, inspect visually to determine leaks.
- 618 - 1. Bellows expansion joint, expansion loop, and ball-type expansion joint.
- 618 - 2. To absorb the lengthwise expansion and contraction of the piping.
- 618 - 3.
 - 1. c.
 - 2. a.
 - 3. b.
- 619 - 1.
 - (1) *Bellows joint.* Check for misalignment, fatigue, corrosion, and erosion. Check the amount of travel between cold and hot conditions. If joint fails, replace the bellows section.
 - (2) *Expansion loops.* Inspect for alignment.
 - (3) *Ball joints.* See that the joint is adequately packed. Adjust or replace gaskets, as required, to prevent leaks and obtain a free working joint.
- 620 - 1. Cast-steel bodies and stainless steel trim.
- 620 - 2. 300 psi.
- 620 - 3. Over 2 inches, outside screw-and-yoke; under 2 inches, screwed bonnets.
- 620 - 4. Under 2 inches, four or five rings; over 2 inches, a minimum of six rings.
- 620 - 5. Back-seating valve.



- 620 - 6. Generator isolation.
- 620 - 7. Bypass line.
- 620 - 8. Welded flanges.
- 621 - 1. a. Daily: Check for leaks and damaged insulation.
- b. Monthly: operate and lubricate zone and branch line control valves; lubricate exposed threads and gearing.
- c. Annually: Inspect and replace packing.

CHAPTER 2

- 622 - 1. To furnish steam to several buildings scattered over a large area.
- 622 - 2. It is used by hospitals for sterilization purposes.
- 622 - 3. To guide the products of combustion through the boiler so the maximum amount of heat is obtained.
- 622 - 4. To increase the capacity.
- 622 - 5. Because the fire and/or combustion gases pass through the tubes.
- 622 - 6. Locomotive, tubular, and Scotch marine.
- 622 - 7. Because they are compact and take up less space.
- 622 - 8. Because the boiler water flows through the tubes and the products of combustion pass around the tubes.
- 622 - 9. The sectional-header cross-drum, box-header cross-drum, and box-header longitudinal-drum boilers all have straight tubes.
- 622 - 10. A water-tube boiler.
- 623 - 1. It is used to indicate the pressure of the steam in the boiler.
- 623 - 2. They are used to prevent live steam from contacting the working parts of the gage; thus they prevent damage to the gage.
- 623 - 3. The steam gage should be marked up to 100 psi because the gage should be capable of reading up to twice the setting of the relief valve.
- 623 - 4. Control the pressure in the boiler, secure the fuel burning equipment when pressure is up, and start the fuel burning equipment when pressure drops.
- 623 - 5. This is to prevent expansion and contraction of the siphon from affecting the accuracy and level of the control.
- 623 - 6. It is a requirement established by the American Society of Mechanical Engineers in their code.
- 623 - 7. Gage glasses are installed on boilers so you can visually determine the level of water in the boiler.
- 623 - 8. Water columns are used to help prevent fluctuation of the water in the gage glass.
- 623 - 9. A safety valve is installed to relieve excessive pressures that may build up in a boiler.
- 623 - 10. Fusible plugs aid in warning the operator when the water gets excessively low in the boiler.
- 623 - 11. A flash tank is used in the disposal of hot water and steam from the boiler blowdown.
- 623 - 12. Steam gage, pressure control, gage glass, water column, safety valve, fusible plug, feedwater control, and the blowdown system.

- 624 - 1. The primary factors are design and design characteristics.
- 624 - 2. The differences in design stem mainly from differences in characteristics of the input to the boiler (the fuel) or the output from the boiler (the steam).
- 624 - 3. Specific installation instructions are furnished by the manufacturer and building plans are furnished by the civil engineer.

- 625 - 1. To determine if there is any interference with rotation.
- 625 - 2. Correct element alignment relative to boiler tubes and the distances of nozzles from the surfaces to be blown.
- 625 - 3. To reduce the starting load.
- 625 - 4. Air preheaters, economizers, superheaters, soot blowers, firing systems, draft fans, combustion controls and meters, feedwater heaters, centrifugal and rotary pumps, reciprocating steam pumps, steam turbines, and boilers.

- 626 - 1. To reduce the starting load on the drive.
- 626 - 2. To remove combustibles.
- 626 - 3. About 6 inches.
- 626 - 4. Place enough coal in the furnace to cover all tuyeres to a depth of about 6 inches; now add shavings or kindling on top of the bed; purge the furnace; light the kindling and regulate the draft to keep the fire going.

- 626 - 5. About 3/4 inches.
- 626 - 6. Purge the furnace, adjust the draft; insert a lighting torch; start the pulverizer and admit coal.
- 626 - 7. Close the burner and pilot valves immediately and purge the furnace before attempting to relight the unit.
- 626 - 8. Purge the furnace; set the draft; vent the gas burner supply header; set the pressure in the burner header and pilot gas header at the correct values for the specific burners and pilots in use; open the pilot gas valve and ignite it with an electric ignitor or a regular torch; open the main gas valve and ignite the main burner gas with the pilot burner.

- 626 - 9. Maintain sufficient firing rate to raise water temperature to the boiling point in about 90 minutes; insure complete combustion; follow standard operating procedures for auxiliary equipment to be placed in service with the boiler; warm up steam header; as the boiler reaches line pressure and begins to steam, the nonreturn valve will open; after the boiler is on the line, close drain valves and the bypass valve around the nonreturn valve; with the auxiliary equipment in service and the boiler steaming, you are now ready for normal operation.

- 627 - 1. It can be injected with the globe valve in the feed pipe to the boiler or automatically with a feedwater regulator.
- 627 - 2. The float and lever or positive displacement type, the thermohydraulic or vapor generator type, and the thermostatic or metal expansion type.

- 628 - 1. To radiate some of the heat and prevent excessive pressures in the closed circuit.

- 628 - 2. Before the generator is started, the regulator valve should be closed, and the generator inner tube should be drained and shut off from the water and steam from boiler. The generator's closed system (outer tube, tubing and diaphragm housing) is filled with hot water. When the generator is operating, with the inner tube open to the boiler drum, the water level in the tube corresponds to the boiler water level. Heat from steam in the upper part of the inner tube raises the temperature of water surrounding this part of the tube and converts some of it to steam. The steam pushes water from the outer tube, through tubing, and into diaphragm housing. Then pressure, acting on the diaphragm, opens the valve against spring force and feeds into boiler. Water in the generator inner tube rises with boiler water level and condenses some of the steam. This reduces heat transfer to outer tube and lowers pressure in the tube. As pressure is reduced, spring forces up diaphragm, water is pushed into generator, and valve closes.
- 628 - 3. When the water level in the boiler drops, more steam is allowed to enter the tube and heat it. More steam causes the thermostat to expand and operate the linkage that opens the valve. This allows more feedwater to be forced into the boiler. As the water level in the boiler rises, less steam is admitted to the tube of the thermostat; consequently, the tube cools and contracts. (The operation of the linkage and bellcrank this time closes the regulating valve.)
- 629 - 1. A feedwater control unit.
- 629 - 2. The feedwater control unit adds water to a boiler by opening a water valve or operating a water pump.
- 630 - 1. Only authorized personnel.
- 630 - 2. Manufacturers will publish specifications.
- 631 - 1. Centrifugal, reciprocating, and rotary.
- 631 - 2. The number of impellers.
- 631 - 3. The high speed of the impeller imparts energy to the liquid and forces it outward.
- 631 - 4. A pump or liquid end, and a drive end.
- 631 - 5. These pumps impart pressure to the liquid with the back-and-forth motion of a piston or plunger.
- 631 - 6. A rotary pump uses rotating cams, screws, lobes, sliding vanes, or gears to impart pressure to the liquid.
- 632 - 1. It is essential that the pump be suited to the hydraulic characteristics of the system and be accurately selected in order to prevent cavitation. Other factors such as vibration, proper pump, speed, motor combination, and liquid temperature must be considered.
- 632 - 2. The low speed pump.
- 632 - 3. In all installations, the pump, driver, and controls must be accessible for repairs; also, piping connections, proper alignment, and proper base connections are considered.
- 633 - 1. Liquid is necessary to lubricate the internal surfaces of the pump.
- 633 - 2. The unit should be at a standstill and at normal operating temperature.
- 633 - 3. The requirements of checking for abnormal noise and vibration or abnormal pressure and flow conditions are common to both pumps. In addition to the normal daily requirements, the reciprocating pump should be checked for abnormal speed, improper stroke length, defective operation of lubricator, ineffective operation of governor, improper action of the air chamber, and steam and water leaks.
- 633 - 4. Abnormal vibration and noise, abnormal pressure and flow conditions, excessive or inadequate packing leakage (water-cooled bearing), hot bearings, and hot stuffing box.
- 633 - 5. On an annual basis, all three types of pumps should be dismantled and checked for discrepancies that may occur to the specific pump. Repair or replace defective parts and correct faulty conditions found during annual maintenance.
- 634 - 1. The Bourdon pressure gage.
- 634 - 2. Indicating-type pressure gage and recording-type pressure gage.
- 635 - 1. The primary problem is that of coordinating the steam pressure with fuel quantity, air for combustion, removal of the products of combustion, and feedwater supply.
- 635 - 2. The "on-off," the positioning, and the modulating or metering.
- 636 - 1. Firing is done at a constant but intermittent rate, in cycles between predetermined high and low pressure or temperature limits of the end product delivered to the system.
- 636 - 2. The operating principle is for the controls to maintain a constant and predetermined fuel-air ratio and steam pressure, water, or air temperature, by positioning mechanical linkages which connect the damper-actuating devices and fuel feed apparatus. With the positioning control, the fuel-air ratio, preadjusted for the best operating conditions expected, remains fixed. In the metering control system, the fuel and airflows are measured and adjusted automatically to provide the best fuel-air ratio at all times.
- 636 - 3. The metering control system.
- 637 - 1. Blowdown is used for discharging sludge and sediment from a boiler. Also, it is used to lower the water level rapidly and to reduce the total concentration of dissolved and suspended impurities in the boiler water.
- 637 - 2. A water column should be blown down once each shift, before placing a boiler on the line, or when in doubt as to the actual water level in the boiler. These blowdowns help remove scale, dirt, or any solid matter that could plug the gage glass connection and cause a false water level indication.
- 637 - 3. Sliding disc, or swing-gate type, seat and disc, or hard seat type; and seatless type.

- 620 - 6. Generator isolation.
- 620 - 7. Bypass line.
- 620 - 8. Welded flanges.
- 621 - 1. a. Daily: Check for leaks and damaged insulation.
- b. Monthly: operate and lubricate zone and branch line control valves; lubricate exposed threads and gearing.
- c. Annually: Inspect and replace packing.

CHAPTER 2

- 622 - 1. To furnish steam to several buildings scattered over a large area.
- 622 - 2. It is used by hospitals for sterilization purposes.
- 622 - 3. To guide the products of combustion through the boiler so the maximum amount of heat is obtained.
- 622 - 4. To increase the capacity.
- 622 - 5. Because the fire and/or combustion gases pass through the tubes.
- 622 - 6. Locomotive, tubular, and Scotch marine.
- 622 - 7. Because they are compact and take up less space.
- 622 - 8. Because the boiler water flows through the tubes and the products of combustion pass around the tubes.
- 622 - 9. The sectional-header cross-drum, box-header cross-drum, and box-header longitudinal-drum boilers all have straight tubes.
- 622 - 10. A water-tube boiler.
- 623 - 1. It is used to indicate the pressure of the steam in the boiler.
- 623 - 2. They are used to prevent live steam from contacting the working parts of the gage; thus they prevent damage to the gage.
- 623 - 3. The steam gage should be marked up to 100 psi because the gage should be capable of reading up to twice the setting of the relief valve.
- 623 - 4. Control the pressure in the boiler, secure the fuel burning equipment when pressure is up, and start the fuel burning equipment when pressure drops.
- 623 - 5. This is to prevent expansion and contraction of the siphon from affecting the accuracy and level of the control.
- 623 - 6. It is a requirement established by the American Society of Mechanical Engineers in their code.
- 623 - 7. Gage glasses are installed on boilers so you can visually determine the level of water in the boiler.
- 623 - 8. Water columns are used to help prevent fluctuation of the water in the gage glass.
- 623 - 9. A safety valve is installed to relieve excessive pressures that may build up in a boiler.
- 623 - 10. Fusible plugs aid in warning the operator when the water gets excessively low in the boiler.
- 623 - 11. A flash tank is used in the disposal of hot water and steam from the boiler blow-down.
- 623 - 12. Steam gage, pressure control, gage glass, water column, safety valve, fusible plug, feedwater control, and the blowdown system.

- 624 - 1. The primary factors are design and design characteristics.
- 624 - 2. The differences in design stem mainly from differences in characteristics of the input to the boiler (the fuel) or the output from the boiler (the steam).
- 624 - 3. Specific installation instructions are furnished by the manufacturer and building plans are furnished by the civil engineer.
- 625 - 1. To determine if there is any interference with rotation.
- 625 - 2. Correct element alignment relative to boiler tubes and the distances of nozzles from the surfaces to be blown.
- 625 - 3. To reduce the starting load.
- 625 - 4. Air preheaters, economizers, superheaters, soot blowers, firing systems, draft fans, combustion controls and meters, feedwater heaters, centrifugal and rotary pumps, reciprocating steam pumps, steam turbines, and boilers.
- 626 - 1. To reduce the starting load on the drive.
- 626 - 2. To remove combustibles.
- 626 - 3. About 6 inches.
- 626 - 4. Place enough coal in the furnace to cover all tuyeres to a depth of about 6 inches; now add shavings or kindling on top of the bed; purge the furnace; light the kindling and regulate the draft to keep the fire going.
- 626 - 5. About 3 1/4 inches.
- 626 - 6. Purge the furnace, adjust the draft; insert a lighting torch; start the pulverizer and admit coal.
- 626 - 7. Close the burner and pilot valves immediately and purge the furnace before attempting to relight the unit.
- 626 - 8. Purge the furnace; set the draft; vent the gas burner supply header; set the pressure in the burner header and pilot gas header at the correct values for the specific burners and pilots in use; open the pilot gas valve and ignite it with an electric ignitor or a regular torch; open the main gas valve and ignite the main burner gas with the pilot burner.
- 626 - 9. Maintain sufficient firing rate to raise water temperature to the boiling point in about 90 minutes; insure complete combustion; follow standard operating procedures for auxiliary equipment to be placed in service with the boiler; warm up steam header; as the boiler reaches line pressure and begins to steam, the nonreturn valve will open; after the boiler is on the line, close drain valves and the bypass valve around the nonreturn valve; with the auxiliary equipment in service and the boiler steaming, you are now ready for normal operation.
- 627 - 1. It can be injected with the globe valve in the feed pipe to the boiler or automatically with a feedwater regulator.
- 627 - 2. The float and lever or positive displacement type, the thermohydraulic or vapor generator type, and the thermostatic or metal expansion type.
- 628 - 1. To radiate some of the heat and prevent excessive pressures in the closed circuit.



- 628 - 2. Before the generator is started, the regulator valve should be closed, and the generator inner tube should be drained and shut off from the water and steam from boiler. The generator's closed system (outer tube, tubing and diaphragm housing) is filled with hot water. When the generator is operating, with the inner tube open to the boiler drum, the water level in the tube corresponds to the boiler water level. Heat from steam in the upper part of the inner tube raises the temperature of water surrounding this part of the tube and converts some of it to steam. The steam pushes water from the outer tube, through tubing, and into diaphragm housing. Then pressure, acting on the diaphragm, opens the valve against spring force and feeds into boiler. Water in the generator inner tube rises with boiler water level and condenses some of the steam. This reduces heat transfer to outer tube and lowers pressure in the tube. As pressure is reduced, spring forces up diaphragm, water is pushed into generator, and valve closes.
- 628 - 3. When the water level in the boiler drops, more steam is allowed to enter the tube and heat it. More steam causes the thermostat to expand and operate the linkage that opens the valve. This allows more feedwater to be forced into the boiler. As the water level in the boiler rises, less steam is admitted to the tube of the thermostat; consequently, the tube cools and contracts. (The operation of the linkage and bellcrank this time closes the regulating valve.)
- 629 - 1. A feedwater control unit.
- 629 - 2. The feedwater control unit adds water to a boiler by opening a water valve or operating a water pump.
- 630 - 1. Only authorized personnel.
- 630 - 2. Manufacturers will publish specifications.
- 631 - 1. Centrifugal, reciprocating, and rotary.
- 631 - 2. The number of impellers.
- 631 - 3. The high speed of the impeller imparts energy to the liquid and forces it outward.
- 631 - 4. A pump or liquid end and a drive end.
- 631 - 5. These pumps impart pressure to the liquid with the back-and-forth motion of a piston or plunger.
- 631 - 6. A rotary pump uses rotating cams, screws, lobes, sliding vanes, or gears to impart pressure to the liquid.
- 632 - 1. It is essential that the pump be suited to the hydraulic characteristics of the system and be accurately selected in order to prevent cavitation. Other factors such as vibration, proper pump, speed, motor combination, and liquid temperature must be considered.
- 632 - 2. The low speed pump.
- 632 - 3. In all installations, the pump, driver, and controls must be accessible for repairs; also, piping connections, proper alignment, and proper base connections are considered.
- 633 - 1. Liquid is necessary to lubricate the internal surfaces of the pump.
- 633 - 2. The unit should be at a standstill and at normal operating temperature.
- 633 - 3. The requirements of checking for abnormal noise and vibration or abnormal pressure and flow conditions are common to both pumps. In addition to the normal daily requirements, the reciprocating pump should be checked for abnormal speed, improper stroke length, defective operation of lubricator, ineffective operation of governor, improper action of the air chamber, and steam and water leaks.
- 633 - 4. Abnormal vibration and noise, abnormal pressure and flow conditions, excessive or inadequate packing leakage (water-cooled bearing), hot bearings, and hot stuffing box.
- 633 - 5. On an annual basis, all three types of pumps should be dismantled and checked for discrepancies that may occur to the specific pump. Repair or replace defective parts and correct faulty conditions found during annual maintenance.
- 634 - 1. The Bourdon pressure gage.
- 634 - 2. Indicating-type pressure gage and recording-type pressure gage.
- 635 - 1. The primary problem is that of coordinating the steam pressure with fuel quantity, air for combustion, removal of the products of combustion, and feedwater supply.
- 635 - 2. The "on-off," the positioning, and the modulating or metering.
- 636 - 1. Firing is done at a constant but intermittent rate, in cycles between predetermined high and low pressure or temperature limits of the end-product delivered to the system.
- 636 - 2. The operating principle is for the controls to maintain a constant and predetermined fuel-air ratio and steam pressure, water, or air temperature, by positioning mechanical linkages which connect the damper-actuating devices and fuel feed apparatus. With the positioning control, the fuel-air ratio, preadjusted for the best operating conditions expected, remains fixed. In the metering control system, the fuel and airflows are measured and adjusted automatically to provide the best fuel-air ratio at all times.
- 636 - 3. The metering control system.
- 637 - 1. Blowdown is used for discharging sludge and sediment from a boiler. Also, it is used to lower the water level rapidly and to reduce the total concentration of dissolved and suspended impurities in the boiler water.
- 637 - 2. A water column should be blown down once each shift, before placing a boiler on the line, or when in doubt as to the actual water level in the boiler. These blowdowns help remove scale, dirt, or any solid matter that could plug the gage glass connection and cause a false water-level indication.
- 637 - 3. Sliding disc, or swing-gate type; seat and disc, or hard seat type; and seatless type.



- 638 - 1. The feedwater going to the boiler continuously carries dissolved mineral matter into the boiler.
- 638 - 2. Bottom blowdown and continuous blowdown.
- 639 - 1. To blow down the boiler, open the valve next to the boiler first; then open the valve farthest from the boiler; blow down the boiler as required; close the valve farthest from the boiler; and last, close the valve next to the boiler.
- 639 - 2. Continuous blowdown can be controlled by hand-operated V-port valves to discharge a definite amount of water, or the amount of blowdown can be set at a definite percentage of the boiler feed.
- 639 - 3. Excessive blowing down of gage glasses roughens the glass.
- 639 - 4. If two drain valves, in series, are provided, open the valve next to the water column first and then open the other valve. Blow down the water column. First, close the valve farthest from the water column and then the valve next to the water column.
- 640 - 1. Steam generating requirements and the importance of the installation.
- 640 - 2. Steam-flow, air-flow meter; U-tube draft gage; and diaphragm-type draft gage.
- 640 - 3. Outlet control damper, inlet vane control, variable speed control, magnetic coupling, hydraulic coupling, and special mechanical drives.
- 641 - 1. All installation, repair, and cleanup work is completed; fan and drive properly lubricated; steam and exhaust lines warmed up and drained of condensate; rotation checked; bearing cooling water supply at correct pressure and temperature; dampers almost closed to reduce starting load; and fan turned by hand to check for rubbing or binding.
- 641 - 2. During the operational check, regulate bearing cooling water flow for proper bearing temperature. Also, observe and record all readings taken from fan thermometers, pressure gages, and draft gages.
- 642 - 1. Pressure gages may be calibrated in pounds per square inch, feet of water, inches of water, or inches of mercury according to the pressure and fluid type.
- 642 - 2. Flowmeters are instruments used to measure the rate of fluid flow.
- 642 - 3. Expansion of a liquid through the tube is directly proportional to the intensity of heat.
- 642 - 4. Level controls are used to maintain a substantially constant level of fluid in a tank, boiler, or other vessel.
- 642 - 5. Changes at the temperature bulb produce expansion or contraction of the medium that fills the system, which in turn causes expansion or contraction of the bellows to actuate the valve and move the valve stem.
- 642 - 6. Pressure controls are used to maintain a substantially constant pressure in one part of the system, while the other part fluctuates or changes its pressure within the range limits; and to maintain a definite difference

- in pressure between two points and control the flow of a fluid.
- 642 - 7. a. *Flow meters:* Inspect for leaks in piping or meter; corroded or eroded, worn out, or otherwise defective parts; plugged internal passages; clogged pipes, tubing, or connections, loose connections; defective gaskets, diaphragms, or bellows; dirt or foreign material; short circuits, open circuits, defective transformers, grounds, or defective insulation in electric-type meters; defective operation of clockwork mechanism or electric motor; binding of moving parts; incorrect meter calibration; and mercury contamination.
 - b. *Level controls:* Be sure to keep the stuffing box leaktight when the system is operating. Also, periodically blow down independent float boxes and check operation of the float and lever mechanisms.
 - c. *Temperature controls:* Blow down strainers and clean the baskets at regular intervals or whenever necessary, observe operation of the control for proper functioning, and check for leaks. Stop stuffing box leaks as soon as possible.
- 643 - 1. Logs provide a means of recording continuous operating data that can affect the operation of all central steamplants.
- 643 - 2. Information compiled and computed on the daily log.
- 643 - 3. The maintenance of an operating log will be in accordance with the manning requirements by plant size.
- 644 - 1. On the reverse side of the respective log.
- 644 - 2. Usually every hour; however, whenever something noteworthy happens, it should be noted in the Remarks section.
- 644 - 3. In pounds for coal, thousands of cubic feet for gas (MCF), and gallons for oil.
- 644 - 4. Draft readings are taken at three locations and are expressed in inches of water.
- 644 - 5. Enter a note in the Remarks section.
- 644 - 6. This temperature is used in computing degree days.
- 644 - 7. Overall efficiency is 79.9 percent.
- 644 - 8. 11.1 percent.
- 644 - 9. By multiplying the total units of fuel by the calorific value and dividing by 1,000,000.
- 644 - 10. By dividing the monthly output by the monthly input and multiplying by 100.
- 645 - 1. AF Form 1163, Monthly High Temperature Water Distribution System Operating Log; and AF Form 1165, Monthly High Temperature Water Plant Operating Log.
- 645 - 2. AF Form 1163 is used for recording data pertaining to high temperature water distribution systems, system water conditions, and treatment of the water. Data recorded on a locally designed, daily log will be entered on AF Form 1165 to provide monthly data on the high temperature water plant.

CHAPTER 3

- 646 - 1. Stopping the fuel supply.



- 646 - 2. Normally, a boiler should be cooled slowly.
- 646 - 3. The steam boiler can be allowed to drain when the furnace section is cool enough for entry.
- 646 - 4. To prevent the formation of a vacuum.
- 646 - 5. By opening the blowoff valves.
- 647 - 1. By disconnecting the unions or flanges, the complete water column can be removed from the boiler.
- 647 - 2. Once the gage glass is properly installed, open the top gage valve slightly to allow a small amount of steam to warm the glass. Close the drain valve and then open the bottom valve slightly to allow water to raise to the proper level and become stable, then fully open the bottom valve and then the top valve.
- 647 - 3. Slowly open gage valves to blow out broken pieces.
- 647 - 4. By using the connection ties and special gage valves.
- 648 - 1. You look for signs of scale, oil, corrosion, abnormal wear, and abrasion.
- 648 - 2. Prepare boiler for the inspection. Enter the boiler using a low voltage, protected, properly grounded light. Check pressure parts for discrepancies. Check condition of drum internals, fuel connections, safety valves, drains, and blowdowns, check connections of the water columns, gage glasses, and steam gages, and check tube ends for leakage and corrosion.
- 648 - 3. Simple washing (hose), mechanical and chemical.
- 648 - 4. A boiler should be cleaned whenever a boiler is removed from service.
- 648 - 5. By using one of the various types of cleaners which generally consist of a motor-driven, flexible shaft with a rotor, brush, or expanding cleaner.
- 648 - 6. As the brushes, cutters, etc., revolve, the cleaner is moved through the tubes to dislodge scale and deposits.
- 648 - 7. All acid cleaning has to be supervised by personnel specially trained and qualified in this specialized field.
- 649 - 1. A fusible plug is replaced annually or more often if the plug's metal alloy doesn't appear sound.
- 649 - 2. Remove it and scrape it clean and bright.
- 650 - 1. They are inspected for warpage, distortion, or damage, in general, and leakage.
- 650 - 2. You can use a graphite compound only on the threads of the studs, which prevents seizure of the nut.
- 650 - 3. Insure that the gasket seating surfaces are clean.
- 650 - 4. You should have these pitted surfaces machined or reground.
- 650 - 5. Tighten the nut up handtight, then give it an approximate one-quarter turn. Do not compress the gasket.
- 651 - 1. Safety valves should be tested after a hydrostatic test, when the valve spring has been adjusted, and when a boiler is returned to service under normal conditions.
- 651 - 2. The methods of testing is handlifting the valve and letting it pop back, reseating itself, and by raising the steam pressure to where the valve operates automatically.
- 651 - 3. Safety valves will be replaced when they are deemed defective, or when there is a change in conditions that affects the working pressure, the heat-absorbing surfaces, or the capacity of the fuel-burning equipment, air supply, or draft.
- 652 - 1. Basically, you inspect the conditions of all supports and hangers. Check refractories, baffles, and tubes.
- 652 - 2. The mechanical method is generally recommended which utilizes manual scrapping, probing, and wire brushing as employed in cleaning firesides of a boiler.
- 653 - 1. They are standard firebrick, plastic firebrick, insulating firebrick, insulating block, building brick, baffle mix, plastic chrome ore, and mortar.
- 653 - 2. Generally, standard firebrick, plastic firebrick, and insulating brick.
- 653 - 3. They should withstand temperatures from 2600° F. to 3000° F.
- 654 - 1. A bond.
- 654 - 2. Bricks should be laid for easy access to repair or replacement without weakening the wall. All joints should be staggered so as to prevent any leakage in or out.
- 654 - 3. Caulk expansion joints with asbestos rope or other suitable material.
- 654 - 4. You use a support called a lintel.
- 654 - 5. Inspect bricks for flows, select proper side, dip brick in water and allow excess water to drip off, and then dip one end and side into the mortar. Position the brick and tap gently to squeeze excess mortar out, making as thin a joint as possible. Bead over the joint.
- 654 - 6. Approximately 12 hours.
- 654 - 7. Remove the damaged positions (both bricks and mortar). Clean the hole out at least 4 inches deep, and pound plastic firebrick into the hole with a mallet until the hole is filled.
- 654 - 8. Always insure that proper venting tasks are completed to provide for rapid loss of moisture. Never allow moisture to be trapped within the plastic, as an explosion could occur when heat is provided and change the moisture to steam.
- 655 - 1. Erosion, corrosion, leaks, loose parts, and general damage.
- 655 - 2. The kind of operation, equipment, and fuel used.
- 655 - 3. After severe storms.
- 655 - 4. A megger.
- 655 - 5. Erosion, corrosion, leaks, and general damage.
- 655 - 6. Every 3 months, or more often if required.
- 656 - 1. You should be able to compare results within an accuracy of 1/4 to 1 percent.
- 656 - 2. Adequate pressurized air or oil is used, depending on the method of testing.
- 656 - 3. Insure that the Bourdon-type pressure gage is installed with a siphon.
- 656 - 4. The gage reading is compared to calibrated weights, which are stamped with a specific pressure.



- 657 - 1. The aboveground system and the underground system.
- 657 - 2. The lines are normally directed to provide the shortest route practical, from the central plant to the demand centers, taking into consideration future developments, crawl spaces, etc.
- 657 - 3. The items of equipment normally found in a distribution system are a pressure-reducing station, various valves (gate, globe, check, etc.), expansion joints, and steam traps.
- 658 - 1. The basic inspection tasks are: repair and cleanup work completed, all conduits and passageways tight and secure, all insulation properly applied, and all equipment ready for operation.
- 658 - 2. Leaks in the distribution system.
- 658 - 3. Inspect for corrosion caused by corrosive gases (CO₂ and CO).
- 658 - 4. Previous inspections and checks.
- 659 - 1. Thermostatic, float and thermostatic, upright bucket, inverted bucket, impulse and throttling traps.
- 659 - 2. (a) The thermostatic trap operates by the expansion and contraction of a bellows, which is activated by temperature changes. (b) The float trap is activated when the condensate level rises, which raises the float; thus opening an orifice, releasing the condensate. (c) The impulse trap operates by a flashing action produced by a pressure drop in the hot condensate, which moves a valve by changing the pressure in a control chamber.
- 659 - 3. The impulse trap.
- 659 - 4. The throttling trap.
- 659 - 5. The thermostatic trap.
- 660 - 1. A continuous steam blow would normally be caused by a defective valve, loss of prime, or by foreign matter on the valve seat.
- 660 - 2. A continuous flow indicates too small a trap, too much condensate, or trap inlet pressure too low.
- 660 - 3. Normally, you would dismantle the trap and clean it. Replace any defective parts, using only matched sets of valves and seats.
- 660 - 4. Once a year, unless otherwise required.
- 660 - 5. Throttle valve "B."
- 661 - 1. Repairing minor leaks due to leakage at valve stems (repacking).
- 661 - 2. Grinding, tapping, refacing, and repacking are some of the more common repairs that can be accomplished by heating personnel.
- 661 - 3. Frozen valves, leaking valves, and chattering valves represent discrepancies warranting repair.
- 662 - 1. Lubricate a slip joint every 6 months.
- 662 - 2. Inspect most expansion joints for corrosion, erosion, wear, deposits, and binding.
- 662 - 3. Alignment.
- 662 - 4. Annually.
- 662 - 5. Prevents leakage and insures a free working joint.
- 663 - 1. By the odorization test.
- 663 - 2. With system dry and lines heated, apply air pressure to the conduit cavity until approximately 15 psig is obtained. If this pressure can be maintained for two consecutive hours, the conduits are usually adequate.
- 663 - 3. You check the roof slab, frame and cover, walls, and floor of the manhole for deterioration.
- 663 - 4. Weekly.
- 663 - 5. By dividing the cfm at atmospheric pressure by the area of the ventilated air passages.
- 664 - 1. Powdered insulation, sheet insulation, block insulation, blanket insulation, tube insulation, and roll insulation.
- 664 - 2. Powdered insulation is applied to odd-shaped areas, etc. Sheet is used on ducts, walls, ceilings, and areas that do not require the insulation to be bent. Block is used to cover boilers. Blanket insulation is used on ducts and pipes. Tube is used on pipes, and roll insulation is used on flat areas such as ducts and casings.
- 664 - 3. Preformed insulation is normally installed with some type of cement to hold it together and fill the openings or cracks.
- 664 - 4. The ratio of powdered insulation and water is normally four parts insulation and one part water. It is applied to odd-shaped areas and worked until excess moisture is removed. It is then covered with cheesecloth.
- 664 - 5. Plastic cement is mixed in a tub or large container, with only enough water to make it workable. Usually, it is applied in coats that should be of a thickness of 1/2-inch for one coat and 1/4-inch for each of two coats.
- 664 - 6. Ducts are covered to reduce heat loss.
- 664 - 7. Duct installation is usually held in place by wires, screws, nails, or paste.
- 664 - 8. Sheet insulation, and roll insulation is usually used for ducts.
- 664 - 9. By installing iron guards.
- 665 - 1. To reduce pressure for certain equipment.
- 665 - 2. The main components are pressure reducing valves, relief valves, strainers, auxiliary valves, and pressure gages.
- 665 - 3. A pressure reducing valve is used to reduce steam pressure; the pressure regulating valve maintains this pressure; the relief valve protects the low pressure lines; the strainer traps dirt, rust, scale and ashes, loose foreign material; and the pressure gage is used to supervise the station.
- 665 - 4. Examine valve stem; replace or metalize, if necessary. Change or regrind valve and seat, as required. Repack stuffing box and check condition of bellows or diaphragm in the pressure reducing valve. On the relief valve, inspect and correct any condition such as: damaged seats, defective parts, erosion, corrosion, wear, or deposits of foreign matter. Clean and repair or replace strainer baskets and gaskets, as necessary.
- 666 - 1. The methods of boiler layup are the dry method and wet method.
- 666 - 2. Quicklime in the amount of 2 pounds per 1000 gallons of boiler water and/or silica gel at 10 pounds per 1000 gallons.



- 666 - 3. Clean and dry unit, insert quicklime or silica gel in proper containers. Tightly close up boiler. Inspect the unit monthly.
- 666 - 4. Maintain boiler concentration of 200-450 parts per million (ppm) of caustic soda and 100-200 ppm of sodium sulfite.
- 666 - 5. Clean boiler. Close it up and fill with water until water overflows from vent. Continuously feed chemicals to the boiler; close vent and maintain pressure of 10 to 15 psig. Weekly analyze water concentration.
- 667 - 1. 70° to 100° F.
- 667 - 2. The water level should be just below the middle of the gage glass.
- 667 - 3. At the handholes and manholes from improperly set gaskets.
- 667 - 4. Light off the boiler and raise temperature to the boiling point, allowing pressure to reach approximately 15 psig. Close drum vent. Normally, leaky gasket joints will appear.
- 668 - 1. Types A, B, C, D, and E.
- 668 - 2. Type A is both an internal and external inspection. Type B is both plus an external while boiler is under a hydrostatic test. The C type is an external while boiler is under normal steam or water pressure. Type D is a hydrostatic external inspection, and type E is an internal and external inspection of expansion tanks.
- 668 - 3. Steam boilers that are assembled on the site require a type B inspection before they are placed in service. Boilers assembled by the manufacturer require the type B inspection before initial operation. All steam boilers require a type A semiannually and a type C 6 months later. Boilers having completed a major overhaul require a type B before operation. New high temperature water (HTW) generators require a type B before operation. All other HTW generators require a type A annually and expansion tanks need a type E annually.
- 669 - 1. First, insure the boiler is clean (fire surfaces), gag the safety valve(s), clean water-sides of boiler. Fill the boiler with water 70° F. to 100° F. and apply a pressure of 15 to 20 pounds below working pressure to insure all test equipment is working properly. Provide necessary equipment and parts for use (hand pumps, gaskets, fusible plugs, etc.). Insure nomenclature plate is readily accessible, and replace all gages and controls with plugs if they will not sustain a hydrostatic pressure. Last, provide a qualified boiler operator to assist the boiler inspector throughout the test.
- 670 - 1. You apply a pressure of 1 1/4 times the safety valve setting for a hydrostatic test.
- 670 - 2. Check boiler for signs of strain or deformation and that the boiler will continue to hold pressure (no leaks).
- 670 - 3. If there is an excessive leakage, overhaul the valves and fittings to insure their tightness.
- 670 - 4. Gag the safety valves.
- 671 - 1. A hydrostatic test is required on all high temperature generators, including expansion

- tanks. A type B inspection is required for all new HTW installations, and a type A is required on all others annually. A type E is required on all expansion tanks annually.
- 671 - 2. Each major command submits a schedule on AF Form 288 to the Defense Supply Agency, Defense Contract Administration Services District, in Ohio. This schedule must be submitted by 1 April of each year. It will include the name and location of the base and plant; building number; boiler identification, which includes the trade name, year built, year installed, type of boiler, size; the date of desired inspection; the type of inspection desired; and the name and title of the person to whom the inspector is to report.
- 671 - 3. An AF Form 296 is prepared in duplicate. This is signed by the base civil engineer, and the original is forwarded to the Defense Supply Agency. Within 30 days of the inspection, the contractor will submit five copies of AF Form 1222 to the Defense Supply Agency, describing the physical conditions of the boiler, listing repairs, etc., required or why hydrostatic test was not performed. The Defense Supply Agency will approve payment of tests upon receipt of AF Form 296 and forward five copies of AF Form 1222 to the major commands, where they will transmit three copies of the AF Form 1222 to the base.

CHAPTER 4.

- 672 - 1. Evaporation, precipitation, infiltration, and runoff.
- 672 - 2. Surface water and ground water.
- 672 - 3. Spring water, shallow well water, deep well water, and mine water.
- 673 - 1. Suspended and dissolved.
- 673 - 2. Turbidity, organisms, and algae.
- 673 - 3. Turbidity is suspended matter, of any nature, in a water supply.
- 673 - 4. The characteristics of taste, odor, color, and turbidity exist when algae is present in a concentrated form.
- 673 - 5. Minerals or salts, alkalinity, free mineral acid, carbon dioxide, sulfate, iron, manganese, oil, oxygen, hydrogen sulfide, and ammonia.
- 673 - 6. a. Turbidity; b. carbon dioxide; c. oil; and d. ammonia.
- 674 - 1. Prevent boiler-scale formations and pitting.
- 674 - 2. Treat the boiler with a chemical that will also treat the steam and return lines.
- 675 - 1. Feedwater heaters, blowdown, steam washer, and evaporators.
- 675 - 2. The external chemical treatment will change or adjust the raw water outside of the boiler to produce a different type of feedwater.
- 675 - 3. Internal treatment entails feeding chemicals into the water inside the boiler, through feed lines, to produce a different type of water.
- 676 - 1. Ion-exchange and precipitation methods.



- 676 - 2. Ion-exchange method: zeolite treatment; precipitation method: lime-soda process.
- 677 - 1. Sodium-zeolite, lime-soda, and hydrogen-zeolite.
- 677 - 2. The hardness elements of calcium and magnesium are exchanged for ions of soluble sodium by passing the water over the zeolite.
- 677 - 3. To remove the calcium and magnesium salts from the feedwater to make it soft and less corrosive.
- 677 - 4. The rinse cycle.
- 677 - 5. A mixture of lime and soda ash is added to the water, causing the hardness salts to precipitate.
- 677 - 6. When it is necessary to reduce alkalinity and soften water at the same time.
- 678 - 1. To keep water softener operations at peak efficiency.
- 678 - 2. Insufficient backwash will leave a dirty, packed zeolite with low capacity. To service this condition, you should adjust the backwash and flow control to deliver the flow rate recommended by the manufacturer.
- 678 - 3. Removal of all zeolite and gravel, correction of causes of upset, and replacement according to manufacturer's instructions.
- 679 - 1. To determine its condition. It is inspected for fines, depth, and mud accumulations.
- 679 - 2. Bulk salt storage, reserve zeolite storage, condition of bed, and bed depth.
- 680 - 1. The alkalinity and hardness checks.
- 680 - 2. This is when the unit is completely dismantled, thoroughly cleaned, and damaged or worn parts replaced.
- 680 - 3. The manufacturer's manual.
- 681 - 1. Calcium and/or magnesium salts dissolved in water.
- 681 - 2. It forms a scale on the metal which acts as an insulator and reduces efficiency.
- 682 - 1. Standard soap solution and EDTA.
- 682 - 2. Determine lather factor if it is not stated on the soap bottle label. Pour 30 ml of sample into an 8-ounce bottle and add soap solution one drop at a time (shake after each drop) until a lather is raised that will last 5 minutes. Deduct the lather factor and multiply the remaining drops by 17.1 to determine hardness in parts per million.
- 683 - 1. Feedwater heaters are used to increase the efficiency and economy of the steamplant.
- 683 - 2. To allow oxygen and other noncondensable gases to escape.
- 683 - 3. By the amount of oxygen each removes from the feedwater.
- 683 - 4. Three. Open heaters, deaerating heaters, and deaerators.
- 684 - 1. A preliminary inspection should be performed.
- 684 - 2. When the water temperature in the unit comes to within 2° F. of steam temperature.
- 684 - 3. Prior to operation make a preliminary inspection, follow the established starting-

- up procedures, perform necessary checks during normal operation, and follow established procedures for shutting down.
- 684 - 4. To insure the equipment performs the function for which it was designed.
- 684 - 5. Check for correct operation of relief valve, steam pressure reducing valve, overflow, controls, alarms, and steam pressure and temperature indicators. Also, check for steam and water leaks and utility operation of the oil separator.
- 684 - 6. Repair or replace defective materials and equipment as required from inspection results.

CHAPTER 5

- 685 - 1. Water quality and boiler construction, materials, operating pressure, capacity, and design.
- 685 - 2. When the plant is equipped with individual boilers rated at 100 horsepower or more. Also, if the plant has one 100 horsepower boiler and one or more at less than 100 horsepower.
- 685 - 3. Usually, these boilers are treated with caustic soda in combination with sodium metaphosphate and quebracho tannin.
- 685 - 4. If no scaling or corrosion exists, there is not any chemical treatment. If there are problems, use caustic soda, sodium metaphosphate, and quebracho tannin.
- 685 - 5. There is no provision for removing the sludge formed in the boiler.
- 686 - 1. Caustic soda, phosphates, tannin, and sodium sulfite.
- 686 - 2. Caustic soda will neutralize acid conditions and will provide the water with hydroxides to combine with magnesium salts to form a sludge that will not adhere to the heating surfaces.
- 686 - 3. The phosphate will combine with the calcium and precipitate it as calcium phosphate.
- 686 - 4. It helps to keep boiler sludge fluid, it will absorb some oxygen, and it forms a protective film on steel.
- 686 - 5. Sodium sulfite will combine with oxygen to form sodium sulfate, thereby ridding the water of the corrosive free oxygen.
- 687 - 1. Insure the boiler water being tested represents the water in the operating boiler.
- 687 - 2. Water columns, continuous blowdown lines, and the upper drums.
- 688 - 1. Cooling coils reduce the possibility of water flashing to steam and leaving a high concentration of solids.
- 688 - 2. Atmospherically cooled coil and water cooled coil.
- 689 - 1. Before the regular blowdown and before chemicals are added.
- 689 - 2. Blowdown sampling connections, extend sample line to bottom of bottle, draw sample slowly, allow water to overflow bottle to expel the air, and stopper the bottle.

- 690 - 1. Industrial Water Laboratory, US Bureau of Mines, College Park, Maryland.
- 690 - 2. To correct faulty analytical techniques and to provide a quality check of reagents used for local analysis.
- 691 - 1. Place a label on the bottle to identify the sample.
- 691 - 2. Prepare and submit a sample monthly.
- 691 - 3. Prepare and submit a sample at 3-month intervals.
- 691 - 4. At monthly intervals.
- 691 - 5. Fill out Form BWS 3 and 3A, Data Sheet for High-Pressure Boiler Water Sample, or Form BWS 4 and 4A, Low-Pressure Boiler Water Sample. Place the bottle and the forms in the special shipping container, affix the address label to the container, and send it to the Bureau of Mines.
- 692 - 1. General irritants.
- 692 - 2. Paints, varnishes, cutting oils, petroleum fuels, and strong soaps.
- 692 - 3. Good housekeeping.
- 692 - 4. The following are general precautions:
 - a. Do not permit dilute or strong sulfuric acid to come in contact with the eyes, skin, and clothing.
 - b. When handling acids, always wear goggles, face shields, gloves, and protective clothing.
 - c. If you mix acid with another substance, always add the acid to the substance cautiously and avoid spattering.
 - d. Always observe instructions about entering cleaning tanks, including the exact steps to be taken, and have a competent individual to supervise the operation.
- 693 - 1. Test kits are available for phosphate, causticity, tannin, equipment used with conductivity meter, sodium sulfite, condensate pH, and pH of boiler water by indicator paper.
- 693 - 2. Causticity reagent No. 1, causticity reagent No. 2, decolorizing carbon, comparator molybdate reagent, stannous chloride, phenolphthalein indicator, sulfuric acid 0.5N, potassium chromate indicator, standard silver nitrate reagent, potato or arrowroot starch, thynol, hydrochloric acid 3N, standard iodateiodide reagent, phosphate test solution, condensate pH indicator, conductivity neutralizing solution, conductivity meter test solution, indicator paper (pH 11 to 12), and indicator paper (pH 10 to 12).
- 693 - 3. Sink, shelf, cabinet, distillation or demineralization unit, and items for cleaning and maintaining laboratory equipment.
- 694 - 1. 20 to 40 parts per million.
- 694 - 2. The purpose is to maintain the sodium sulfite concentration by adding or stopping chemical feed.
- 695 - 1. 70° F. or below.
- 695 - 2. The starch solution loses its sensitivity as an indicator.
- 695 - 3. Draw the water sample and prepare the starch solution for the test. Put two 1/2-ml portions of hydrochloric acid 3N in a clean.

marked test tube; add 1/4 ml of starch solution; add water sample to bring the level to the 25-ml mark and stir the mixture with the glass stirring rod; fill the dropper with standard potassium iodate-iodide and add to the mixture in the test tube, one drop at a time, counting the number of drops and stirring after each addition until the mixture turns blue and stirring does not remove the color. Figure the sodium sulfite concentration in the boiler water by multiplying by 5 the total number, less 1, of drops of reagent used. Each drop of reagent, except the last one, indicates 5 parts per million of sodium sulfite in the sample.

- 696 - 1. 20 to 200 parts per million.
- 696 - 2. The purpose is to determine the amount of causticity or free hydroxide concentration.
- 697 - 1. To minimize absorption of CO₂.
- 697 - 2. When testing boiler water that is appreciably colored by organic material, such as tannin, it is desirable to start with a warm sample at about 160° F. The following is a list of procedures for the test:
 - a. Without disturbing any settled sludge in the container, fill two marked test tubes exactly to the first mark with some of the original boiler (25 ml) water.
 - b. Shake thoroughly causticity reagent No. 1.
 - c. Add enough to each of the two marked test tubes to bring the level exactly up to the second, that is the long mark.
 - d. At this point, a precipitate generally forms in the mixture in the two tubes.
 - e. Stir the mixture in the tubes with the stirring rod.
 - f. Stopper them and let them stand until any precipitate formed has settled to the bottom of the tubes.
 - g. This precipitate carries down with it much of the tannin or other colored materials in the mixture. A warm sample will usually shorten the required settling time.
 - h. Without disturbing any precipitate which has settled to the bottom of the two test tubes, pour enough of the solution from the top of each of the two tubes into the third marked tube to bring the level in the third tube up to the second mark, the long mark.
 - i. If the solution in the tube is not pink, add two drops of phenolphthalein indicator; if the solution does not turn pink when the phenolphthalein indicator is added, there is no causticity in the sample. The test is finished.
 - j. If the solution in the tube is pink, it shows the presence of causticity in the boiler water. Continue the testing procedure.
 - k. With the 8-inch dropper, add causticity reagent No. 2 (1/3 hydrochloric acid) to the solution drop by drop. Stir the solution with the stirring rod to neutralize the causticity in the solution; the pink color will disappear. Stop the



521

addition of the reagent as soon as the pink color just fades out.

- l. The amount of reagent used is shown by the marks on the test tube above the long mark.
- m. Five (5) milliliters are required to fill the test tube between two of the marks, and fractional distances between the marks can be estimated.
- n. For example, if only three-fifths the distances between the long mark and the next mark above were filled, then 3 ml of the reagent were used.
- o. If the distance filled was past the first mark above the longer mark plus three-fifths of the distance to the next mark, then $5 + 3$ equals 8 ml of reagent were used.
- p. The number of milliliters of causticity reagent No. 2 used multiplied by 23 gives the causticity in parts per million of hydroxide (OH) in the boiler water sample.
- q. Thus, in the above sample where 3 ml of causticity reagent No. 2 were used, there were 3×23 or 69 ppm of hydroxide in the boiler water sample.
- r. In cases where 8 ml of causticity reagent No. 2 are used, there are 8×23 or 184 ppm.

- a. Without disturbing any settled sludge in the sample, fill a plain test tube to within an inch or two of the top with the boiler water being tested. The boiler water should preferably be cooled slightly.
- b. Fold a filter paper and place it in a funnel without wetting it down. Place the funnel in a square test tube in the comparator and filter the sample from the plain test tube until it is nearly filled.
- c. Remove the square test tube and note the appearance of the filtered boiler water; it should be almost free of suspended solids or sludge; refilter it, using the same funnel and filter paper until it does come out free of solids.
- d. Set the square test tube containing the filtered sample back in the middle slot of the comparator and compare the color of the sample with the five color standards viewing against a source of very bright daylight.
- e. The color standard that most closely matches the color of the filtered sample gives the tannin color of the boiler water.
- f. For ordinary boiler water conditions, the tannin dosage is usually satisfactory if it maintains a medium tannin color in the boiler water; that is, the filtered boiler water matches the No. 3 tannin color standard.

- 698 - 1. 30 to 60 parts per million.
- 698 - 2. The phosphate test is used to determine the amount of soluble phosphate in the boiler water.

- 699 - 1. To remove any organic color existing in the water.

- 699 - 2. The following is a list of procedures for the phosphate test:
 - a. Without disturbing the settled sludge in the sample, transfer a sufficient amount of the sample to fill two test tubes about halfway.
 - b. Add $\frac{1}{4}$ teaspoon of decolorizing carbon and mix.
 - c. Filter enough sample into the comparator mixing tube to bring it up to the first mark.
 - d. Add molybdate reagent to bring the level to the second (15 ml) mark.
 - e. Add fresh dilute stannous chloride up to the 17.5-ml mark and then mix the solution; if there is any phosphate in the sample, the solution in the mixing tube turns blue.
 - f. Place the tube in the opening provided in the comparator block; if the sample color comes between the two standard ranges of 30 to 60 ppm, the boiler water is satisfactory.

- 700 - 1. The tannin should be a No. 3, medium brown color, as shown on the tannin comparator.

- 700 - 2. The tannin test is made to determine the approximate concentration of tannin in the boiler water.

- 701 - 1. The sample should be free of suspended solids or sludge, so it must be filtered.

- 701 - 2. The following list outlines the procedures for testing boiler water for tannin:

- 702 - 1. 1000 to 4000 parts per million.
- 702 - 2. This test is used to determine the concentration of soluble salts in boiler water and as a control to determine the amount and frequency of boiler blowdown.

- 703 - 1. Move the cell up and down several times to release the bubbles which may adhere to the cell.

- 703 - 2. When the dark segment of the electron tube reaches its widest opening and a sharp shadow appears.

- 703 - 3. Multiply the specific conductance reading by the tannin factor.

- 703 - 4. The following is a list of procedures for testing boiler water for dissolved solids:
 - a. Without disturbing settled sludge in sample container, pour 60 ml of it into test tube.
 - b. Add two dropperfuls (filled to the mark) of conductivity-neutralizing solution. Stopper and invert several times to mix.
 - c. Connect the terminals of the dip cell to the appropriate terminals of the conductivity meter.
 - d. Plug the instrument cord into a 105- to 130-volt, 50-60 cycle AC outlet and turn on the control switch.
 - e. Fill a clean 200-mm x 38-mm test tube about halfway with distilled water and clean the cell by moving it up and down several times in the distilled water. Remove the cell and shake it to remove excess distilled water.
 - f. Immerse the cell in the sample being tested to a point where the level of the solution is at least $\frac{1}{4}$ inch above the vent

holes. Move the cell up and down several times, making sure the vent holes remain below the liquid level. This action will release any air bubbles adhering to the inner cell wall.

- g. Set the thermometer in the test sample in the test tube.
- h. After the thermometer reading has stabilized, set the instrument temperature adjustment knob to correspond with the thermometer reading. Remove thermometer and set the cell as near center in the test tube as possible.
- i. After the instrument has warmed up, rotate the control dial of the instrument until the dark segment of the electron tube reaches its widest pattern and a sharp shadow is obtained.
- j. To calculate the results in parts per million (ppm), multiply the reading obtained from the control dial scale by one of the following conversion factors:

Tannin Number	Factor
0	0.7
1	0.8
2,5	0.9
4,5	1.0

Example: If the sample has a tannin number of 1 and a specific conductance of 3100 micromhos/cm, the concentration of the sample is 3100 x 0.8, or 2480 ppm.

- 704 - A volatile gas, carbon dioxide, carries over with steam and dissolves in the condensate to form carbonic acid.
- 704 - 2. Neutralizing amine treatment can be used to partially control corrosion in condensate return lines.
- 705 - 1. Just on the alkaline side (7.0 to 7.5).
- 705 - 2. The neutralizing amines approved for Air Force use are cyclohexylamine and morpholine.
- 706 - 1. Colorimetric method, Bureau of Mines test kit method for boiler water and Bureau of Mines test kit for condensate water.
- 706 - 2. The following information describes two methods of testing pH of water:
 - a. Boiler water pH test procedure. Fill the beaker about three-fourths full with sample. Remove a strip of pH 10 to 12 indicator paper from the vial and dip it into the sample in the beaker, leaving it immersed for 30 seconds. If the color of the paper does not change, or changes to yellow or very light orange, the pH of the sample is too low. If the paper turns orange or red, the pH is either satisfactory or too high. Remove a strip of pH 11 to 12 indicator paper from the vial and dip it into the sample in the beaker, leaving it immersed for 30 seconds. If the color of the paper remains the same, or changes to light blue, the pH is satisfactory. If the paper turns deep blue, the pH is higher than necessary. In most instances, a satisfactory pH indicates a boiler water pH in the range of 10.5 to 11.5.
 - b. Condensate water pH test procedure.

Fill the testing beaker to the 50-ml mark with a freshly drawn sample. The sample need not be cooled, but it should be collected slowly to reduce flashing. With the marked dropper, add 1/2-ml of indicator solution to the sample in the beaker and stir the solution. The resulting color indicates the pH. Green shows an acid condensate; light pink, a neutral or slightly alkaline pH, which is normally satisfactory; red or purple, a higher-than-necessary pH.

- 707 - 1. AF Form 1459, Water Treatment Operating Log for Steam and Hot Water Boilers.
- 707 - 2. Not later than the 20th of the month following the reporting period.
- 707 - 3. The following list explains the procedures for maintaining the water treatment log by identifying the entries required for each column:
 - a. Columns A through C. For steam boilers only. Enter in the appropriate column the parts per million (ppm) of phosphate found by the colorimetric method.
 - b. Column D. Enter the number of milliliters (ml) of causticity reagent No. 2 required to destroy the pink color.
 - c. Columns E through G. Required for steam boilers. Multiply the value entered in column D by 23 to obtain the result in parts per million OH and enter in appropriate column.
 - d. Column H. For steam boilers only. Enter the number for the proper color designation for the filtered sample of boiler water as determined with the color standards. Colors are (1) very light, (2) light, (3) medium, (4) dark, (5) very dark.
 - e. Column I. Enter the reading obtained from the conductivity meter.
 - f. Column J. Enter the dissolved solids in ppm as calculated by multiplying the conductivity reading (column I) by the proper conversion factors.
 - g. Column K. Enter the parts per million sulfite content as determined by the test for sodium sulfite. High temperature water heating systems require 20 to 40 parts per million sodium sulfite. This chemical is not to be used in steam boilers except on approval by major command.
 - h. Column L. For high temperature water systems, i.e., 350° F. water and higher. Enter the pH of the sample tested. Required range is 9.3 to 9.9.
 - i. Columns M through R. Enter the total number of pounds of each chemical added to the boiler or hot water generator during the day. Use the blank columns for chemicals added other than those listed in columns M through P, such as amines.
 - j. Column S. Enter the pH of the condensate return water. If a pH meter is not available, use the Bureau of Mines test kit for condensate pH and enter color reading.
 - k. Column T. Determine the total number of gallons of blowdown water and enter

the amount in this column. Do not blow down high temperature water systems.

- l. *Column U.* Enter the total gallons of makeup water.
 - m. *Column V.* Enter the hardness in ppm of the makeup water.
 - n. *Columns W through AA.* These columns are used for central heating plants that have ion exchangers in conjunction with their operation for sole or partial use of the heating plant. Enter in columns W, X, and Y the quantity of water processed daily in each ion exchanger. Enter in column Z the total quantity in gallons of water processed to the heating plant through all exchangers. Enter in column AA the quantity and type of chemical (salt, acid, or alkali) used to regenerate the ion exchangers.
 - o. *Remarks.* The remarks space may be used to indicate any unusual conditions or to report special data.
- 708 - 1. Caustic soda, phosphate, and tannin.
 - 708 - 2. a. Add enough caustic soda to maintain a causticity concentration of 20 to 200 ppm.
 - b. Add sodium metaphosphate to maintain a phosphate concentration of 30 to 60 ppm.
 - c. Add enough tannin to maintain a number 3/M color.
 - d. Use blowdown to maintain dissolved-solid content within 1000 to 4000 ppm.
 - 709 - 1. Safety-the shoes, respiratory equipment, goggles, gloves, and rubber aprons.
 - 709 - 2. These shoes are used to protect the workers' feet from injuries caused by heavy or rolling objects.
 - 709 - 3. Chemical cartridge respirators, usually approved for protection against concentrations not exceeding 1000 ppm of organic vapor to air, are used to reduce the contaminated air to a safe level for breathing over a short period of time.
 - 709 - 4. Chemical goggles, equipped with eyecups that are ventilated and fitted with baffle plates within the eyecups to prevent ventilation perforation chemical penetration, are used to protect the eyes from splashed chemicals.
 - 709 - 5. Rubber gloves and rubber aprons are items of protective clothing used to protect the hands, arms, and bodies of personnel working with chemicals.
 - 710 - 1. An unsafe act or condition.

- 710 - 2. Use the drinking fountain.
- 710 - 3. Identify and label chemicals immediately, stack them on pallets to keep them dry, and do not stack them higher than chest level of using personnel. Also, clean exterior surfaces of metal chemical containers that are to be stored for long periods.
- 711 - 1. Add caustic soda, a little at a time, to cold water; stir constantly, to avoid a mat of chemical at the bottom, until the chemical is completely dissolved.
- 711 - 2. If a bucket is used, add the chemical to the water and stir until the chemical is completely dissolved. Flake-form metaphosphate can be mixed by placing it on a screen and suspending it just below the mixing tank water surface.
- 711 - 3. If a bucket is used, add tannin to the water and stir constantly until the chemical is dissolved. It can also be placed on a fine-mesh screen or in a basket or perforated bucket and suspended just below the surface of the water in the mixing tank. Another method is to break the tannin up, put it in a porous bag, and suspend it in the tank for dissolving.
- 712 - 1. Continuous feeding method.
- 712 - 2. The two principal feeding methods are continuous and slug feed.
- 713 - 1. The tank is either welded or made from a piece of pipe that is capped, drilled, and tapped, and is large enough to hold the chemical solution to be used each day or each feeding. It has a funnel attachment for charging, a drain, an air vent, and inlet and outlet valves.
- 713 - 2. The tank is large enough to hold 1 gallon of solution for each pound of chemical used each day. The tank has a valved line near the bottom to carry the chemical to the boiler, a gage glass, a cover, and a screen supported at a point about a foot below the top of the tank.
- 713 - 3. It is used when larger amounts of makeup water are used. A tank is installed for receiving condensate, and makeup water is to be fed by a pump. The chemical is slug fed.
- 713 - 4. A check valve prevents feedwater from backing up into the feeder.
- 713 - 5. The closed feeders (with various installations) are all used to slug feed the chemical solution while the open feeder can be used to feed constantly or intermittently.

STOP -

1. MATCH ANSWER SHEET TO THIS EXERCISE NUMBER.

2. USE NUMBER 1 OR NUMBER 2 PENCIL.

54730 04 24

EXTENSION COURSE INSTITUTE
VOLUME REVIEW EXERCISE
CENTRAL HEAT PLANTS

Carefully read the following:

DO'S:

1. Check the "course," "volume," and "form" numbers from the answer sheet address tab against the "VRE answer sheet identification number" in the righthand column of the shipping list. If numbers do not match, take action to return the answer sheet and the shipping list to ECI immediately with a note of explanation.
2. Note that numerical sequence on answer sheet alternates across from column to column.
3. Use a medium sharp #1 or #2 black lead pencil for marking answer sheet.
4. Circle the correct answer in this test booklet. After you are sure of your answers, transfer them to the answer sheet. If you *have* to change an answer on the answer sheet, be sure that the erasure is complete. Use a clean eraser. But try to avoid any erasure on the answer sheet if at all possible.
5. Take action to return entire answer sheet to ECI.
6. Keep Volume Review Exercise booklet for review and reference.
7. If *mandatorily* enrolled student, process questions or comments through your unit trainer or OJT supervisor.
If *voluntarily* enrolled student, send questions or comments to ECI on ECI Form 17.

DON'TS:

1. Don't use answer sheets other than one furnished specifically for each review exercise.
2. Don't mark on the answer sheet except to fill in marking blocks. Double marks or excessive markings which overflow marking blocks will register as errors.
3. Don't fold, spindle, staple, tape, or mutilate the answer sheet.
4. Don't use ink or any marking other than a #1 or #2 black lead pencil.

NOTE: NUMBERED LEARNING OBJECTIVE REFERENCES ARE USED ON THE VOLUME REVIEW EXERCISE. In parenthesis after each item number on the VRE is the *Learning Objective Number* where the answer to that item can be located. When answering the items on the VRE, refer to the *Learning Objectives* indicated by these *Numbers*. The VRE results will be sent to you on a postcard which will list the *actual VRE items you missed*. Go to the VRE booklet and locate the *Learning Objective Numbers* for the items missed. Go to the text and carefully review the areas covered by these references. Review the entire VRE again before you take the closed-book Course Examination.

523

Note to Student. This Volume Review Exercise contains 123 four-option items and 1 three-option item.

Multiple Choice

1. (400) What is the operating range for the high temperature water (HTW) system?

a. 300° F. and below.	c. 300° F. to 350° F.
b. 250° F. to 300° F.	d. 350° F. and above.

2. (601) Return water from an HTW enters a cascade heater

a. through the bottom.	c. under the tray stacks.
b. through the top.	d. through the perforated spray pipes.

3. (602) What action should be taken if a low water-flow condition occurs in a high temperature water (HTW) generator?
 - a. Extinguish the fires immediately.
 - b. Check the firing rate of the generator.
 - c. Blow down the generator.
 - d. Secure the circulating pumps.

4. (603) The type of boiler system that relies on the differences between hot water and cooler water for circulation is the

a. forced circulation.	c. combined pumping.
b. natural circulation.	d. separate pumping.

5. (604) Which of the following systems is not a means of pressurizing an HTW system?

a. Oxygen gas cushion.	c. Variable gas cushion.
b. Fixed gas cushion.	d. Saturated steam cushion.

6. (605) What controls the pressure of a saturated steam cushion expansion drum?

a. The amount of makeup water.	c. The amount of water in circulation.
b. The size of the system pump.	d. The firing rate of the generator.

7. (606) The two types of pumping systems used in an HTW are the
 - a. single stage and double stage.
 - b. variable speed and constant speed.
 - c. combined and separate.
 - d. internal and external.

8. (607) What part of an HTW system does the bypass valve bypass?

a. The generator.	c. The circulating pump.
b. The expansion drum.	d. The distribution system.

9. (608) The purpose of soot blowers is to

a. increase efficiency.	c. decrease efficiency.
b. increase draft.	d. decrease draft.

10. (609) The component in an HTW system that prevents flashing in the circulating pump is the

a. bypass valve.	c. expansion drum.
b. mixing connection.	d. makeup pump.



- 11. (610) Which control operates the bypass valve in an HTW system?
 - a. Differential pressure control.
 - b. Thermocouple control.
 - c. High-limit control.
 - d. Expansion drum water level control.
- 12. (610) In an HTW, which control will prevent the generator from firing because of insufficient draft?
 - a. High-limit control.
 - b. Flame failure control.
 - c. Airflow switch control.
 - d. Minimum flow control.
- 13. (611) What are the two temperature recorders used in HTW systems?
 - a. Flue gas and Btu meters.
 - b. Btu meters and CO₂ meters.
 - c. CO₂ meters and flowmeters.
 - d. Flowmeters and flue gas.
- 14. (612) Newly installed HTW generators are administered a hydrostatic test of
 - a. 1 1/2 times the pressure setting of the safety valve.
 - b. 2 times the pressure setting of the safety valve.
 - c. 2 1/2 times the pressure setting of the safety valve.
 - d. 3 times the pressure setting of the safety valve.
- 15. (613) The HTW plant operator checks the circulating pump cooling water to
 - a. see if the HTW is properly cooled.
 - b. determine the quantity of water used.
 - c. see if the pump is running hot.
 - d. determine the speed of the pump.
- 16. (614) The devices installed throughout HTW systems to eliminate trapped air in the system are air
 - a. locks.
 - b. vents.
 - c. traps.
 - d. tanks.
- 17. (615) Which method of HTW distribution requires pipe sizing or specially designed orifices to balance the distribution of heat?
 - a. Series loop.
 - b. One-pipe radial.
 - c. Reversed-return.
 - d. Direct-return.
- 18. (616) Which class of conduit system should be used when ground water may cover the conduit?
 - a. Class A.
 - b. Class B.
 - c. Class C.
 - d. Class D.
- 19. (617) Leaks are detected in the casing of a class A conduit system by the
 - a. air test.
 - b. gas test.
 - c. water test.
 - d. temperature test.
- 20. (618) Which device is installed in HTW distribution systems to absorb the lengthwise expansion of the piping?
 - a. Expansion joints.
 - b. Construction joints.
 - c. Recoil springs.
 - d. Expansion springs.



21. (619) How often are HTW expansion joints inspected?
- a. Daily.
 - b. Weekly.
 - c. Monthly.
 - d. Annually.
22. (620) What is the minimum rated operating pressure of valves used in HTW systems?
- a. 100 psig.
 - b. 200 psig.
 - c. 300 psig.
 - d. 400 psig.
23. (621) HTW zone control valves should be operated and lubricated
- a. daily.
 - b. weekly.
 - c. monthly.
 - d. annually.
24. (622) Baffles are provided in a boiler to prolong the exit of gases from the furnace to
- a. improve combustion of the fuel burned.
 - b. increase heat adsorption by the water.
 - c. reduce objectionable gases in the exhaust.
 - d. precipitate soot from the exhaust gases
25. (622) The two general types of steam boilers are
- a. fire-tube and water-tube.
 - b. water-tube and vent-tube.
 - c. firebox and locomotive.
 - d. fire-tube and Scotch marine.
26. (623) When a steam boiler has a great deal of vibration during operation, the pressure control is
- a. replaced with temperature controls.
 - b. mounted on a flexible connector.
 - c. installed remotely with suitable piping.
 - d. attached to a pressure regulator.
27. (623) Where should blowdown water from a boiler be piped?
- a. Open holding tank.
 - b. Sanitary sewer.
 - c. Treatment tank.
 - d. Flash tank.
28. (624) A boiler foundation is usually built according to the
- a. manufacturer's plans.
 - b. civil engineer's plans.
 - c. building plan specifications.
 - d. appropriate TD or AFM.
29. (625) During the preoperation check of a boiler, the starting load on a forced draft fan is kept down by
- a. opening dampers fully.
 - b. closing dampers 20 percent.
 - c. closing dampers 80 percent.
 - d. closing dampers fully.
30. (626) What is the minimum time for purging the combustion chamber of a stoker-fed coal-fired boiler before lighting the fire?
- a. 30 seconds.
 - b. 2 minutes.
 - c. 5 minutes.
 - d. 10 minutes.

- 31. (626) The main steam stop valve of a started up boiler will be opened to place the boiler on line when boiler pressure
 - a. exceeds line pressure 15 to 20 psig.
 - b. exceeds line pressure 5 to 10 psig.
 - c. is equal to line pressure.
 - d. is within 10 to 15 psig of line pressure.

- 32. (627) Installed automatic, throttling-type, feedwater regulators are required to have
 - a. inlet stop valves only.
 - b. outlet stop valves only.
 - c. either inlet or outlet stop valves.
 - d. throttling bypass valves for manual control.

- 33. (628) A metal expansion feedwater regulator shuts off the flow of feedwater to the boiler by
 - a. contraction of the metal thermostatic tube.
 - b. expansion of the metal thermostatic tube.
 - c. increasing the pressure in the metallic bellows.
 - d. decreasing the pressure in the metallic bellows.

- 34. (629) The boiler feedwater control unit protects the boiler against low water damage by doing all of the following except
 - a. activating the emergency feedwater system.
 - b. bypassing the feedwater heater.
 - c. stopping operation of the burner.
 - d. activating a low water bell.

- 35. (630) Feedwater units are adjusted in compliance with,

a. Air Force regulations.	c. Air Force manuals.
b. technical orders.	d. manufacturer's specifications.

- 36. (631) The shaft on a centrifugal pump is protected from the abrasive wear of the pumped liquid by

a. deflector vanes.	c. shaft sleeves.
b. wearing rings.	d. shaft seals.

- 37. (632) A new pump being installed in a heating system must
 - a. be bench checked before installation.
 - b. support part of the piping.
 - c. have a reducer in the suction pipe.
 - d. be realigned after installation.

- 38. (633) A centrifugal pump should be inspected for excessive packing leakage

a. daily.	c. monthly.
b. weekly.	d. semiannually.

- 39. (633) Wearing rings in a centrifugal pump are normally replaced when the original clearance has increased

a. 10 percent.	c. 1 1/2 times the original clearance.
b. 25 percent.	d. to twice the original clearance.



- 40. (634) The most common type of pressure gage used on a boiler is one with a
 - a. bimetallic element.
 - b. Bourdon tube.
 - c. vapor pressure unit.
 - d. resistance coil.
- 41. (635) The main control systems for a boiler are the
 - a. on-off system, hydraulic system, and modulating system.
 - b. electric remote control, positioning system, and on-off system.
 - c. on-off system, positioning system, and metering system.
 - d. automatic remote control, hydraulic positioning, and on-off system.
- 42. (636) What boiler control system controls output by maintaining a constant and predetermined fuel-air ratio, steam pressure, water, or air pressure?
 - a. On-off.
 - b. Positioning.
 - c. Metering.
 - d. Modulating.
- 43. (637) A blowdown valve that uses a sliding plunger is a
 - a. swing-gate type.
 - b. globe type.
 - c. seatless type.
 - d. sliding-disc type.
- 44. (637) A boiler that operates at over 100 psig requires each bottom blowdown pipe be equipped with two blowdown valves in series. Which combination is not correct?
 - a. Two quick-opening valves.
 - b. One slow-opening and one quick-opening valve.
 - c. A slow-opening valve and a plug cock.
 - d. Two slow-opening valves.
- 45. (638) A continuous blowdown line on a boiler is usually installed
 - a. at the lowest point in the boiler.
 - b. where the concentration of dissolved solids is highest.
 - c. near the top of the boiler below water level.
 - d. at the point farthest from feedwater entry.
- 46. (639) To keep from being wasteful, the maximum continuous blowdown rate for a boiler is
 - a. 3 percent.
 - b. 5 percent.
 - c. 10 percent.
 - d. 15 percent.
- 47. (639) On a blowdown pipe with two valves, the proper opening and closing sequence of the valves is to open the valve
 - a. next to the boiler first and close it last.
 - b. next to the boiler first and close it first.
 - c. farthest from the boiler first and close it first.
 - d. farthest from the boiler first and close it last.
- 48. (640) A simple U-tube draft gage registers the amount of draft in terms of
 - a. inches of mercury.
 - b. linear feet per minute.
 - c. inches of water.
 - d. cubic feet per minute.

- 49. (641) During an operational check of a draft fan with water-cooled bearings, the bearing temperature is found to be 75° F. Bearings at this temperature
 - a. are operating normally.
 - b. may accumulate condensation.
 - c. may not lubricate properly.
 - d. need cooling water flow increased.

- 50. (642) To increase the temperature setting on a temperature control, it is necessary to
 - a. move the control valve nearer the bellows.
 - b. increase the pressure on the valve stem.
 - c. shift lever weight closer to the fulcrum.
 - d. increase the compression on the spring.

- 51. (643) An operator visits a 1,200,000 Btu/hr, 20 psi steam, stoker-fired plant on the required schedule. The number of entries in the hourly reading blocks on the AF Form 1458 at the end of the day is
 - a. 2.
 - b. 3.
 - c. 6.
 - d. 24.

- 52. (644) The total steam flow produced in a central steam plant during an 8-hour period is determined by
 - a. subtracting the integrator start reading from the final reading.
 - b. subtracting the integrator final reading from the start reading.
 - c. direct reading of the integrator.
 - d. totaling the hourly flow readings.

- 53. (645) The logs kept on high temperature water plant operation and distribution systems are
 - a. AF Forms 1163 and 1458.
 - b. AF Forms 1165 and 1464.
 - c. AF Forms 1464 and 1165.
 - d. AF Forms 1165 and 1163.

- 54. (646) When the fire burns down and the steam in the boiler drops below header pressure, you should
 - a. close the header and feedwater valves.
 - b. open the hand-operated header valves.
 - c. close the drain valves.
 - d. open the nonreturn valves.

- 55. (646) Forced cooling is accomplished by
 - a. circulating water through the boiler.
 - b. circulating air through the setting.
 - c. increasing pressure in the header.
 - d. decreasing vacuum in the drum vent.

- 56. (647) The water glass on the gage is warmed by
 - a. circulating steam through the glass.
 - b. circulating water through the glass.
 - c. increasing the pressure in the glass.
 - d. decreasing the vacuum in the glass.

- 57. (648) The primary purpose of using a chemical cleaner is to
 - a. remove scale and corrosion.
 - b. dislodge caked mud.
 - c. protect the tube surface.
 - d. save time and money.



- 58. (649) What is the maximum length of time that a fusible plug can be used?
 - a. 6 months.
 - b. 1 year.
 - c. 18 months.
 - d. 2 years.

- 59. (650) When handhole and manhole covers are installed, you should
 - a. rough up the seating surface with fine grit paper.
 - b. use the old gasket with new makeup compound.
 - c. apply graphite to the seating surface.
 - d. fit a new gasket to the seating surface.

- 60. (650) When first installing a manhole plate, the stud nut should be tightened
 - a. enough to compress the gasket.
 - b. hand tight with one-quarter turn with a wrench.
 - c. to a torque of 70 torque-pounds.
 - d. handtight with two complete turns with a wrench.

- 61. (651) If the safety valve is stuck open and cannot be reset by use of the hand-lifting lever, you should
 - a. increase boiler pressure and reset the valve.
 - b. reduce boiler pressure until the valve is not needed.
 - c. close all valves and repair the safety valve.
 - d. take the boiler out of service and repair the valve.

- 62. (651) The safety valve cannot be checked by the ~~hand-lifting~~ gear unless the steam pressure is at least
 - a. 75 percent of normal operating pressure.
 - b. 85 percent of normal operating pressure.
 - c. 95 percent of normal operating pressure.
 - d. 105 percent of normal operating pressure.

- 63. (652) When performing fireside maintenance, how thick should the slag be before it is removed?
 - a. Over 1 inch.
 - b. Over 2 inches.
 - c. Over 3 inches.
 - d. Over 4 inches.

- 64. (653) What type of brick is recommended for emergency patching and building furnace openings?
 - a. Standard firebrick.
 - b. Plastic firebrick.
 - c. Insulating brick.
 - d. Building brick.

- 65. (654) What temperature is required to permit vitrification of plastic firebrick?
 - a. 850° F. to 1000° F.
 - b. 1500° F. to 2000° F.
 - c. 2100° F. to 2500° F.
 - d. 2900° F. to 3000° F.

- 66. (655) You should check the soundness of metal for a steel stack during the
 - a. daily inspection.
 - b. weekly inspection.
 - c. quarterly inspection.
 - d. yearly inspection.

67. (656) What component is installed ahead of the connection to the high-pressure testing gage prior to testing its accuracy?
- a. Air filter.
 - b. Pressure filter.
 - c. Check valve.
 - d. Globe valve.
68. (657) When steam is drawn from a high-pressure distribution line to heat a building, the steam pressure must be
- a. variable.
 - b. raised.
 - c. reduced.
 - d. constant.
69. (658) Corrosion in the condensate return line of a heating system is chiefly caused by
- a. carbon dioxide and oxygen.
 - b. carbon monoxide and oxygen.
 - c. high pH and salts.
 - d. alkalinity and salts.
70. (659) One of the functions of a steam trap is to remove
- a. steam.
 - b. uncondensed steam.
 - c. condensable gases.
 - d. noncondensable gases.
71. (660) Steam traps can be tested for proper operation by
- a. closing the test valve and opening the discharge valve.
 - b. opening the test valve and closing the discharge valve.
 - c. observing continuous steam flow.
 - d. observing continuous condensate flow.
72. (661) The easiest repair and the one that can prevent a valve from being subject to more extensive repair later is
- a. grinding.
 - b. refacing.
 - c. tapping.
 - d. repacking.
73. (662) What type of joints in a steam heating system requires proper alignment and adequate packing within the proper limit of travel?
- a. Ball joints.
 - b. Expansion loops.
 - c. Slip type.
 - d. Bellows type.
74. (663) Insulation of heating lines within a conduit are dried while
- a. conduits are installed.
 - b. heating lines are operating.
 - c. exhaust fans are operating.
 - d. ventilating fans are operating.
75. (664) The insulation most often used to cover warm-air heating ducts and steam and hot water pipes is known as
- a. tube insulation.
 - b. block insulation.
 - c. sheet insulation.
 - d. blanket insulation.
76. (665) A component in the steam system which is the same type as the pressure regulating valve is a pressure
- a. reducing valve.
 - b. relief valve.
 - c. auxiliary valve.
 - d. bypass valve.

77. (666) If a boiler is operated for intermittent short periods of time and left idle, it may be necessary to keep it
- empty.
 - filled with water.
 - pressurized with water.
78. (667) When filling a boiler, the temperature difference between the water and the pressure parts of the boiler should never be greater than
- 20° F.
 - 30° F.
 - 40° F.
 - 50° F.
79. (668) A boiler out of operation should be inspected annually to evaluate
- visual deterioration.
 - visual corrosion.
 - placing in operation.
 - major repairs.
80. (669) When a boiler is permitted to be removed from line for inspection, the boiler, firebox, and settings must be
- thoroughly washed on the outside.
 - cooled after draining.
 - cooled before draining.
 - treated to prevent corrosion.
81. (670) Before performing a hydrostatic test, be sure that the steam stop valves are
- partially open.
 - partially closed.
 - completely open.
 - completely closed.
82. (671) Each major command will prepare a schedule of boilers to be inspected at each CONUS installation and forward it on
- AF Form 288.
 - AF Form 296.
 - AF Form 1222.
 - AF Form 3222.
83. (672) The hydrologic cycle refers to
- underground water.
 - lakes, streams, and oceans.
 - water vapor in the air.
 - the natural circulation of water.
84. (673) Water that contains carbonates and bicarbonates, when heated, releases
- hydrochloric acid.
 - hydrogen sulfate.
 - carbon dioxide.
 - bicarbonate.
85. (674) The main purpose of treating boiler water is to
- prevent formation of sludge.
 - keep corrosive agents in solution.
 - allow solids to be drained off.
 - prevent boiler-scale formations.
86. (675) The external treatment of boiler water is usually avoided if possible because of the
- amount and cost of the additional equipment needed.
 - cost of the chemicals used.
 - controls needed to produce suitable water.
 - need for further treatment.

- 87. (676) An ion-exchange water softener removes hardness from water by the softener giving up
 - a. calcium for chloride.
 - b. magnesium for chloride.
 - c. sodium for calcium.
 - d. magnesium for sodium.

- 88. (677) The hydrogen-zeolite water softening process is used where it is necessary to
 - a. decrease water acidity.
 - b. decrease water alkalinity.
 - c. process large quantities of water.
 - d. remove excessive hardness.

- 89. (678) A dirty and packed zeolite bed in a water softener causes
 - a. low inlet water pressure.
 - b. poor cleaning during backwash.
 - c. flooding of the underdrain system.
 - d. excessive differential pressure.

- 90. (679) The annual replacement of the zeolite in a water softener that has been operated properly should not exceed
 - a. 1 percent.
 - b. 3 percent.
 - c. 10 percent.
 - d. 33 percent.

- 91. (680) The reaction tank on a lime-soda water softener should be opened and cleaned at least once each
 - a. month.
 - b. 6 months.
 - c. year.
 - d. 2 years.

- 92. (681) Hardness in water results from
 - a. circulation through metal pipes and equipment.
 - b. dissolved calcium and magnesium salts.
 - c. exposure to iron and sulfur compounds.
 - d. application of heat and pressure.

- 93. (682) When performing a hardness test on water by the EDTA method, the end point of the test is reached when the water turns
 - a. blue.
 - b. pink.
 - c. yellow.
 - d. clear.

- 94. (683) The water level in a tray-type deaerating heater is controlled by
 - a. the steam pressure in the heater.
 - b. a float-actuated control valve.
 - c. a hand-operated control valve.
 - d. an adjustable metering device.

- 95. (684) To check the oil separator on a deaerator for faulty operation, an examination should be made by
 - a. inspecting the site gage for oil.
 - b. removal of the external inspection plates.
 - c. observing the discharge into an open drain.
 - d. disassembling the separator chamber.



- 96. (685) A low-pressure cast iron boiler with excessive scaling should be cleaned with
 - a. acid.
 - b. caustic soda.
 - c. chlorine.
 - d. sodium chloride.

- 97. (686) What concentration of phosphate should be maintained in the boiler water?
 - a. 0-30 ppm.
 - b. 10-30 ppm.
 - c. 30-60 ppm.
 - d. 20-200 ppm.

- 98. (687) For convenience and safety, sampling connections should be
 - a. brought straight out from the boiler.
 - b. extended down to floor level.
 - c. installed and removed for each sample.
 - d. installed with quick disconnects.

- 99. (688) What is required to make an atmospheric cooled sampling coil?
 - a. 5 feet of 3/8- or 1/2-inch copper tubing.
 - b. 5 feet of 1-inch copper tubing.
 - c. 25 feet of 3/8- or 1/2-inch copper tubing.
 - d. 25 feet of 3/8- or 1/2-inch steel tubing.

- 100. (689) What is the first step in collecting a water sample from a boiler?
 - a. Reduce boiler pressure.
 - b. Blow down the boiler.
 - c. Blow down all sampling lines and connections.
 - d. Adjust the sampling line to reach the bottom of the bottle.

- 101. (690) Other than the base waterplant laboratory, periodic analysis of water from Air Force operated boiler plants should be made by the
 - a. Bureau of Standards.
 - b. Bureau of Mines.
 - c. General Services Administration.
 - d. Department of Defense.

- 102. (691) The label on a boiler sample should have the name of the base
 - a. and date only.
 - b. building number and date only.
 - c. boiler number and who took the sample.
 - d. building number, date, and boiler number.

- 103. (692) Which of the following is a specific irritant?
 - a. Hydrochloric acid.
 - b. Sodium hydroxide.
 - c. Petroleum fuels.
 - d. Potassium hydroxide.

- 104. (693) From where are the test kits obtained for making your boiler water tests?
 - a. Bureau of Mines.
 - b. Bureau of Standards.
 - c. Base waterplant laboratory.
 - d. General Services Administration.

- 105. (694) The purpose of treating boiler water with sodium sulfite is to
 - a. add oxygen to the water.
 - b. remove oxygen from the water.
 - c. remove sulphur from the water.
 - d. neutralize the sodium sulfate.



- 106. (695) The water sample to be tested for sodium sulfite should be cooled to at least
 - a. 40° F.
 - b. 50° F.
 - c. 60° F.
 - d. 70° F.
- 107. (696) Caustic soda is added to the boiler water to neutralize
 - a. iron.
 - b. sulphur.
 - c. sodium sulfate.
 - d. acid materials.
- 108. (697) When making the causticity test on water and causticity is present, the solution will turn
 - a. red.
 - b. pink.
 - c. blue.
 - d. orange.
- 109. (698) To maintain a 30 to 60 parts per million level phosphate in the boiler water, you add
 - a. caustic soda.
 - b. sodium metaphosphate.
 - c. caustic soda and sodium chloride.
 - d. sodium metaphosphate and caustic soda.
- 110. (699) When making a test for phosphate in boiler water, which color indicates that phosphate is present?
 - a. Red.
 - b. Green.
 - c. Black.
 - d. Blue.
- 111. (700) Tannin in boiler water
 - a. acts as an oxygen absorber.
 - b. adds oxygen to the boiler water.
 - c. causes sludge to form as a solid.
 - d. causes a finely divided sludge by adding oxygen to the water.
- 112. (701) Which items are needed to filter a sample for the tannin test?
 - a. Screen and round test tube.
 - b. Screen and square test tube.
 - c. Filter, funnel, and square test tube.
 - d. Filter and round test tube.
- 113. (702) When making the electrical conductivity test, you are testing for
 - a. caustic soda in the boiler water.
 - b. sodium chloride in the boiler water.
 - c. calcium sulfate in the boiler water.
 - d. dissolved solids in the boiler water.
- 114. (703) The instrument for making the electrical conductivity test requires which voltages?
 - a. 6 to 24.
 - b. 24 to 48.
 - c. 105 to 130.
 - d. 208 to 220.
- 115. (704) How can corrosion in the return line from the boiler be partially controlled?
 - a. Calcium phosphate treatment.
 - b. Sodium chloride treatment.
 - c. Acid treatment.
 - d. Amine treatment.



- 116. (705) Morpholine is a neutralizing amine usually used in plants which operate above the minimum pressure of
 - a. 20 psi.
 - b. 30 psi.
 - c. 40 psi.
 - d. 50 psi.
- 117. (706) Which pH reading represents acidity in the condensate return water?
 - a. 6.5.
 - b. 7.0.
 - c. 7.5.
 - d. 8.0.
- 118. (707) Which form is used for the water treatment log?
 - a. AF Form 601B.
 - b. AF Form 1459.
 - c. AF Form 1444.
 - d. AF Form 1447.
- 119. (708) The causticity of boiler water should be limited to a maximum of
 - a. 10 ppm.
 - b. 20 ppm.
 - c. 200 ppm.
 - d. 400 ppm.
- 120. (709) When working with acids, minimum safety protection requires the wearing of
 - a. rubber apron, safety shoes, and goggles.
 - b. rubber gloves, rubber apron, and respirator.
 - c. goggles, rubber gloves, and rubber apron.
 - d. respirator, rubber gloves, and goggles.
- 121. (710) Chemicals in a storage area should be stacked
 - a. only one layer deep.
 - b. not more than the chest height of the person using them.
 - c. not more than 6 feet high.
 - d. to use minimum floor space.
- 122. (711) Sodium metaphosphate should be dissolved in
 - a. cold water.
 - b. hot water.
 - c. a jet of steam.
 - d. water at room temperature.
- 123. (712) Feeding chemicals into the feedwater at a constant rate is particularly desirable when
 - a. decreasing causticity.
 - b. feedwater needs little treatment.
 - c. raising the pH.
 - d. adding quebracho tannin.
- 124. (713) When installing an open chemical feeder tank, one precaution that must always be taken is to insure there is
 - a. no connection made to the hot water supply.
 - b. no direct connection made to the potable water supply.
 - c. enough flow to insure slug feeding of the chemicals.
 - d. adequate air space in the tank for expansion purposes.

